

DESCRIPTION

AMCOM's AM002052S2-0H is a high-power broadband SPDT power switch module. It has 0.8dB typical insertion loss, good isolation and less than 1.5 VSWR from 10 to 2500MHz. This SPDT switch can handle up to 150W CW RF power from 500 to 2500MHz. Switching time is less than 10 microseconds. Switch needs +28V voltage supply and TTL control to switch between ports.



FEATURES

- Broadband from 10 to 2500MHz
- CW Power handling is 52dBm
- Typical 0.8 dB Insertion Loss
- Input & output matched to 50 Ohms

APPLICATIONS

- T/R modules
- Instrumentation
- Lab Measurements
- Modulators

TYPICAL PERFORMANCE * (Bias= 28V / 230mA)

Parameters	Minimum	Typical	Maximum
Frequency		10 – 2500MHz	
Insertion loss		0.8dB	1.25dB
Input Return Loss	10 dB	15dB	
Isolation 10 – 500MHz		> 50dB	
Isolation 500 – 1000MHz		> 40dB	
Isolation 500 – 2000MHz		> 20dB	
Maximum CW power from 200 to 500MHz ** Maximum CW TX power from 500 to 2500MHz		0.3W * Freq. (MHz) 150W	
TX to RX mode Switching Time		< 10μsec.	
+28V Current		200 to 300mA	
TTL Voltage Control Vc (TTL=0 THROW2 ON)		0 to 0.7V	
TTL Voltage Control Vc (TTL=1 THROW1 ON)		2.2 to 3.3V	

*Specifications subject to change without notice

** CW RF Power rated at 0.3dB compression

ABSOLUTE MAXIMUM RATING

Parameters	Symbol	Rating
Supply Voltage (+28V)	+28V	35V
CW RF Power		150W
Ambient Temperature		60°C
Storage Temperature		-40°C to 125°C

SMALL SIGNAL DATA*

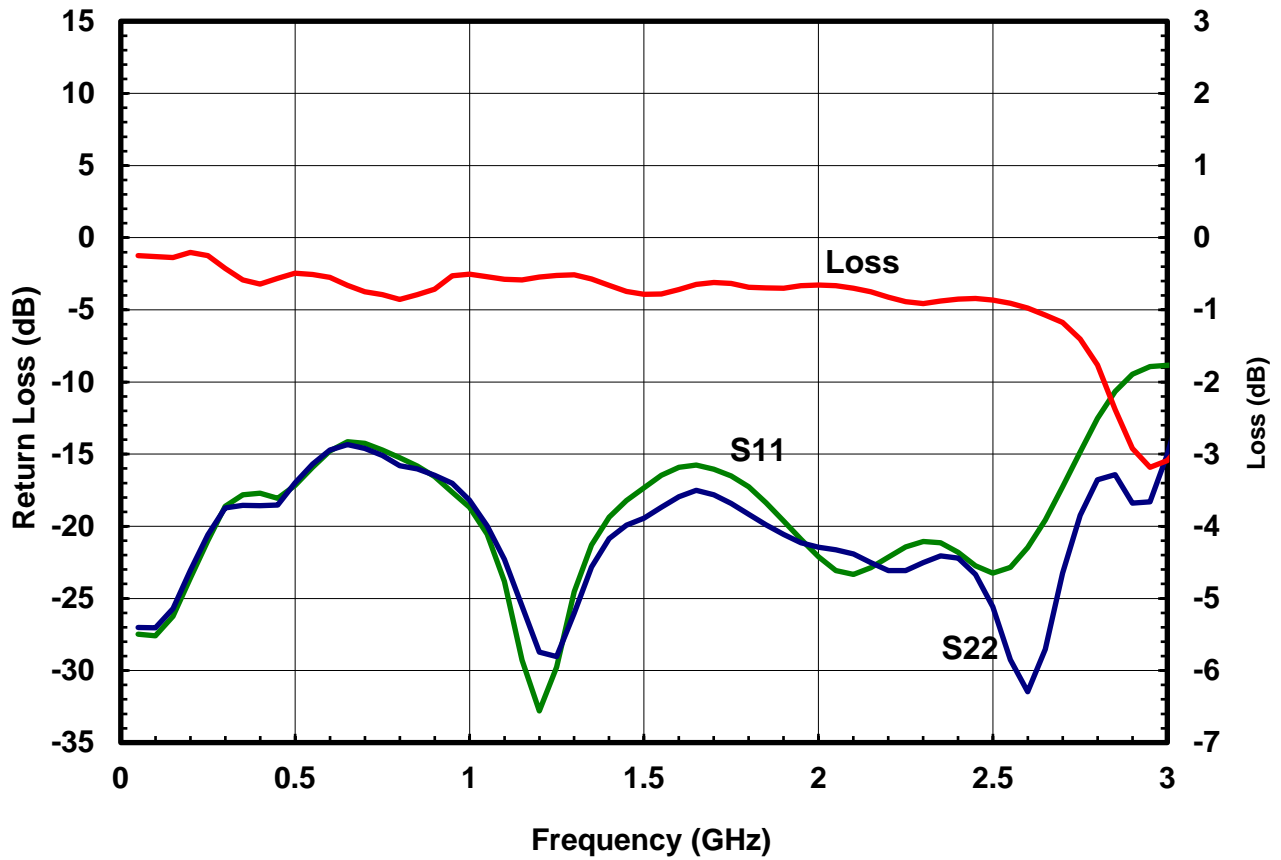
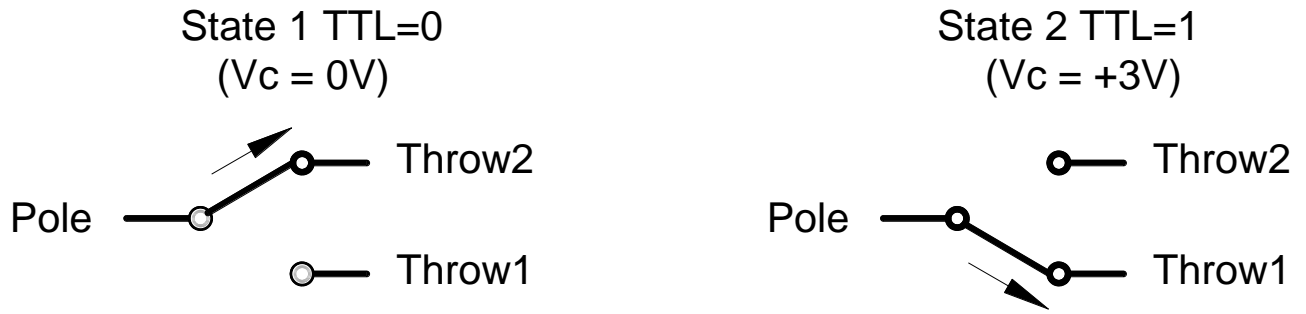

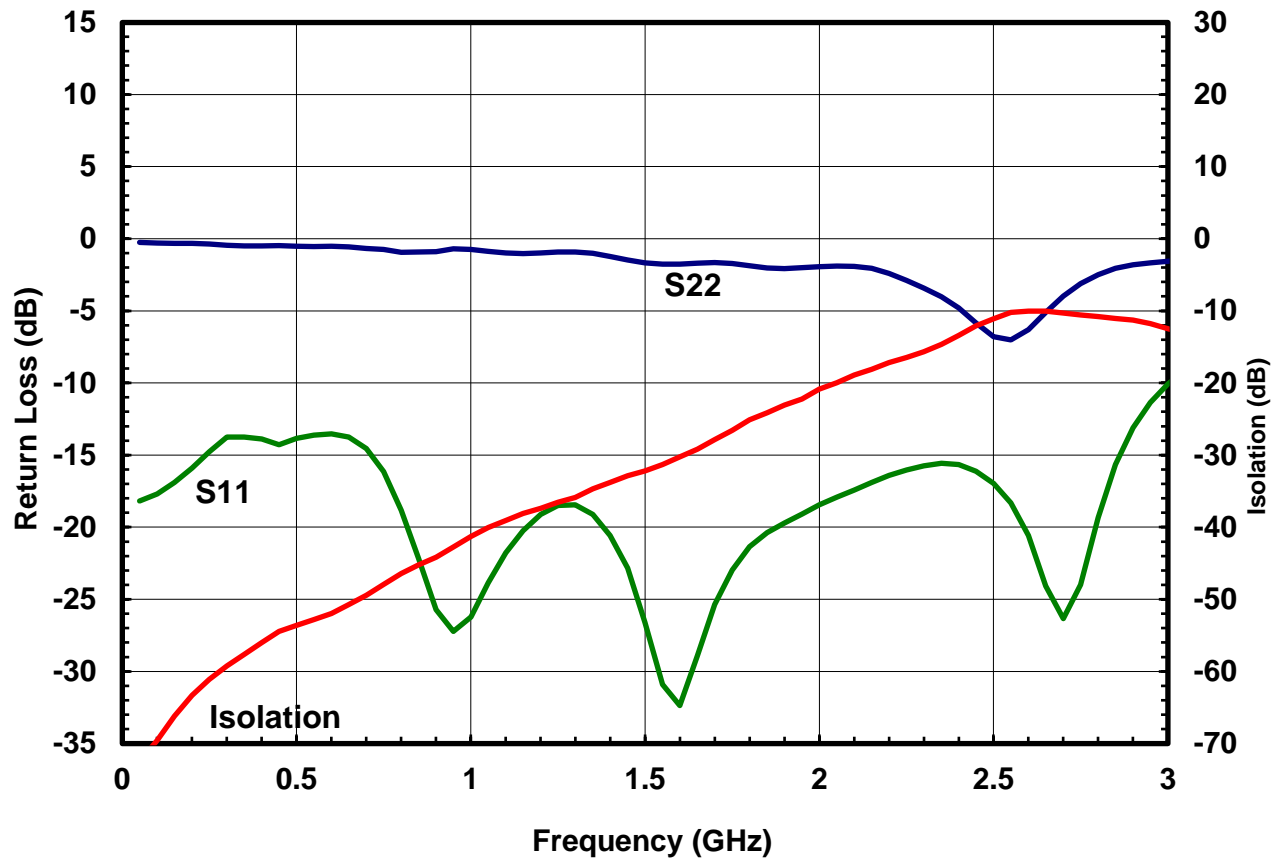

* Small signal S-parameters do not change with voltage supply

POWER **

CW Power at +28V Supply

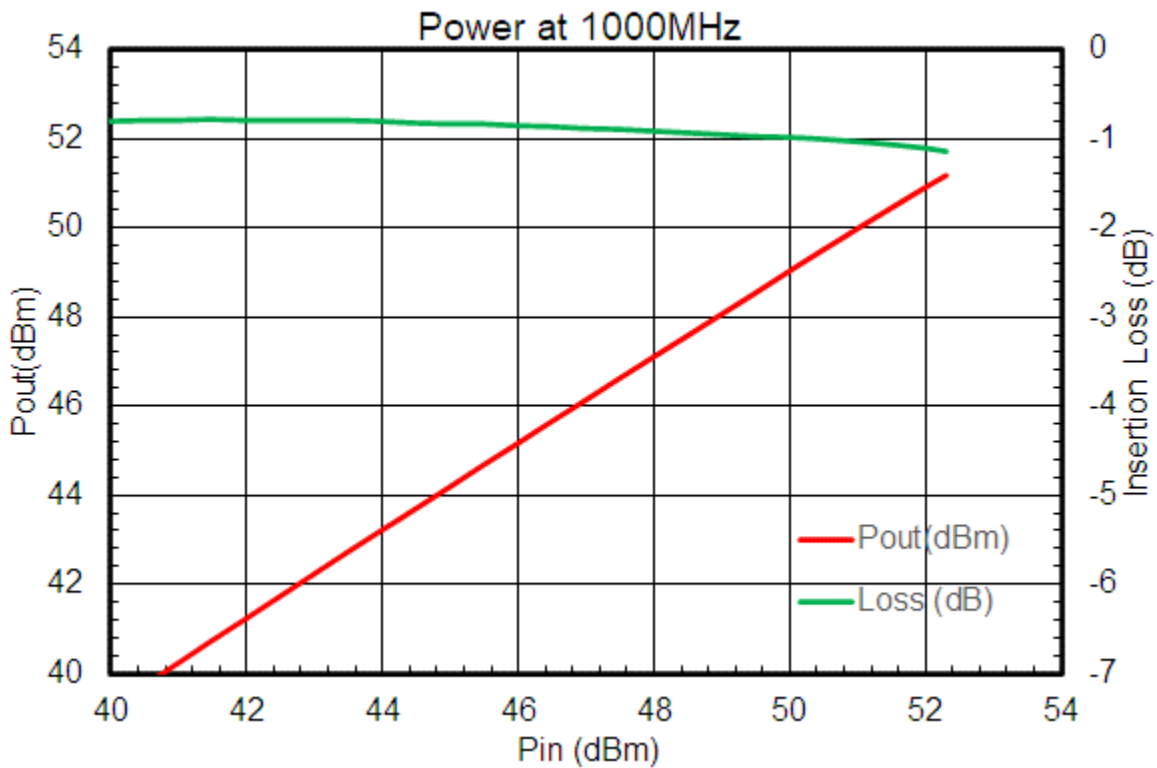
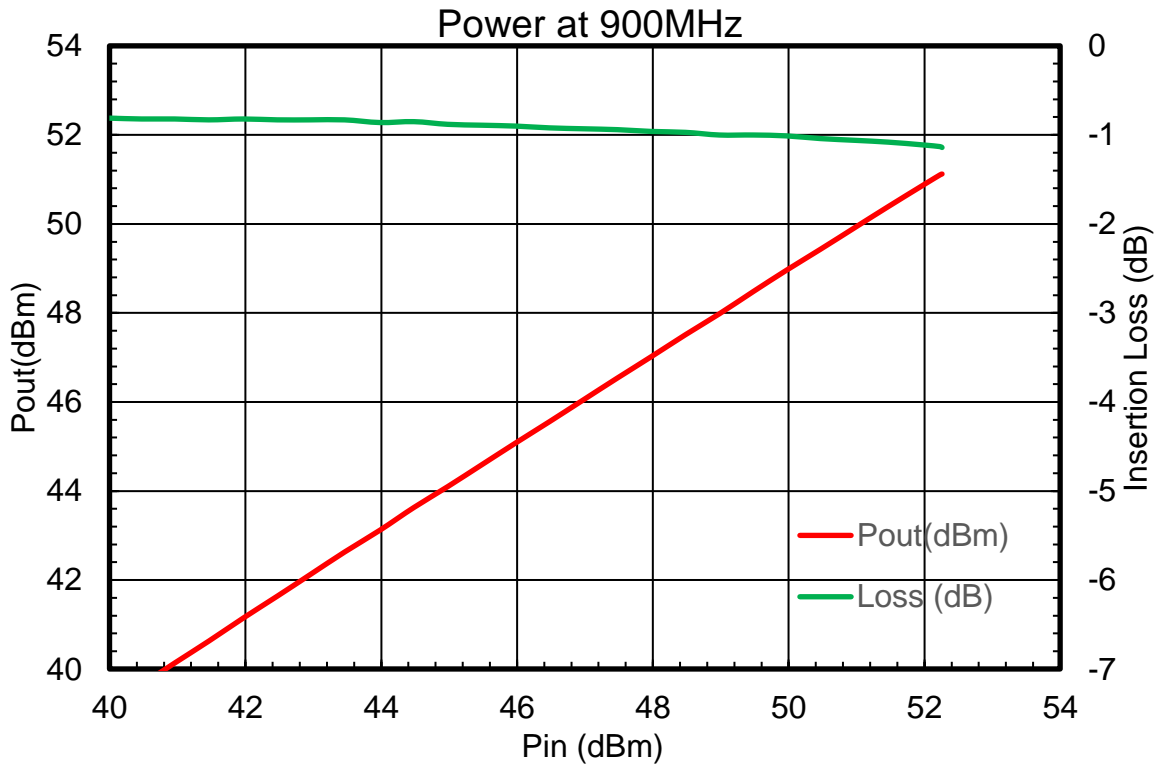

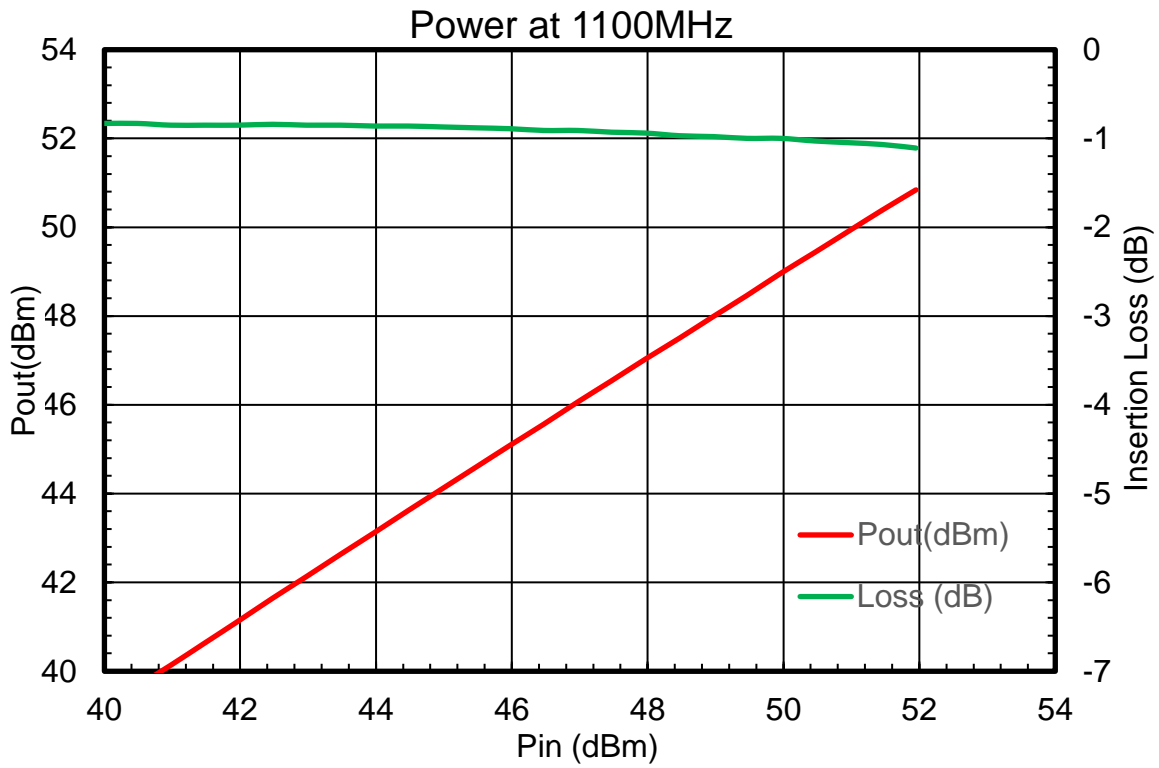

** Power changes with voltage supply. Pulsed RF power higher than CW.

PACKAGE OUTLINE

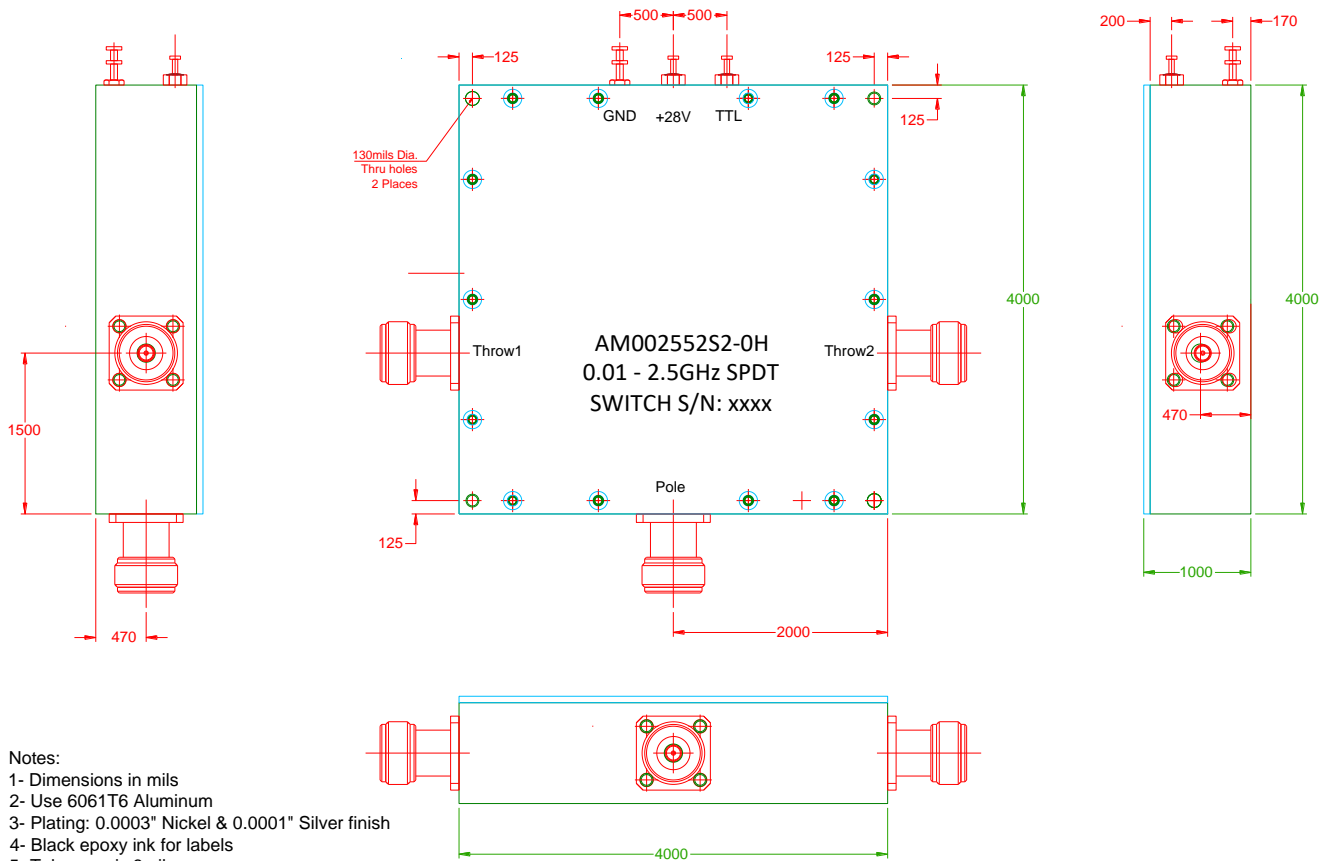

Notes:

- 1- TTL=0 for Pole to Throw1, TTL=1 for Pole to Throw2.
- 2- Maximum RF power is 150W (52dBm) from 500MHz to 2000MHz. Maximum power from 100 to 500MHz is according to the formula $P_{max}=0.3W \times \text{Frequency (in MHz)}$.
- 3- Switch is symmetric.
- 4- All ports have female N-type connectors.