

Concentrated Solar Power | CSP

Solar power around the clock

GREEN ELECTRICITY

GREEN HEAT

GREEN HYDROGEN

Supported by:



Federal Ministry
for Economic Affairs
and Energy

on the basis of a decision
by the German Bundestag



Solar tower (CERRO DOMINADOR)



Parabolic trough (FICHTNER GMBH & CO. KG)



Fresnel collector (FRENELL GMBH)

Imprint

Publisher

German Association for Concentrated Solar Power (DCSP)

Address

Oranienburger Str. 15
10178 Berlin / Germany
Phone: +49 30 232 56 53 0
E-Mail: office@deutsche-csp.com
www.deutsche-csp.com

Editorial

Juliane Hinsch, Dr. Joachim Krüger,
Jürgen Hogrefe

Author

Jürgen Hogrefe / 1Future.international

Layout

Angela Pelzl, www.apema.de

Cover

Noor 2 parabolic trough power plant and
Noor 3 solar tower power plant Ouarzazate/
Morocco (Fichtner GmbH & Co. KG)

Date

Berlin, May 2021

German Association for Concentrated Solar Power (DCSP)

Since 2013, the German Association for Concentrated Solar Power has been committed to the generation and use of electricity, heat and fuels from concentrated solar technologies. Its members cover the entire CSP value chain. This ranges from project development and planning, engineering services, component supply and system integration to the ownership and operation of solar thermal power plants and research facilities. The aim of the association is to bundle the strengths and interests of German market participants and to increase international market opportunities.



German Association for Concentrated Solar Power

Contents

04 – 05	CSP: Solar power around the clock The contribution of concentrating solar thermal (CSP) to the global energy transition
06 – 07	CSP – a multi-talent How solar thermal energy can be used
08 – 09	How concentrating solar thermal works
10 – 11	The thermal storage CSP technology delivers the sun's energy even at night
12 – 13	Hybrid power plants CSP technology brings more photovoltaic and wind power to the grid
14 – 15	Green heat with CSP ... for district heating and for industry
16 – 17	Green hydrogen – a beacon of hope ... by using CSP
18 – 25	The price of solar thermal energy and its true value
26 – 27	CSP can supply 25% of the world's energy The global markets for solar thermal energy
28 – 29	Local value creation Solar thermal power plants promote a local content of work in user countries
30 – 31	Top products made in Germany The performance spectrum of industry and research

CSP: Solar power around the clock

The contribution of concentrating solar thermal (CSP) to the global energy transition

We are facing one of the most significant transformations in industrial history. Supplying a good seven billion people with energy in a way that conserves resources and does not further climate change is currently one of the greatest challenges facing science, politics, business, the financial world and society.

This mega-task has mobilized the scientific-technical and entrepreneurial imagination. With regulation and considerable financial effort, development paths have been worked out that point in the right direction: Energy must be renewable.

However, with the provision of energy from the sun, wind, water, geothermal energy and biogenic materials, we are only at the very beginning globally: the share of renewables in the consumption of primary energy is currently only five percent. The climate targets set in Paris, however, require us to produce our energy in a climate-neutral way worldwide in just under 30 years.

What is still little known is what concentrating solar thermal power generation can contribute to solving the national and global energy and heat transition. Yet CSP energy is a proven solution for decarbonising energy systems: phasing out coal, gas and oil for the transition to green power, green heat and green cooling. It has great potential for the production of green hydrogen and is therefore a beacon of hope for sustainable fuels in industry and transport.

CSP is natural energy. It collects the sun's energy rays and concentrates them to one point - hence the name Concentrated Solar Power. CSP collects heat from the sun, creating high temperatures of up to 1000 °C and beyond.

Concentrated solar thermal power is a mature technology with a global track record of more than three decades. Around six gigawatts of capacity from CSP power plants have

been installed worldwide. It is long past the early stages of development of a solar industry and now delivers energy at competitive prices. CSP is an energy source with enormous potential that is far from being exhausted.

The heat from concentrating solar thermal can

- + produce green electricity via steam turbines and feed it into the grid
- + store solar energy at low cost
- + provide green local and district heating
- + generate green process steam for energy-intensive industry
- + make a significant contribution to the production of green hydrogen

Perhaps the most significant contribution of CSP power plants is their storage capability. Thanks to their ability to store heat in large quantities at low cost, CSP power plants can supply green electricity around the clock. "Clean Power on Demand 24/7" is what the World Bank and the International Energy Agency IRENA called a study in early 2021 that highlights the enormous importance of CSP technology for energy systems.

With their storage facilities, CSP can decisively advance the global energy transition. They deliver green energy even when the sun is not shining, and the wind is not blowing. Thus, the grid, which is a complex energy system, can be stabilised. The danger of power fluctuations and blackouts is minimized.

The heat from the storage facilities of CSP power plants is the link to feed more fluctuating energy from wind turbines and photovoltaics into the grid cost-effectively and without problems. This is how grids become green.

Clean Power
on Demand
24/7

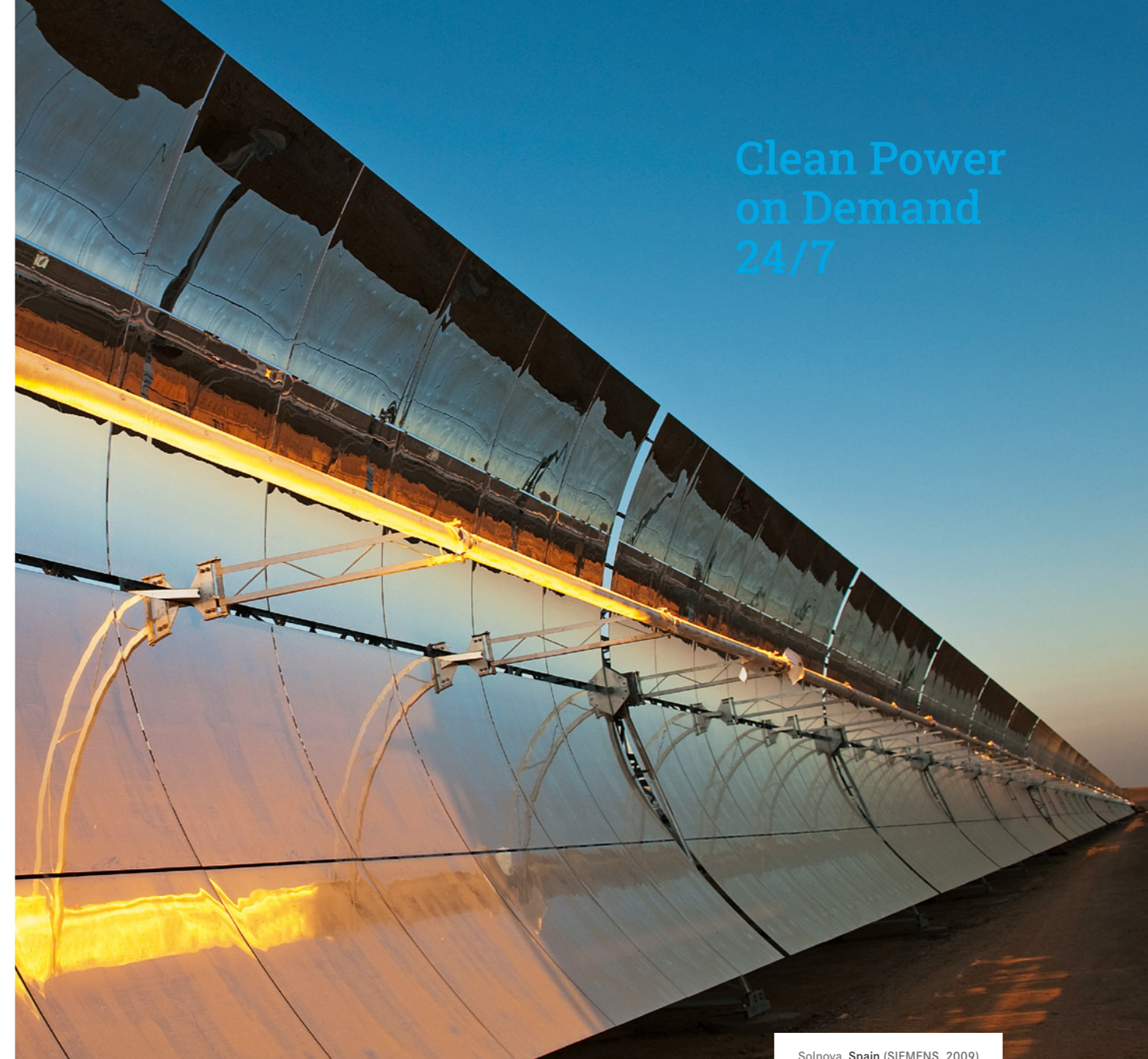

Solnova, Spain (SIEMENS, 2009)

Hybrid power plants that combine the various common renewable energies are on the verge of rapid development. Multi-technology solutions are the key to stable green energy systems. CSP plays a key role in this.

In this presentation we want to shed light on the great potential of CSP technology: Its technology, its possible applications, its marketability and its significance for the climate.

German scientists, companies and banks as well as institutions of the German government have contributed significantly to the fact that German CSP know-how is installed worldwide and occupies a leading position in research as well as in application.

This top position can be maintained and further expanded through increased expansion of CSP plants around the world as well as in Europe and in Germany.

CSP technology is well on its way to proving its full importance for the green energy systems of the future.



CSP – a multi-talent

How solar thermal energy can be used

The primary product of CSP plants is heat, which is obtained by concentrating sunlight. This heat can be used in very different ways.

The most common application is electricity, which is generated in a Concentrating Solar Power plant. A CSP power plant works like a traditional steam power plant: it produces steam to run a turbine that generates electricity via a generator.

In the CSP power plant, however, the traditionally fossil energy sources such as coal, oil or gas are replaced by the energy of the sun. The sun's light energy is concentrated in a mirror system and fed into the steam cycle via heat carriers and converters. This way the **electricity becomes green**.

However, the heat from CSP power plants can also be used directly, for example as **local and district heat** for heating or also for cooling networks. CSP plants can also supply heat at high temperatures as heat or steam, which are suitable for **industrial applications**.

CSP energy can also be used in the energy systems of the future: for the production of **green hydrogen** and its derivatives by supplying low-cost electricity, as well as with steam at high temperatures for high-temperature electrolysis HTEL to separate the hydrogen.



Examples of applications for concentrated solar thermal energy

Electricity



- + Solar power plants from 500 kWe to 1 GW
- + Hybrid power plants with PV and wind
- + For green electricity

Thermal storage



- + From 2 MWh to 1 GWh
- + Different technologies available
- + Re-use of coal-fired power plants

Local and district heating



- + Green heat for local and district heating networks
- + Temperatures from 60 to 160 °C
- + Cooling and air-conditioning of residential and commercial/ industrial areas
- + Seasonal storage

Process heat



- + Temperatures from 90 to 430 °C
- + For industry: Breweries, food industry, chemical and pharmaceutical industry, paper industry
- + Seawater desalination
- + Solar thermal enhanced oil recovery

Hydrogen



- + Cheap green electricity for electrolyzers
- + Contributions to high-temperature electrolysis (HTEL)
- + Process heat for further processing of the hydrogen into products such as ammonia and methanol



30 MW Fresnel solar power plant Puerto Errade 2, Calasparra, Spain (FRENELL GMBH)

How concentrating solar thermal works

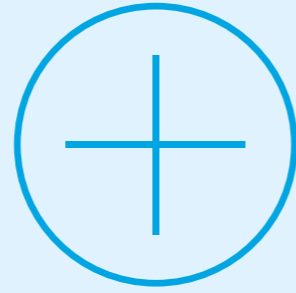

Concentrating solar thermal energy uses the same raw material as photovoltaics (PV) - light from the sun. But in their application and use, these two solar technologies are very different.

While PV converts sunlight directly via a chemical-mineral conversion process into electrical direct current, which is normally fed into the electricity grid via inverters, concentrating solar thermal energy takes a different approach: Here, the light rays of the sun are bundled with the help of mirrors that align themselves with the path of the sun, and the light rays are directed to a specific point or to a focal line. This effectively concentrates the light energy. This concentration generates heat, as in a burning glass. Hence the name: **Concentrated Solar Power (CSP)**.

There are various CSP techniques. But what they all have in common is that they convert sunlight into high temperature. This heat can be used directly or, via heat exchangers, supply a water-steam cycle in which electricity is generated by means of steam turbines.

The technological challenge with the CSP solar field is to achieve the required optical precision and simultaneous robustness against environmental influences such as wind

and temperature fluctuations - at the lowest possible cost. The stronger the concentration of the light rays, the faster higher temperatures can be reached. This increases the efficiency of the process. The higher this is, the less collector area the power plant needs to generate the desired electrical or thermal output.

CSP is High-Tech - and has been tried and tested for decades. CSP power plants function reliably in sunny countries around the globe. Because of the high direct solar irradiation, they already contribute to the production of electricity on a considerable scale here. The performance of CSP plants is demonstrated by their ability to efficiently convert light output into heat. This is why high outputs can be achieved even at low ambient temperatures.

In the meantime, CSP technology has advanced so far that it can also be used to produce heat as well as process heat for industry in temperate climate zones such as Central Europe. Here, demand for process heat at temperature levels of up to 500 °C can easily be met.

In practice, three different techniques are used to concentrate solar radiation: solar towers (1), parabolic troughs (2) and linear Fresnel systems (3).

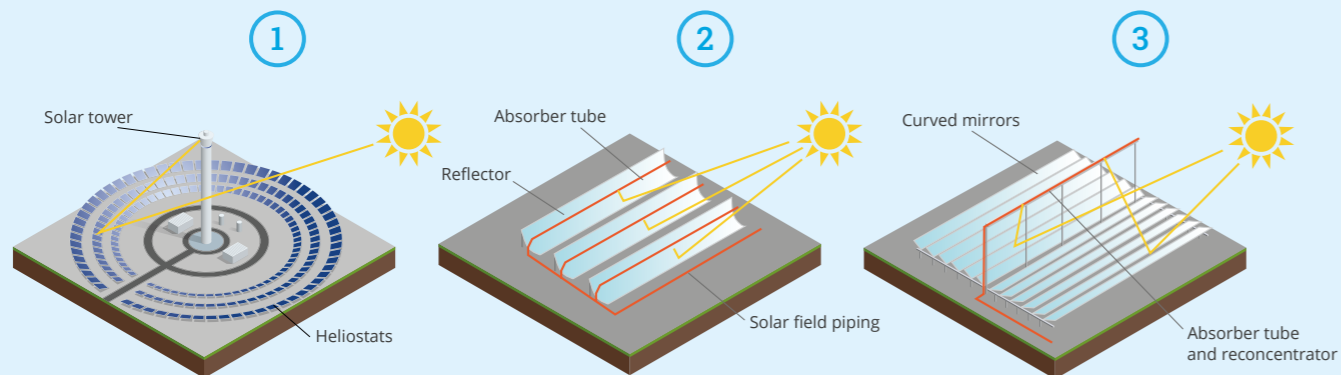

Concentrating solar power technologies
(THE WORLD BANK, IRENA, CLIMATE INVESTMENT FUNDS)

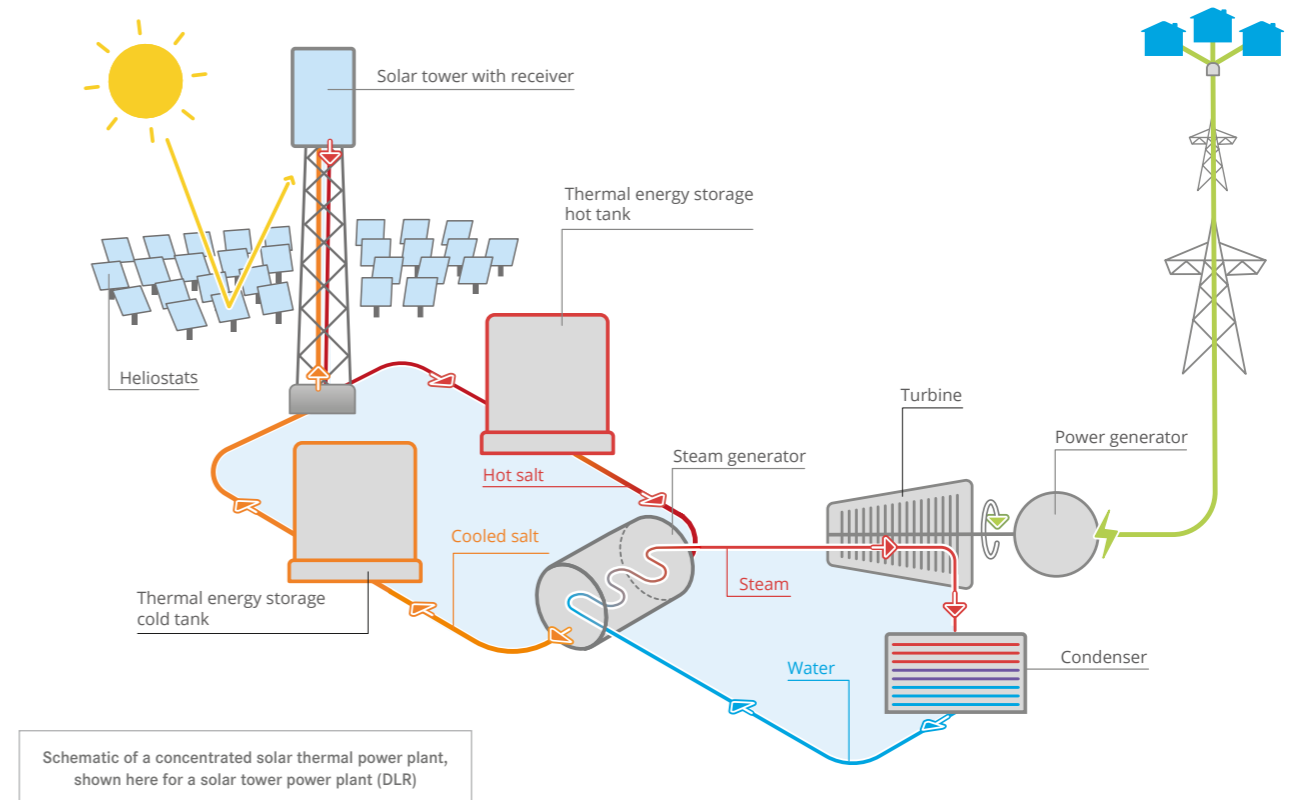

In **solar tower power** plants, mirror surfaces that follow the path of the sun on two axes direct the sunlight onto a central radiation receiver mounted high on a tower. A medium absorbs the heat there. Liquid salt is usually used as the medium. Other media of lesser commercial importance so far are air, water and thermal oils. The medium transports the energy from the solar radiation into the heat storage tank and on to the power plant circuit. The mirror surfaces, also called heliostats, are up to 200 square metres in size. In commercial power plants, several thousand of them are aligned in a semicircle or circle with the solar tower. Their strong radiation concentration generates surface temperatures at the receiver that heat the heat transfer medium to around 600 °C.

Parabolic trough power. To date, parabolic trough power plants have been the most frequently realized commercially. Parabolic troughs, also known as collectors, are guided on an axis by hydraulic drives to follow the path of the sun. They focus the light rays at the focal point of the trough onto an absorber tube that runs lengthwise through the trough at a distance of half the radius of the mirror. The energy of all the incident light rays is combined in this focal line, effectively concentrating the light energy. In this absorber tube, a special thermal oil or a fluid made of other material absorbs the heat. A pump system directs the highly heated fluids into the heat exchanger, which is connected to a water-steam circuit.

The absorber tubes are the heart of the collectors: an optically selective coating on the tube absorbs visible light and at the same time inhibits the radiation of heat. The absorber tube is surrounded by a slightly larger glass tube, and similar to a thermos flask, there is a vacuum between the two tubes. This considerably reduces heat loss through radiation.

The collectors are up to seven meters wide and up to 200 meters long. The thermal oils commercially used today in the receivers allow an operating temperature of up to 430 °C. New media are currently being researched and tested that can absorb higher temperatures without causing damage, e.g. liquid salts with an operating temperature of up to 600 °C.

Fresnel collectors function similarly to parabolic troughs. However, the concentrating mirror is divided into elongated, individual facets, which are also oriented according to the position of the sun. They are arranged horizontally at some distance above the ground. The absorber tube is mounted above the mirrors. The frames that hold them are installed in a fixed position. This type of construction is very robust and can therefore withstand high wind loads; in addition, small designs are possible, which also allows installation on flat roofs. The special collector geometry entails a lower optical efficiency, but this is compensated for by lower collector costs.

The thermal storage



Theramli storage Andasol 3, Spain, owner Marquesado Solar (CSP SERVICES GMBH)

CSP technology delivers the sun's energy even at night

An important component of solar thermal power plants is the **integrated thermal storage**. CSP is capable of first converting energy from solar radiation into thermal energy. Depending on the heat transfer fluid (HTF) used, this heat can either be stored or used directly to generate heat or electricity. Thermal energy storage thus makes it possible to use solar radiation 24 hours a day. CSP allows the sun to shine at night, so to speak. The heat of the sun makes it possible.

Solar thermal power plants rely on the storage of the intermediate product, heat, rather than the end product, electricity. While transporting heat over longer distances and longer periods of time is more expensive and more complicated than transporting electricity, the opposite is true for storing heat.

When using large storage facilities that can deliver a fixed output over a long period of time, there is better **economic efficiency** for heat storage. Thus, storing heat with CSP technology in sunny areas already enables an electricity price similar to conventional power plants or below.

In their 2021 study, IRENA and the World Bank stated that electricity generation with concentrating solar thermal plants and heat storage with a capacity of more than four (full-load) hours is cheaper than electricity generation from PV with the storage of electricity in battery systems. Depending on the location with higher solar irradiation, this advantage of CSP can also be achieved with smaller storage sizes, i.e. less than four (full-load) hours. It is to be expected that battery storage will approach the cost advantage of CSP storage in the long term due to cost reductions. Therefore, the advantage of thermal storage will shift towards larger storage units over time.

The thermal storage units based on **liquid salt** are containers (tanks) up to 40 meters in diameter and 15 meters high. They are filled with a mixture of potassium nitrate and sodium nitrate, which becomes liquid at 250 °C and above. The tanks with the molten salts are used to absorb the heat from the solar collectors and receivers and release it at a later time.

Today, liquid salt storage tanks (also called molten salts) are commonly used in commercial operations. They consist of two tanks, each with a hot and a cold temperature level. In the so-called loading process, the liquid salt is pumped out of the colder tank at about 290 - 300 °C and then heated either directly in the receiver by the concentrated solar radiation or indirectly via another heat exchanger. The heat is then transferred to the hot tank. In the unloading process or heat extraction, liquid salt is pumped out of the hot tank and transfers the heat directly or indirectly to a **steam generation process** by means of a heat exchanger, where it is cooled again and then transferred to the cold tank. During loading and unloading processes, the filling levels of the two tanks thus shift as in corresponding vessels. During technical operation, it must always be ensured that the temperature of the salt does not fall below a minimum temperature so that the mixture does not crystallize again. Depending on the salt used, working temperatures of up to 565 °C are possible.

To generate electricity, the steam generator is supplied with heat energy, which comes either directly from the solar receiver or from the storage tank. The **steam** generated with the heat then drives a classic steam turbine process. The steam turbines used in solar power plants can be operated very flexibly and can thus ideally follow demand.

The plants in commercial operation already have storage capacities of between six and 15 full-load hours. This means that they can be operated around the clock or specifically at times of peak demand. **Thermal storage** allows energy quantities to be shifted over one or, if necessary, several days. Since electricity generation can be flexibly adjusted to demand, solar thermal power plants belong to the group of **dispatchable power plants**. They are base-load capable because they are able to reliably feed a predictable amount of electricity into an energy system such as the grids over a long period of time.

Although CSP storage technology has long been proven and is already reliable, **leaps in development** can still be expected through research and increased deployment and mass production. These will lead to a further reduction in costs.



Hybrid power plants

CSP technology brings more photovoltaic and wind power to the grid

The indirect way of first converting solar radiation into thermal energy and only then into electrical energy seems laborious compared to PV solar cells, which immediately convert sunlight into electricity. In fact, however, this is one of the **advantages of solar thermal power plants and an enormous value for future energy systems without fossil fuels**: Heat is easier and cheaper to store than electricity. With their low-cost heat storage integrated directly into the power plant, CSP plants can supply green electricity even when photovoltaics and wind power do not, for example at night and when there is no wind.

In the future, the complementarity of the different forms of renewable energy production will play a greater role in the European and global energy transition as a whole. It is precisely in the coupling of different renewable energies that their advantage will become all the more apparent - both in terms of the economic and the ecological balance.

Recently, the World Bank and the International Energy Agency IRENA stated that solar thermal power plants coupled with PV or wind power plants will play an increasingly important role in the global expansion of renewable energies. This applies in particular to electricity production in sun-rich countries.

There are a number of reasons in favour of coupling in so-called hybrid plants.

If CSP power plants are combined with photovoltaic fields, the specific **electricity production costs** (LCOE) for the CSP plant can be reduced considerably. The CSP power plant can operate the same turbine, but its solar field can be smaller and various ancillary systems can be dimensioned smaller, as the PV modules can serve the peak loads in the grid more cost-effectively. At the same time, the surplus electricity from PV modules can be used to temper the salt storage tanks.

PV and CSP can also share the general utilities and infrastructure that a solar farm needs: Line connection, telecommunication, administration, security, administration buildings and maintenance of technical equipment. The same applies in principle to wind farms. This significantly reduces investment costs.

Renewable energy producers such as PV or wind plants currently shift the task of stabilizing the grid when they cannot supply electricity (for example in partial load or in the so-called dark doldrums) mostly to other power plants that are predominantly fossil-fuelled. CSP power plants can also cover this grid service during such times. In this way, fossil power plants can be replaced by CSP and greenhouse gases can be reduced cost-effectively or avoided altogether.

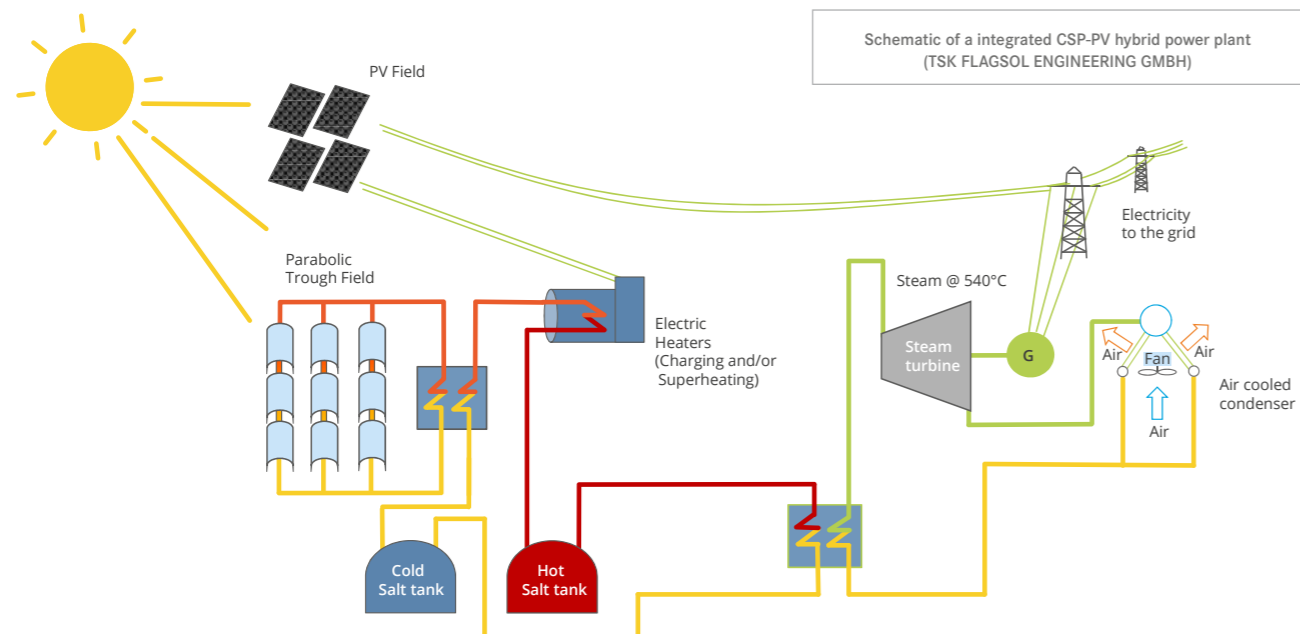

CSP-PV hybrid power plant (co-located) Cerro Dominador, María Elena/Chile (CERRO DOMINADOR)

The storage of energy quantities and the associated controllability of CSP plants enables the balancing of fluctuating energies and ensures the necessary voltage in the grid. This ability to stabilize the grid is a central characteristic of solar thermal power plants. It is the value of this type of plant for a future system for the production of green electricity.

In addition, there is the climate policy significance of CSP technology for the European and German hydrogen strategy and for the provision of heat for district heating. It is dealt with separately here on pages 14-15.

THE FUTURE OF COMBINED-CYCLE SYSTEMS HAS ALREADY BEGUN

A large capacity hybrid power plant will soon be built in Morocco. The NOOR Midelt power plant in Morocco will combine CSP and PV for a total installed capacity of 800 MW. The DEWA „Mohammed bin Rashid Al Makhtoum Solar Park Phase IV“ project in Dubai, which is scheduled to come on stream in 2022, combines 700 MW of CSP with 250 MW of PV. The CSP technologies used are a solar tower with 100 MW capacity and a thermal storage of 15 hours capacity as well as three CSP parabolic trough power plants. The latter have an output of 200 MW each and storage with a capacity of 12.5 hours each. Technically, this is not precisely a hybrid power plant, but an addition of different technologies. The interesting thing about it, however, is that here the CSP power plants provide for the peak load in the grid, which is in the evening hours - after sunset, when PV cannot supply.

With 950 MW, the DEWA IV solar complex is not only the largest renewable energy power plant project in the world with an investment of 4.2 billion US dollars. It is part of a large solar complex totaling five Gigawatt. It is also the lowest electricity price ever quoted for a CSP power plant: The contract for the electricity provides for a purchase price of 0.073 US dollars per kWh. This applies for a term of 35 years.

This considerable reduction in the price of CSP electricity in recent years has been largely due to the rapid drop in prime costs for CSP power plants (chapter prices pages 18-25).

Green heat with CSP



... for district heating and for industry

The conversion to green, that means renewably produced heat is one of the sectors of energy policy that is still least penetrated and least planned. Yet the need for action is enormous.

In Germany, an industrialized country, industry accounts for 29 percent of final energy consumption. The vast majority of this, almost 75 percent, is required as so-called process heat in the higher temperature ranges. In fact, this means that the energy consumption for the provision of process heat in industry is roughly equivalent to the entire German electricity consumption.

The German government recently has proclaimed the goal of increasing the share of renewable energies in final energy consumption for heat (space, cooling and process heat as well as hot water) to 30 percent by 2030.

On a global scale, industrial heat energy demand even exceeded total global electricity consumption by 18 percent.

By far the largest share of heat is currently still generated with fossil fuels. With its technological possibilities, concentrating solar thermal (CSP) can make a good contribution to the success of the German, European and global heat transition.

Concentrating collector systems such as parabolic troughs and Fresnel mirrors produce – depending on their design and mode of operation – heat between 60 and about 500 °C operating temperature. Within this range, CSP plants can provide green process heat as well as local and district heating even in Germany.

Local and district heating

German district heating network operators provided around 161 TWh of heat in 2017, almost exclusively from fossil generation. CSP solar collectors – installed and operated in this country – can make a significant contribution to meeting this demand for **hot water and heat for buildings** in the future.

The major advantage of CSP is the same for heat production as for electricity production: CSP solar collectors collect the sun's thermal radiation and concentrate it to high temperatures that allow **effective storage**. Storage leads to a high degree of coverage and a more seasonally balanced supply of heat.

Contrary to widespread belief, parabolic trough and Fresnel collectors also function technically well in **less sunny** regions and are also economically viable. This is true even at comparatively low operating temperatures from 60 °C. In the meantime, various scientific studies have shown the potential of parabolic trough collectors for heat in Germany. The positive results have meanwhile found their way into the VDI Guideline 3988 "Solar Thermal Process Heat", among others. VDI guidelines represent the state of the art and set the guiding and practice-oriented standards.

In Germany, almost exclusively a few stationary flatbed or vacuum tube systems are in operation or planned for the production of solar heat in industrial processes. Experience shows that the yield of such stationary collectors is somewhat higher than that of CSP plants at low operating temperatures. However, as operating temperatures rise, the thermal losses of such equipment have a greater impact. These losses are significantly lower with the tracking, concentrating CSP collectors.

CSP collectors can already achieve heat production costs comparable to those of stationary collectors if the temperatures are 80 °C or above and a solar field the size of several thousand square meters is used. CSP collectors with lower temperature requirements than 80 °C are already more economically viable when storage facilities are integrated.

The **economic viability** of CSP heating systems has been shown to be even further north of Germany. In Denmark, a country with large municipal heating networks, 1.6 million square meters of collector area have already been built for local heating sup-

ply, often in combination with seasonal heat storage. Almost 50,000 square meters have been built in more recent projects with CSP collectors.

Here it has been found that parabolic trough collectors deliver higher annual heat yields than flat-plate collectors with the same collector area from an operating temperature of 50-80 °C. At similar investment costs, concentrating collectors show comparable or – at higher temperatures – even significantly better economic efficiency. In Germany, the use of parabolic troughs for district heating support is currently being tested by municipal utilities. The plants will each have between 10,000 and 50,000 square meters of mirror surface and will be able to provide the base load in summer from solar energy.

Unlike electricity generation, the production of heat is locally bound. It cannot be transported economically over long distances. The use of biomass is the only thermal alternative on a larger scale. However, biomass requires more than ten times as much area to generate heat. Nevertheless, at suitable locations, solar thermal and biomass can be synergistically coupled because biomass can feed heat into grids in a predictable way.

Concentrating solar thermal has the advantage over flatbed collectors that it can be operated on a greened area. Plants can exist permanently under the CSP collectors and thus serve **nature conservation**; they also provide space for **biodiversity**. In addition, when converting to CSP plants, existing heating networks can continue to be used and the **building services**, which are designed for higher temperatures, do not have to be completely replaced. Both of these factors together significantly reduce the costs of converting to green heat.

Thermal collectors are long-lasting; their service life is estimated at 30 years or more.

The results of the studies for Germany and the operation in Denmark are largely transferable to the whole of Central Europe. For example, a German company in Belgium uses its

parabolic mirrors to produce heat for industrial plants in the port of Antwerp and Oostende. The solar-produced steam is used to temper the premises of a storage and handling company for chemical products. The climatic conditions for CSP plants are naturally even more favourable in southern Europe than in Central Europe.

Process heat for industry

Concentrating collector systems are suitable for generating process heat up to an operating temperature of 400 °C and beyond, depending on the design. This means that CSP heat can be used in wide areas of industry, in the food, textile and automotive sectors for example.

Four **energy-intensive industries** in particular use high-temperature heat in the range above 400 °C: iron and steel, aluminum, chemicals and petrochemicals, lime and cement. Solar tower systems generate temperatures of over 1000 °C and can introduce the heat required for this into the respective process – either directly through concentrated radiation or via suitable heat transfer media.

Technologies for applications in these industries are still in the early stages of development. But the industrial application phase has begun.

In Cyprus, for example, a company in the food industry uses steam from solar collectors made by a German manufacturer at temperatures of up to 425 °C to pasteurize fruit juices, among other things. The power plant developed in Cologne reduces the Cypriot company's heavy oil consumption by around 20 percent. The atmosphere is thus spared 150 tons of the greenhouse gas carbon dioxide year after year. The operation of the plant is fully automated; the maintenance costs are extremely low, the maintenance effort is limited to mirror cleaning. All components of the CSP power plant are expected to provide full output for more than 25 years.

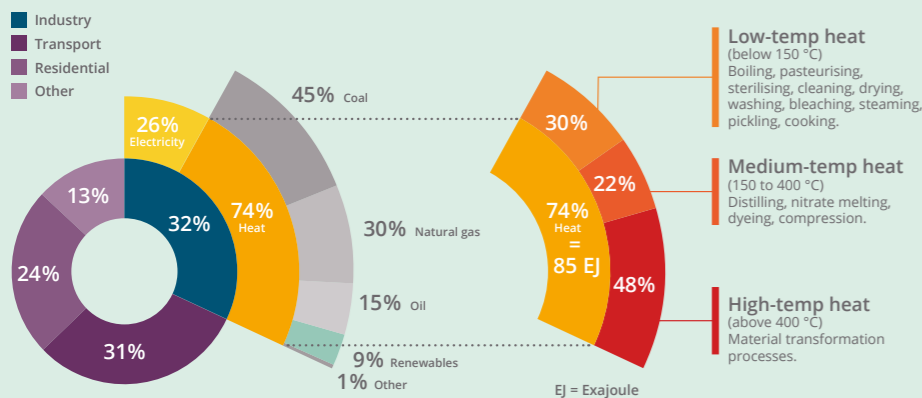

Total final energy consumption 2014 (EPP 2017)



Process heat for the chemical industry in Oostende, Belgium (SOLARLITE CSP TECHNOLOGY GMBH)



Process heat in the food industry, Limassol, Cyprus (PROTARGET AG)

Green hydrogen

– a beacon of hope



... by using CSP

The fundamental transformation of the energy supply requires more than just the switch to electrification, which is made possible in a CO₂-neutral way. We need alternative energy sources that are used sustainably. Here, hydrogen (H₂) is considered a key element.

Due to its high energy content and clean combustion, H₂ can not only function as a fuel in future energy systems, but even as a central energy vector, as an energy carrier, as a storage medium and as a reactant for the chemical industry as well as a feedstock for liquid fuels. H₂ only makes sense with regard to climate policy goals if it can be produced emission-free - at least in the medium term.

Large amounts of energy are needed to produce hydrogen. Germany does not have enough land to ensure the production of green H₂ in its own country. It would take about four to six times as much PV and wind space compared to today to achieve an 85 percent emissions reduction. Germany will have to rely on imports of green hydrogen.

H₂ is still two to four times more expensive than the fossil option. To make hydrogen a significant factor in the energy and heat transition, renewable electricity must be available for its production at the lowest possible cost. The conversion technology and structure must be as cheap as possible. Technically, the conversion efficiencies should be as high as possible and the plants for electricity generation and electrolysis should be utilized around the clock.

These conditions suggest that concentrating solar thermal energy can make a very significant contribution here.

In combination with PV, solar thermal power plants offer excellent opportunities to combine low electricity generation costs with very **high full load hours**. At sunny locations such as in the Middle East, generation costs with CSP in combination with PV are well below 3 €/kg at 7000 full load hours of operation.

PV supplies the electricity during the sunshine hours and simultaneously loads the **heat storage** during the day with the solar thermal system. When the sun is not shining, it is used to provide electricity and, if necessary, heat for **electrolysis**. With such constant utilization of an electrolyser, high conversion efficiencies are also possible. In addition, the infrastructure required for transport – such as pipelines – will be cheaper to operate if the two solar technologies of energy production are combined with each other in hybrid power plants.

Solar-thermal electricity as well as heat from CSP plants can also make a contribution to the electrolysis process itself. Solar thermal energy is particularly suitable for **high-temperature electrolysis** (HTEL), which at high operating temperatures of 700 °C to 1000 °C can achieve significantly higher efficiency in terms of the electricity used: This is because about 20 percent of the energy can be fed into the electrolysis process as high-temperature heat. This is a double benefit of solar thermal energy that will be of great significance.



Chemical plant with solar power plants, photomontage (DLR)

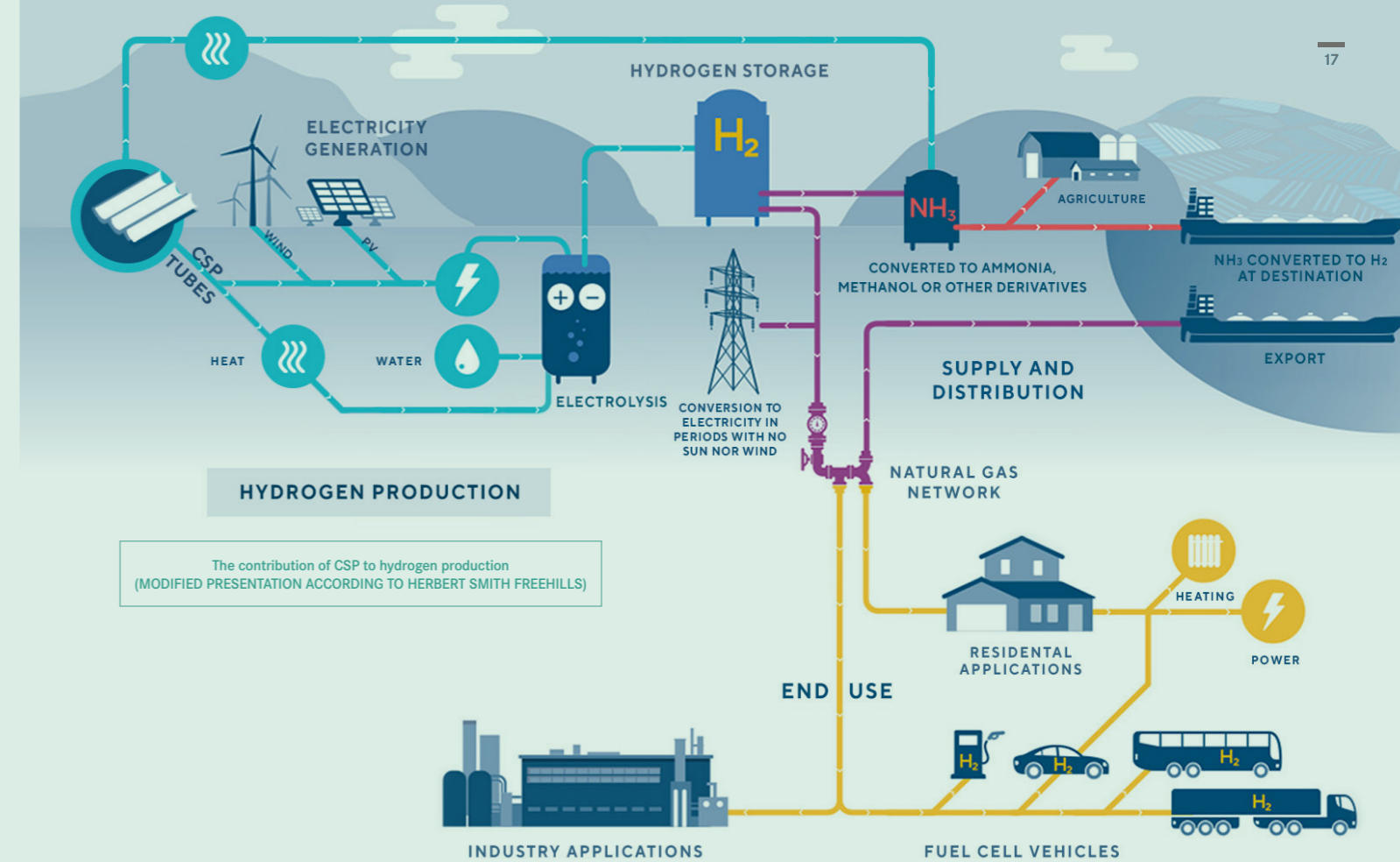

HTEL is only at the beginning of its industrial development; so far only a few pilot plants are in operation. However, it is expected that the investment costs for HTEL plants will be significantly lower than those of the alkaline electrolysis plants (AEL) commonly used today, which have some technological disadvantages anyway. In partial-load operation, for example, the achievable gas purity decreases, and degradation problems occur. Wear and repair costs are the result. In addition, the AEL has so far required a relatively long cold start time of about 50 minutes. This makes it relatively unsuitable renewable energy which have a fluctuating feed-in such as wind or PV.

Hydrogen production costs can be further reduced if HTEL technology is coupled with other systems such as PEM analysis. PEM (proton exchange membrane electrolysis) is a fairly new technology that is particularly suitable for fluctuating renewable electricity. However, it has somewhat lower efficiencies than proven systems, and it also requires the rare metal iridium for its electrodes.

CSP technology can provide high-temperature heat between 200 °C and 800 °C, which is produced cheaply in CSP plants. Coupling reduces operating costs and increases the amount of hydrogen produced.

When the **hydrogen is further processed** into products such as ammonia and methanol (to facilitate storage and transport logistics), the use of concentrating solar thermal energy to provide process heat can also help to reduce costs.

However, all green technologies – in electricity generation as well as in electrolysis – are characterized by the fact that they compete in pricing with the comparatively low costs of fossil energy sources. **Transport and logistics costs** have to be factored in. Only when large quantities of hydrogen are purchased will transport pay off.

Also because of their geographical proximity and correspondingly favourable transport costs, the countries of the Middle East are an important option as a location for the production of green hydrogen - as are the countries of southern Europe, especially Spain and Italy.

The German government has announced its intention to become a technology leader in hydrogen technologies at the international level. German companies are already well positioned internationally in this sector. With its significant contribution to both green electricity and green heat production in international markets, CSP technology is making important contributions to realizing this ambition.



The price of solar thermal energy ... and its true value

Just a few years ago, renewable energies were considerably more expensive than energy produced using fossil fuels such as gas, coal and oil. That is why governments around the world have taken various supportive measures to bring renewable energies into energy systems and markets. In the meantime, the situation has changed in many places. Renewables are often the better choice in many countries, not only because of their importance for the climate, but also from an economic point of view. The trend is clear: 56 percent of all

large power plants based on renewables produce electricity more cheaply than would have been possible with the latest coal-based technology.

In the case of wind and PV, this trend reversal occurred some time ago. CSP technology has recently caught up considerably. This applies to prices for electricity production as well as for the production of heat for direct use in district heating and in industry for process heat.

Electricity

The International Energy Agency IRENA had already noted in a 2020 study that electricity from CSP plants had fallen considerably over the past ten years. In their most recent survey, IRENA and the World Bank came to the conclusion that the prices of CSP power plants per kilowatt hour (kWh) produced in sunny regions are now roughly in the range of conventional power plants.

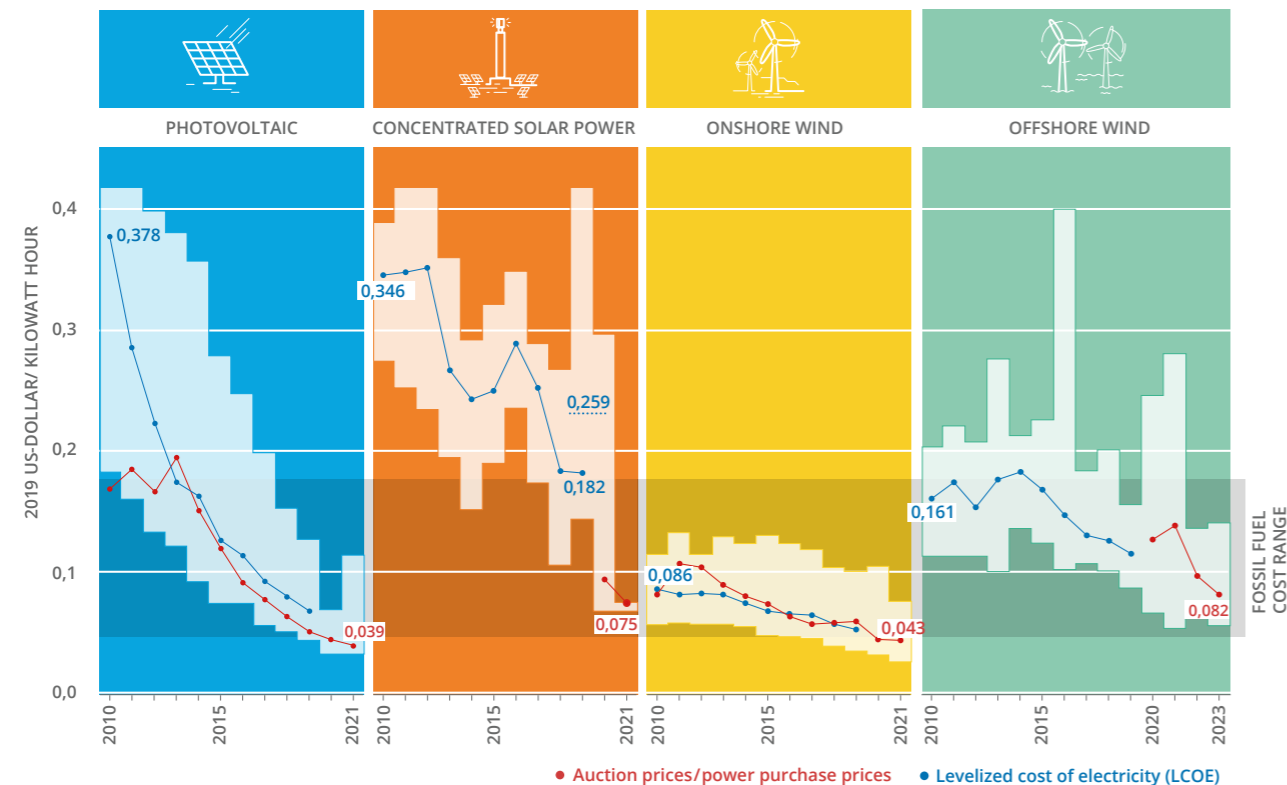

Cost development of renewable energy generation since 2010. The grey shaded area shows the range of costs of fossil energy generation (IRENA 2020)

The International Energy Agency IRENA had already noted in a 2020 study that electricity from CSP plants had fallen considerably over the past ten years. In their most recent survey, IRENA and the World Bank came to the conclusion that the prices of CSP power plants per kilowatt hour (kWh) produced in sunny regions are now roughly in the range of conventional power plants.

The decrease in prices occurred at an astonishing pace. Whereas a kWh in a Spanish solar power plant was still paid US\$ 0.40 in 2012 under a feed-in tariff, the 950 MW CSP/PV power plant DEWA in Dubai will soon supply electricity for US\$ 0.073 per kWh. It is expected that prices will continue to fall rapidly.

This is partly because as CSP plants ramp up, the usual **scaling effect** occurs, which was also seen in PV when installed capacity worldwide increased many times over: from 41 GW in 2010 to 580 GW in 2019. During this period, the cost of PV generation has fallen to about one tenth of the price. With increased construction of plants, a similar scale effect will also be observed for CSP.

Integration von CSP-Kraftwerken ermöglicht eine zuverlässige Energieversorgung ausschließlich auf erneuerbarer Grundlage zu wettbewerbsfähigen Preisen

At the same time, German and European research institutions are working hard on innovations that will also lead to cost reductions. Such potentials through innovation, which can lead to rapid cost reductions, are no longer expected for PV because the technology is considered mature.

However, the way in which the costs for solar power are calculated must be looked at more closely. This is because there are calculation methods that determine the production costs of electricity, but do not really capture the value of the energy provided.

It makes sense - also for reasons of cost comparison - to have a common basis for calculating the price of electricity. The usual benchmark is the calculated **Levelized Cost of Energy (LCOE)** per kilowatt hour. However, the LCOE are not sufficient for the real evaluation of the electricity produced in the energy system. One reason for this is that it does not include the costs over the entire lifetime of a plant, which must always include operating and wear costs.

Above all, however, the LCOE is not very useful because it does not take into account that solar thermal power plants provide dispatchable renewable electricity due to their integrated thermal storage and thus offer an **added value** that PV and wind, for example, do not have. Fluctuating electricity fed into the system requires a reserve of electricity generation capacity (back-up capacity), which would have to be included in the production costs. It is precisely this capacity - the stabilization of the grids or energy systems - that solar thermal technology provides - and it does so with green energy. In this respect, the price of the kilowatt hour differs from the value of the kilowatt hour.

An interesting and helpful cost comparison can be made by comparing the **prime costs** of PV and wind plants with battery storage with those of CSP power plants with integrated thermal storage. The calculation is not simple and depends very much on the location factors and the material used.

The International Energy Agency IRENA has calculated that in 2019 the electricity production costs for PV electricity from a lithium-ion battery with a four-hour discharge time will be around 0.2 US dollars for one kWh of electricity. For electricity from solar thermal power plants, IRENA calculated an average electricity production cost of 0.182 US dollars per kilowatt hour for the same year.

THERMAL ENERGY STORAGE VERSES BATTERY

Several recent scientific studies have found that CSP power plants tend to be equipped with increasingly large thermal storage units because the integration of thermal storage reduces the cost per kilowatt hour generated. IRENA and the World Bank, as well as a research association around the Institute for Advanced Sustainable Studies IASS in Potsdam, state that battery storage is the better option below a storage time of two hours, but that solar thermal storage is the better choice above four hours. In the period between two and four hours of storage, specific location factors and circumstances determine the option to be chosen.

MAKING THE SUN SHINE AT NIGHT

"PV plus battery storage (BESS) is cheaper than CSP and thermal storage (TES) for short storage periods of up to 2-3 hours, regardless of the cost trend. CSP+TES is and remains cheapest for storage durations longer than 4 hours, except in the low-cost PV+BESS case where very strong PV+BESS learning is assumed and the tipping point shifts to 10 hours of storage. Therefore, under most conditions, an economically beneficial nighttime solar power market will be split between PV+BESS for short periods and CSP+TES for longer periods. When PV is combined with a TES and a Power Block instead of the battery, the system can benefit from the

decreasing specific costs with increasing storage duration and the lower specific storage costs for TES. However, PV+TES is more expensive than CSP+TES in all cost scenarios. The results mainly depend on the learning of PV and especially BESS, while they are robust for CSP+TES. If PV+BESS costs fall sharply, they capture most of the CSP niche, even if CSP is also advancing rapidly. For all segments, either PV+BESS or CSP+TES will deliver electricity at the lowest cost in all three cost scenarios."

From: "Making the Sun Shine at Night" (IASS POTSDAM AND OTHERS, 2021)

Heat 

The data for the price development of solar heat and solar process heat (Solar Heat for Industrial Processes, or SHIP) is still very sparse compared to the price of electricity. The application is only at the beginning of its development. Currently, according to a survey by IRENA and Solar Payback, just 786 MW of solar **process heat** capacity has been installed. Most plants use flatbed or vacuum tube technology. Globally, 57 projects with an installed capacity of 98 MW have been identified for evaluative data.

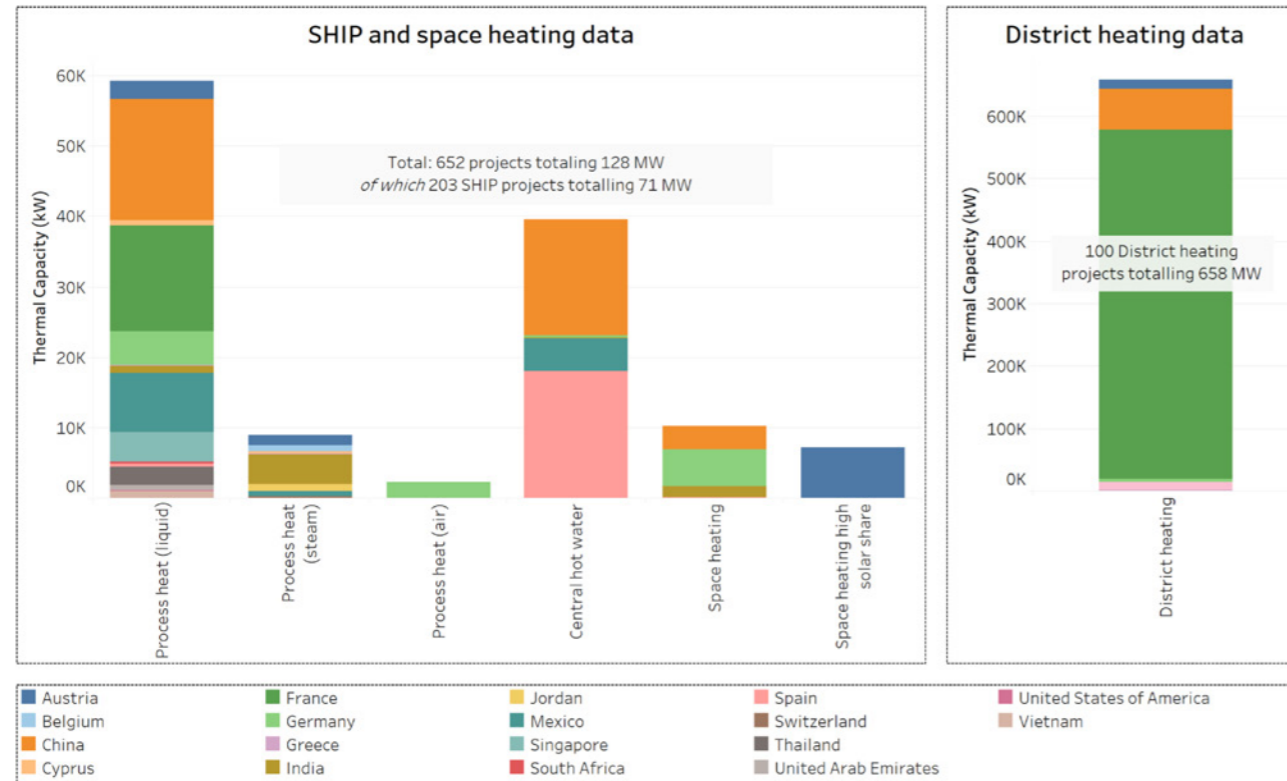

Solar Payback, database, 2021 (IRENA)

The reduction in costs and prices is also significant here: from 2004 - 2020, system costs for SHIP installations in Europe fell by an average of 43 percent. Even more than the system costs, namely by 58 percent, the levelized cost of heat (LCOH) for solar thermal energy fell to 76 US dollars per MWh in 2020.

Meanwhile, the data basis for heat from concentrating solar thermal is even narrower. Depending on the technology used and whether it is used as steam or hot water, it is slightly above flat-plate collectors, but below them in non-OECD countries.

In Central Europe, concentrating systems for heat generation are only just beginning to prove their importance and value. Parabolic trough systems of a German company in Antwerp and Oostende (Belgium) are pioneer systems, so to speak, but users are still holding back for the time being. This is apparently because CSP technology and its advantages for heat production are proven but unfortunately not yet sufficiently recognized.

After initial calculations and investigations, the German Aerospace Centre DLR has come to the clear conclusion that concentrating solar technology is well suited for use in less sunny regions like central Europe. According to this, the **heat production costs (LCOH)** depend strongly on the size of the solar field, the technology used and the required operating temperature.

Annual yields of heating systems with parabolic troughs are at least comparable to other technologies from about 80 °C temperature. In preliminary studies carried out by Rheinenergie (Cologne public utility company) for their **district heating network**, the lowest heat production costs for parabolic troughs were found in comparison with stationary collectors.

Even at high temperatures above 100 °C, solar heat can be provided efficiently. German municipal utilities more and more are showing interest in the technology, as necessary temperatures can be reliably provided by parabolic troughs and the annual yield values are good.

As with electricity, the same applies to heat: CSP plants are well suited for thermal storage in the heat sector and thus for achieving high coverage rates.

Parabolic trough technology in particular has great potential for decarbonizing heating systems. Their application would be a technological leap forward that would go hand in hand with a significant contribution to achieving the climate targets.

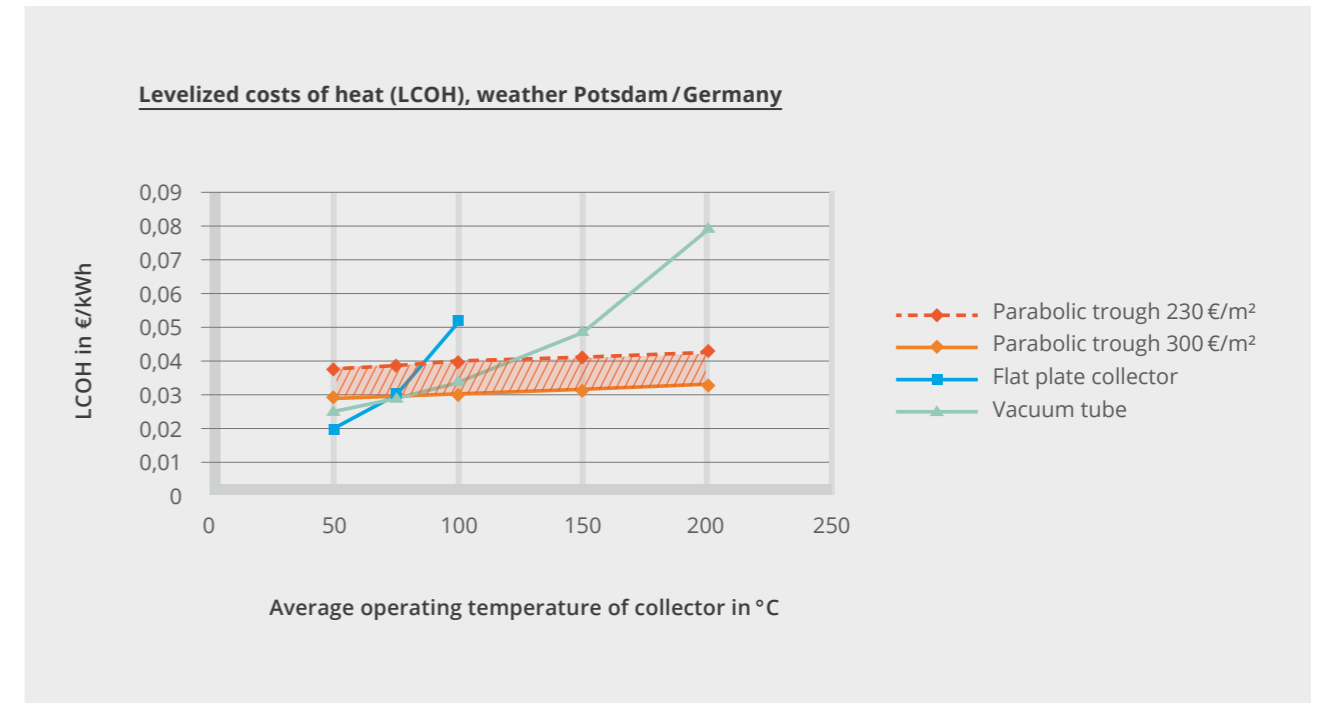

Concentrating solar thermal energy for heat in Germany (DLR)

Hydrogen

The price of hydrogen (H₂) produced with the help of CSP technology naturally depends very much on the framework conditions, the technologies used and the location of production.

In Germany, production costs for green hydrogen are currently estimated at between 3.5 and 7 euros per kilogram.

However, if production is carried out under climatically and economically more favourable conditions, for example in the desert regions of North Africa, **production costs** of significantly less than 3 EUROS per kilogram are feasible. Here, however, additional costs are incurred for the necessary infrastructure, liquefaction – which in turn requires energy – and transport. This leads to additional costs of 0.5 to 1 EURO per kilogram of hydrogen compared to central domestic production in Germany. Investments in the necessary plants and in the infrastructure for transport, such as pipelines and large distribution and processing centers (hubs), will reduce costs considerably over time. In all likelihood, however, they will only be made when a corresponding market volume emerges.

Price advantages from the use of concentrating solar thermal energy have not been sufficiently recognized so far. However, they exist in two respects.

The combination of photovoltaics and CSP in so-called **hybrid power plants** (see page 12) creates the possibility of combining low electricity production costs with high plant utilization. The planned PV/CSP hybrid power plant in Midelt (Morocco) uses the PV electricity to generate electricity during sunshine hours and at the same time, together with the CSP plant, charges the heat storage system. When the sun is not shining, this is used to provide electricity and, if necessary,

heat for electrolysis. This makes electricity production costs of 0.4 - 0.6 EURO possible for more than 7000 full-load hours. In addition, higher conversion efficiencies are achievable because the system can run under constant load.

The production costs for H₂ can be further reduced if the hybrid power plants are coupled with **high-temperature electrolysis (HTEL) technology**. Here, in addition to electricity, up to 20 per cent of the energy for the electrolysis process can be provided by high-temperature (200 - 800 °C), which is available cheaply in CSP power plants. In this way, more hydrogen can be produced per year with a corresponding power plant. In addition, operating costs are reduced. In the longer term, solar thermal water splitting at temperatures above 800 °C is also an option to further reduce costs.

 Kraftwerke können in Kombination mit anderen erneuerbaren Energien einen erheblichen Beitrag zur Kostensenkung der H₂-Produktion leisten

EXPORT POTENTIAL OF GREEN HYDROGEN

Several nations in the Sun Belt have now recognized the export potential of green hydrogen. Chile, for example, has enormous renewable energy potential, a developed gas and oil infrastructure, and developed energy policy institutions. In its national hydrogen strategy, the Chilean government assumes that clean hydrogen can lead to CO₂ savings of 17 to 27 percent. To this end, the government has set the goal of establishing a hydrogen export industry by 2030. Chile also has experience with solar thermal power plants and sees them as part of its future energy mix. Other examples are Australia, Morocco, South Africa and Namibia, as well as Spain. The industry association "Hydrogen Europe", for example, is calling for the production of 40 gigawatts of electrolysis capacity in Europe and North Africa as part of the European Green Deal. Much of this can lead to lower production costs with the help of CSP plants.



With a PV-CSP hybrid power plant, it is already today possible to realise hydrogen production costs of under three euros per kilogram. This makes green hydrogen competitive with hydrogen from fossil sources

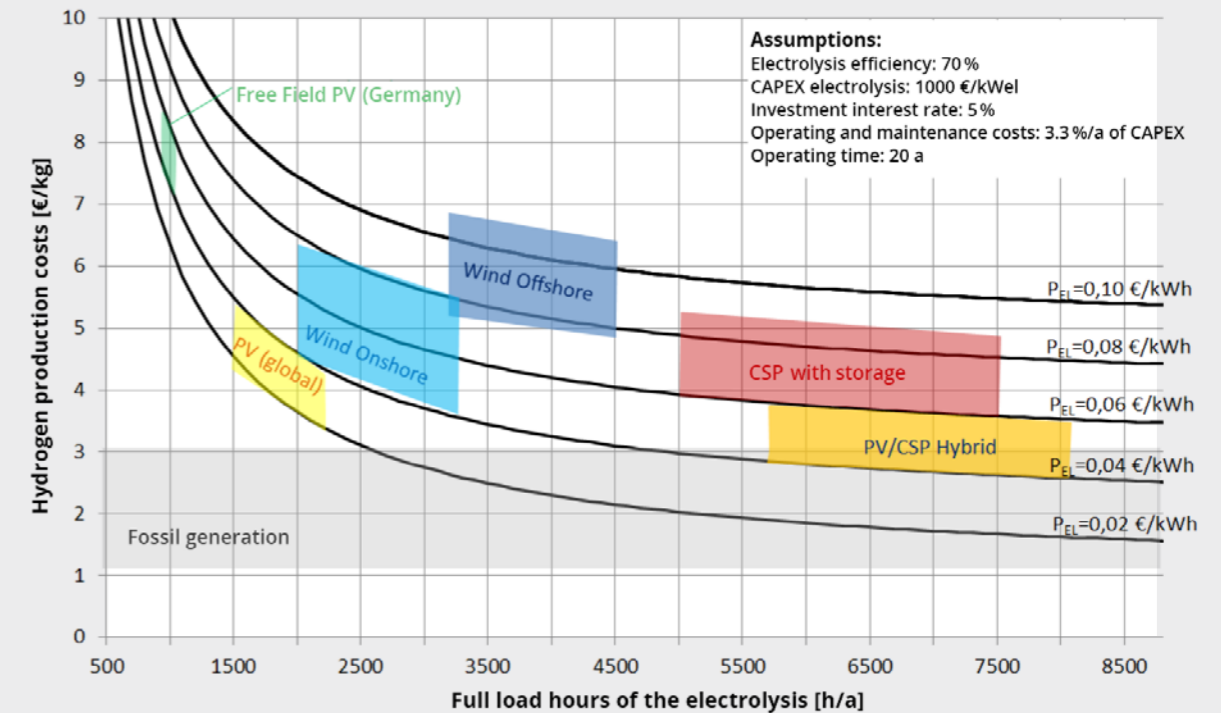

Influence of full load hours and electricity costs of renewable sources on the hydrogen production costs in electrolysis (DLR)

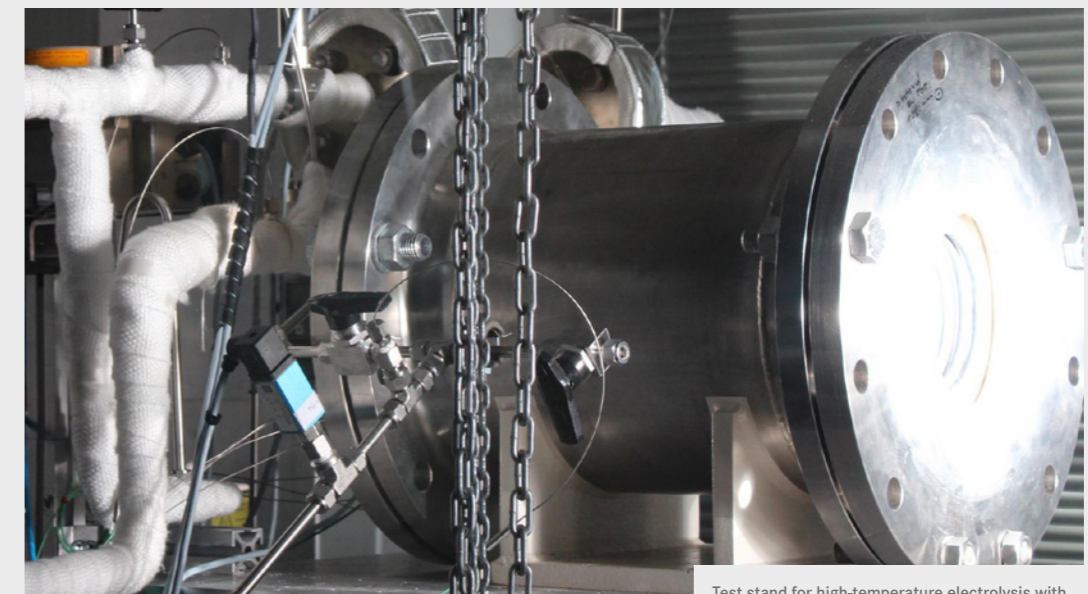

Test stand for high-temperature electrolysis with solar-thermal generated steam (DLR)

CSP can supply 25% of the world's energy



The global markets for solar thermal energy

Currently, there are about six gigawatts of solar thermal power plant capacity installed worldwide. Compared with the installed capacity for photovoltaics (627 GW) and wind (650 GW), this is relatively little. The reasons for this can be clearly analyzed and understood: Many countries that want to quickly get their energy transition underway look first at the price per kilowatt hour and not at the costs for the entire energy system. But the more intermittent renewables grow in the energy system, the more important the stabilizing effect of CSP power plants and their storage systems becomes.

A study by Greenpeace International, IRENA and others has shown that CSP power plants could satisfy around 25 percent of energy demand in 2050.

However, this market estimate and potential calculation is only about the share of CSP plants for the production of electricity. In addition, as described on p. 14-15, a market is developing for local and district heating as well as for industrial heat. This is by no means limited to countries with high direct solar irradiation but can also be applied for the common process temperatures at locations with medium solar irradiation in temperate climate zones, such as in Central Europe. This is also the case in Germany.

The inclusion of solar thermal generation for the production of hydrogen as the beacon of the global energy transition for use in mobility and industry is still in an initial phase (see p. 16-17). Here, potentials arise in particular from the high annual operating hours that can be achieved, as well as from the direct provision of low-cost heat.

However, the market for the production of electricity as well as for solar hydrogen is indeed largest where the highest solar irradiation (Direct Normal Irradiation DNI) leads us to expect the best solar harvest. In the Earth's sunbelt, optimal DNI values are 2000 to 3000 kilowatt-hours (kWh) per square meter per year. In the EU, we find very good conditions in the Mediterranean countries, especially in **Italy** and **Spain**. **Greece** and Mediterranean islands also come into question.

Most CSP power plants are currently located in **Spain** (2.3 GW), the **USA** (1.6 GW), **Morocco** (0.53 GW), **China** and **South Africa** (0.5 GW each). In the **United Arab Emirates**, around 0.8 GW are in operation or under construction.

The power plants are predominantly used to produce electricity. They are located in the sun belt of the world because solar radiation there enables the highest effectiveness for solar thermal power plants.

Spain currently operates the largest fleet of CSP power plants with 2.3 GW. According to the plans of the government in Madrid, around five GW of capacity are to be added by 2030. In talks with the EU, the Spanish government is suggesting that Spanish capacities should also be made available for the entire European energy supply. Spain is lobbying the EU for border adjustment schemes and transnational deployment options to create the regulatory conditions for this. Spain also sees the development of a suitable grid infrastructure as an essential contribution both to achieving the EU's ambitious climate targets and to the EU New Green Deal, which aims to combine climate policy ambitions with the financing of sustainable industrial infrastructure.

Most countries in the MENA region (Middle East North Africa) are particularly suitable for CSP deployment. Countries without fossil resources such as oil, gas and coal can use solar energy to make themselves independent of oil imports, which are a burden on government budgets. At the same time, they meet their climate commitments. Morocco has taken a particularly encouraging development in this regard. By 2020, the Kingdom had already drawn 42 per cent of its energy from renewable sources. After building up a further six gigawatts of capacity, this figure is set to rise to 52 percent in 2030.



Parabolic trough power plant Lebrija, Spain (SIEMENS, 2012)

Morocco is currently home to the world's largest CSP complex (Noor 1-3) with 510 MW of CSP and an additional 72 MW of photovoltaics. The three power plants heat storage between three and eight hours of deliverability. Under construction is the 800 MW hybrid power plant Noor Midelt, where for the first time energy from the CSP as well as from the PV plants will heat the molten salt in the storage tanks. This type of hybrid power plant is considered pioneering and trendsetting.

Another pioneer in the region is the **United Arab Emirates** (UAE). Here, 2.7 GW of renewable energies are to be built by the end of 2021. In addition to the 100 MW in the model complex Masdar City, a 950 MW CSP/PV project, DEWA IV, is to be connected to the grid in Dubai in 2021. Three CSP parabolic trough power plants with 200 MW each and storage for 12.5 hours will be built, as well as a solar tower CSP power plant with 100 MW capacity and storage for 15 hours. The PV share is to be 250 MW. The developers and builders of the plants (ACWA POWER / Saudi and Shanghai Electric / China) sell the kilowatt hour to the customer, the State Electricity Company of Dubai, for 0.073 US dollars. This is the lowest price ever offered for a power plant with CSP.

The favourable financing conditions of the 4.3-billion-dollar project, made possible by an international banking consortium, contribute significantly to the favourable electricity price. Another special feature of the project: the PV plant supplies the electricity for the day, while the peak load, which in the UAE is in the evening hours, comes from CSP power plants.

Other Arab countries also want to catch up. **Jordan** is currently in talks with the World Bank about CSP in the sunny but energy-poor country. In **Lebanon**, the groundwork has been laid for planning a 50 MW power plant in Hermel.

In **Kuwait**, the Shagaya complex, where 50 MW are already connected to the grid, is to be followed by another 200 MW. Saudi Arabia plans to build 2.7 GW of CSP around the NEOM mega-project as part of its innovation and reform initiative. Currently, the Saudi Electricity Company operates a 50 MW CSP power plant. The Saudi government has recently announced that it will start planning a pipeline to transport green hydrogen for the EU, which will be produced in the Saudi desert.

Israel has installed two power plants in the Negev Desert with a combined 231 MW - one with solar tower technology, the other with parabolic trough technology.





Parabolic trough power plant Delingha, China (SBP SONNE GMBH)

In Latin America, a dynamic market is developing in **Chile**. By 2050, Chile wants to fill 70 percent of its power grid with renewable energy. The Atacama Desert offers excellent solar conditions for the production of CSP – also for the mining industry there. In April 2021, Chile commissioned its first large CSP project, “Cerro Dominador”. A solar tower produces 100 MW of power, and the power plant’s integrated thermal storage has a capacity of 17.5 hours. **Peru** is also in a good position.

In 2019, the government of **South Africa** published its plan to build 600 GW of CSP capacity by 2030. Currently, CSP power plants with a capacity of 500 MW are already connected to the grid there, and a power plant with 100 MW is under construction and should be completed early 2022.

A traditional and proven market for CSP power plants is the **USA**. In the early 1970s, in the midst of the oil crisis, the government in Washington planned to increase the share of thermal energy in total energy production to 20 percent by 2020. Successive governments have repeatedly interrupted this ambitious plan, partly because of changes in the political agenda, but also because of falling prices for other energies. Nevertheless, the USA can once again develop into a dynamic market. The Department of Energy has adopted a “Sunshot Initiative 2030”, which aims to drive development in CSP so that the unsubsidized price for baseload CSP is US\$ 0.05 and for peak-load CSP US\$ 0.10.

In 2014, the Ivanpah CSP plant, the largest CSP plant to date at 392 MW, began supplying solar energy to the grid. In 2019, the power plant supplied the state of California with nearly 800 000 megawatt hours of electricity. The installed capacity of CSP power plants in the US was around 1.6 GW at the end of 2020.

A new player in the market with great ambition is **China**. By the end of 2020, China had installed around 0.5 GW of CSP. It has taken a very targeted approach to its planning - as in other areas. The National Energy Administration launched a planning project in 2016. According to this, 20 CSP power plants with a total capacity of 1.3 GW were each to receive a purchase price of around 0.17 US dollars if they managed to feed in by the end of 2018. In May 2020, seven of these projects with a total capacity of 450 MW were connected to the grid. All current technologies were tried out: four tower power plants of 150 MW each, two parabolic trough power plants of 150 MW each, plus a Fresnel power plant with a capacity of 50 MW. Outside this program, another CSP tower power plant with 50 MW capacity was connected to the grid. China has meanwhile started to roll out its experience with CSP in other markets, including the United Arab Emirates. Chinese banks have also stepped in with very favourable conditions.

Some interesting **trends** for the further global development of solar thermal power plants can be read from the recent investment decisions.

The capacities of individual CSP plants are increasing. In Spain, the country with the largest installed CSP capacity at present, plants with a capacity of 50 MW were predominantly built. However, this had neither technical nor economic reasons. The Spanish legislation merely wanted to ensure that CSP power plants were built at as many locations as possible as part of the planning process. In addition, the individual units were not to be so large that only large companies could participate in planning, construction and operation.

However, the recent trend has been for the new power plants to have at least 100 MW capacity. In addition, several plants are increasingly being built at the same site. For example, in the Noor Ouarzazate complex in Morocco (510 MW CSP and 72 MW PV). Similarly, in the DEWA project in Dubai (700 MW CSP, 250 MW PV). Larger projects also enable a more favourable price per power plant unit because of the shared infrastructure and due to the so-called economies of scale.

Solar thermal storage is becoming the standard for CSP power plants. The vast majority of plants built since 2016 have been built with storage units that have a storage time of four to ten hours. This also applies to the plants built in China. The low cost of energy (LCOE) is generally more favourable with storage than for CSP plants without storage. However, the decision on the size of a storage unit depends strongly on the intensity and seasonal fluctuations of the solar radiation at the location, the conditions of the energy purchase agreement and the specific capital costs.

In more and more countries, storage is also being added to CSP plants. This trend obviously illustrates that planners and decision-makers increasingly understand that solar thermal power plants stabilize the grid. This becomes more important the higher the share of renewables in the grid, whose natural fluctuation must be supplemented by a renewable resource if green electricity is to be produced.

As with other renewables, political and financial backing from planners and decision-makers – nationally and internationally – is necessary for CSP to have its full impact on future energy systems and the climate.

The growth of the market for CSP since 2012 has already passed a tipping point. In line with the development of other renewable energy technologies, there will also be more CSP power plants while costs continue to fall. But greater certainty from policymakers to build more plants would be welcome, so that cost reduction can be achieved by learning by doing.

FINANCING

Today, public investments accounts for around 25 percent in global investment in the financing of all renewable technologies. Public investments are roughly split between in-country financing and financing from other sources; typically, grants or concessional financing tools are used for the public financing of renewable energy investments. Concessional financing comprises loans with either interest rates below market value, long grace periods, or both. Increasing traditional public financing and expanding other innovative forms – such as guarantees, derivative instruments, and liquid facilities – will be crucial to scaling up CSP capacity, especially in emerging economies with little or no experience in its deployment.

Source: World Bank, IRENA, Climate Investment Fund, 2021



Local value creation

Solar thermal power plants promote a local content of work in user countries

One of the considerable advantages of CSP technology is the high proportion of local value added in the preparation, planning, construction and operation of the plants.

CSP technology can make an important contribution to industrial and socio-economic development, especially in the sunny, arid countries and regions of the world that are particularly suitable for the application of CSP technology for power generation. Thus, CSP offers policy-makers opportunities for active policy-making in four closely related areas: Climate and environmental policy, development policy, economic and industrial policy and foreign policy.

The sheer size of the project and the scope of work on a large infrastructure project like a solar power plant has direct and indirect effects on **employment**. Compared to other technologies, the share of local value creation is very high. This is partly due to the fact that other technologies often require greater reliance on the import of technology components. Depending on the stage of development of the country in which a CSP plant is built, the share of **local value creation can be up to 80 percent**.

According to corresponding experiences in Spain, about 2000 people are directly and indirectly employed for the construction and erection of a power plant with a capacity of 50 MW over a period of two years. Around 50 permanent jobs will be created for the operation of the plant. According to IRENA, direct and indirect employment creates about 18 workers per installed MW. According to the latest surveys, about 34 000 people are employed in the CSP industry worldwide.

A look at the variety of value-added activities required to build CSP power plants shows the need for local labour at many different levels of individual skill.

Elements of the value chain of a solar thermal power plant

Projects	<ul style="list-style-type: none"> + Project development + Detailed planning + Procurement + Construction and installation work + Owner + Location, Resources + Operation & Maintenance
Components	<ul style="list-style-type: none"> + Turbine, power unit + Storage, heat exchanger + Electrics, sensors, measurement + Control, automation + Piping, instrumentation, valves, insulation + Pumps, hydraulic drive, heat exchanger + Heat transfer fluid + Receiver, mirror, pipe connector + Collector, heliostat, solar field
Enabling	<ul style="list-style-type: none"> + Consulting service + Technical planning & support + Production equipment & automation + Testing, measurement, technical quality control + Cleaning technology + Infrastructure, other

DCSP



Solar process heat in the food industry, Salem, India (PROTARGET AG)

The range of skills and expertise required is very wide. It ranges from simple earthworks by construction companies to the highly qualified skill of control, monitoring and maintenance of the entire plant.

Essential for the development of a local industry is a stable demand for services and skills. If the countries remain isolated settlements, there will hardly be any significant industrial settlements. For many countries, it would be conceivable that areas of the value chain that require a higher level of specific knowledge would also settle, especially if they establish themselves as lead markets with stable demand.

Particular opportunities with regard to the social and economic effects of solar thermal power plants are their geographical location. They are usually located away from conurbations and therefore offer **development prospects** especially in structurally weak regions. Infrastructures such as transport routes, energy and water supply are created or improved. This facilitates the settlement of companies. Moreover, in addition to direct and indirect jobs, other employment effects are created. Due to steadily higher incomes for qualified work in and at the solar thermal power plants, the consumption of everyday goods increases. This leads to new employment in these areas as well.

The so-called „spill-over-effects“ apply all the more to countries that are heavily dependent on the import of energy sources such as gas, oil and coal for their energy production. The use of solar energy ends or reduces dependence on purchased fuels.

These are difficult to calculate because of price fluctuations on international energy markets. The financial pressure on countries that are dependent on imported fossil fuels is significantly reduced through the use of CSP technology, and at the same time their **balance of payments** is improved. This strengthens the countries' financial power and access to finance.

The use of CSP technology is based on a free, indigenous energy source: the sun. Its deployment lowers the total system cost of all locally generated energy and significantly reduces or ends uncertainty in future generation costs.

In sun-rich countries that still benefit from fossil fuel exports today, many jobs will be lost when demand for oil, gas and coal falls. New, high-quality jobs will be created in the CSP industry - for the post-oil era. Saudi Arabia, for example, is already planning a pipeline to Europe for the hydrogen that will also be produced by CSP power plants in the desert. The United Arab Emirates (UAE) plans to export more hydrogen than oil as early as 2030. The UAE is one of the pioneer countries in solar thermal energy. Morocco wants to export ammonia from green hydrogen in the future. And Chile is calculating the possibilities and opportunities of exporting green hydrogen to Asia.

The energy transition will entail a significant **readjustment of the raw material** flows for energy. New countries will become exporters and build up their own local industries.

CSP technology will play a significant role in this.



Top products

The performance spectrum of industry and research

German companies and research institutes have played a decisive role in developing CSP technology and making it marketable. Thanks to years of preliminary work in research and practical application in the market, they have played a major role in making CSP a reliable, cost-effective and affordable energy technology.

For example, the skills of German companies have contributed to the fact that the supply shares of German companies in the Moroccan 160 MW power plant NOOR I have totalled 40 percent, although the power plant was not built under German responsibility.

Other countries have meanwhile understood the enormous potential of CSP technology, invested in the development of research capacities and built up their own industries. China, for example, is single-mindedly developing its own CSP industry and penetrating other markets.

A CSP power plant uses **core components** for which German companies traditionally have a high level of expertise. These include turbines, special glass, high-quality pipe connections, insulation, coatings, drives and pumps, measurement technology and heat exchangers. German developers, technology consultants, certifiers and experts also have a globally recognized reputation in plant construction. They also offer technological expertise for designing optimized system solutions.

German companies can offer local operators of CSP plants their long-term project experience in the construction of plants of different types as a quality feature in competition. In the field of power plant operations and maintenance, a number of German companies have been operating successfully abroad for decades.

German consulting, quality work and testing can set standards worldwide. With the increased use of solar thermal power plants, the transfer of this know-how will contribute significantly to the growth of the knowledge base and competence in the sun-rich countries of the world for their own sustainable and resilient energy supply.

Conversely, CSP power plants secure and create value added and jobs in Germany and give impetus to new business start-ups – even in established sectors. A good example of this is a steam turbine manufacturer whose technology is now being used worldwide in solar thermal projects with steam turbines.

The experience that German companies in the CSP sector have gained in sunny foreign countries with energy storage is now beginning to pay off for the energy turnaround in Germany as well. In North Rhine-Westphalia, for example, the experience of thermal storage is now being applied to research the subsequent use of decommissioned coal-fired power plants. If successful, they can be converted into thermal storage power plants based on molten salt. Almost the entire infrastructure and many components of a coal-fired power plant that has been taken off the grid could be efficiently re-used in this way. DLR reckons that about half of the jobs at a site could be preserved in this way.

Institutes such as the German Aerospace Center (DLR), the Fraunhofer Institute for Solar Energy Research (ISE) and the Solar Institute Jülich (SIJ) and others have done fundamental **research** for CSP technology and are continuously involved in further optimizing the technology and its applications.

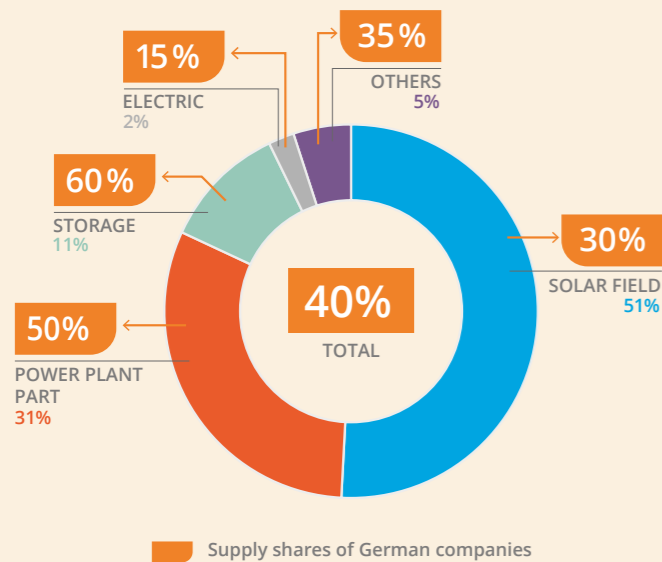

Supply shares of German companies in the Moroccan power plant NOOR I. (DCSP 2018)

Made in Germany

Through consistent cutting-edge research and technology development, German institutes and companies have provided important impetus and made a decisive contribution to the spread of CSP technology.

German „know-how“ and research – top worldwide.

Together with industrial partners, DLR is currently developing new components and processes for the use of new heat carriers and storage media. For example, DLR's Solar Institute Jülich (SIJ) is testing the use of storage materials for high temperatures of 500 - 1000 °C, as they occur in solar tower power plants, which are available locally in large quantities, are cheap and at the same time environmentally safe.

An investigation into the use of sand in an air-bulk heat exchanger (LSÜW) is well advanced. This storage method can be used in the Earth's sun belt, but also in southern Spain. A solar tower with such a storage system could supply an entire industrial area with thermal energy to provide process heat for the iron, steel, phosphorus, glass, ceramics and concrete industries. These are also responsible for a considerable share of CO₂ emissions in the sun-rich countries of the world.

It should be possible to reduce the costs for storage by up to 45 percent, and the costs for the plant construction itself

should also be lower than for salt storage, for example. DLR is also working on reactor concepts to make processes for the chemical industry possible with solar high-temperature heat.

One area of rapid development is the field of optical measurement methods for solar plants. Aerial drones are already monitoring the function and automatically recording the status of large solar fields. This means that defective system components which can significantly reduce operating costs can be detected and replaced more quickly.

DLR is also researching self-learning algorithms to enable the intelligent and autonomous operation of a solar power plant. In the future, solar power plants should be able to self-regulate their electricity production to match the current demand for electricity. This will improve the controllability of entire energy systems and also reduce costs.

Green electricity and artificial intelligence will be paired to the benefit of consumers and nature.

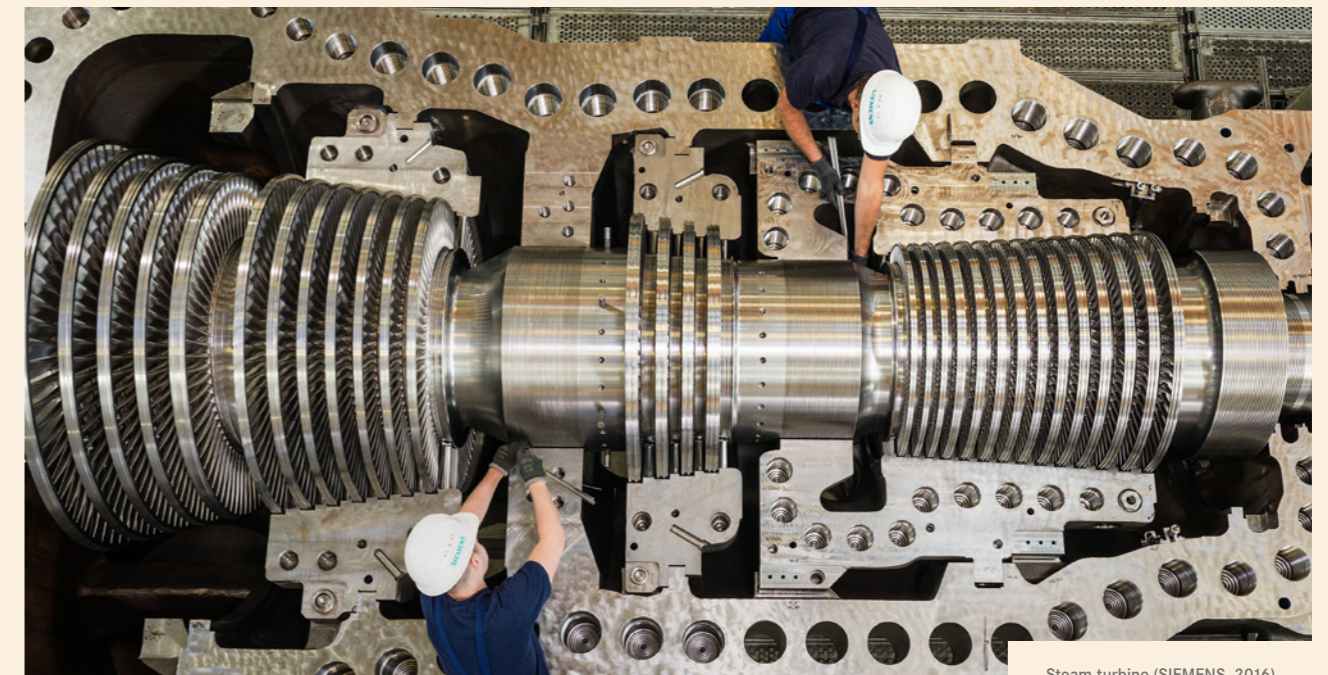

Steam turbine (SIEMENS, 2016)

Acknowledgements



BASF SE
www.basf.com



CSP Services GmbH
www.cspservices.de



**German Aerospace Centre (DLR)
Institute of Solar Research**
www.dlr.de/sf



enolcon gmbh
www.enolcon.com



Fichtner Solar GmbH & Co. KG
www.fichtner.de



Fraunhofer-Institut für Solare Energiesysteme ISE
www.ise.fraunhofer.de



Frenell GmbH
www.frenell.de



Hawe Hydraulik SE
www.hawe.de



hogrefe Consult
www.hogrefe-consult.com



IA Tech GmbH
www.iatech.de



KAEFER Isoliertechnik GmbH & Co. KG
www.kaefer.com



Kraftanlagen München GmbH
www.kraftanlagen.com



KSB Aktiengesellschaft
www.ksb.com



protarget AG
www.protarget-ag.com



**sbp gmbh
schlaich bergemann und partner**
www.sbp.de



Siemens Energy Global GmbH & Co. KG
www.siemens-energy.com



Solar-Institut Jülich der FH Aachen
www.sij.fh-aachen.de



Solarlite CSP Technology GmbH
www.solarlite.de



Suntrace GmbH
www.suntrace.de



toughTrough GmbH
www.toughtrough.com



TSK Flagsol GmbH
www.flagsol.de



Wacker Chemie AG
www.wacker.com

References

Bauer, Thomas; Odenthal, Christian ; Bonk, Alexander (2021): Molten Salt Storage for Power Generation, Chem. Ing. Tech. 2021, 93, No. 4, 114, DOI 10.1002/cite.202000137

Boie, Inga; Franke, Katja (2020): Synthesis of Key Issues Affecting CSP Development in Europe. Deliverable 10.1, MUSTEC Project, Fraunhofer ISI, Karlsruhe, https://www.mustec.eu/sites/default/files/reports/MUSTEC_D10.1_Synthesis%20of%20key%20issues%20affecting%20CSP%20development%20in%20Europe.pdf [accessed 18.12.2020]

DCSP Positionspapier 2020: Grüner Dampf und grüne Prozesswärme – produziert mit solarthermischen Anlagen in Deutschland. Deutscher Industrieverband Concentrated Solar Power, <https://docplayer.org/195347780-Positionspapier-positions-papier-gruener-dampf-und-gruene-prozesswaerme-produziert-mitsolarthermischen-anlagen-in-deutschland.html> [accessed 11.12.2020]

DCSP Positionspapier 2020: Grüner Wasserstoff aus der Wüste kosteneffizient produziert mit Strom und Wärme aus solarthermischen Kraftwerken. Deutscher Industrieverband Concentrated Solar Power, https://deutsche-csp.de/wp-content/uploads/200601_Deutsche-CSP_Positionspapier_Wasserstoff.pdf [accessed 11.12.2020]

Dersch, Jürgen; Dieckmann, Simon et. al (2019): LCOE Reduction Potential of Parabolic Trough and Solar Tower Technology in G20 Countries until 2030. SolarPACES Conference 2019, Deagu, Sudkorea, <https://aip.scitation.org/doi/abs/10.1063/5.0028883> [accessed 05.02.2021]

DLR (2020): Wasserstoff als ein Fundament der Energiewende, **Teil 1:** Technologien und Perspektiven für eine nachhaltige und ökonomische Wasserstoffversorgung. Deutsches Zentrum für Luft- und Raumfahrt e.V. (DLR), <https://www.dlr.de/content/de/downloads/publikationen/broschueren/2020/wasserstoffstudie-teil-1.pdf> [accessed 12.01.2021]

DLR (2020): Wasserstoff als ein Fundament der Energiewende, **Teil 2:** Sektorenkopplung und Wasserstoff: Zwei Seiten der gleichen Medaille. Deutsches Zentrum für Luft- und Raumfahrt e.V. (DLR), <https://www.dlr.de/content/de/downloads/publikationen/broschueren/2020/wasserstoffstudie-teil-2.pdf>;jsessionid=D4EA311BD8B1FDD7A7539203E823574.delivery-replication1?_blob=publicationFile&v=3 [accessed 24.11.2020]

DLR (2021): Solarthermische Kraftwerke. Wärme, Strom und Brennstoffe aus konzentrierter Sonnenenergie. Köln, <https://www.dlr.de/content/de/downloads/publikationen/broschueren/2020/studie-solarthermische-kraftwerke.pdf>;jsessionid=BB3418858B59BE2606B29EA3FEE85C62.delivery-replication1?__blob=publicationFile&v=8 [accessed 31.03.2021]

Epp, Bärbel; Oropeza, Marisol (Editors) (2017): Solar Heat for Industry. Projektbroschüre Solar Payback, gefördert durch BMU, <https://www.solar-payback.com/download/solar-heat-for-industry-april-2017/> [accessed 13.01.2021]

Gallardo, Felipe Ignacio; Monforti Ferrario, Andrea et. al (2021): A Techno-Economic Analysis of solar hydrogen production by electrolysis in the north of Chile and the case of exportation from Atacama Desert to Japan; International Journal of Hydrogen Energy; Volume 46, Issue 26; <https://www.sciencedirect.com/science/article/pii/S0360319920325842#>

Ho, Clifford K.; Iverson, Brian D. (2014): Review of high-temperature central receiver designs for concentrating solar power. In: Renewable & Sustainable Energy Reviews, Vol. 29, pp. 835-846, Elsevier, <https://doi.org/10.1016/j.rser.2013.08.099> [accessed 24.11.2020]

IEA International Energy Agency (2020): Task 64 – Solar Process Heat. <https://task64.iea-shc.org/> [accessed 15.01.2021]

IEA International Energy Agency (2020): World Energy Outlook 2020. OECD Publishing, Paris, <https://www.iea.org/reports/world-energy-outlook-2020> [accessed 20.01.2021]

IRENA (2020): Innovation Outlook Thermal Energy Storage, https://www.irena.org/-/media/Files/IRENA/Agency/Publication/2020/Nov/IRENA_Innovation_Outlook_TES_2020.pdf [accessed 04.12.2020]

IRENA (2020): Reaching Zero with Renewables: Eliminating CO₂ emissions from industry and transport in line with the 1.5 °C climate goal. International Renewable Energy Agency, Abu Dhabi. ISBN 978 - 92 - 9260 - 269 - 7, <https://www.irena.org/publications/2020/Sep/Reaching-Zero-with-Renewables> [accessed 07.01.2021]

IRENA (2020): Renewable Power Generation Costs in 2019. International Renewable Energy Agency, Abu Dhabi, <https://www.irena.org/publications/2020/Jun/Renewable-Power-Costs-in-2019> [accessed 07.01.2021]

Klasing, Freerk; Hirsch, Tobias et al. (2020): Techno-Economic Optimization of Molten Salt Concentrating Solar Power Parabolic Trough Plants with Packed-Bed Thermocline Tanks. Journal of Solar Energy Engineering, Vol. 142 (5), <https://asmedigitalcollection.asme.org/solarenergyengineering/article/142/5/051006/1074911/Techno-Economic-Optimization-of-Molten-Salt> [accessed 05.02.2021]

Krüger, Dirk; Epp, Bärbel et al. (2020): Developments in Solar Heat from Concentrating Solar Systems. Paper submitted at SolarPACES 2020, in review for AIP proceedings

Lilliestam, Johan; Ollier, Lana et al. (2020): The near- to mid-term outlook for concentrating solar power: mostly cloudy, chance of sun. Energy Sources, Part B: Economics, Planning, and Policy, DOI: 10.1080/15567249.2020.1773580, <https://doi.org/10.1080/15567249.2020.1773580> [accessed 21.01.2021]

Lovegrove, Keith; Stein, Wes (editors) (2021): Concentrating Solar Power Technology – Principles, Developments, and Applications. Elsevier Ltd. Woodhead Publishing, ISBN: 978-0-12-819970-1 (print), ISBN: 978-0-12-822472-4 (eBook)

Mehos, Mark; Price, Hank et. al. (2020): Concentrating Solar Power Best Practices Study. Technical Report NREL/TP-5500-75763, National Renewable Energy Laboratory (NREL), Golden (Colorado), USA, <https://www.nrel.gov/docs/fy20osti/75763.pdf> [accessed 04.12.2020]

Milani, Rodrigo; Caiado Couto, Lilia et. al. (2020): Promoting social development in developing countries through solar thermal power plants. Journal of Cleaner Production, Vol. 246, 119072, <https://www.sciencedirect.com/science/article/abs/pii/S0959652619339423?via%3Dihub> [accessed 17.12.2020]

O'Sullivan, Marlene; Edler, Dietmar (2020): Gross Employment Effects in the Renewable Energy Industry in Germany: An Input-Output Analysis from 2000 to 2018. In: Sustainability 12 (15), 6163, <https://doi.org/10.3390/su12156163> [accessed 04.12.2020]

Pitz-Paál, Robert (2020): Concentrating Solar Power in Future Energy (Third Edition). Pages 413-430, Elsevier, ISBN 9780081028865, <https://doi.org/10.1016/B978-0-08-102886-5.00019-0> [accessed 11.12.2020]

Pitz-Paál, Robert et al. (2017): Solarthermische Kraftwerke. In: Themen 2017, S. 88-93. Forschungsverbund Erneuerbare Energien. Innovationen für die Energiewende, 8.-9.11.2017, Berlin, ISSN 0939-7582, <https://elib.dlr.de/124274/> [accessed 11.12.2020]

REN21 (2020): Renewables 2020 – Global Status Report. UN Environment Programme, REN21 Secretariat, Paris, https://www.ren21.net/wp-content/uploads/2019/05/gsr_2020_full_report_en.pdf [accessed 18.12.2020]

Schöniger Franziska; Thonig Richard; Resch Gustav; Lilliestam Johan (2021): Making the sun shine at night: comparing the cost of dispatchable concentrating solar power and photovoltaics with storage. Energy Sources. Part B: Economics, Planning, and Policy, DOI: <https://www.tandfonline.com/doi/full/10.1080/15567249.2020.1843565> [accessed 09.01.2021]

Stadler, Ingo et. al. (2019): Thermal Energy Storage. In: Sterner, Michael; Ingo Stadler (2019): Handbook of Energy Storage – Demand, Technologies, Integration. S. 563-609, Springer Verlag Berlin Heidelberg.

Steinbacher, Karoline; Fichter, Tobias et. al. (2020): The role of coal in the energy mix of MENA countries and alternative pathways. Deutsche Gesellschaft für Internationale Zusammenarbeit (GIZ), https://www.giz.de/de/downloads/GIZ_2020_Role-of-coal-in-energy-mix-of-MENA-countries.pdf [accessed 18.11.2020]

Steinmann, Wolf-Dieter (2021): Thermal energy storage systems for concentrating solar power plants. In: Lovegrove, Keith; Stein, Wes: Concentrating Solar Power Technology (Second Edition). S. 399-440, Woodhead Publishing.

VDI-Richtlinie (2020): 3988 Solarthermische Prozesswärme. Beuth Verlag, Berlin

World Bank (2021): Concentrating Solar Power: Clean Power on Demand 24/7. Washington, DC. World Bank. <http://pubdocs.worldbank.org/en/849341611761898393/WorldBank-CSP-Report-Concentrating-Solar-Power-Clean-Power-on-Demand-24-7-FINAL.pdf> [accessed 01.02.2021]

CSP – the Multi-Talent

Solar power plants based on concentrating solar thermal (CSP) can make a significant contribution to the global energy transition: they can generate up to 25 % of the renewable energy needed worldwide. CSP plants produce green electricity with the energy of the sun. A decisive advantage of CSP technology is the storage capability of its energy: CSP plants supply electricity 24/7 – around the clock. At competitive prices. CSP storage capacities make the energy systems more stable, allowing

increased use of wind and PV by reducing curtailment. CSP plants can produce green heat. This is how solar energy enters local and district heating networks. CSP also provides sufficiently high temperatures for the process steam that industry so urgently needs – including for the production of green hydrogen. CSP is a technology that has been tried and tested for decades – and yet has only just begun to unfold its true potential and significance for the global energy system.



CO₂ = carbon dioxide | CSP = concentrating solar power | h = hour | MENA = Middle East and North Africa | MW = megawatt | PV = photovoltaic | RE = renewable energy

(THE WORLD BANK, IRENA, CLIMATE INVESTMENT FUNDS)