

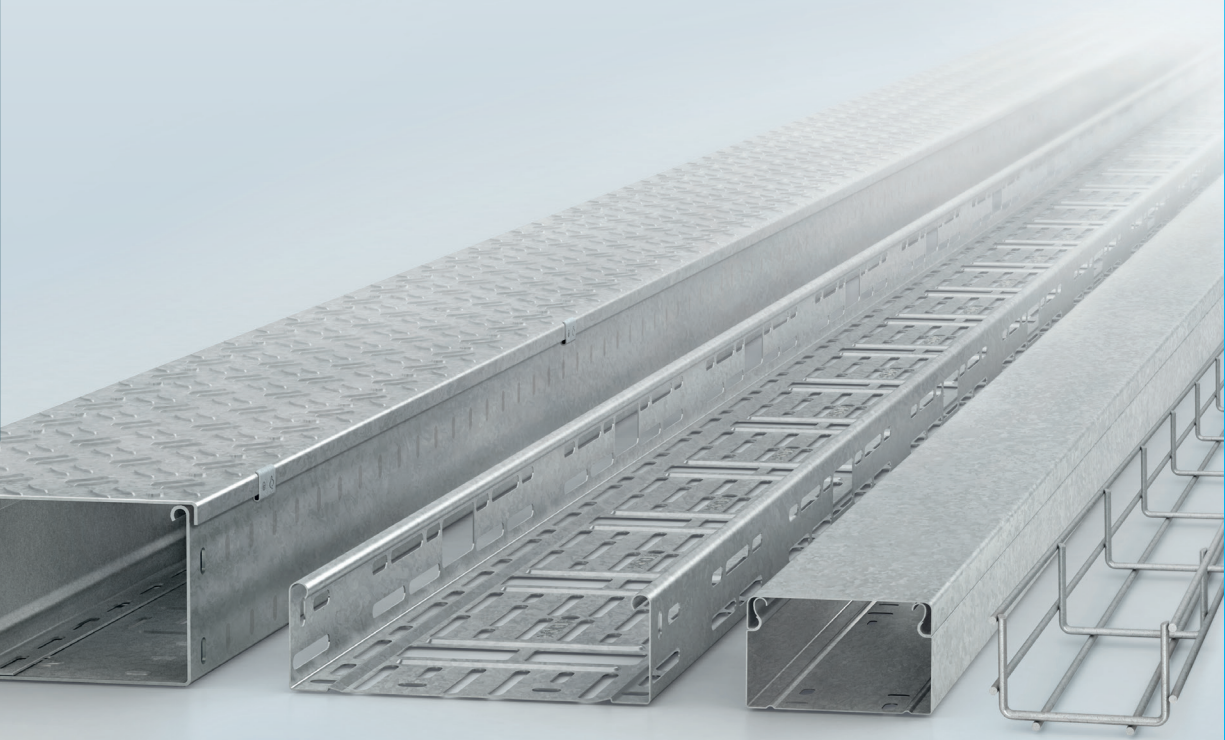

CTS

CABLE TRAY SYSTEMS



ICONS

New	35 Siderail height in mm	Operating temperature range	Hardware
Discontinued model	1 Wire diameter in mm	Fast install	Installation instructions
Halogen-free	78 170 Cover hole and depth in mm	Glow wire test acc. DIN EN 60695-2-10 / VDE 0471-2-10 acc. DIN EN 60695-2-11 / VDE 0471-2-11	Reference note
Silicone-free	30 Pipe diameter in mm		Information pages

Steel

B Steel, bare
V Steel, galvanized according to DIN EN ISO 19598 and DIN EN ISO 2081, blue passivated, (Replacement galvanized according to DIN EN ISO 4042)
VC Steel, galvanized according to DIN EN ISO 19598 and DIN EN ISO 2081, blue passivated and powdercoated
VZL Steel, electro galvanized according to DIN EN ISO 2081, blue passivated, top layer sealed
G Steel, galvanized according to DIN EN ISO 19598 and DIN EN ISO 2081, passivated, (Replacement galvanized according to DIN EN ISO 4042)
S Steel, pre-galvanized according to DIN EN 10346
F Steel, hot dip galvanized after fabrication (HDGAF) according to DIN EN ISO 1461 (Replacement according to DIN EN ISO 50 976)
FD Steel, hot dip galvanized after fabrication (HDGAF), double dip method
SB Steel, black-oxide finish
FG Steel, geomet® galvanized
DV Steel, wire galvanized according to DIN EN 10244
C1 Epoxy Coating, halogen-free
C COLOR Steel, pre-galvanized and powdercoated

Stainless Steel

E1 Material code: 1.4016	E4 Material code: 1.4404/AISI 316L	E7 Material code: 1.4547	E10 Material code: 1.4307/AISI 304L
E2 Material code: 1.4310	E5 Material code: 1.4571/AISI 316Ti	E8 Material code: 1.4430	E11 Material code: 1.4034
E3 Material code: 1.4301/AISI 304	E6 Material code: 1.4529	E9 Material code: 1.4362	E12 Material code: 1.4462
AL Aluminium, N = naturally anodized, P = mill-finished, C = powdercoated in RAL colours			
P Electrotechnical Porcelain, halogen-free	MS Brass	CU Copper	

Plastics/Elastomer

K01 PA - Polyamide, halogen-free	K14 POM - Polyoxymethylene, halogen-free
K02 PS - Polystyrene, halogen-free, impact resistant	K15 SBR - Styrene Butadiene Rubber, halogen-free
K03 PE - Polyethylene, halogen-free	K16 CR/NBR - Chloroprene/Nitrile Butadiene Rubber, halogenated
K04 PP - Polypropylene, halogen-free	K17 CR/SBR - Chloroprene/Styrene Butadiene Rubber, halogenated
K05 PC - Polycarbonate, halogen-free	K18 TPE - Thermoplastic Elastomers, halogen-free
K06 SBR/NBR - Styrene Butadiene Nitrile Rubber, halogen-free	K19 FS 31 - Moulding material 31 (Phenolic Resin), halogen-free
K07 CR - Neoprene (Chloroprene Rubber), halogenated	K20 SI - Silicone Rubber, halogen-free
K08 NBR - Nitrile Butadiene Rubber, halogen-free	K21 PUR - Polyurethanes, halogen-free
K09 PVC hard - Polyvinyl Chloride Hard, halogenated	K22 PET - Polyethylene Terephthalate, halogen-free
K10 PVC - Polyvinyl Chloride Soft, halogenated	K23 UP-GF - Glass-Fiber Reinforced Polyester, halogen-free
K11 ABS - Acrylnitrile Butadiene Styrene, halogen-free	K24 PBT - Polybutylene Terephthalate, halogen-free
K12 ASA - Acrylic Acid Ester-Styrene-Acrylonitrile Graft Copolymer, halogen-free	



Cable Tray System Products are classified by UL in accordance to NEMA VE1-2009 for USA and CAN/CSA - C22.2 No. 126.1-98 for Canada



Surface Metal Raceway System Products are listed by UL in accordance to UL 5 for USA and CAN/CSA - C22.2 No. 62-93 for Canada

Important notice: The information herein has been carefully checked for accuracy and is believed to be correct and current. No warranty, either expressed or implied, is made as to either its applicability to or its compatability with specific requirements of this information, nor for damages consequential to its use. All design characteristics, specifications, tolerances and similar information are subject to change without notice.

Alphabetical table of contents
Type listing

Page 4-6

Page 8-19

General Information

- Material Handling
- Finishes
- Corrosion Protection
- Installation Instructions



Support System

- Overhead Hangers
- Brackets
- C-Profiles
- Head Plates

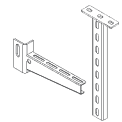

Wire Mesh Tray System

- Wire Mesh Tray
- Dividers
- Fittings
- Covers
- Accessories

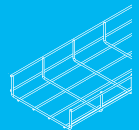

Cable Tray System

- Cable Tray
- Dividers
- Fittings
- Covers
- Accessories

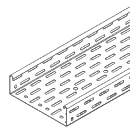

Floor-Mount Cable Tray System

- Floor-Mount Cable Tray
- Dividers
- Fittings
- Covers
- Accessories

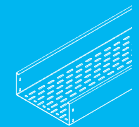

Cable Ladder System

- Cable Ladder
- Fittings
- Covers
- Accessories

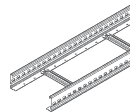

Vertical Cable Ladder System

- Vertical Cable Ladder
- Splice Plates
- Accessories



Long Span System

- Long Span Cable Tray
- Long Span Cable Ladder
- Fittings
- Accessories

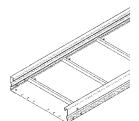

Channel Cable Tray

- Channel Cable Tray
- Fittings
- Accessories

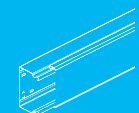

TABLE OF CONTENTS IN ALPHABETICAL ORDER

2	
2970 Framing Channel	128
2986 Framing Channel	129, 253
2996Z Toothed Framing Channel	130-131
2996ZD Back to back toothed framing channel	131
2997Z Framing Channel	130
A	
Adjustable Corner Bracket	138
Adjustable Horizontal Splice/Reducer/Blind End	200, 213, 226, 244, 248
Adjustable Splice Plate	264-265, 291, 296-297, 305-306, 311-312
Adjustable Vertical Elbow	267
Adjustable Vertical Splice Plate	200, 213, 226
Attachment Clip for Wire Mesh Tray	162
B	
Beam Clamp	95, 134-135
Beam Clamp with Locknut	140
Bearing for Framing Channel	252
Bendable Multifunction Splice Bar	159, 171
Blind End with Cover Lock	244, 248
Boltless Splice Plate	171, 193, 207
Bottom Connection Plate	193, 208, 300
Box/Wall Connector	96
Bracket	94, 101, 106, 113-114, 122, 163
C	
Cable Drop Out	161, 173
Cable Ladder	264
Cable Ladder Connection Bracket	267
Cable Ladder Mounting Bracket	268
Cable Retainer Clamp	335, 341
Cable Tray	194, 219
Carriage Bolt with Nut	132, 142, 256
Carriage Bolt with Shaft and Nut	142
C-Bracket for Wire Mesh Tray	164
Channel Cable Tray	327, 329-330, 338
Channel Nut	129, 134
Cito Line Wire Mesh Tray	156-157
Clamping Bracket	95
Column Support Bracket	139
Concrete Screw Anchor	145, 257
Counter Pressure Cradle for all Yoke-Clamps	148
Cover Clamp	234
Cover for 45° Horizontal Elbow	230
Cover for 90° Horizontal Elbow	187, 230, 317
Cover for 90° Horizontal Elbow (small radius)	269
Cover for Cable Tray/Ladder	229, 269
Cover for Distribution Cable Tray	185
Cover for Flexible Horizontal Fitting	230
Cover for Horizontal Cross	231
Cover for Horizontal Extension Tee	187, 229, 318
Cover for Horizontal Tee	188, 231, 269, 318
Cover for Long Span Cable Trays/Ladders	317
Cover for Vertical Inside Elbow	232
Cover for Vertical Outside Elbow Kit	231-232
Cover Removing Tool	252
D	
Distribution Cable Tray	184, 193, 207, 220
Divider	160, 172, 185, 196, 209, 222, 265, 291, 297, 306, 312, 331, 339
Dust Protection Strip	252
E	
Edge Protection	301
Edge Protection Plate	202, 215, 228, 301
Edge Protection Ring	146, 185, 194, 208, 220
Edge Protection Strip	145
Elbow 45°	242, 246, 331, 340
Elbow 90°	242, 246, 333
Enclosure Panel Kit for Vertical Ladder	281
End-Cap	328, 334, 341
Endplate	293, 299, 308, 314
End-Protection Ring	328, 335, 342
Expansion Anchor	144-145, 256
Extension Horizontal Tee	187, 198, 211, 223, 266, 292, 298, 307, 313
Extension Tee	243, 247
Exterior Cover Clamp	233
F	
Five Hole U-Support	133
Flange Clamp	139
Flanged U-Washer	132
Flexible Divider	242, 246
Flexible Horizontal and Vertical Elbow	156-157
Flexible Horizontal Elbow 0-90°	198, 211, 224
Floor Clamp	254
Floor Mounting Bracket	254
Floor Mounting Bracket (height: 100 mm)	254
Floor Mounting Bracket (height: 50 mm)	253
Floor Stand	255
Four Hole Tee Plate	133
G	
Gripping Channel Nut	129, 134
H	
Hammerset Flange Clip	140-141
Head Plate	105, 112, 120, 279
Heavy Duty Antiskid Cover (DIN 51130 class R10)	249
Heavy Duty Antiskid Cover for 45° Horizontal Elbow	249
Heavy Duty Antiskid Cover for 90° Horizontal Elbow	249
Heavy Duty Antiskid Cover for Horizontal Extension Tee	249
Heavy Duty Antiskid Cover for Horizontal Tee	250
Heavy Duty Cable Tray	195, 208-209, 219-220, 240-241, 245
Heavy Duty Cover Clamp	251, 282
Heavy Duty Divider	240-241, 245



H	
Heavy Duty I-Beam Clamping Assembly	112-113, 121, 136-137
Heavy Duty Square Washer/Anchor Plate	138
Heavy Duty Turnbolt Lock	250
Hex Head Bolt	141
Hex Head Bolt with Nut and Washer	95
Hexagonal Nut	144
Hexagonal Rod Coupling	144
Hold Down Clip for Wire Mesh Tray	164, 176
Horizontal Cross	200, 212, 225
Horizontal Elbow 45°	199, 211, 224
Horizontal Elbow 90°	187, 199, 212, 224, 293, 298, 307, 313
Horizontal Elbow 90° (small radius)	265
Horizontal Elbow Building Block	198, 211, 223, 292, 298, 307, 313
Horizontal Tee	187, 199, 212, 225, 243, 247, 266, 293, 299, 308, 314, 334
I	
I-Beam Clamping Assembly	135-136
Inside Elbow 45°	331, 339
Inside Elbow 90°	332
J	
J-Hook Bolt	159
L	
Ladder Drop Out	267, 315
Large Diameter Washer	143, 256
Large Square Splice Washer/Clamping Bracket	159, 171
Long Span Cable Ladder	305, 310-311
Long Span Cable Tray	290, 295-296
M	
Mounting Bracket for Heavy Duty Cable Tray	248
Mounting Clamp for Divider	160, 172, 265, 276, 279, 292, 297, 306, 312
Mounting Clamp for Long Span Ladders	315-316
Mounting Clip for Divider	161, 173
Mounting Kit for Enclosure Panel	281
Mounting Plate for Divider	197, 210, 222, 330, 339
Mounting Plate for Divider with M6 Stud	197, 210, 223
Mushroom Head Bolt	159, 171
O	
Offset Flange Bracket	96
Outside Elbow 45°	331, 339
Outside Elbow 90°	332
Outside Wide Radius Elbow (2x45°)	332, 340
Overhead Hanger	100, 104, 110, 118
Overhead Hanger and Wall Bracket	94
P	
Pair of Protective Caps	240, 242, 246
Pair of Protective End Caps	267, 294, 300, 309, 315
Pan-Head Torx Bolt	256
Peaked Snapon Cover for Wire Mesh Tray	158, 170

P	
Profile I 80	119, 280
Profile U 5050	105
Profile U 6040	111, 277
Protective End Cap	94, 100-101, 104, 106, 111, 114, 118, 122, 128, 130-132, 266, 277, 280, 320
Punch and Die Set for Hydraulic Tools	146
R	
Raised Cover Clamp	188, 234, 270, 319
Reducer	293, 299, 308, 314
Reducer/Blind End	200, 213, 225, 244, 248
Retaining Bracket	158, 170
Retaining Clip for Skirting Panel	254
Rungs for Vertical Cable Ladders	276, 279
S	
Self-Tapping Screw with Pan-Head	256
Serrated Flange Nut	141
Serrated Washer	144
Shelf Bracket	138
Skirting Panel	254-256
Sloped Sliding Nut	128
Socket Cap Bolt	141
Spacer for Overhead Hanger	100, 104, 111
Splice Plate	221, 264, 291, 296, 305, 311, 328, 330, 338
Splice Plate for Divider	160, 172, 185, 197, 210, 222, 265, 291, 297, 306, 312
Splice/Link Kit	201, 213, 226
Square Splice Washer	159, 171
Straight Splice Plate	105, 112, 119, 277, 279
Straight Strut Joiner	132
T	
Tee-Connector	119, 253
Threaded Rod, size M10	143
Threaded Rod, size M12	143
Threaded Rod, size M6	142
Threaded Rod, size M8	142
Three Hole Corner Angle	138, 268, 278, 316
Three Hole Corner Plate	133
Three Hole Splice Plate	132
Three Piece Splice Plate Kit	221
Trapeze Hanger for Wire Mesh Tray	162
Turnbolt Lock	186, 233, 251, 269, 319-320
Two Hole Corner Angle	137, 268, 277, 316
Two Hole Corner Angle for I 80	120, 280
U	
Universal Attachment Bracket	165, 177
Universal Splice Bolt for Wire Mesh Tray	159, 171

TABLE OF CONTENTS IN ALPHABETICAL ORDER

U

Universal Splice Plate	186, 196, 209, 222, 240-241, 245
Universal Wire Mesh Mounting Bracket	174
U-Shaped Splice Plate	196, 209, 221
U-Shaped Square Washer	159, 171

V

Vertical Cable Ladder	276, 278
Vertical Inside Elbow 45°	214, 226
Vertical Inside Elbow 90°	201, 214, 227
Vertical Inside Elbow 90° (2x45°)	243, 247
Vertical Outside Elbow 45°	214, 227
Vertical Outside Elbow 90°	201, 214, 227
Vertical Outside Elbow 90° (2x45°)	243, 247
Vertical Tee Down, crosswise	202, 215, 228
Vertical Tee Down, lengthwise	202, 215, 228

W

Wall and Box Mount Bracket	176
Wall and Box Mount Bracket for Wire Mesh Tray	161
Wall/Floor and Cross Connector Bracket	294, 300, 309, 315
Washer according to DIN EN ISO 7089 standard	143
Wide Radius Elbow (2x45°)	332-333, 340
Wide Radius Tee	333, 341
Wire Mesh Mounting Bracket	174-175
Wire Mesh Mounting Clamp	163
Wire Mesh Tray	168-169

Y

Yoke Clamp for Angle Sections	147
Yoke-Clamp	147



NOTES

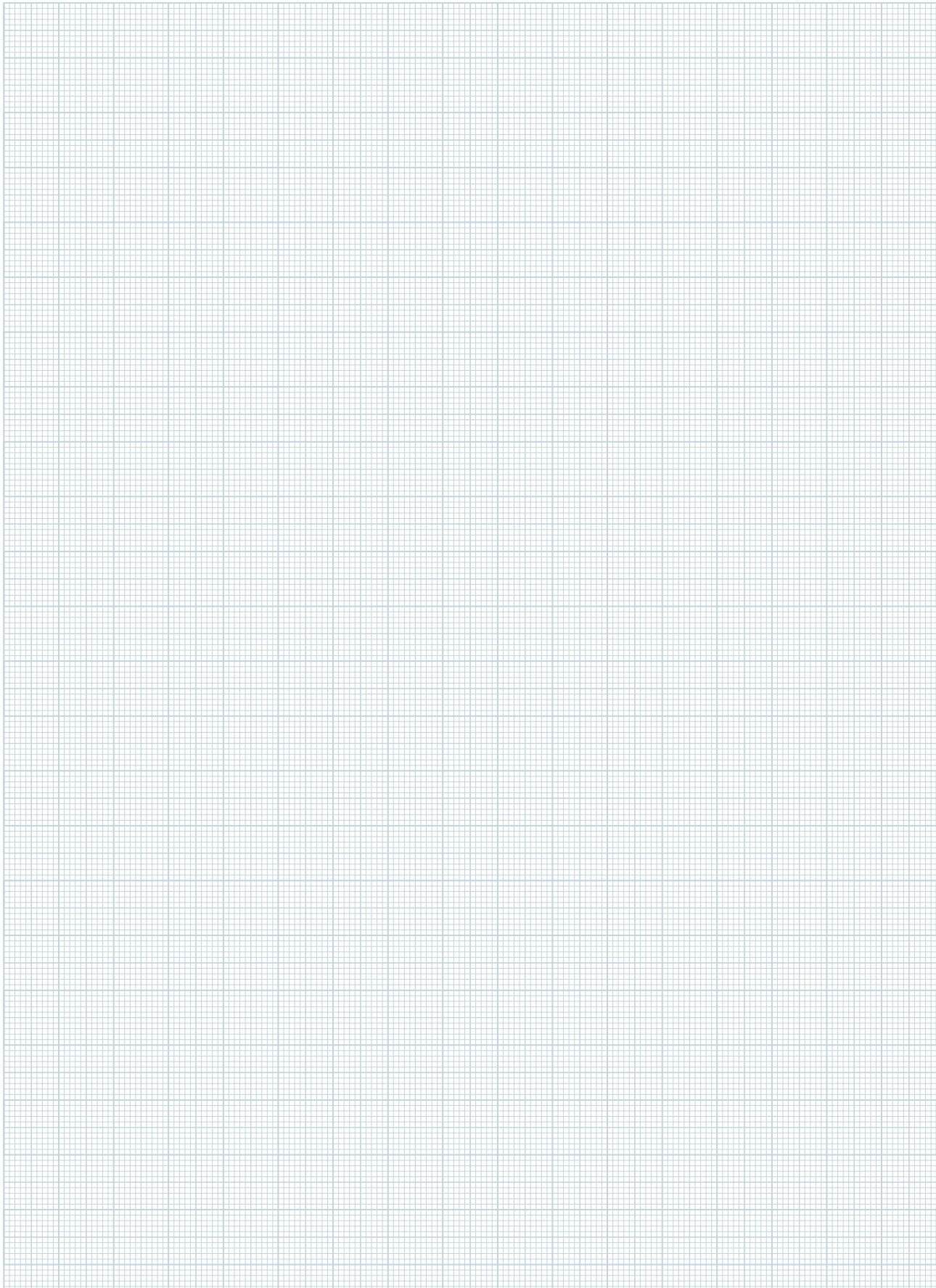

LIST OF ITEMS

model no.	EAN code	page	model no.	EAN code	page	model no.	EAN code	page
2970/2 SL	030309	128	DSLJ 400-0.75 S	179985	252	GRHKM 6X15 V	012442	159
2986/100 SL	894680	253	DSLJ 500-0.75 S	181131	252	GRKHV 173 S	166381	163
2986/1000 SL	894789	129	DSLJ 600-0.75 S	179992	252	GRMB 50 E3	912018	176
2986/200 SL	894703	129	EH-1420	744725	140	GRS 110.100 E3	930722	169
2986/200 SL	894703	253	EH-1420S	744787	141	GRS 110.200 E3	930739	169
2986/3 E3L	342228	129	EH-38	744688	140	GRS 110.300 E3	930746	169
2986/3 FL	193165	129	EH-38S	744749	141	GRS 110.400 E3	930753	169
2986/3 SL	193158	129	EH-814	744701	140	GRS 60.100 E3	801169	169
2986/3 SL	193158	253	EH-814S	744763	141	GRS 60.150 E3	801176	169
2986/300 SL	894727	129	FC-10T	745081	140	GRS 60.200 E3	801183	169
2986/300 SL	894727	253	FC-11	745005	140	GRS 60.300 E3	903528	169
2986/400 SL	894741	129	FC-12T	745104	140	GRS 60.400 E3	903542	169
2986/400 SL	894741	253	FC-13	745029	140	GRSM 6 V	280506	159
2986/500 SL	894765	129	FC-6T	745043	140	GRTB 6 E3	856008	172
2986/500 SL	894765	253	FC-7	744961	140	GRTB 6 S	174782	160
2986/600 SL	894772	129	FC-8T	745067	140	GRVS 4 E3	781201	171
2986/600 SL	894772	253	FC-9	744985	140	GRVS 5 E3	340118	171
2986/700 SL	899678	129	FLDM 6X30	945658	142	GRWB 10 E3	802005	175
2986/800 SL	899685	129	FLDM 6X45	207060	142	GRWGK 10 E3	931057	174
2986/900 SL	899715	129	FLDM 6X45 E3	343829	142	GSF 0406	119608	128
2996Z/3 E3L	078639	130	FLDM 6X60 V	064748	142	GSF 0408	119707	128
2996Z/3 FL	960675	130	FLM 10X25 E3	343881	142	GSM 0406	119202	128
2996Z-2.0/3 FL	235810	131	FLM 10X25 F	206902	142	GSM 0408	119301	128
2996Z-2.0/3 SL	179831	131	FLM 12X25 F	071715	132	GTAB 8 S	057924	162
2996ZD/3 FL	224081	131	FLM 12X30 F	207008	142	GTAK 50 E3	116720	173
2997Z/3 FL	173662	130	FLM 6X12	206209	142	GTAK 50 S	967483	161
AH-1420	744565	140	FLM 6X12	206209	256	GTL 20 E3	058075	171
AH-38	744527	140	FLM 6X12 E3	343805	142	GTL 20 V	058099	159
AH-814	744541	140	FLM 6X12 F	206407	142	GTL 30 E3	058112	171
AWG 110/140	891801	138	FLM 6X16 F	206506	142	GTL 30 V	058136	159
AWG 110/140 E3	892167	138	FLM 6X20 E4	101825	171	GTL 40 E3	058143	171
B 4.2X13-TX V	132614	256	FLM 6X20 G	057948	159	GTL 40 V	058167	159
BK 14	084401	147	FLM 8X13 F	206605	142	GTMB 65 S	058211	161
BK 18	084500	147	FLM 8X16 E3	343843	142	GTVL 300 E3	058822	171
BK 22	084609	147	FLM 8X16 F	206704	142	GTVL 300 V	058839	159
BK 30	084807	147	FLM 8X16 F	206704	256	GTWAB 50 S	058990	162
BK 34	084906	147	FLM 8X25 F	206803	142	GWU 12	109609	148
BK 42	085101	147	GMZF M10 F	947423	129	GWU 14	109708	148
BK 46	085200	147	GMZF M10 F	947423	134	GWU 18	110100	148
BK 54	085408	147	GMZF M12 F	947430	129	GWU 22	110209	148
BK 58	085507	147	GMZF M12 F	947430	134	GWU 30	110407	148
BK 64	085606	147	GMZF M6 F	947409	129	GWU 34	110506	148
BUK 14	096008	147	GMZF M6 F	947409	134	GWU 42	110704	148
BUK 18	096107	147	GMZF M8 F	947416	129	GWU 46	110803	148
BUK 22	096206	147	GMZF M8 F	947416	134	GWU 54	111008	148
BUK 30	096404	147	GMZF M10-18 E5	066414	129	GWU 58	111107	148
BUK 34	096503	147	GMZF M10-18 F	055661	129	GWU 64	111206	148
BUK 42	096701	147	GMZF M10-22 E5	066421	134	HDS 45.30 E3	165445	100
BUK 46	096800	147	GMZF M10-22 F	055517	134	HDS 45.30 F	165421	100
BUK 54	097005	147	GMZF M12-18 E5	069828	129	HDS 50.50 F	931705	104
BUK 58	097104	147	GMZF M12-18 F	055678	129	HDS 60.40 E3	931743	111
BUK 64	097203	147	GMZF M12-22 E5	069835	134	HDS 60.40 F	931729	111
BWK 14	090204	147	GMZF M12-22 F	055524	134	HI 80/1000	179206	118
BWK 18	090303	147	GMZF M6-18 E5	069842	129	HI 80/1200	179404	118
BWK 22	090402	147	GMZF M6-18 F	055647	129	HI 80/1500	179701	118
BWK 30	090600	147	GMZF M6-22 E5	069859	134	HI 80/200	178407	118
BWK 34	090709	147	GMZF M6-22 F	055487	134	HI 80/2000	180202	118
BWK 42	090907	147	GMZF M8-18 E5	069866	129	HI 80/300	178506	118
BWK 46	091003	147	GMZF M8-18 F	055654	129	HI 80/400	178605	118
BWK 54	091201	147	GMZF M8-22 E5	069873	134	HI 80/500	178704	118
BWK 58	091300	147	GMZF M8-22 F	055494	134	HI 80/600	178803	118
BWK 64	091409	147	GR 60.060 E3	968442	168	HI 80/700	178902	118
DAM 6X10	117666	144	GR 60.100 E3	343720	168	HI 80/800	179008	118
DAM 6X5	158126	144	GR 60.150 E3	343737	168	HI 80/900	179107	118
DAZ 10X10	842827	144	GR 60.200 E3	343744	168	HKVB 85-110 E2	149414	254
DAZ 10X10	842827	256	GR 60.300 E3	343768	168	HSK 10	195800	134
DAZ 10X30	842841	145	GRBP 6 E3	936960	174	HSK 10 E3	768509	134
DAZ 12X10	842865	144	GRD 100/7.5° E3	948123	170	HSK 15	195909	134
DAZ 12X10	842865	256	GRD 150/7.5° E3	948130	170	HSK 15 E3	768608	134
DAZ 16X25	842889	145	GRD 200/7.5° E3	948147	170	HSK 20	196104	134
DAZ 8X10	842803	144	GRD 300/7.5° E3	059591	170	HSK 20 E3	768707	134
DAZ 8X10	842803	256	GRD 400/7.5° E3	059614	170	HSK 25	196203	134
DHBKS 170 S	158645	252	GRD 60/7.5° E3	948116	170	HSK 25 E3	768806	134
DSLJ 100-0.75 S	179954	252	GRDHL 30 E3	092857	170	HSK 30	196005	134
DSLJ 200-0.75 S	179961	252	GRDHL 30 S	126996	158	HSK 30 E3	768905	134
DSLJ 300-0.75 S	179978	252	GRHKM 6X15 E3	012428	171	HSK 35	196302	134



model no.	EAN code	page	model no.	EAN code	page	model no.	EAN code	page
HSK 35 E3	769001	134	KA 100-600	347056	114	KTA 100	186907	101
HSK 40	196401	134	KA 100-600	347056	122	KTA 100	186907	106
HSK 40 E3	769100	134	KG S 100.203	903900	267	KTA 100	186907	113
HSKS 10	196425	95	KG S 100.303	903917	267	KTA 100 E3	330003	94
HSKS 10	196425	135	KG S 100.403	903924	267	KTA 100 E3	330003	101
HSKS 15	196432	95	KG S 100.503	903931	267	KTA 100 E3	330003	113
HSKS 15	196432	135	KG S 100.603	903948	267	KTA 150	187003	94
HSKS 20	196449	95	KG V 100 S	906772	264	KTA 150	187003	101
HSKS 20	196449	135	KI 80	192908	120	KTA 150	187003	106
HSKS 25	196456	95	KI 80	192908	279	KTA 150	187003	113
HSKS 25	196456	135	KIGV 80	193103	120	KTA 200	187102	94
HSKS 30	196463	95	KIQ 80	903009	120	KTA 200	187102	101
HSKS 30	196463	135	KIQ 80	903009	279	KTA 200	187102	106
HSKS 35	196470	95	KL 100.203/3-2970 S	134977	264	KTA 200	187102	113
HSKS 35	196470	135	KL 100.303/3-2970 S	134984	264	KTA 200 E3	330102	94
HSKS 40	196487	95	KL 100.403/3-2970 S	134991	264	KTA 200 E3	330102	101
HSKS 40	196487	135	KL 100.503/3-2970 S	136452	264	KTA 200 E3	330102	113
HU 4530/200 E3L	165049	100	KL 100.603/3-2970 S	135004	264	KTA 250	187201	94
HU 4530/200 FL	164820	100	KLAB 200	287406	267	KTA 250	187201	101
HU 4530/250 FL	164837	100	KLAB 300	287505	267	KTA 250	187201	106
HU 4530/300 E3L	165025	100	KLAB 400	287604	267	KTA 250	187201	113
HU 4530/300 FL	164844	100	KLAB 500	287703	267	KTA 300	187300	94
HU 4530/400 E3L	165018	100	KLAB 600	287802	267	KTA 300	187300	101
HU 4530/400 FL	164851	100	KLAS 100	295005	267	KTA 300	187300	106
HU 4530/500 E3L	164998	100	KLBK 100.203	903702	265	KTA 300	187300	113
HU 4530/500 FL	164868	100	KLBK 100.303	903719	265	KTA 300 E3	330201	94
HU 4530/600 E3L	164981	100	KLBK 100.403	903726	265	KTA 300 E3	330201	101
HU 4530/600 FL	164875	100	KLBK 100.503	903733	265	KTA 300 E3	330201	113
HU 4530/700 E3L	164974	100	KLBK 100.603	903740	265	KTA 350	187409	94
HU 4530/700 FL	164882	100	KLBKDV 200	938605	269	KTA 350	187409	101
HU 4530/800 E3L	164950	100	KLBKDV 300	938612	269	KTA 350	187409	106
HU 4530/800 FL	164899	100	KLBKDV 400	938629	269	KTA 350	187409	113
HU 5050/1000	858880	104	KLBKDV 500	938636	269	KTA 400	187508	94
HU 5050/1200	858927	104	KLBKDV 600	938643	269	KTA 400	187508	101
HU 5050/200	858705	104	KLT 100.203	903801	266	KTA 400	187508	106
HU 5050/250	858729	104	KLT 100.303	903818	266	KTA 400	187508	113
HU 5050/300	858743	104	KLT 100.403	903825	266	KTA 400 E3	330300	94
HU 5050/400	858767	104	KLT 100.503	903832	266	KTA 400 E3	330300	101
HU 5050/500	858781	104	KLT 100.603	903849	266	KTA 400 E3	330300	113
HU 5050/600	858804	104	KLTA 100.203	913701	266	KTA 450	187607	94
HU 5050/700	858828	104	KLTA 100.303	913725	266	KTA 450	187607	106
HU 5050/800	858842	104	KLTA 100.403	913749	266	KTA 450	187607	113
HU 5050/900	858866	104	KLTA 100.503	913763	266	KTA 500	187706	94
HU 6040/1000	891542	110	KLTA 100.603	913787	266	KTA 500	187706	106
HU 6040/1000 E3	891917	110	KLTA 6	282708	268	KTA 500	187706	113
HU 6040/1200	891566	110	{KLTB 96 F}	221486	268	KTA 500 E3	330409	94
HU 6040/1200 E3	891931	110	KLTDV 200	938759	269	KTA 500 E3	330409	113
HU 6040/1500	891573	110	KLTDV 300	938766	269	KTA 550	187805	94
HU 6040/1500 E3	891948	110	KLTDV 400	938773	269	KTA 550	187805	106
HU 6040/200	891450	110	KLTDV 500	938780	269	KTA 550	187805	113
HU 6040/200 E3	891825	110	KLTDV 600	938797	269	KTA 600	187904	94
HU 6040/2000	891580	110	KLWC 16	289707	265	KTA 600	187904	106
HU 6040/2000 E3	891955	110	KLWC 16	289707	292	KTA 600	187904	113
HU 6040/250	891467	110	KLWC 16	289707	297	KTA 600 E3	330508	94
HU 6040/250 E3	891832	110	KLWC 16	289707	306	KTA 600 E3	330508	113
HU 6040/300	891474	110	KLWC 16	289707	312	KTAC 100 S	192144	163
HU 6040/300 E3	891849	110	KLWC 16 E3	341641	292	KTAC 150 S	192168	163
HU 6040/400	891481	110	KLWC 16 E3	341641	297	KTAC 200 S	192175	163
HU 6040/400 E3	891856	110	KLWC 16 E3	341641	306	KTAC 300 S	192182	163
HU 6040/500	891498	110	KLWC 16 E3	341641	312	KTAS 100	917457	94
HU 6040/500 E3	891863	110	KLWC 16 F	570508	292	KTAS 100	917457	114
HU 6040/600	891504	110	KLWC 16 F	570508	297	KTAS 1000	189205	94
HU 6040/600 E3	891870	110	KLWC 16 F	570508	306	KTAS 1000	189205	114
HU 6040/700	891511	110	KLWC 16 F	570508	312	KTAS 200	188406	94
HU 6040/700 E3	891887	110	KLWC 18 F	179732	276	KTAS 200	188406	114
HU 6040/800	891528	110	KLWC 18 F	179732	279	KTAS 200 E3	330515	94
HU 6040/800 E3	891894	110	KSR 20 A	946761	146	KTAS 200 E3	330515	114
HU 6040/900	891535	110	KSR 20 A	946761	185	KTAS 300	188505	94
HU 6040/900 E3	891900	110	KSR 30 A	946778	146	KTAS 300	188505	114
I 80/3000 FL	181407	119	KSR 30 A	946778	185	KTAS 300 E3	330539	94
I 80/3000 FL	181407	280	KSR 30 A	946778	194	KTAS 300 E3	330539	114
I 80/6000 FL	181506	119	KSR 40 A	946785	146	KTAS 400	188604	94
I 80/6000 FL	181506	280	KSR 40 A	946785	208	KTAS 400	188604	114
KA 100-600	347056	94	KSR 40 A	946785	220	KTAS 400 E3	330553	94
KA 100-600	347056	101	KSV 100 S	906758	264	KTAS 400 E3	330553	114
KA 100-600	347056	106	KTA 100	186907	94	KTAS 500	188703	94

LIST OF ITEMS

model no.	EAN code	page	model no.	EAN code	page	model no.	EAN code	page
KTAS 500	188703	114	LER 60.100	865253	335	LUK 60.060	700103	330
KTAS 500 E3	330577	94	LER 80.080	887705	335	LUK 60.100	700202	330
KTAS 500 E3	330577	114	LES 60.150	518258	335	LUK 60.150	700301	330
KTAS 600	188802	94	LES 60.200	518265	335	LUK 60.200	700400	330
KTAS 600	188802	114	LFM 6X16-TX V	132607	256	LUK 80.080	508938	330
KTAS 600 E3	330591	94	LHS 100.100 E2	517466	335	LUT 100.100.100	792351	334
KTAS 600 E3	330591	114	LHS 100.100 E2	517466	341	LUT 40.040.040	792207	334
KTAS 700	188901	94	LHS 60.100 E2	517206	335	LUT 40.060.040	792252	334
KTAS 700	188901	114	LHS 60.150 E2	517305	335	LUT 60.060.060	515202	334
KTAS 800	189007	94	LHS 60.200 E2	517404	335	LUT 60.100.060	515301	334
KTAS 800	189007	114	LHS 80.080 E2	517442	335	LUT 60.100.100	515400	334
KTAS 900	189106	94	LLK 100.100	789757	329	LUT 60.150.060	515509	334
KTAS 900	189106	114	LLK 16.016	506705	327	LUT 60.150.100	515608	334
KTCL 100	904808	94	LLK 16.030	506804	327	LUT 60.150.150	515707	334
KTCL 200	904822	94	LLK 26.030	506903	327	LUT 60.200.060	515806	334
KTT 100	181605	122	LLK 40.040	508976	329	LUT 60.200.100	515905	334
KTT 150	181704	122	LLK 40.060	509003	329	LUT 60.200.150	516001	334
KTT 200	181803	122	LLK 60.060	509102	329	LUT 60.200.200	516100	334
KTT 250	181902	122	LLK 60.100	509201	329	LUT 80.080.080	792306	334
KTT 300	182008	122	LLK 60.150	509300	329	LUTC 100.100	799855	333
KTT 350	182107	122	LLK 60.200	509409	329	LUTC 40.060	514700	333
KTT 400	182206	122	LLK 80.080	789702	329	LUTC 60.060	514809	333
KTT 450	182305	122	LLKX 100.100 E3	879403	338	LUTC 60.100	514908	333
KTT 500	182404	122	LST 100	516667	330	LUTC 60.150	515004	333
KTT 550	182503	122	LST 16.016	516209	328	LUTC 60.200	515103	333
KTT 600	182602	122	LST 16.030	516308	328	LUTC 80.080	799800	333
KTTS 1000	183609	122	LST 26.030	516407	328	LUTCX 100.100 E3	880201	341
KTTS 200	182800	122	LST 40	516506	330	LUWB 100.100	789955	331
KTTS 300	182909	122	LST 60	516605	330	LUWB 40.040	511648	331
KTTS 400	183005	122	LST 80	516643	330	LUWB 40.060	511709	331
KTTS 500	183104	122	LSTX 100 E3	880300	338	LUWB 60.060	511808	331
KTTS 600	183203	122	LUAB 100.100	790753	331	LUWB 60.100	511907	331
KTTS 700	183302	122	LUAB 40.040	790609	331	LUWB 60.150	512003	331
KTTS 800	183401	122	LUAB 40.060	512706	331	LUWB 60.200	512102	331
KTTS 900	183500	122	LUAB 60.060	512805	331	LUWB 80.080	789900	331
KTTSS 1000	183692	95	LUAB 60.100	512904	331	LUWBX 100.100 E3	879601	340
KTTSS 200	183616	95	LUAB 60.150	513000	331	LUWC 100.100	791156	333
KTTSS 300	183623	95	LUAB 60.200	513109	331	LUWC 40.040	791002	333
KTTSS 400	183630	95	LUAB 80.080	790708	331	LUWC 40.060	513208	333
KTTSS 500	183647	95	LUABX 100.100 E3	879809	339	LUWC 60.060	513307	333
KTTSS 700	183661	95	LUAC 100.100	791958	332	LUWC 60.100	513406	333
KTTSS 800	183678	95	LUAC 40.040	791804	332	LUWC 60.150	513505	333
KTTSS 900	183685	95	LUAC 40.060	514205	332	LUWC 60.200	513604	333
KTU 100	174201	96	LUAC 60.060	514304	332	LUWC 80.080	791101	333
KTU 150	174300	96	LUAC 60.100	514403	332	LUWD 60.060	059386	333
KTU 200	174409	96	LUAC 60.150	514502	332	LUWD 60.100	831906	333
KTU 250	174508	96	LUAC 60.200	514601	332	LUWD 60.200	831944	333
KTU 300	174607	96	LUAC 80.080	791903	332	LUWDX 100.100 E3	879908	340
KTU 400	174805	96	LUAD 60.060	926480	332	LZTP 100	833009	330
KTU 500	175000	96	LUAD 60.100	832064	332	LZTP 100 E3	840403	339
KTU 600	175208	96	LUAD 60.200	832101	332	LZTP 150	833054	330
KU 5050	191956	105	LUADX 100.100 E3	880102	340	LZTP 200	833108	330
KU 6040	891771	112	LUIB 100.100	790357	331	M 10/1000	203208	143
KU 6040 E3	892136	112	LUIB 40.040	790203	331	M 10X25 912-8.8 V	186556	141
KUGV 5050	192151	105	LUIB 40.060	512201	331	M 10X35 912-8.8 V	186563	141
KWV 100 S	906796	265	LUIB 60.060	512300	331	M 10X50 912-8.8 V	186570	141
LED 100.100	792559	334	LUIB 60.100	512409	331	M 12/1000	345809	143
LED 16.016	517725	328	LUIB 60.150	512508	331	M 6/1000	919420	142
LED 16.030	517732	328	LUIB 60.200	512607	331	M 6X25 912-8.8 V	186587	141
LED 26.030	517749	328	LUIB 80.080	790302	331	M 6X35 912-8.8 V	186594	141
LED 40.040	517763	334	LUIBX 100.100 E3	879700	339	M 8/1000	203505	142
LED 40.060	517800	334	LUIC 100.100	791552	332	M 8X25 912-8.8 V	186617	141
LED 60.060	517909	334	LUIC 40.040	791408	332	M 8X35 912-8.8 V	186631	141
LED 60.100	518005	334	LUIC 40.060	513703	332	M 8X50 912-8.8 V	186648	141
LED 60.150	518104	334	LUIC 60.060	513802	332	MTC 105.100 V	711352	157
LED 60.200	518203	334	LUIC 60.100	513901	332	MTC 105.150 V	711369	157
LED 80.080	792504	334	LUIC 60.150	514007	332	MTC 105.200 V	711376	157
LEDX 100.100 E3	880409	341	LUIC 60.200	514106	332	MTC 105.300 V	711383	157
LER 100.100	887750	335	LUIC 80.080	791507	332	MTC 105.400 V	711390	157
LER 100.100	887750	342	LUID 60.060	082834	332	MTC 105.450 V	187492	157
LER 16.016	887606	328	LUID 60.100	831982	332	MTC 105.500 V	711413	157
LER 16.030	887637	328	LUID 60.200	832026	332	MTC 105.600 V	711420	157
LER 26.030	887668	328	LUIDX 100.100 E3	880003	340	MTC 54.050 V	711260	156
LER 40.040	865109	335	LUK 100.100	508945	330	MTC 54.100 V	711277	156
LER 40.060	865154	335	LUK 40.040	508921	330	MTC 54.150 V	711284	156
LER 60.060	865208	335	LUK 40.060	700004	330	MTC 54.200 V	711291	156



model no.	EAN code	page	model no.	EAN code	page	model no.	EAN code	page
MTC 54.300 V	711314	156	RA 85.400	243365	213	RBA 85.600	238309	211
MTC 54.400 V	711321	156	RA 85.400 F	546763	213	RBA 85.600 F	541904	211
MTC 54.450 V	187522	156	RA 85.500	243372	213	RBADV 100	275106	230
MTC 54.500 V	711338	156	RA 85.500 F	546770	213	RBADV 100 F	555406	230
MTC 54.600 V	711345	156	RA 85.600	243389	213	RBADV 150	275205	230
MTCC 100/7.5° S	154654	158	RA 85.600 F	546787	213	RBADV 150 F	555505	230
MTCC 150/7.5° S	154999	158	RADS 100.100 S	171118	244	RBADV 200	275304	230
MTCC 200/7.5° S	154661	158	RADS 100.200 S	171125	244	RBADV 200 F	555604	230
MTCC 300/7.5° S	154678	158	RADS 100.300 S	171132	244	RBADV 300	275502	230
MTCC 400/7.5° S	154685	158	RADS 100.400 S	171149	244	RBADV 300 F	555802	230
MTCC 450/7.5° S	238729	158	RADS 100.500 S	171156	244	RBADV 400	275601	230
MTCC 50/7.5° S	154975	158	RADS 100.600 S	171163	244	RBADV 400 F	555901	230
MTCC 500/7.5° S	155026	158	RADS 110.100 S	171170	248	RBADV 500	275700	230
MTCC 600/7.5° S	155033	158	RADS 110.200 S	171187	248	RBADV 500 F	556007	230
MTCDC 24 E2	191963	161	RADS 110.300 S	171194	248	RBADV 600	275908	230
MTCDC 24 E2	191963	173	RADS 110.400 S	171217	248	RBADV 600 F	556205	230
MTCE 105.100 V	711710	157	RADS 110.500 S	171224	248	RBADVRS 100-2.0 S	133215	249
MTCE 105.150 V	711727	157	RADS 110.600 S	171231	248	RBADVRS 200-2.0 S	133222	249
MTCE 105.200 V	711734	157	RAW 100.100 S	132522	244	RBADVRS 300-2.0 S	133239	249
MTCE 105.300 V	711741	157	RAW 100.300 S	132539	244	RBADVRS 400-2.0 S	133246	249
MTCE 54.100 V	711512	156	RAW 110.100	764204	226	RBADVRS 500-2.0 S	133253	249
MTCE 54.100 V	711536	156	RAW 110.100	764204	248	RBADVRS 600-2.0 S	133260	249
MTCE 54.200 V	711550	156	RAW 110.100 E3	840823	226	RBAS 100.100 S	129584	242
MTCE 54.300 V	711574	156	RAW 110.100 F	765201	226	RBAS 100.200 S	129591	242
MTCSC 22 E2	191444	164	RAW 110.300	764600	226	RBAS 100.300 S	129614	242
MTCSC 22 E2	191444	176	RAW 110.300	764600	248	RBAS 100.400 S	129621	242
MTCUP 100 E3	191819	177	RAW 110.300 E3	840908	226	RBAS 100.500 S	129638	242
MTCUP 100 S	191826	165	RAW 110.300 F	765607	226	RBAS 100.600 S	129645	242
NSA 7.5X50/FKG-T30 V	153930	145	RAW 60.100	763207	200	RBAS 110.100	862504	246
NSA 7.5X50/FKG-T30 V	153930	257	RAW 60.100 E3	845309	200	RBAS 110.200	862528	246
PKS M6/10-40 F	133871	139	RAW 60.100 F	540730	200	RBAS 110.300	862542	246
PKS M8/10-40 E3	126866	139	RAW 60.300	763603	200	RBAS 110.400	862566	246
PKS M8/10-40 F	077571	139	RAW 60.300 E3	845385	200	RBAS 110.500	862573	246
RA 100.200 S	132485	244	RAW 60.300 F	540754	200	RBAS 110.600	862597	246
RA 100.400 S	132492	244	RAW 85.100	243334	213	RBAV 110.100	922406	224
RA 100.500 S	132508	244	RAW 85.100 F	546732	213	RBAV 110.150	922413	224
RA 100.600 S	132515	244	RAW 85.300	243358	213	RBAV 110.200	922420	224
RA 110.050	764105	225	RAW 85.300 F	546756	213	RBAV 110.300	922444	224
RA 110.050 E3	840809	225	RBA 110.100	251209	224	RBAV 110.400	922468	224
RA 110.050 F	765102	225	RBA 110.100 F	547401	224	RBAV 110.500	922482	224
RA 110.150	764303	225	RBA 110.150	251254	224	RBAV 110.600	922505	224
RA 110.150 F	765300	225	RBA 110.150 F	547456	224	RBAV 60.100	923786	198
RA 110.200	764402	225	RBA 110.200	251308	224	RBAV 60.150	930456	198
RA 110.200	764402	248	RBA 110.200 F	547500	224	RBAV 60.200	923809	198
RA 110.200 E3	840861	225	RBA 110.300	251407	224	RBAV 60.300	923823	198
RA 110.200 F	765409	225	RBA 110.300 F	547609	224	RBAV 60.400	923847	198
RA 110.350	764709	225	RBA 110.400	251506	224	RBAV 60.500	923861	198
RA 110.350 F	765706	225	RBA 110.400 F	547708	224	RBAV 60.600	923885	198
RA 110.400	764808	225	RBA 110.500	251605	224	RBAV 85.100	923663	211
RA 110.400	764808	248	RBA 110.500 F	547807	224	RBAV 85.200	923687	211
RA 110.400 E3	840946	225	RBA 110.600	947478	224	RBAV 85.300	923700	211
RA 110.400 F	765805	225	RBA 110.600 F	133352	224	RBAV 85.400	923724	211
RA 110.500	764907	225	RBA 60.100	225200	199	RBAV 85.500	923748	211
RA 110.500 E3	840960	225	RBA 60.100 F	535200	199	RBAV 85.600	923762	211
RA 110.500 F	765904	225	RBA 60.150	225309	199	RBAVD 100	922529	230
RA 110.600	858606	225	RBA 60.150 F	535255	199	RBAVD 150	930463	230
RA 110.600	858606	248	RBA 60.200	225408	199	RBAVD 200	922543	230
RA 110.600 E3	149742	225	RBA 60.200 F	535309	199	RBAVD 300	922567	230
RA 110.600 F	149759	225	RBA 60.300	225606	199	RBAVD 400	922581	230
RA 60.050	763108	200	RBA 60.300 F	535408	199	RBAVD 500	922604	230
RA 60.150	763306	200	RBA 60.400	225705	199	RBAVD 600	922628	230
RA 60.150 F	928651	200	RBA 60.400 F	535507	199	RDAH 30 E3	233069	188
RA 60.200	763405	200	RBA 60.500	225804	199	RDAH 30 E3	233069	234
RA 60.200 E3	845347	200	RBA 60.500 F	535606	199	RDAH 30 E3	233069	270
RA 60.200 F	540747	200	RBA 60.600	225903	199	RDAH 30 E3	233069	319
RA 60.400	763801	200	RBA 60.600 F	535705	199	RDAH 30 S	233076	188
RA 60.400 E3	845422	200	RBA 85.100	237807	211	RDAH 30 S	233076	234
RA 60.400 F	540761	200	RBA 85.100 F	541409	211	RDAH 30 S	233076	270
RA 60.500	763900	200	RBA 85.200	237906	211	RDAH 30 S	233076	319
RA 60.500 E3	845446	200	RBA 85.200 F	541508	211	RDB 85.100 V	132546	255
RA 60.500 F	540778	200	RBA 85.300	238002	211	RDB 85.200 V	132553	255
RA 60.600	764006	200	RBA 85.300 F	541607	211	RDB 85.300 V	132560	255
RA 60.600 E3	845460	200	RBA 85.400	238101	211	RDB 85.400 V	132577	255
RA 60.600 F	540785	200	RBA 85.400 F	541706	211	RDB 85.500 V	132584	255
RA 85.200	243341	213	RBA 85.500	238200	211	RDB 85.600 V	132591	255
RA 85.200 F	546749	213	RBA 85.500 F	541805	211	RDHF 9 E2	920457	234

LIST OF ITEMS

model no.	EAN code	page	model no.	EAN code	page	model no.	EAN code	page
RDHFS 9 VZL	182985	251	RES 110.600 F	022717	224	RFB 110.150	814404	227
RDHFS 9 VZL	182985	282	RES 60.100	226009	199	RFB 110.200	814459	227
RDHK 110 E2	911868	233	RES 60.100 E3	333561	199	RFB 110.300	814503	227
RDHK 60 E2	911851	233	RES 60.100 F	535804	199	RFB 110.400	814558	227
RDRS 100-2.0 S	149421	249	RES 60.150	226108	199	RFB 110.500	814602	227
RDRS 2	270002	186	RES 60.150 F	535859	199	RFB 110.600	140367	227
RDRS 2	270002	233	RES 60.200	226207	199	RFB 85.100	025091	214
RDRS 2	270002	251	RES 60.200 E3	333578	199	RFB 85.200	025121	214
RDRS 2	270002	320	RES 60.200 F	535903	199	RFB 85.300	025145	214
RDRS 2 E3	337606	186	RES 60.300	226405	199	RFB 85.400	025169	214
RDRS 2 E3	337606	233	RES 60.300 E3	333585	199	RFB 85.500	025183	214
RDRS 2 E3	337606	320	RES 60.300 F	536009	199	RFB 85.600	025213	214
RDRS 2/50	270101	186	RES 60.400	226504	199	RFD 110.100	927722	227
RDRS 2/50 E3	337651	186	RES 60.400 E3	845200	199	RFD 110.150	927739	227
RDRS 200-2.0 S	149438	249	RES 60.400 F	536108	199	RFD 110.200	927746	227
RDRS 300-2.0 S	149445	249	RES 60.500	226603	199	RFD 110.300	927760	227
RDRS 400-2.0 S	149452	249	RES 60.500 E3	845231	199	RFD 110.400	927784	227
RDRS 500-2.0 S	149469	249	RES 60.500 F	536207	199	RFD 110.500	927807	227
RDRS 600-2.0 S	149476	249	RES 60.600	226702	199	RFD 110.600	927821	227
RDRS 9	269907	233	RES 60.600 E3	845262	199	RFD 60.100	844319	201
RDRS 9	269907	269	RES 60.600 F	536306	199	RFD 60.100 F	935406	201
RDRS 9 E3	337705	233	RES 85.100	238408	212	RFD 60.150	844333	201
RDRS 9 F	563463	233	RES 85.100 F	542000	212	RFD 60.200	844340	201
RDRS 9X2	269884	250	RES 85.200	238507	212	RFD 60.200 F	935420	201
RDSV 100	258208	185	RES 85.200 F	542109	212	RFD 60.300	844364	201
RDSV 100 E3	860609	185	RES 85.300	238606	212	RFD 60.300 F	935444	201
RDSV 100 F	258260	185	RES 85.300 F	542208	212	RFD 60.400	844371	201
RDSV 50	258109	185	RES 85.400	238705	212	RFD 60.400 F	935468	201
RDSV 50 E3	860500	185	RES 85.400 F	542307	212	RFD 60.500	844388	201
RDSV 50 F	258246	185	RES 85.500	238804	212	RFD 60.500 F	935482	201
RDV 100	261406	229	RES 85.500 F	542406	212	RFD 60.600	844395	201
RDV 100 E3	336906	229	RES 85.600	238903	212	RFD 60.600 F	935505	201
RDV 100 F	263608	229	RES 85.600 F	542505	212	RFD 85.100	927609	214
RDV 150	261505	229	RESDV 100	276202	230	RFD 85.200	927623	214
RDV 150 F	263707	229	RESDV 100 E3	338405	230	RFD 85.300	927647	214
RDV 200	261604	229	RESDV 100 F	557202	230	RFD 85.400	927661	214
RDV 200	261604	269	RESDV 150	276301	230	RFD 85.500	927685	214
RDV 200 E3	337002	229	RESDV 150 F	557301	230	RFD 85.600	927708	214
RDV 200 F	263806	229	RESDV 200	275007	230	RFDDV 110.100	927968	232
RDV 300	261802	229	RESDV 200 E3	338504	230	RFDDV 110.150	927975	232
RDV 300	261802	269	RESDV 200 F	557400	230	RFDDV 110.200	927982	232
RDV 300 E3	337101	229	RESDV 300	274901	230	RFDDV 110.300	928002	232
RDV 300 F	264001	229	RESDV 300 E3	338603	230	RFDDV 110.400	928026	232
RDV 400	261901	229	RESDV 300 F	557608	230	RFDDV 110.500	928040	232
RDV 400	261901	269	RESDV 400	276509	230	RFDDV 110.600	928064	232
RDV 400 E3	337200	229	RESDV 400 E3	338702	230	RFDDV 85.100	927845	232
RDV 400 F	264100	229	RESDV 400 F	557707	230	RFDDV 85.200	927869	232
RDV 500	262007	229	RESDV 500	276608	230	RFDDV 85.300	927883	232
RDV 500	262007	269	RESDV 500 E3	338801	230	RFDDV 85.400	927906	232
RDV 500 E3	337309	229	RESDV 500 F	557806	230	RFDDV 85.500	927920	232
RDV 500 F	264209	229	RESDV 600	276806	230	RFDDV 85.600	927944	232
RDV 600	262205	229	RESDV 600 E3	338900	230	RFDU 100.100-1.5 S OV	191536	243
RDV 600	262205	269	RESDV 600 F	558001	230	RFDU 100.200-1.5 S OV	191543	243
RDV 600 E3	337507	229	RESDVRS 100-2.0 S	133154	249	RFDU 100.300-1.5 S OV	191550	243
RDV 600 F	264407	229	RESDVRS 200-2.0 S	133161	249	RFDU 100.400-1.5 S OV	191567	243
REK 110	253203	223	RESDVRS 300-2.0 S	133178	249	RFDU 100.500-1.5 S OV	191574	243
REK 110 E3	334902	223	RESDVRS 400-2.0 S	133185	249	RFDU 100.600-1.5 S OV	191581	243
REK 110 F	549207	223	RESDVRS 500-2.0 S	133192	249	RFDU 110.100-1.5 S OV	191666	247
REK 60	227600	198	RESDVRS 600-2.0 S	133208	249	RFDU 110.200-1.5 S OV	191673	247
REK 60 E3	334803	198	RESK 50.050	210305	187	RFDU 110.300-1.5 S OV	191680	247
REK 60 F	537006	198	RESK 50.100	210503	187	RFDU 110.400-1.5 S OV	191697	247
REK 85	239603	211	RESKDV 100	274208	187	RFDU 110.500-1.5 S OV	191710	247
REK 85 F	543205	211	RESKDV 50	276004	187	RFDU 110.600-1.5 S OV	191727	247
RES 110.100	251803	224	RESS 100.100 S	129652	242	RFSDDV 60.100	844524	231
RES 110.100 F	548002	224	RESS 100.200 S	129669	242	RFSDDV 60.150	844562	231
RES 110.150	251858	224	RESS 100.300 S	129676	242	RFSDDV 60.200	844586	231
RES 110.150 F	548057	224	RESS 100.400 S	129683	242	RFSDDV 60.300	844623	231
RES 110.200	251902	224	RESS 100.500 S	129690	242	RFSDDV 60.400	844647	231
RES 110.200 F	548101	224	RESS 100.600 S	129713	242	RFSDDV 60.500	844661	231
RES 110.300	252008	224	RESS 110.100	862702	246	RFSDDV 60.600	844685	231
RES 110.300 F	548200	224	RESS 110.200	862726	246	RGE 110.100	256006	226
RES 110.400	252107	224	RESS 110.300	862740	246	RGE 110.100 F	551804	226
RES 110.400 F	548309	224	RESS 110.400	862764	246	RGE 110.150	256051	226
RES 110.500	252206	224	RESS 110.500	862771	246	RGE 110.150 F	551859	226
RES 110.500 F	548408	224	RESS 110.600	862795	246	RGE 110.200	256105	226
RES 110.600	252350	224	RFB 110.100	814350	227	RGE 110.200 F	551903	226



model no.	EAN code	page	model no.	EAN code	page	model no.	EAN code	page
RGE 110.300	256204	226	RKB 400	270705	301	RKSDV 300	279104	231
RGE 110.300 F	552009	226	RKB 400 E3	335800	228	RKSDV 300 F	563005	231
RGE 110.400	256303	226	RKB 400 E3	335800	301	RKSDV 400	279203	231
RGE 110.400 F	552108	226	RKB 400 F	564002	202	RKSDV 400 F	563104	231
RGE 110.500	256402	226	RKB 400 F	564002	215	RKSDV 500	279302	231
RGE 110.500 F	552207	226	RKB 400 F	564002	228	RKSDV 500 F	563203	231
RGE 110.600	140374	226	RKB 400 F	564002	301	RKSDV 600	279500	231
RGE 110.600 F	149773	226	RKB 500	270804	202	RKSDV 600 F	563401	231
RGE 60.100	231201	201	RKB 500	270804	215	RL 60.100	219407	194
RGE 60.100 F	539802	201	RKB 500	270804	228	RL 60.150	219605	194
RGE 60.150	231300	201	RKB 500	270804	301	RL 60.200	219803	194
RGE 60.150 F	539857	201	RKB 500 E3	335909	228	RLCI 60.100 S	135332	193
RGE 60.200	231409	201	RKB 500 E3	335909	301	RLCI 60.200 S	135356	193
RGE 60.200 F	539901	201	RKB 500 F	564101	202	RLCI 60.300 S	135370	193
RGE 60.300	231607	201	RKB 500 F	564101	215	RLCPV 85.100 OV	031610	207
RGE 60.300 F	540006	201	RKB 500 F	564101	228	RLCPV 85.200 OV	031627	207
RGE 60.400	231706	201	RKB 500 F	564101	301	RLCPV 85.300 OV	031634	207
RGE 60.400 F	540105	201	RKB 600	271009	202	RLCPV 85.400 OV	031641	207
RGE 60.500	231805	201	RKB 600	271009	215	RLU 110.100 E3	332809	219
RGE 60.500 F	540204	201	RKB 600	271009	228	RLU 110.200 E3	332908	219
RGE 60.600	231904	201	RKB 600	271009	301	RLU 110.300 E3	333004	219
RGE 60.600 F	540303	201	RKB 600 E3	336104	228	RLU 110.400 E3	333103	219
RGE 85.100	242405	213	RKB 600 E3	336104	301	RLU 60.100	219506	194
RGE 85.100 F	545803	213	RKB 600 F	564309	202	RLU 60.100 E3	331604	194
RGE 85.200	242504	213	RKB 600 F	564309	215	RLU 60.150	219704	194
RGE 85.200 F	545902	213	RKB 600 F	564309	228	RLU 60.200	219902	194
RGE 85.300	242603	213	RKB 600 F	564309	301	RLU 60.200 E3	331703	194
RGE 85.300 F	546008	213	RKBA 10	206100	145	RS 110.100	245802	219
RGE 85.400	242702	213	RKBA 5	077991	145	RS 110.100 F	247004	219
RGE 85.400 F	546107	213	RKBA 6	934805	145	RS 110.200	246007	219
RGE 85.500	242801	213	RKS 110.100	254804	225	RS 110.200 F	247202	219
RGE 85.500 F	546206	213	RKS 110.100 F	550609	225	RS 110.300	246205	219
RGE 85.600	242900	213	RKS 110.150	254859	225	RS 110.300 F	247400	219
RGE 85.600 F	546305	213	RKS 110.150 F	550654	225	RS 110.400	246403	219
RGV 110	253302	226	RKS 110.200	254903	225	RS 110.400 F	247608	219
RGV 110 E3	335107	226	RKS 110.200 F	550708	225	RS 110.500	246601	219
RGV 110 F	253401	226	RKS 110.300	255009	225	RS 110.500 F	247806	219
RGV 60	227709	200	RKS 110.300 F	550807	225	RS 110.600	140497	219
RGV 60 E3	335008	200	RKS 110.400	255108	225	RS 110.600 F	133680	219
RGV 60 F	227808	200	RKS 110.400 F	550906	225	RS 60.100	222605	195
RGV 85	239702	213	RKS 110.500	255207	225	RS 60.100 F	223800	195
RGV 85 F	239801	213	RKS 110.500 F	551002	225	RS 60.200	222803	195
RKB 100	270200	202	RKS 110.600	135745	225	RS 60.200 F	224005	195
RKB 100	270200	215	RKS 110.600 F	149599	225	RS 60.300	223008	195
RKB 100	270200	228	RKS 60.100	229604	200	RS 60.300 F	224203	195
RKB 100 E3	335503	228	RKS 60.100 F	538607	200	RS 60.400	223206	195
RKB 100 F	563500	202	RKS 60.150	229703	200	RS 60.400 F	224401	195
RKB 100 F	563500	215	RKS 60.150 F	538652	200	RS 60.500	223404	195
RKB 100 F	563500	228	RKS 60.200	229802	200	RS 60.500 F	224609	195
RKB 150	270309	202	RKS 60.200 F	538706	200	RS 60.600	223602	195
RKB 150	270309	228	RKS 60.300	230006	200	RS 60.600 F	224807	195
RKB 150 F	563609	202	RKS 60.300 F	538805	200	RS 85.100	235209	208
RKB 150 F	563609	228	RKS 60.400	230105	200	RS 85.100 F	236404	208
RKB 200	270408	202	RKS 60.400 F	538904	200	RS 85.200	235407	208
RKB 200	270408	215	RKS 60.500	230204	200	RS 85.200 F	236602	208
RKB 200	270408	228	RKS 60.500 F	539000	200	RS 85.300	235605	208
RKB 200	270408	301	RKS 60.600	230303	200	RS 85.300 F	236800	208
RKB 200 E3	335602	228	RKS 60.600 F	539109	200	RS 85.400	235803	208
RKB 200 E3	335602	301	RKS 85.100	241200	212	RS 85.400 F	237005	208
RKB 200 F	563708	202	RKS 85.100 F	544608	212	RS 85.500	236008	208
RKB 200 F	563708	215	RKS 85.200	241309	212	RS 85.500 F	237203	208
RKB 200 F	563708	228	RKS 85.200 F	544707	212	RS 85.600	236206	208
RKB 200 F	563708	301	RKS 85.300	241408	212	RS 85.600 F	237401	208
RKB 300	270606	202	RKS 85.300 F	544806	212	RSB 110.100	814008	226
RKB 300	270606	215	RKS 85.400	241507	212	RSB 110.150	814053	226
RKB 300	270606	228	RKS 85.400 F	544905	212	RSB 110.200	814107	226
RKB 300	270606	301	RKS 85.500	241606	212	RSB 110.300	814152	226
RKB 300 E3	335701	228	RKS 85.500 F	545001	212	RSB 110.400	814206	226
RKB 300 E3	335701	301	RKS 85.600	241705	212	RSB 110.500	814251	226
RKB 300 F	563906	202	RKS 85.600 F	545100	212	RSB 110.600	140381	226
RKB 300 F	563906	215	RKSDV 100	278701	231	RSB 85.100	035113	214
RKB 300 F	563906	228	RKSDV 100 F	562602	231	RSB 85.200	035137	214
RKB 300 F	563906	301	RKSDV 150	278800	231	RSB 85.300	035151	214
RKB 400	270705	202	RKSDV 150 F	562701	231	RSB 85.400	035175	214
RKB 400	270705	215	RKSDV 200	278909	231	RSB 85.500	035199	214
RKB 400	270705	228	RKSDV 200 F	562800	231	RSB 85.600	035229	214

LIST OF ITEMS

model no.	EAN code	page	model no.	EAN code	page	model no.	EAN code	page
RSD 110.100	928200	227	RSSTAU 108.100 V	141890	255	RSV 110.400 S	259403	220
RSD 110.150	928217	227	RSSTAU 108.200 V	141913	255	RSV 50.050	257706	184
RSD 110.200	928224	227	RSSTAU 108.300 V	141920	255	RSV 50.050 E3	333523	184
RSD 110.300	928248	227	RSSTAU 108.400 V	141937	255	RSV 50.050 F	258307	184
RSD 110.400	928262	227	RSSTAU 108.500 V	141944	255	RSV 50.100	257805	184
RSD 110.500	928286	227	RSSTAU 108.600 V	141951	255	RSV 50.100 E3	333547	184
RSD 110.600	928309	227	RSSUP 100.100 S OV	180349	241	RSV 50.100 F	258406	184
RSD 60.100	844418	201	RSSUP 100.200 S OV	180332	241	RTA 110.100	252503	223
RSD 60.100 F	935604	201	RSSUP 100.300 S OV	180325	241	RTA 110.100 E3	334209	223
RSD 60.150	844432	201	RSSUP 100.400 S OV	180318	241	RTA 110.100 F	548606	223
RSD 60.200	844449	201	RSSUP 100.500 S OV	180295	241	RTA 110.150	252602	223
RSD 60.200 F	935628	201	RSSUP 100.600 S OV	180288	241	RTA 110.150 F	548651	223
RSD 60.300	844463	201	RSSUP 110.100 S OV	180271	245	RTA 110.200	252701	223
RSD 60.300 F	935642	201	RSSUP 110.200 S OV	180264	245	RTA 110.200 E3	334308	223
RSD 60.400	844470	201	RSSUP 110.300 S OV	180257	245	RTA 110.200 F	548705	223
RSD 60.400 F	935666	201	RSSUP 110.400 S OV	180240	245	RTA 110.300	252800	223
RSD 60.500	844487	201	RSSUP 110.500 S OV	180233	245	RTA 110.300 E3	334407	223
RSD 60.500 F	935680	201	RSSUP 110.600 S OV	180226	245	RTA 110.300 F	548804	223
RSD 60.600	844494	201	RSSSZS 85.40 F	166497	254	RTA 110.400	252909	223
RSD 60.600 F	935703	201	RSSSZS 85.80 F	166510	254	RTA 110.400 E3	334506	223
RSD 85.100	928088	214	RSSSZS 95.40 F	154227	254	RTA 110.400 F	548903	223
RSD 85.200	928101	214	RSSSZS 95.80 F	152964	254	RTA 110.500	253005	223
RSD 85.300	928125	214	RSU 110.100	245901	220	RTA 110.500 E3	334605	223
RSD 85.400	928149	214	RSU 110.100 F	247103	220	RTA 110.500 F	549009	223
RSD 85.500	928163	214	RSU 110.200	246106	220	RTA 110.600	253159	223
RSD 85.600	928187	214	RSU 110.200 F	247301	220	RTA 110.600 E3	334698	223
RSDDV 110.100	928446	232	RSU 110.300	246304	220	RTA 110.600 F	038824	223
RSDDV 110.150	928453	232	RSU 110.300 F	247509	220	RTA 60.100	226801	198
RSDDV 110.200	928460	232	RSU 110.400	246502	220	RTA 60.100 E3	333608	198
RSDDV 110.300	928484	232	RSU 110.400 F	247707	220	RTA 60.100 F	536405	198
RSDDV 110.400	928507	232	RSU 110.500	246700	220	RTA 60.150	226900	198
RSDDV 110.500	928521	232	RSU 110.500 F	247905	220	RTA 60.150 F	536450	198
RSDDV 110.600	928545	232	RSU 110.600	150137	220	RTA 60.200	227006	198
RSDDV 85.100	928323	232	RSU 110.600 F	150052	220	RTA 60.200 E3	333707	198
RSDDV 85.200	928347	232	RSU 60.100	222704	195	RTA 60.200 F	536504	198
RSDDV 85.300	928361	232	RSU 60.100 F	223909	195	RTA 60.300	227204	198
RSDDV 85.400	928385	232	RSU 60.200	222902	195	RTA 60.300 E3	333806	198
RSDDV 85.500	928408	232	RSU 60.200 F	224104	195	RTA 60.300 F	536603	198
RSDDV 85.600	928422	232	RSU 60.300	223107	195	RTA 60.400	227303	198
RSDU 100.100-1.5 S OV	191598	243	RSU 60.300 F	224302	195	RTA 60.400 E3	333905	198
RSDU 100.200-1.5 S OV	191611	243	RSU 60.400	223305	195	RTA 60.400 F	536702	198
RSDU 100.300-1.5 S OV	191628	243	RSU 60.400 F	224500	195	RTA 60.500	227402	198
RSDU 100.400-1.5 S OV	191635	243	RSU 60.500	223503	195	RTA 60.500 E3	334001	198
RSDU 100.500-1.5 S OV	191642	243	RSU 60.500 F	224708	195	RTA 60.500 F	536801	198
RSDU 100.600-1.5 S OV	191659	243	RSU 60.600	223701	195	RTA 60.600	227501	198
RSDU 110.100-1.5 S OV	191734	247	RSU 60.600 F	224906	195	RTA 60.600 E3	334100	198
RSDU 110.200-1.5 S OV	191741	247	RSU 85.100	235308	209	RTA 60.600 F	536900	198
RSDU 110.300-1.5 S OV	191758	247	RSU 85.100 F	236503	209	RTA 85.100	239009	211
RSDU 110.400-1.5 S OV	191765	247	RSU 85.200	235506	209	RTA 85.100 F	542604	211
RSDU 110.500-1.5 S OV	191772	247	RSU 85.200 F	236701	209	RTA 85.200	239108	211
RSDU 110.600-1.5 S OV	191789	247	RSU 85.300	235704	209	RTA 85.200 F	542703	211
RSL 400	305445	300	RSU 85.300 F	236909	209	RTA 85.300	239207	211
RSL 400 E3	726202	300	RSU 85.400	235902	209	RTA 85.300 F	542802	211
RSL 400 F	593149	300	RSU 85.400 F	237104	209	RTA 85.400	239306	211
RSL 500	305469	300	RSU 85.500	236107	209	RTA 85.400 F	542901	211
RSL 500 E3	726301	300	RSU 85.500 F	237302	209	RTA 85.500	239405	211
RSL 500 F	424214	300	RSU 85.600	236305	209	RTA 85.500 F	543007	211
RSL 600	305483	300	RSU 85.600 F	237500	209	RTA 85.600	239504	211
RSL 600 E3	726400	300	RSUS 60.100 OV	898237	240	RTA 85.600 F	543106	211
RSL 600 F	593187	300	RSUS 60.200 OV	898251	240	RTADV 100	277100	229
RSLC 100	917655	193	RSUS 60.300 OV	898275	240	RTADV 100 E3	339600	229
RSLC 200	917662	193	RSUV 110-1.5/200 S	148592	222	RTADV 100 F	559008	229
RSLC 300	917686	193	RSUV 60-1.5	861989	240	RTADV 150	277209	229
RSLC 400	870608	208	RSUV 60-1.5/200 S	148615	196	RTADV 150 F	559107	229
RSSKP 100.100 S OV	180677	241	RSUV 85-1.5/200 S	134755	209	RTADV 200	277308	229
RSSKP 100.200 S OV	180684	241	RSUVKS 100-1.5 S	167180	241	RTADV 200 E3	339709	229
RSSKP 100.300 S OV	180691	241	RSUVKS 110-1.5 S	167197	245	RTADV 200 F	559206	229
RSSKP 100.400 S OV	180714	241	RSV 110.100 F	553655	220	RTADV 300	274802	229
RSSKP 100.500 S OV	180721	241	RSV 110.100 S	259069	220	RTADV 300 E3	339808	229
RSSKP 100.600 S OV	180738	241	RSV 110.150 F	553709	220	RTADV 300 F	559404	229
RSSKP 110.100 S OV	180745	245	RSV 110.150 S	259106	220	RTADV 400	277506	229
RSSKP 110.200 S OV	180752	245	RSV 110.200 F	553808	220	RTADV 400 E3	339907	229
RSSKP 110.300 S OV	180769	245	RSV 110.200 S	259205	220	RTADV 400 F	559503	229
RSSKP 110.400 S OV	180776	245	RSV 110.300 F	553907	220	RTADV 500	277605	229
RSSKP 110.500 S OV	180783	245	RSV 110.300 S	259304	220	RTADV 500 E3	340002	229
RSSKP 110.600 S OV	180790	245	RSV 110.400 F	554003	220	RTADV 500 F	559602	229



model no.	EAN code	page	model no.	EAN code	page	model no.	EAN code	page
RTADV 600	277803	229	RTS 110.300	254408	225	RTV 110 E2	251162	312
RTADV 600 E3	340101	229	RTS 110.300 F	550203	225	RTV 50 E2	224999	160
RTADV 600 F	559800	229	RTS 110.400	254507	225	RTV 50 E2	224999	185
RTADVRS 100-2.0 S	133093	249	RTS 110.400 F	550302	225	RTV 60 E2	225149	172
RTADVRS 200-2.0 S	133109	249	RTS 110.500	254606	225	RTV 60 E2	225149	197
RTADVRS 300-2.0 S	133116	249	RTS 110.500 F	550401	225	RTV 85 E2	237753	210
RTADVRS 400-2.0 S	133123	249	RTS 110.600	135769	225	RTV 85 E2	237753	265
RTADVRS 500-2.0 S	133130	249	RTS 110.600 F	133550	225	RTV 85 E2	237753	291
RTADVRS 600-2.0 S	133147	249	RTS 60.100	228805	199	RTV 85 E2	237753	306
RTAK 50.050	210701	187	RTS 60.100 F	538003	199	RV 110.100	273607	221
RTAK 50.100	210909	187	RTS 60.150	228904	199	RV 110.100 E3	920303	221
RTAKDV 100	274307	187	RTS 60.150 F	538058	199	RV 110.100 F	553105	221
RTAKDV 50	276905	187	RTS 60.200	229000	199	RV 110.150 F	553150	221
RTAS 100.100 S	129522	243	RTS 60.200 F	538102	199	RV 110.200	273706	221
RTAS 100.200 S	129539	243	RTS 60.300	229208	199	RV 110.200 E3	920310	221
RTAS 100.300 S	129546	243	RTS 60.300 F	538201	199	RV 110.200 F	553204	221
RTAS 100.400 S	129553	243	RTS 60.400	229307	199	RV 110.300	273805	221
RTAS 100.500 S	129560	243	RTS 60.400 F	538300	199	RV 110.300 E3	920327	221
RTAS 100.600 S	129577	243	RTS 60.500	229406	199	RV 110.300 F	553303	221
RTAS 110.100	862801	247	RTS 60.500 F	538409	199	RV 110.400	273904	221
RTAS 110.200	862825	247	RTS 60.600	229505	199	RV 110.400 E3	920334	221
RTAS 110.300	862849	247	RTS 60.600 F	538508	199	RV 110.400 F	553402	221
RTAS 110.400	862856	247	RTS 85.100	240609	212	RV 110.500	274000	221
RTAS 110.500	862863	247	RTS 85.100 F	544004	212	RV 110.500 E3	920341	221
RTAS 110.600	862887	247	RTS 85.200	240708	212	RV 110.500 F	553501	221
RTL 110.150	793815	228	RTS 85.200 F	544103	212	RV 110.600	274123	221
RTL 110.200	793822	228	RTS 85.300	240807	212	RV 110.600 E3	149858	221
RTL 110.300	793846	228	RTS 85.300 F	544202	212	RV 110.600 F	553624	221
RTL 110.400	793860	228	RTS 85.400	240906	212	RV 60.100	271702	196
RTL 110.500	793884	228	RTS 85.400 F	544301	212	RV 60.100 E3	336159	196
RTL 110.600	140435	228	RTS 85.500	241002	212	RV 60.100 F	540808	196
RTL 60.100	793204	202	RTS 85.500 F	544400	212	RV 60.150	271801	196
RTL 60.150	793211	202	RTS 85.600	241101	212	RV 60.200	271900	196
RTL 60.200	793228	202	RTS 85.600 F	544509	212	RV 60.200 E3	920259	196
RTL 60.300	793242	202	RTSDV 100	277902	231	RV 60.200 F	540907	196
RTL 60.400	793266	202	RTSDV 100 F	560806	231	RV 60.300	272105	196
RTL 60.500	793280	202	RTSDV 150	278008	231	RV 60.300 E3	920266	196
RTL 60.600	793303	202	RTSDV 150 F	560905	231	RV 60.300 F	541003	196
RTL 85.100	793501	215	RTSDV 200	274703	231	RV 60.400	272204	196
RTL 85.200	793525	215	RTSDV 200 F	561001	231	RV 60.400 E3	920273	196
RTL 85.300	793549	215	RTSDV 300	278206	231	RV 60.400 F	541102	196
RTL 85.400	793563	215	RTSDV 300 F	561209	231	RV 60.500	272303	196
RTL 85.500	793587	215	RTSDV 400	278305	231	RV 60.500 E3	920280	196
RTL 85.600	793600	215	RTSDV 400 F	561308	231	RV 60.500 F	541201	196
RTPH 50	231973	197	RTSDV 500	278404	231	RV 60.600	272402	196
RTPH 50	231973	210	RTSDV 500 F	561407	231	RV 60.600 E3	920297	196
RTPH 50	231973	222	RTSDV 600	278602	231	RV 60.600 F	541300	196
RTPH 50 M6	961955	197	RTSDV 600 F	561605	231	RV 85.100	272501	209
RTPH 50 M6	961955	210	RTSDVRS 100-2.0 S	133031	250	RV 85.100 F	546800	209
RTPH 50 M6	961955	223	RTSDVRS 200-2.0 S	133048	250	RV 85.200	272600	209
RTQ 110.100	793921	228	RTSDVRS 300-2.0 S	133055	250	RV 85.200 F	546909	209
RTQ 110.150	793938	228	RTSDVRS 400-2.0 S	133062	250	RV 85.300	272709	209
RTQ 110.200	793945	228	RTSDVRS 500-2.0 S	133079	250	RV 85.300 F	547005	209
RTQ 110.300	793969	228	RTSDVRS 600-2.0 S	133086	250	RV 85.400	272808	209
RTQ 110.400	793983	228	RTSK 50.050	211104	187	RV 85.400 F	547104	209
RTQ 110.500	794003	228	RTSK 50.100	211302	187	RV 85.500	272907	209
RTQ 110.600	140398	228	RTSKDV 100	274604	188	RV 85.500 F	547203	209
RTQ 60.100	793327	202	RTSKDV 50	274406	188	RV 85.600	273003	209
RTQ 60.150	793334	202	RTSQF 100-1.5/1000 S	134922	242	RV 85.600 F	547302	209
RTQ 60.200	793341	202	RTSQF 110-1.5/1000 S	134946	246	RVC 60	870523	193
RTQ 60.300	793365	202	RTSS 100.100 S	129720	243	RVC 85	937158	207
RTQ 60.400	793389	202	RTSS 100.200 S	129737	243	RVV 110 E3	732005	221
RTQ 60.500	793402	202	RTSS 100.300 S	129744	243	RVV 110.100	259663	221
RTQ 60.600	793426	202	RTSS 100.400 S	129751	243	RVV 110.100 F	554058	221
RTQ 85.100	793624	215	RTSS 100.500 S	129768	243	RVV 110.150	259700	221
RTQ 85.200	793648	215	RTSS 100.600 S	129775	243	RVV 110.150 F	554102	221
RTQ 85.300	793662	215	RTSS 110.100	862900	247	RVV 110.200	259809	221
RTQ 85.400	793686	215	RTSS 110.200	862924	247	RVV 110.200 F	554201	221
RTQ 85.500	793709	215	RTSS 110.300	862948	247	RVV 110.300	259908	221
RTQ 85.600	793723	215	RTSS 110.400	862962	247	RVV 110.300 F	554300	221
RTS 110.100	254200	225	RTSS 110.500	862979	247	RVV 110.400	260003	221
RTS 110.100 F	550005	225	RTSS 110.600	862993	247	RVV 110.400 F	554409	221
RTS 110.150	254255	225	RTV 110 E2	251162	160	RVV 110.500	260041	221
RTS 110.150 F	550050	225	RTV 110 E2	251162	172	RVV 110.500 F	554447	221
RTS 110.200	254309	225	RTV 110 E2	251162	222	RVV 110.600	150144	221
RTS 110.200 F	550104	225	RTV 110 E2	251162	297	RVV 110.600 F	150151	221

LIST OF ITEMS

model no.	EAN code	page	model no.	EAN code	page	model no.	EAN code	page
RVV 50	258604	186	SKM 8X16 E3	343904	141	STVDP 30.43 S	055418	281
RVV 50	258604	196	SKM 8X16 V	207107	141	STVFA 200 F	071937	281
RVV 50 E3	335404	186	SKSP 70	940455	128	STVFA 200 S	055241	281
RVV 50 E3	335404	196	SKSP 70	940455	266	STVFA 300 F	071944	281
RVV 50 F	258505	186	SKSP 70	940455	320	STVFA 300 S	055258	281
RVV 50 F	258505	196	SKU 4530	165575	100	STVFA 400 F	071951	281
RW 100-1.5 S	180219	241	SKU 5050	188390	104	STVFA 400 S	055265	281
RW 100-2.0 S	180189	241	SKU 6040	912162	111	STVFA 500 F	071968	281
RW 110	251001	160	SKU 6040	912162	277	STVFA 500 S	055272	281
RW 110	251001	222	SKWHM 105	939350	294	STVFA 600 F	071975	281
RW 110	251001	297	SKWHM 105	939350	309	STVFA 600 S	055289	281
RW 110	251001	312	SKWHM 150	072699	300	STVVA 200 F	072057	281
RW 110 E3	333509	172	SKWHM 150	072699	315	STVVA 200 S	055357	281
RW 110 E3	333509	222	SMF M10 1661 V	187164	141	STVVA 300 F	072064	281
RW 110 E3	333509	297	SMF M6 1661 V	047192	141	STVVA 300 S	055364	281
RW 110 E3	333509	312	SMF M8 1661 V	187157	141	STVVA 400 F	072071	281
RW 110 F	251100	222	SMU 10	203703	144	STVVA 400 S	055371	281
RW 110 F	251100	297	SMU 10 E3	344260	144	STVVA 500 F	072088	281
RW 110 F	251100	312	SMU 12	344406	144	STVVA 500 S	055388	281
RW 110-1.5 S	180165	245	SMU 12 E3	344284	144	STVVA 600 F	072095	281
RW 110-2.0 S	180141	245	SMU 8	203604	144	STVVA 600 S	055395	281
RW 50	224951	185	SPC 86/1000	326006	279	STWBKS 100/110-1.5 S	204618	248
RW 50 E3	333356	185	SPC 86/1100	326105	279	SVL 41 F	892501	132
RW 50 F	938551	185	SPC 86/1200	326204	279	SWS 41 F	223510	133
RW 60	225002	160	SPC 86/200	325528	279	TPH 60	806003	330
RW 60	225002	196	SPC 86/300	325542	279	TPH 80	459278	330
RW 60 E3	333400	172	SPC 86/400	325566	279	TPS 30	459223	331
RW 60 E3	333400	196	SPC 86/500	325580	279	TPS 50	459247	331
RW 60 F	225101	196	SPC 86/600	325603	279	TPS 70	459261	331
RW 60-2.0 S	180127	240	SPC 86/700	325702	279	TPS 90	720309	331
RW 85	237609	209	SPC 86/800	325801	279	TPSX 90 E3	879502	339
RW 85	237609	265	SPC 86/900	325900	279	TR 86 S	162703	252
RW 85	237609	291	SPCKL 86/1000 F	924981	276	TRV 40	891795	138
RW 85	237609	306	SPCKL 86/1100 F	925001	276	TRV 40 E3	892150	138
RW 85 E3	333424	291	SPCKL 86/1200 F	925025	276	TV 40	160105	253
RW 85 E3	333424	306	SPCKL 86/200 F	924820	276	TZK 86-96 S	073924	139
RW 85 F	237708	209	SPCKL 86/300 F	924844	276	U 5050/3000 F	859306	105
RW 85 F	237708	291	SPCKL 86/400 F	924868	276	U 5050/6000 F	859320	105
RW 85 F	237708	306	SPCKL 86/500 F	924882	276	U 6040/3000 E3	892105	111
RZP 100/100 S	114153	254	SPCKL 86/600 F	924905	276	U 6040/3000 F	891740	111
RZP 100/200 S	114146	254	SPCKL 86/700 F	924929	276	U 6040/3000 F	891740	277
RZP 100/300 S	121328	254	SPCKL 86/800 F	924943	276	U 6040/6000 E3	892129	111
RZP 100/3000 S	124749	254	SPCKL 86/900 F	924967	276	U 6040/6000 F	891764	111
RZP 100/400 S	121335	254	SPKGM 25 F	934959	136	U 6040/6000 F	891764	277
RZP 100/500 S	121342	254	SPKM 25 F	931040	135	UGM 10	209101	143
RZP 100/600 S	127658	254	SPPGM 30 F	930944	113	UGM 10 E3	936854	143
RZP 50/100	191833	253	SPPGM 30 F	930944	121	UGM 10 F	071661	143
RZP 50/200	847907	253	SPPGM 30 F	930944	137	UGM 12 E3	072385	143
RZP 50/300	847921	253	SPPM 30 F	930937	112	UGM 12 F	071678	143
RZP 50/400	847945	253	SPPM 30 F	930937	121	UGM 12 V	072378	143
RZP 50/500	847969	253	SPPM 30 F	930937	136	UGM 6	208906	143
RZP 50/600	847983	253	SSV 4141 F	898541	132	UGM 6 E3	927258	143
RZPBL 25.90	861583	254	STIC 86/1006	323906	278	UGM 6 F	071685	143
SBB 41 F	898527	133	STIC 86/1106	324002	278	UGM 8	209002	143
SGP 41 F	224142	132	STIC 86/1206	324101	278	UGM 8	209002	256
SK 10X25 F	068319	141	STIC 86/206	873203	278	UGM 8 E3	931248	143
SK 12X25 F	223558	141	STIC 86/306	873227	278	UGM 8 E3	931248	256
SK 6X20 F	223565	141	STIC 86/406	873241	278	UGM 8 F	209057	143
SK 8X25 F	127702	141	STIC 86/506	873265	278	US M10 F	223619	143
SKC 86	933105	130	STIC 86/606	323500	278	US M12 F	216093	143
SKC 88/96	926800	131	STIC 86/706	323609	278	US M6 F	223626	143
SKCED 96	079827	132	STIC 86/806	323708	278	US M8 F	223633	143
SKI 80	912605	118	STIC 86/906	323807	278	VB 50	199303	105
SKI 80	912605	280	STS 41 F	223534	133	VB 6040	891788	112
SKK 100	918423	267	STUC 60/1005 F	924769	276	VB 6040	891788	277
SKKSA 100	227495	242	STUC 60/1105 F	924783	276	VB 6040 E3	892143	112
SKKSA 110	227488	246	STUC 60/1205 F	924806	276	VBASB 106.7-2.0/3000 S	115129	256
SKKSA 60	227471	240	STUC 60/205 F	924608	276	VBASB 85-1.5/3000 S	138432	254
SKM 10X25 E3	344000	141	STUC 60/305 F	924622	276	VBASB 92.8-1.5/3000 S	132164	255
SKM 10X25 V	207305	141	STUC 60/405 F	924646	276	VBASB 95-1.5/3000 S	152971	254
SKM 10X50 V	207503	141	STUC 60/505 F	924660	276	VBI 80	199501	119
SKM 10X70 V	207541	141	STUC 60/605 F	924684	276	VBI 80	199501	279
SKM 12X50 F	071531	95	STUC 60/705 F	924707	276	VBIQ 80/140	938506	119
SKM 12X50 V	064731	141	STUC 60/805 F	924721	276	VBSM 10	345601	144
SKM 12X70 F	071548	95	STUC 60/905 F	924745	276	VBSM 12	345700	144
SKM 12X70 V	207565	141	STVDP 30.43 F	071920	281	VBSM 8	345588	144



model no.	EAN code	page	model no.	EAN code	page	model no.	EAN code	page
VP 50.50	209200	138	WLAB 300	899746	315	WRLM 150.400	893324	296
WA 100	189809	96	WLAB 300 E3	900022	315	WRLM 150.400 F	893379	296
WA 150	189908	96	WLAB 300 F	900237	315	WRLM 150.500	893331	296
WA 200	190003	96	WLAB 400	899753	315	WRLM 150.500 F	893386	296
WA 250	190102	96	WLAB 400 E3	900039	315	WRLM 150.600	893348	296
WA 300	190201	96	WLAB 400 F	900244	315	WRLM 150.600 F	893393	296
WA 400	190300	96	WLAB 500	899760	315	WRTAR 105.200	949106	292
WA 500	190409	96	WLAB 500 E3	900046	315	WRTAR 105.200 E3	950966	292
WA 600	190508	96	WLAB 500 F	900251	315	WRTAR 105.200 F	950034	292
WAER 105	949250	292	WLAB 600	899777	315	WRTAR 105.300	949113	292
WAER 105	949250	307	WLAB 600 E3	900053	315	WRTAR 105.300 E3	950973	292
WAER 105 E3	951062	292	WLAB 600 F	900268	315	WRTAR 105.300 F	950041	292
WAER 105 E3	951062	307	WRBR 105.200	949281	293	WRTAR 105.400	949120	292
WAER 105 F	950188	292	WRBR 105.200E3	951086	293	WRTAR 105.400 E3	950980	292
WAER 105 F	950188	307	WRBR 105.200 F	950218	293	WRTAR 105.400 F	950058	292
WAER 150	949267	298	WRBR 105.300	949298	293	WRTAR 105.500	949137	292
WAER 150	949267	313	WRBR 105.300E3	951093	293	WRTAR 105.500 E3	950997	292
WAER 150 E3	951079	298	WRBR 105.300 F	950225	293	WRTAR 105.500 F	950065	292
WAER 150 E3	951079	313	WRBR 105.400	949304	293	WRTAR 105.600	949144	292
WAER 150 F	950195	298	WRBR 105.400E3	951109	293	WRTAR 105.600 E3	951000	292
WAER 150 F	950195	313	WRBR 105.400 F	950232	293	WRTAR 105.600 F	950072	292
WBKS 130 E3	940547	301	WRBR 105.500	949311	293	WRTAR 150.200	949151	298
W-BL 20.65	872121	146	WRBR 105.500E3	951116	293	WRTAR 150.200 E3	951017	298
W-BL 30.65	872145	146	WRBR 105.500 F	950249	293	WRTAR 150.200 F	950089	298
WBRDV 200	966400	317	WRBR 105.600	949328	293	WRTAR 150.300	949168	298
WBRDV 200 E3	966509	317	WRBR 105.600E3	951123	293	WRTAR 150.300 E3	951024	298
WBRDV 200 F	966455	317	WRBR 105.600 F	950256	293	WRTAR 150.300 F	950096	298
WBRDV 300	966417	317	WRBR 150.200	949335	298	WRTAR 150.400	949175	298
WBRDV 300 E3	966516	317	WRBR 150.200 E3	951130	298	WRTAR 150.400 E3	951031	298
WBRDV 300 F	966462	317	WRBR 150.200 F	950263	298	WRTAR 150.400 F	950102	298
WBRDV 400	966424	317	WRBR 150.300	949342	298	WRTAR 150.500	949182	298
WBRDV 400 E3	966523	317	WRBR 150.300 E3	951147	298	WRTAR 150.500 E3	951048	298
WBRDV 400 F	966479	317	WRBR 150.300 F	950270	298	WRTAR 150.500 F	950119	298
WBRDV 450	082759	317	WRBR 150.400	949359	298	WRTAR 150.600	949199	298
WBRDV 450 F	082766	317	WRBR 150.400 E3	951154	298	WRTAR 150.600 E3	951055	298
WBRDV 500	966431	317	WRBR 150.400 F	950287	298	WRTAR 150.600 F	950126	298
WBRDV 500 E3	966530	317	WRBR 150.500	949366	298	WRTR 105.200	949434	293
WBRDV 500 F	966486	317	WRBR 150.500 E3	951161	298	WRTR 105.200 E3	951185	293
WBRDV 600	966448	317	WRBR 150.500 F	950294	298	WRTR 105.200 F	950362	293
WBRDV 600 E3	966547	317	WRBR 150.600	949373	298	WRTR 105.300	949441	293
WBRDV 600 F	966493	317	WRBR 150.600 E3	951178	298	WRTR 105.300 E3	951192	293
WBRDV 750 S	236640	317	WRBR 150.600 F	950300	298	WRTR 105.300 F	950379	293
WBRDV 900	149728	317	WRL 105.200	310708	290	WRTR 105.400	949458	293
WDRS 20	310609	319	WRL 105.200 E3	724802	290	WRTR 105.400 E3	951208	293
WDRS 20 E3	809004	319	WRL 105.200 F	587803	290	WRTR 105.400 F	950386	293
WDRS 20 F	596508	319	WRL 105.300	310807	290	WRTR 105.500	949465	293
WDV 200	309801	317	WRL 105.300 E3	724826	290	WRTR 105.500 E3	951215	293
WDV 200 E3	806508	317	WRL 105.300 F	587902	290	WRTR 105.500 F	950393	293
WDV 200 F	596003	317	WRL 105.400	310906	290	WRTR 105.600	949472	293
WDV 300	309900	317	WRL 105.400 E3	724840	290	WRTR 105.600 E3	951222	293
WDV 300 E3	806522	317	WRL 105.400 F	588008	290	WRTR 105.600 F	950409	293
WDV 300 F	596102	317	WRL 105.500	311002	290	WRTR 150.200	949489	299
WDV 400	310005	317	WRL 105.500 E3	724864	290	WRTR 150.200 E3	951239	299
WDV 400 E3	806546	317	WRL 105.500 F	588107	290	WRTR 150.200 F	950416	299
WDV 400 F	596201	317	WRL 105.600	311101	290	WRTR 150.300	949496	299
WDV 450	941940	317	WRL 105.600 E3	724888	290	WRTR 150.300 E3	951246	299
WDV 450 F	942886	317	WRL 105.600 F	588206	290	WRTR 150.300 F	950423	299
WDV 500	310104	317	WRL 150.200	313204	295	WRTR 150.400	949502	299
WDV 500 E3	806560	317	WRL 150.200 E3	725502	295	WRTR 150.400 E3	951253	299
WDV 500 F	596300	317	WRL 150.200 F	590506	295	WRTR 150.400 F	950430	299
WDV 600	310203	317	WRL 150.300	313303	295	WRTR 150.500	949519	299
WDV 600 E3	806584	317	WRL 150.300 E3	725526	295	WRTR 150.500 E3	951260	299
WDV 600 F	596409	317	WRL 150.300 F	590605	295	WRTR 150.500 F	950447	299
WDV 750	941933	317	WRL 150.400	313402	295	WRTR 150.600	949526	299
WDV 900	941926	317	WRL 150.400 E3	725540	295	WRTR 150.600 E3	951277	299
WHAS 105 E3	210640	294	WRL 150.400 F	590704	295	WRTR 150.600 F	950454	299
WHAS 105 E3	210640	309	WRL 150.500	313501	295	WRU 105.200	311200	290
WHAS 105 S	210657	294	WRL 150.500 E3	725564	295	WRU 105.200 F	588305	290
WHAS 105 S	210657	309	WRL 150.500 F	590803	295	WRU 105.300	311309	290
WHAS 150 E3	210664	300	WRL 150.600	313600	295	WRU 105.300 F	588404	290
WHAS 150 E3	210664	315	WRL 150.600 E3	725588	295	WRU 105.400	311408	290
WHAS 150 S	210671	300	WRL 150.600 F	590902	295	WRU 105.400 F	588503	290
WHAS 150 S	210671	315	WRLM 150.200	893300	296	WRU 105.500	311507	290
WLAB 200	899739	315	WRLM 150.200 F	893355	296	WRU 105.500 F	588602	290
WLAB 200 E3	900015	315	WRLM 150.300	893317	296	WRU 105.600	311606	290
WLAB 200 F	900220	315	WRLM 150.300 F	893362	296	WRU 105.600 F	588701	290

model no.	EAN code	page	model no.	EAN code	page	model no.	EAN code	page
WSV 150.500	301706	311	WTARDV 450	082773	318	WTRDV 600 F	966646	318
WSV 150.500 E3	340149	296	WTARDV 450 F	082797	318	WTRDV 750 S	236664	318
WSV 150.500 E3	340149	311	WTARDV 500	966738	318	WWA 100	194759	138
WSV 150.500 F	301805	296	WTARDV 500 E3	966837	318	WWA 100	194759	268
WSV 150.500 F	301805	311	WTARDV 500 F	966783	318	WWA 100	194759	278
WSWV 105.390	305377	291	WTARDV 600	966745	318	WWA 100	194759	316
WSWV 105.390	305377	306	WTARDV 600 E3	966844	318	WWA 100 E3	344345	138
WSWV 105.390 E3	725458	291	WTARDV 600 F	966790	318	WWA 100 E3	344345	316
WSWV 105.390 E3	725458	306	WTARDV 750 S	236657	318	WWI 80	193004	120
WSWV 105.390 F	590452	291	WTARDV 900	149865	318	WWI 80	193004	280
WSWV 105.390 F	590452	306	WTRDV 200	966554	318	WWU 150	194407	137
WSWV 150	305407	297	WTRDV 200 E3	966653	318	WWU 150	194407	277
WSWV 150	305407	312	WTRDV 200 F	966608	318	WWU 150	194407	316
WSWV 150 E3	726103	297	WTRDV 300	966561	318	WWU 150/8	194506	137
WSWV 150 E3	726103	312	WTRDV 300 E3	966660	318	WWU 150/8	194506	268
WSWV 150 F	593101	297	WTRDV 300 F	966615	318	WWU 150/8	194506	316
WSWV 150 F	593101	312	WTRDV 400	966578	318	WWU 150/8 E3	344307	137
WTARDV 200	966707	318	WTRDV 400 E3	966677	318	WWU 150/8 E3	344307	316
WTARDV 200 E3	966806	318	WTRDV 400 F	966622	318	ZC 100 S	192076	164
WTARDV 200 F	966752	318	WTRDV 450	082810	318	ZC 150 S	235049	164
WTARDV 300	966714	318	WTRDV 450 F	082827	318	ZC 200 S	192083	164
WTARDV 300 E3	966813	318	WTRDV 500	966585	318	ZC 300 S	192090	164
WTARDV 300 F	966769	318	WTRDV 500 E3	966684	318	ZS M10	208708	144
WTARDV 400	966721	318	WTRDV 500 F	966639	318	ZS M12	208807	144
WTARDV 400 E3	966820	318	WTRDV 600	966592	318	ZS M6	208500	144
WTARDV 400 F	966776	318	WTRDV 600 E3	966691	318	ZS M8	208609	144

CERTIFICATE OF COMPLIANCE

Certificate Number 20191104-E233344
Report Reference E233344-20120712
Issue Date 2019-NOVEMBER-04

Issued to: Niedax GmbH & Co. KG
Asbacher Strasse 141
53545 Linz/Rhein GERMANY

This certificate confirms that representative samples of CABLE TRAYS, METAL
See Addendum

Have been investigated by UL in accordance with the Standard(s) indicated on this Certificate.

Standard(s) for Safety: Sections 392.60(A) and 392.60(B) of NFPA 70 NATIONAL ELECTRICAL CODE WITH AMD 1 - 5
NEMA VE1 METAL CABLE TRAY SYSTEMS
CSA C22.2 NO. 126.1, METAL CABLE TRAY SYSTEMS

Additional Information: See the UL Online Certifications Directory at <https://iq.ulprospector.com> for additional information.

This *Certificate of Compliance* does not provide authorization to apply the UL Mark. Only the UL Follow-Up Services Procedure provides authorization to apply the UL Mark.

Only those products bearing the UL Mark should be considered as being UL Certified and covered under UL's Follow-Up Services.

Look for the UL Certification Mark on the product.



Bruce Mahrenholz, Director North American Certification Program
UL LLC

Any information and documentation involving UL Mark services are provided on behalf of UL LLC (UL) or any authorized licensee of UL. For questions, please contact a local UL Customer Service Representative at <http://ul.com/aboutul/locations/>



Electronically published by ABS Houston.
Reference T2362278, dated 01-MAR-2023.



CERTIFICATE NUMBER	23-2362278-PDA
EFFECTIVE DATE	01-Mar-2023
EXPIRY DATE	29-Feb-2028
ABS TECHNICAL OFFICE	Houston ESD - Piping

CERTIFICATE OF Product Design Assessment

This is to certify that a representative of this Bureau did, at the request of

NIEDAX GMBH & CO. KG

located at

ASBACHER STR. 141, , D-53545 LINZ AM RHEIN, Germany

assess design plans and data for the below listed product. This assessment is a representation by the Bureau as to the degree of compliance the design exhibits with applicable sections of the Rules. This assessment does not waive unit certification or classification procedures required by ABS Rules for products to be installed in ABS classed vessels or facilities. This certificate, by itself, does not reflect that the product is Type Approved. The scope and limitations of this assessment are detailed on the pages attached to this certificate.

Product: Cable Supports
Model: KLMUX 40, KLMUL 40, KLMUL(X) 40, KLMULL(X) 40, KLMZL(X) 40, KLMZLL(X) 40, RSX 60, RSX 85, RSX 110, RLX 60, RLX 85, RLX 110, RLUX 60, RLUX 85, RLUX 110, RSUX 60, RSUX 85, RSUX 110, ...
Endorsements:
Tier: 2 - PDA Issued

This Product Design Assessment (PDA) Certificate remains valid until 29/Feb/2028 or until the Rules and/or Standards used in the assessment are revised or until there is a design modification warranting design reassessment (whichever occurs first).

Acceptance of product is limited to the "Intended Service" details prescribed in the certificate and as per applicable Rules and Standards.

This Certificate is valid for installation of the listed product on ABS units which exist or are under contract for construction on or previous to the effective date of the ABS Rules and standards applied at the time of PDA issuance. Use of the Product for non-ABS units is subject to agreement between the manufacturer and intended client.

American Bureau Of Shipping

John Vincent Ulep
John Vincent Bog-Acon Ulep, Engineer/Consultant

NOTE: This certificate evidences compliance with one or more of the Rules, Guides, standards or other criteria of ABS or a statutory, industrial or manufacturer's standards. It is issued solely for the use of ABS, its committees, its clients or other authorized entities. Any significant changes to the aforementioned product without approval from ABS will result in this certificate becoming null and void. This certificate is governed by ABS Rules 1-1-A3/5.9 Terms and Conditions of the Request for Product Type Approval and Agreement (2010)



Commission Electrotechnique Internationale
International Electrotechnical Commission
Международная Электротехническая Комиссия

DIN EN IEC 61537:2019-11

is the Global Standard for Cable Tray and Cable Ladder Systems for Cable Management and specifies requirements and tests for cable tray systems (such as all metal cable trays including wire mesh cable tray and cable ladders) for the support, accommodation of cables and possibly other electrical equipment in electrical and/or communications systems installations.

All Niedax Support Systems are manufactured and tested in accordance with DIN EN IEC 61537 by Niedax GmbH & Co. KG in Linz/Germany. The safe working load as defined by the standard is the lowest value of either the load creating a deflection of $L/20$ at the end or the breaking load divided by 1.7 if the deflection is not reached.

All Niedax Cable Tray and Cable Ladder Systems are manufactured and tested in accordance with DIN EN IEC 61537 by Niedax GmbH & Co. KG in Linz/Germany.

Testing is done with an equally balanced load and a splice located in the middle of the span. The safe working load is the smallest value of either the load creating a deflection of $1/100^{\text{th}}$ of the span or the breaking load divided by 1.7. While the standard is requiring just $1/100^{\text{th}}$, Niedax is even more demanding and has reduced this figure to $1/200^{\text{th}}$.

NOTES

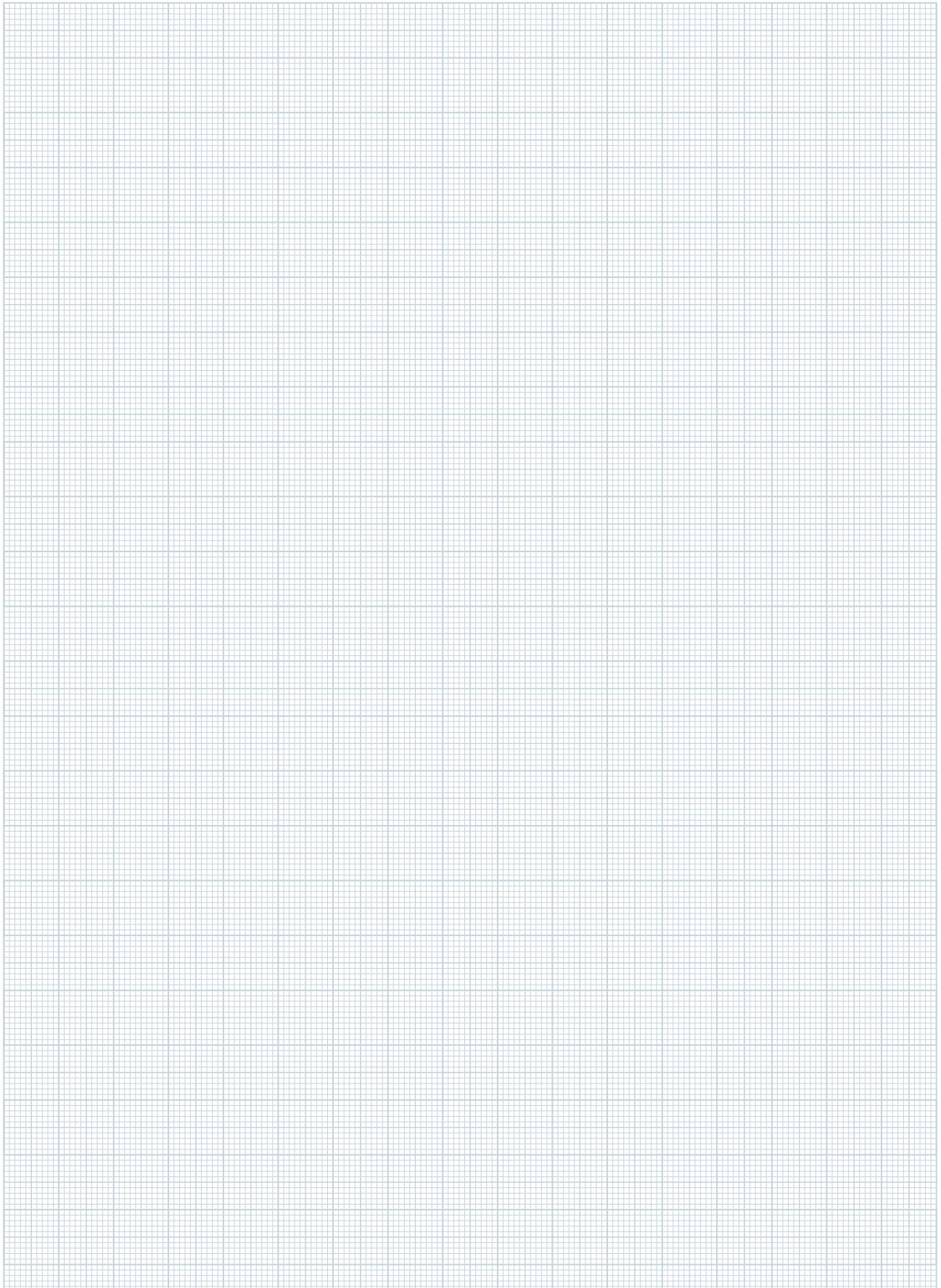

CABLE TRAY SYSTEM



GENERAL INFORMATION

- Material Handling
- Corrosion Protection
- Finishes
- Installation Instructions

This chapter provides some very useful technical information about cable trays. Please study carefully.

For further information please contact us. Simply call us on +1 614 921 8469 or send an e-mail to sales@niedaxusa.com.



WARNING!

Cable tray should not be used as a walkway, ladder, or support for people; cable tray is a mechanical support system for cables and raceways. Using cable trays as a walkway can result in personal injury and also cause damage to the cable tray system and installed cables.

Hazardous voltages in electrical equipment can cause severe personal injury or death. Safety related work practices, as described in NFPA 70E, Part 11 or VDE 0100, should be followed at all times.

The overall performance of a cable tray wiring system is dependent upon proper installation, including supports and cables.

Non-adherence to installation and maintenance guidelines may lead to personal injury as well as damage to property.

Installation and proper maintenance of cable tray wiring systems should be performed only by qualified personnel. For the purposes of this guideline, a qualified installer is one who is familiar with electrical construction. In addition, the person should be:

Trained and authorized to test, energize, clear, ground, tag, and lockout circuits in accordance with established safety practices.

Trained in the proper care and use of protective equipment such as insulated rubber gloves, hardhats, safety glasses or face shields, dust masks and flash resistant clothing in accordance with established safety practices and / or local building codes.

RECEIVING AND UNLOADING

Cable tray is generally bundled and shipped on extended pallets weighing up to 5.500 pounds. Please make sure that proper unloading equipment (e.g. forklift with extended forks) is available.

Inventory all items immediately after unloading and note on the bill of lading any shortage or shipping damage.

STORAGE

Aluminum, Fiberglass, Stainless Steel and /or other non-metallic cable tray can be stored outside without protective covering. Tray should be loosely stacked, elevated off the ground, and ventilated to prevent storage stain. If appearance is important, cable tray should be stored indoors to prevent water or other environmental factors from staining or adhering to cable tray.

Hot dipped galvanized after fabrication (H.D.G.A.F.), mill galvanized or electro-galvanized cable tray must be protected or stored in a well ventilated, dry location.

Bare steel cable tray should receive a protective coating as soon as possible to prevent surface rust.

PVC or painted cable tray should be protected and stored indoors if possible. Cable tray must be protected from scratching and marring of finish.

SPAN/LOAD CLASS DESIGNATION - USA

NEMA CLASS	SUPPORT SPAN		MAX. LOAD	
	m	ft.	kg/m	lb./ft.
5 AA	1,5	5	37	25
5 A	1,5	5	74	50
8 AA	2,4	8	37	25
8 A	2,4	8	74	50
8 B	2,4	8	112	75
8 C	2,4	8	149	100
10 AA	3,0	10	37	25
10 A	3,0	10	74	50
12 AA	3,7	12	37	25
12 A	3,7	12	74	50
12 B	3,7	12	112	75
12 C	3,7	12	149	100
20 AA	6,0	20	37	25
20 A	6,0	20	74	50
20 B	6,0	20	112	75
20 C	6,0	20	149	100

SPAN/LOAD CLASS DESIGNATION - CANADA

NEMA CLASS	DESIGN LOAD		SUPPORT SPACING	
	kg/m	lb./ft.	m	ft.
A	99	67	1,5	5
A	37	25	3,0	10
C	259	174	1,5	5
C	97	65	3,0	10
D	179	120	3,0	10
D	67	45	6,0	20
E	299	200	3,0	10
E	112	75	6,0	20

The designer of the installation should take into consideration the effects of snow, wind and other environmental forces where necessary.

Material and Finish

AVAILABLE STANDARDS

STEEL	
Type	ASTM A-1011 CS Type B (14 Gauge Plain Steel)
	ASTM A-1008 CS Type B (16 and 18 Gauge Plain Steel)
	ASTM A-510 Gr. 1008 (Plain Wire)
	ASTM A-653 G90 (Pre-Galvanized Steel)
Characteristics	Various Finishes (ASTM B-633, ASTM A-653, ASTM A-123), Good Electric Shielding, Low Thermal Expansion, Limited Deflection

STAINLESS STEEL	
Type	AISI Type 304 (1.4301) and AISI Type 316/316L (1.4571/1.4404)
Characteristics	High Corrosion Resistance, Wide Operable Temperature Range, Low Thermal Expansion, Limited Deflection

STEEL

Steel cable trays are fabricated from continuous roll-formed structural quality steel. By roll-forming steel, the mechanical properties are increased allowing the use of a lighter gauge steel to carry the required load. This reduces the dead weight that must be carried by the supports and makes the system easier to install for the contractor. By using structural quality steel, Niedax assures that the material (steel) will meet the minimum yield and tensile strengths of applicable ASTM standards. All cable tray side rails, rungs and splice plates are numbered for material identification purposes. The corrosion resistance of steel can vary widely, depending on types of coatings and alloy used.

STAINLESS STEEL

Stainless Steel cable trays are fabricated from continuous roll-formed AISI Type 304 and 316 stainless steel. They are non-magnetic and belong to the group called austenitic stainless steels. Like carbon steel, they exhibit increased strength when cold worked by roll-forming or bending. Several important factors make the use of stainless steel imperative. Considerations such as: long term maintenance costs, corrosion resistance, appearance and locations where product contamination is undesirable, are key factors in determining the necessity of Stainless Steel Material. Stainless Steel exhibits stable structural properties such as yield strength and high creep strength at elevated temperatures. Niedax Stainless Steel cable trays are welded using stainless steel welding wire to ensure that each weld exhibits the same corrosion resistant characteristic as the base metal. A detailed study of the corrosive environment is recommended when considering a stainless steel design.

ZINC COATINGS

Zinc protects steel in two ways. First, it acts as a protective coating and secondly, as a sacrificial anode to repair bare areas such as cut edges, scratches, and gouges. The corrosion protection of zinc is directly related to its thickness and the environment. i.e., a .2 mil coating will last twice as long as a .1 mil coating in the same environment. Galvanizing also protects cut and drilled edges.



ELECTROGALVANIZED ZINC

Electrogalvanized Zinc (also known as zinc plated or electroplated) is the process by which a coating of zinc is deposited on the steel by electrolysis from a bath of zinc salts. This finish is standard for cable tray hardware and some accessories for pre-galvanized systems. When exposed to air and moisture, zinc forms a tough, adherent, protective film consisting of a mixture of zinc oxides, hydroxides, and carbonates. This film is in itself a barrier coating which slows subsequent corrosive attack on the zinc. This coating is usually only recommended for indoor use in relatively dry areas, as it provides limited protection (ninety-six hours of protection in salt spray testing per ASTM 8117).

PRE-GALVANIZED ZINC

(Mill galvanized, hot dip mill galvanized or continuous hot dip galvanized)

Pre-Galvanized steel is produced by coating coils of sheet steel with zinc. This process is accomplished by continuously rolling the material through molten zinc at the mills. This procedure is also used to produce mill galvanized and hot dip mill galvanized material. The coils are then slit to size and fabricated by roll forming, shearing, punching, or forming to produce Niedax pre-galvanized cable tray products. The G90 specification calls for a coating of .90 ounces of zinc per square foot of steel. This results in a coating of .45 ounces per square foot on each side of the sheet. This is important when comparing this finish to hot dip galvanized after fabrication. During fabrication, cut edges and welded areas are not normally zinc coated; however, the zinc located near the uncoated metal becomes a sacrificial anode to protect the bare areas within a short period of time.

HOT DIP GALVANIZED AFTER FABRICATION

(Hot dip galvanized or batch hot dip galvanized)

Hot Dip Galvanized After Fabrication cable tray products are fabricated from steel and then completely immersed in a bath of molten zinc. A metallic bond occurs resulting in a zinc coating that completely coats every surface, including edges and welds.

A key advantage of this method is coating thickness. Cable trays that are hot dip galvanized after fabrication have a minimum thickness of 1.50 ounces per square foot on each side, or a total of 3.0 ounces per square foot of steel, according to ASTM A123.

The zinc thickness can be controlled by the amount of time each part is immersed in the molten zinc bath as well as the speed at which it is removed.

The layer of zinc which bonds to the steel provides a dual protection against corrosion. It protects first as an overall barrier coating. If this coating happens to be scratched or gouged, zinc's secondary defense, galvanic action is called upon to protect the steel.

Hot dip galvanized after fabrication is recommended for prolonged outdoor exposure and will protect steel for many years in most outdoor environments as well as in many aggressive industrial environments.

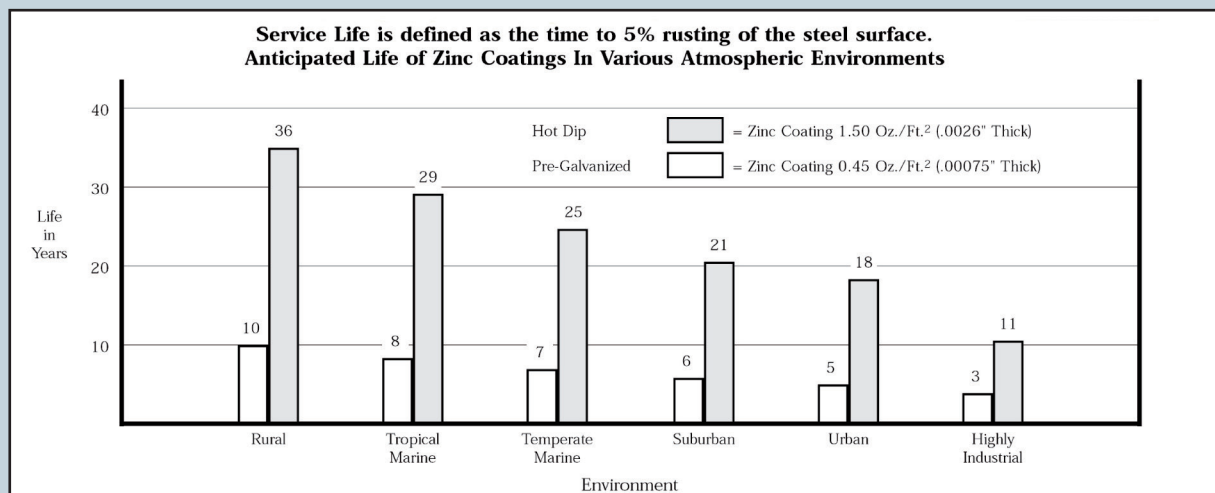

Galvanizing Processes

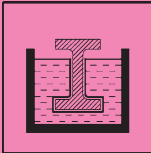
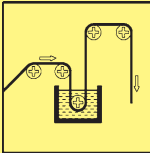
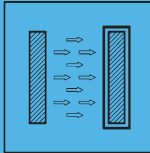
Liquid Dip Process	S	Electrolytic Process
		
Process standard		
Hot Dip Galvanizing (HDG) after fabrication according to DIN EN ISO 1461 (DIN EN ISO 10684 for hardware)	Continuous Strip Galvanization (Sendzimir Process) according to DIN EN 10 346	Electrolytic Galvanizing (Electroplating) according to DIN EN ISO 19598 / DIN EN ISO 2081 (DIN EN ISO 4042 for hardware)
Structure and composition of the coating		
Alloying with the base material	Alloying with the base material	Laminated coating
Usual thickness of the zinc layer		
Depending on the thickness of the material to be galvanized, up to 1.5 mm thickness approx. 45 µm, up to 3 mm thickness approx. 55 µm, up to 6 mm thickness approx. 70 µm	Layer thickness Z 140: 10 µm ± 3 µm Layer thickness Z 275: 20 µm ± 5 µm according to DIN EN 10 346	Approx. 2.5 to 20 µm, in undercuts and recesses (thread flanks) the layer thickness is less than on open surfaces
Special features		
Each component is individually dipped in the liquid zinc bath. The zinc washes over the entire surface. Hollow sections are protected on the in- and outside. Rigid corrosion protection	The corrosion protection layer is applied to the surface by passing the steel as a continuous ribbon through a bath of molten zinc.	The zinc layer is deposited from an aqueous electrolyte by means of DC current. Post-treatment is generally applied to improve the protective effect. Decorative visual appearance, smooth surface with no edges and burrs. 3
Distinguishing features		
The surface is relatively rough, and solidified zinc may block small holes. Newly galvanized surfaces are bright shining; high temperature galvanized part such as screws are grey.	Smooth surface depending on the process, slightly greased. Holes and cut edges expose "bare metal". Corrosion protection of "bare" edges up to 2 mm material thickness is provided by the by cathodic protection effect. 1	Iridescent shimmer, bright and shiny surface after passivation.
Usage - Application		
Welded components, equipment exposed to the weather.	Non-welded components up to 2 mm thick, especially for interior building work.	For parts in almost all shapes and sizes, corrosion protection and decorative finish. Recommended for dry, indoor areas only.
Corrosion Protection (typical annual degradation for Central Europe)		Corrosion Protection
Depending on the atmospheric conditions and the local environment. Rural 0.1 - 1.0 µm Suburban 1.0 - 2.0 µm Marine 2.0 - 4.0 µm 2	Annual degradation almost unmeasurable in dry indoor areas without pollution.	Salt spray tests according to DIN EN ISO 9227 NSS show up to 360 hours before rusting depending on the thickness of the zinc layer and the passivation method.

1 Components over 2 mm in material thickness are hot dip galvanized at Niedax

2 Local environmental conditions would be for instance the direct corrosive effect of a chimney with CO₂ flue gases.

3 Chromating process is ROHS compliant.



Corrosion

All metal surfaces are affected by corrosion. Depending on the physical properties of the metal and the environment to which it is exposed, chemical or electromechanical corrosion may occur.

ATMOSPHERIC CORROSION

Atmospheric corrosion occurs when metal is exposed to airborne liquids, solids or gases. Some causes of atmospheric corrosion are moisture, salt, dirt and sulphuric acid. This form of corrosion is typically worse outdoors, especially near marine environments.

CHEMICAL CORROSION

Chemical corrosion takes place when metal comes in direct contact with a corrosive solution. Some factors which affect the severity of chemical corrosion include: chemical concentration level, duration of contact, frequency of washing, and operating temperature.

STORAGE CORROSION

Wet storage stain (White rust) is caused by the entrapment of moisture between the surfaces of closely packed and poorly ventilated materials for an extended period of time. Wet storage stain is usually superficial, having no affect on the properties of the metal.

Light staining normally disappears with weathering. Medium to heavy buildup should be removed, in order to allow the formation of the normal protective film.

Proper handling and storage will help to assure stain-free material. If product arrives wet, it should be unpacked and dried before storage. Dry material should be stored in a well ventilated "low moisture" environment to avoid condensation. Outdoor storage is undesirable, and should be avoided whenever possible.

GALVANIC CORROSION

Galvanic corrosion occurs when two or more dissimilar metals are in contact while in the presence of an electrolyte (ie. moisture). An electrolytic cell is created and the metals form an anode or a cathode depending on their relative position on the Galvanic Series Table. The anodic material will be the one to corrode. Whether a material is anodic depends on the relative position of the other material. For example: If zinc and steel are in contact, the zinc acts as the anode and will corrode; the steel acts as the cathode, and will be protected. If steel and copper are in contact, the steel is now the anode and will corrode.

The rate at which galvanic corrosion occurs depends on several factors:

1. The amount and concentration of electrolyte present – Material stored in an indoor, dry environment will have little or no galvanic corrosion compared to a wet atmosphere.
2. The relative size of the materials – A small amount of anodic material in contact with a large cathodic material will result in greater corrosion. Likewise, a large anode in contact with a small cathode will decrease the rate of corrosive attack.
3. The relative position on the Galvanic Series Table. The farther apart in the Galvanic Series Table, the greater the potential or corrosion of the anodic material.

It is very important to consider the effects of electrolytic corrosion when selecting the assembly hardware. Ideally the finish of cable tray and hardware should be identical. But if this is not possible the relatively small hardware should always be higher grade than the large volume tray, e.g. use stainless steel bolts for hot dip galvanized tray but not the other way round.

GENERAL INFORMATION

Corrosion Guide

Chemical	Cable Tray Material					
	Stainless Type 304			Stainless Type 316		
	Cold	Warm	Hot	Cold	Warm	Hot
Acetone	R	R	R	R	R	R
Aluminum Chloride Solution	NR	–	–	F	–	–
Anhydrous Aluminum Chloride	NR	–	–	F	–	–
Aluminum Sulfate	R	R	R	R	R	R
Ammonium Chloride 10%	R	R	R	R	R	R
Ammonium Hydroxide	R	R	R	R	R	R
Ammonium Phosphate	R	–	–	R	–	–
Ammonium Sulfate	R	R	R	R	R	R
Ammonium Thiocyanate	R	–	–	R	R	R
Amyl Acetate	R	R	R	R	R	R
Amyl Alcohol	R	–	–	R	R	R
Arsenic Acid	R	R	–	R	R	R
Barium Chloride	R	R	R	R	R	R
Barium Sulfate	R	R	–	R	R	–
Barium Sulfide	R	R	–	R	R	–
Benzene	R	R	R	R	R	R
Benzoic Acid	R	R	R	R	R	R
Boric Acid	R	R	R	R	R	R
Bromine Liquid or Vapor	NR	NR	NR	NR	NR	NR
Butyl Acetate	R	–	–	R	R	R
Butyl Alcohol	R	R	R	R	R	R
Butyric Acid	R	R	R	R	R	R
Calcium Chloride 20%	R	–	–	R	–	–
Calcium Hydroxide	R	R	F	R	R	R
Calcium Hypochlorite 2 - 3%	R	–	–	R	–	–
Calcium Sulfate	R	R	–	R	R	–
Carbon Monoxide Gas	R	R	R	R	R	R
Carbon Tetrachloride	F	F	F	R	R	R
Chloroform Dry	R	R	–	R	R	–
Chloroform Solution	–	–	–	–	–	–
Chromic Acid 10% CP	R	R	F	R	R	R
Citric Acid	R	R	NR	R	R	R
Copper Cyanide	R	R	R	R	R	R
Copper Sulfate 5%	R	R	R	R	R	R
Ethyl Alcohol	R	R	R	R	R	R
Ethylene Glycol	R	R	–	R	R	R
Ferric Chloride	NR	NR	NR	NR	NR	NR
Ferrous Sulfate 10%	R	R	–	R	R	–
Formaldehyde 37%	R	R	R	R	R	R
Formic Acid 10%	R	R	NR	R	R	R
Gallic Acid 5%	R	R	R	R	R	R
Hydrochloric Acid 25%	NR	NR	NR	NR	NR	NR
Hydrofluoric Acid 10%	NR	NR	NR	NR	NR	NR

R = Recommended

F = May be used under some conditions

NR = Not Recommended

– = Information not available

Cold = 50 - 80°F

Cold = 10 - 27°F

Warm = 130 - 170°F

Warm = 54 - 77°F

Hot = 200 - 212°F

Hot = 93 - 100°F

The corrosion data given in this table is for general comparison only. (Reference Corrosion Resistance Tables, Second Edition)
The presence of contaminants in chemical environments can greatly affect the corrosion rate of any material.



Chemical	Cable Tray Material					
	Stainless Type 304			Stainless Type 316		
	Cold	Warm	Hot	Cold	Warm	Hot
Hydrogen Peroxide 30%	R	R	R	R	R	R
Hydrogen Sulfide Wet	NR	NR	R	R	R	R
Lactic Acid 10%	R	R	F	R	R	R
Lead Acetate 5%	R	R	R	R	R	R
Magnesium Chloride 1%	R	F	R	–	R	R
Magnesium Hydroxide	R	R	–	R	R	–
Magnesium Nitrate 5%	R	R	R	R	R	R
Nickel Chloride	R	–	–	R	–	–
Nitric Acid 15%	R	R	R	R	R	R
Oleic Acid	R	R	F	R	R	R
Oxalic Acid 10%	NR	NR	NR	R	R	R
Phenol CP	R	R	R	R	R	R
Phosphoric Acid 50%	R	R	R	R	F	NR
Potassium Bromide 100%	R	R	–	R	R	R
Potassium Carbonate 100%	R	R	R	R	R	R
Potassium Chloride 5%	R	R	R	R	R	R
Potassium Dichromate	R	R	R	R	R	R
Potassium Hydroxide 50%	R	R	R	R	R	R
Potassium Nitrate 50%	R	R	R	R	R	R
Potassium Sulfate 5%	R	R	R	R	R	R
Propyl Alcohol	R	R	R	R	R	R
Sodium Acetate 20%	R	R	R	R	R	R
Sodium Bisulfate 10%	R	R	R	R	–	–
Sodium Borate	R	R	R	R	R	R
Sodium Carbonate 18%	R	R	R	R	–	–
Sodium Chloride 5%	R	R	R	R	R	–
Sodium Hydroxide 50%	R	R	R	R	R	R
Sodium Hypochlorite 5%	F	–	–	R	–	–
Sodium Nitrate 100%	R	R	R	R	R	R
Sodium Nitrite 100%	R	R	R	R	R	R
Sodium Sulfate 100%	R	R	R	R	R	R
Sodium Thiosulfate	R	R	R	R	R	R
Sulfur Dioxide (Dry)	R	R	R	R	R	R
Sulfuric Acid 5%	F	NR	NR	R	–	–
Sulfuric Acid 10%	NR	NR	NR	NR	NR	NR
Sulfuric Acid 50%	NR	NR	NR	NR	NR	NR
Sulfuric Acid 75 - 98%	NR	NR	NR	NR	NR	NR
Sulfuric Acid 98 - 100%	NR	NR	–	R	R	F
Tannic Acid 10% and 50%	R	R	R	R	R	R
Tartaric Acid 10% and 50%	R	R	R	R	R	R
Vinegar	R	R	R	R	R	R
Zinc Chloride 5% and 20%	R	F	NR	R	R	R
Zinc Nitrate	R	R	R	R	R	R
Zinc Sulfate	R	R	R	R	R	R

Mechanical Properties

LENGTHS AVAILABLE

The current Cable Tray Standard, NEMA VE-1 and C22.2 No. 126.1-98, lists typical lengths as 3000 mm (10 ft), 3660 mm (12 ft), 6000 mm (20 ft), and 7320 mm (24 ft). It is impractical to manufacture either lighter systems in the longer lengths or heavier systems in the shorter lengths. For that reason, Niedax has introduced a primary and secondary length for some systems. These straight section lengths were selected to direct the user to trays that best suit support span demands and practical loading requirements. The primary length is the one that is the most appropriate for the strength of the system and that will provide the fastest service levels. The secondary lengths will be made available to service additional requirements. Special lengths are available upon request with extended lead times.

The VE-2, Cable Tray Installation Guide, states that the support span shall not be greater than the straight section length. If a 20C system is manufactured in 12 foot sections the greatest span for supports would be 12 feet. This dramatically affects the loading of the system.

$$\begin{aligned}W_1 \times L_1^2 &= W_2 \times L_2^2 \\100 \times 20^2 &= W_2 \times 12^2 \\40,000 &= 144 \times W_2 \\W_2 &= 277 \text{ lbs. per foot}\end{aligned}$$

SUPPORT SPAN

The strength of a cable tray system is largely determined by the strength of its side rails. The strength of a cable tray side rail is proportionate to the distance between the supports on which it is installed, commonly referred to as the "support span". Therefore, the strength of a cable tray system can be altered by changing the support span. However, there is a limit to how much that strength can be increased by reducing the support span. At a certain point the strength of the bottom portion of the cable tray could become the determining factor of strength.

Once the load requirement has been determined, the following factors should be considered:

1. Sometimes the location of existing structural beams will dictate the cable tray support span. This is typical with outdoor installations where adding intermediate supports could be financially prohibitive. For this situation the appropriate cable tray must be selected to accommodate the existing span.
2. When cable tray supports are randomly located, the added cost of a higher strength cable tray system should be compared to the cost of additional supports.
3. The support span lengths should be equal to or less than unspliced straight section lengths, to ensure that no more than one splice is placed between supports.

The distance between the supports affects the loading capabilities exponentially. To calculate loading values not listed use:

$$\begin{aligned}W_1 \times L_1^2 &= W_2 \times L_2^2 \text{ where} \\W_1 &= \text{tested loading} \\L_1 &= \text{span in feet, a tested span} \\W_2 &= \text{loading in question} \\L_2 &= \text{known span for new loading}\end{aligned}$$

Other Loads - Ice, wind, snow for outdoor systems see page 41 and 42 for information.

A 200 lb. concentrated load for industrial systems. The affect of a concentrated load can be calculated as follows:

$$2 \times (\text{concentrated static load}) / \text{span in feet}$$

When considering concentrated loads the rung strength should be factored in.

DEFLECTION

Deflection in a cable tray system is primarily an aesthetic consideration. When a cable tray system is installed in a prominent location, a maximum simple beam deflection of 1/200 of support span can be used as a guideline to minimize visual deflection.

It is important at this point to mention that there are two typical beam configurations, simple beam and continuous beam, and to clarify the difference.

A good example of a simple beam is a single straight section of cable tray supported, but not fastened at either end. When the tray is loaded the cable tray is allowed to flex. Simple beam analysis is used almost universally for beam comparisons even though it is hardly practical in the field. The three most prominent reasons for using a simple beam analysis are: calculations are simplified; it represents the worst case loading; and testing is simple and reliable.

Continuous beam is the beam configuration most commonly used in cable tray installations. An example of this configuration is where cable trays are installed across several supports to form a number of spans. The continuous beam possesses traits of both the simple and fixed beams. When equal loads are applied to all spans simultaneously, the counter-balancing effect of the loads on both sides of a support restricts the movement of the cable tray at the support. The effect is similar to that of a fixed beam.

The end spans behave substantially like simple beams. When cable trays of identical design are compared, the continuous beam installation will typically have approximately half the deflection of a simple beam of the same span. The published load data in the NIEDAX cable tray catalog is based on the continuous beam analysis per IEC - Standard 61537. Therefore simple beam data should be used only for general comparison purposes.

Please note that NEMA Standards VE-1 limits the use of splice plates as follows:

Unspliced straight sections should be used on all simple spans and on end spans of continuous span runs. Straight section lengths should be equal to or greater than the span length to ensure not more than one splice between supports.

CONCENTRATED LOADS

A concentrated static load represents a static weight applied at a single point between the side rails. Tap boxes, conduit attachments and long cable drops are just some of the many types of concentrated loads. When specified, these concentrated static loads may be converted to an equivalent, uniform load (W_e) by using the following formula:

$$W_e = 2 \times (\text{concentrated Static Load}) / \text{span length}$$

However, it should be noted that per NEMA Standard Publication VE1 cable tray is designed as a support for power or control cables, or both, and is not intended or designed to be a walk-way for personnel.

POWER CABLING LOADS

Power applications can create the heaviest loading. The heaviest cable combination found was for large diameter cables (i.e. steel armor, 600V, 4 conductor 750 kcmil). The cables weigh less than 3.8 lbs. per inch-width of cable tray. As power cables are installed in a single layer, the width of the cable affects the possible loading.

DATA/COMMUNICATION CABLING LOADS

Low voltage cables can be stacked as there are no heat generation problems. The NEC employs a calculation of the total cross sectional area of the cables not exceeding 50% of the fill area of the cable tray. As the cable fill area of the cable tray system affects the possible loading, both the loading depth and width of the systems must be considered. For this example 4UTP category 5 cable (O.D. = .21, .026 lbs./ft.) were used.

Mechanical Properties

ENVIRONMENTAL LOADS: WIND

Wind loads need to be determined for all outdoor cable tray installations. Most outdoor solutions are ladder type trays, therefore the most severe loading to be considered is impact pressure normal to the cable tray side rails. The impact pressure corresponding to several wind velocities are given below in Table 1.

V(mph)	P(lbs/ft ²)	V(mph)	P(lbs/ft ²)
15	0.58	85	18.5
20	1.02	90	20.7
25	1.60	95	23.1
30	2.30	100	25.6
35	3.13	105	28.2
40	4.09	110	30.9
45	5.18	115	33.8
50	6.39	120	36.8
55	7.73	125	40.0
60	9.21	130	43.3
65	10.80	135	46.6
70	12.50	140	50.1
75	14.40	145	53.8
80	16.40	150	57.6

V= Wind Velocity P= Impact Pressure

Note: These values are for an air density of 0.07651lbs/ft³ corresponding to a temperature of 16°C (60° F) and baro-metric pressure of 14.7 lbs/in².

Example Calculation:

Side load for 6" side rail with 100 mph wind (25.6 x 6)/12 = 12.8 lbs/ft

When covers are installed on outdoor cable trays, another factor to be considered is the aerodynamic effect which can produce a lift strong enough to separate a cover from a tray. Wind moving across a covered tray creates a positive pressure inside the tray and a negative pressure above the cover. This pressure difference can remove the cover from the tray.

ENVIRONMENTAL LOADS: ICE

Glaze ice is the most commonly seen form of ice build-up. It is the result of rain or drizzle freezing on impact with an exposed object. Generally, only the top surface (or the cover) and the wind bearing side of a cable tray system is significantly coated with ice. The maximum design load to be added due to ice should be calculated as follows:

$$L_i = (W \times T_i \times D_i) / 144 \text{ where;}$$

$$L_i = \text{Ice Load (lbs/linear foot)}$$

$$W = \text{Cable Tray Width (inches)}$$

$$T = \text{Maximum Ice Thickness (inches)}$$

$$D_i = \text{Ice Density} = 57 \text{ lbs/ft}^3$$

the maximum ice thickness will vary depending on location. A thickness of 1/2" can be used as a conservative standard.

Example Calculation:

Ice Loads for 24" wide tray with 1/2" thick ice; (24 x 0.5 x 57) / 144 = 4.75 lbs/ft

ENVIRONMENTAL LOADS: SNOW

Snow is measured by density and thickness. The density of snow varies almost as much as its thickness. The additional design load from snowfall should be determined using the building codes which apply for each installation.



NOTES

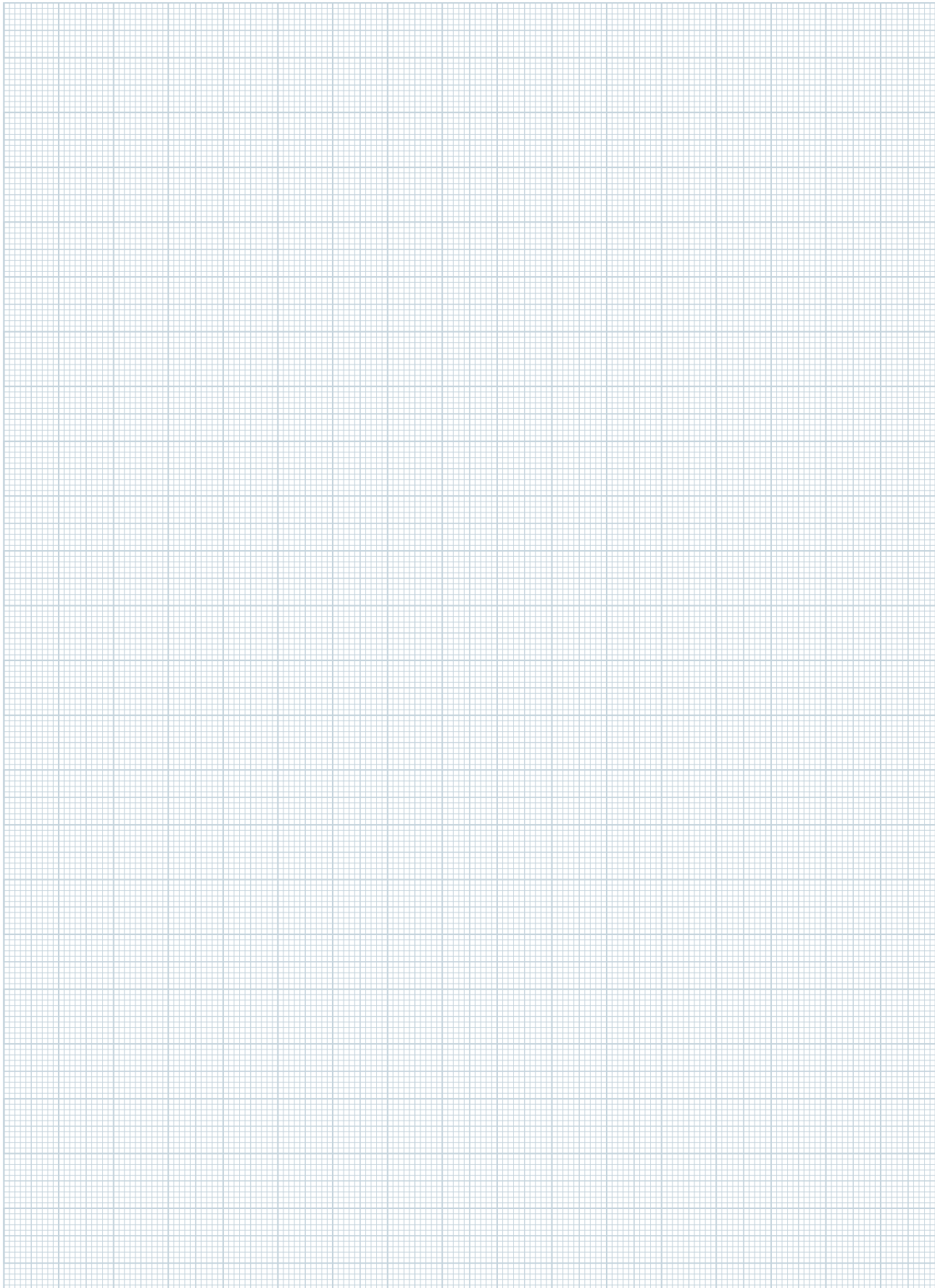

Plastic/Elastomer

PLASTIC MATERIALS

are changing their properties with temperature fluctuations. These synthetic materials should be stored at room temperature, before being installed in cold environments (below 0° Celsius or 32° Fahrenheit) to ensure full functionality.

Catalogue icon	Abbr	Material description	Operating temperature range	Mechanical properties	Range of application (examples)	Stress cracking
K01	PA	Polyamide, halogen-free	-30°C to 80°C	stiff, hard, very solid, very tough, abrasion-resistant	Cable glands, collecting holder, cable bracket, plug terminals	low
K02	PS	Polystyrene, halogen-free	-30°C to 60°C	brittle, notch-sensitive, stiff, very hard	Cable glands, row clamps, counter trough	powerful
K03	PE	Polyethylene, halogen-free	-40°C to 80°C	soft to stiff, tough, low strength	Protective caps, round clamps, counter trough	powerful
K04	PP	Polypropylene, halogen-free	-40°C to 90°C	form stiff, hard, solid, lower notched impact strength	Terminal housings, pipe clamps, nail clamps	possible
K05	PC	Polycarbonate, halogen-free	-40°C to 120°C	high strength, hardness and toughness, impact-resistant	Terminal housing	possible
K06	SBR/NBR	Styrene butadiene nitrile rubber, halogen-free	-30°C to 100°C	good abrasion and weather resistance	Sealing rings	no
K07	CR	Neoprene (Chloroprene rubber), halogenated	-40°C to 120°C	good weather, chemical and ageing resistance	Sealing rings	no
K08	NBR	Nitrile butadiene rubber, halogen-free	-40°C to 120°C	flexible at low temperatures, high impact elasticity, low weather resistance	Sealing rings	no
K09	PVC	Polyvinyl chloride hard, halogenated	-20°C to 65°C	solid, stiff, hard, low notch sensitivity	Plastic ducts	low
K10	Soft PVC	Polyvinyl chloride soft, halogenated	0°C to 50°C	flexible, soft, good abrasion resistance	Protective caps	no
K11	ABS	Acrylonitrile butadiene styrene, halogen-free	-30°C to 80°C	very tough even with low temperatures, hard, stiff, scratch-resistant	Mounting plates, fittings for plastic ducts	low
K12	ASA	Acrylic acid ester-styrene-acrylonitrile graft copolymer, halogen-free	-30°C to 85°C	impact resistant even in the cold, strength similar to ABS	Device tank housing	low
K14	POM	Polyoxymethylene, halogen-free	-40°C to 100°C	solid, stiff, tough, also at high temperatures, elastic spring behaviour	Cable brackets	few
K15	SBR	Styrene butadiene rubber, halogen-free	-50°C to 100°C	high abrasion resistance, good heat and cold resistance	Sealing rings	no
K16	CR/NBR	Chloroprene/Nitrile butadiene rubber, halogenated	-20°C to 100°C	high impact elasticity, improved weather resistance	Sealing rings	no
K17	CR/SBR	Chloroprene/Styrene butadiene rubber, halogenated	-20°C to 70°C	high abrasion resistance, lower heat and cold-resistance	Sealing rings	no
K18	TPE	Thermoplastic elastomers, halogen-free	-40°C to 120°C	very good resistance to weathering, ozone and ageing	Sealing rings	no
K19	FS 31	Moulding material 31 (Phenolic resin), halogen-free	to 125°C	high strength, high hardness, high temperature resistance	Illumination sockets	low
K20	SI	Silicone rubber, halogen-free	-40°C to 180°C	good ageing and high temperature stability	Sealing rings	no
K21	PUR	Polyurethanes, halogen-free	-25°C to 60°C	high tensile strength, buckling and abrasion resistance	Industrial hoses, seals, adhesives	low
K22	PET	Polyethylene terephthalate, halogen-free	-40°C to 190°C	high strength, very low moisture absorption	Illumination sockets	low
K23	UP-GF	Glass fiber reinforced polyester, halogen-free	-50°C to 180°C	high strength, high hardness, high temperature resistance	Cable duct, handrail, construction profiles	low
K24	PBT	Polybutylene terephthalate, halogen-free	-50°C to 150°C	high strength, high abrasion resistance, good chemical resistance	Illumination sockets	no

The information on halogen-free properties is based on searches of the relevant technical literature or supplier information. The statements always refer to chemically pure materials without flame-retardants. Tests according to DIN EN 50642 have not been carried out.



CHEMICAL RESISTANCES

Catalogue icon	Water	Acids (10%)	Alkalis (10%)	Alcohol (ethanol)	Petrol	Benzene	Mineral oil	Vegetable and animal fats	Solvent
K01	+	o	+	+	o	+	o	+	o
K02	+	o	+	+	-	-	o	o	+
K03	+	+	+	+	o	-	o	+	-
K04	+	+	+	+	o	o	+	+	o
K05	+	o	-	+	-	-	+	+	o
K06	+	o	o	+	-	-	o	o	o
K07	+	-	-	+	o	+	o	o	o
K08	+	o	+	+	+	o	+	o	o
K09	+	+	+	+	+	-	+	+	-
K10	+	+	o	+	-	N/A	-	o	-
K11	+	o	N/A	+	-	-	+	-	-
K12	+	o	o	+	-	-	+	+	-
K14	+	o	o	+	+	+	+	+	-
K15	+	+	+	+	-	-	-	-	o
K16	+	o	o	+	o	-	+	+	o
K17	+	o	o	N/A	-	-	o	N/A	N/A
K18	+	+	+	N/A	+	N/A	+	N/A	-
K19	+	o	o	+	+	o	+	N/A	o
K20	+	o	o	+	o	-	+	+	o
K21	+	-	-	N/A	+	N/A	+	+	o
K22	+	+	o	+	+	o	+	N/A	o
K23	+	+	+	+	+	o	+	+	+
K24	+	o	+	+	+	o	+	+	o

+ = constant o = conditionally constant - = inconstantly N/A = not available

Source: Plastic tables, e.g. Plastic Compendium, Franck, Vogel-book publisher, manufacturers' data sheets

The information given in the tables is intended as a guide for the preselection of products and is based on our current knowledge.

The properties can be negatively influenced by the geometry of the products and the type of application.

More detailed information is available on request. To test the suitability of a product, a test under the specific environmental conditions is required.

Further chemical resistances can be found on our homepage at www.niedax.com > Download > Catalogues

GENERAL INFORMATION

Bonding and Grounding

The National Electrical Code states that all metallic cable trays supporting electrical conductors shall be properly bonded (NEC 250.90 and NEC 250.96) and grounded (NEC 392.7).

- Definition: **Bonding** grants electrical continuity of separate sections (of cable tray).
- Definition: **Grounding** grants a low impedance (direct) connection to earth.
- Standards: According to NEC a properly bonded system can be used as an EGC (equipment grounding conductor) within the limits of NEC Table 392.7(B), i.e. the cable tray can replace the green (ground) wire. This standard is valid only in the US!

Maximum Fuse / Circuit Breaker Ampere Rating	60 A	100 A	200 A	400 A	600 A
Minimum Cross Sectional Area of Steel	0.20 sq in	0.40 sq in	0.70 sq in	1.00 sq in	1.5 sq in
	129 mm ²	258 mm ²	452 mm ²	645 mm ²	968 mm ²

- Standards: In Canada (and almost the rest of the world) cable trays can't be used as a grounding conductor.
- This difference in electrical standards leads to two different UL classifications:



- The C-UL-US classified trays can be used as EGC in the US, the C-UL trays not. But both labels grant proper bonding according to NEC and CSA as long as UL rated splices are used.

<h1>WARNING!</h1> <p>Do Not Use As A Walkway, Ladder, Or Support For Personnel.</p> <p>Use Only As A Mechanical Support For Cables, Tubing and Raceways.</p>		



Bonding of Cable Tray

Per NEC 392, the National Electrical Code section for cable tray, all cable tray systems must be properly BONDED (section 250.96). To meet this requirement, Niedax recommends that UL classified splicing solutions are used to join sections and that the cable tray be bonded to building steel or the facility grounding system.

The integrated splices of Niedax MTC wire mesh tray and all standard splices (e.g. RVVX for cable trays, WSVX for long span ladders) are providing proper bonding between sections. These splices have been tested by UL as part of the cable tray grounding system.

Niedax steel support systems (e.g. the HU hanger series or C-rail trapeze kits) clamped securely to building steel usually provide a solid bond. If supports are installed to concrete or other nonconductive materials supplementary bonding jumpers from the tray to the building steel are required about every 20 meters.

Because all cable tray needs to be electrically continuous per NEC 250.96 painted/powder-coated tray requires the outer mask of the conductive surface to be removed at each end of the tray prior to installing any splices to ensure a UL Classified Bonding continuity between painted tray sections. The other way to guarantee proper bonding for painted/powder-coated tray would be to install a continuous equipment ground wire along the tray. For each section of tray at least one UL classified grounding lug has to be installed directly to the conductive surface and connected to the EGC.

Niedax does not offer any UL listed grounding lugs and wires.

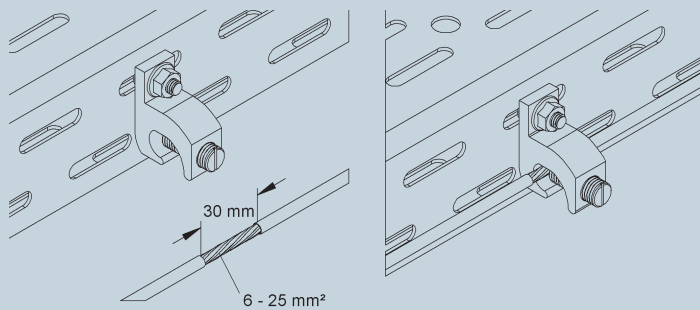

Installation Instructions

INSTALLATION

Attention Cable Tray Installers – Cable tray system design shall comply with NEC Article 392, NEMA VE 1, IEC 61537 and shall follow safe work practices as described in NFPA 70E and NEMA VE 2.

The instructions and information contained here-in are not intended to cover all details or variations in cable tray systems, nor do they account for every possible installation scenario.

It is recommended that the installation work described be performed by qualified personnel, preferably a certified electrical contractor, familiar with standard electrical construction practices, electrical equipment, and safety of electrical wiring systems.

TYPE OF CABLE

According to NEC Article 318, multiconductor tray cable may be installed in any standard cable tray bottom type. Single conductor tray cable may be installed only in ladder or ventilated bottom cable trays (not solid bottom). Solid bottom cable trays are not allowed to be installed in Class II, Division 2 locations (1999 NEC Section 502-4(b)). In general, small, highly flexible cables should be installed in solid bottom, vented bottom cable trays. Sensitive cables (e.g. fiberoptic) are typically installed in flat, solid bottom cable trays, instead of corrugated trough bottoms. Larger, less flexible cables are typically installed in ladder type cable trays having 12" rung spacing.

SUPPORT INSTALLATION

Caution! Supports for cable trays should provide strength and working load capabilities sufficient to meet the load requirement of the cable tray wiring system. Consideration should be given to the loads associated with future cable additions or any other additional loads applied to the cable tray system or the cable trays support system.

There are many different ways of supporting cable trays. The most common approach in the US is to use threaded rod and a rail to build a trapeze hanger. Other systems like ceiling hangers with cantilever brackets will allow cables to be laid into the tray instead of being pulled through.

STRAIGHT SECTION POSITION

After the supports are in place, the installation of the cable tray can begin at any place that is convenient. It is not necessary to start at one end of the run. It is ideal to lay out the system so that splice joints fall between the support and the quarter point. This maximizes the rigidity of the cable tray.

To begin, place a straight section across two supports so that the ends of the section are not directly on the support. If the support span is equal to the length of the straight sections, bolt two pieces together for this step. As a general practice, avoid placing splice plates over supports or at mid-span.

FIELD MODIFICATIONS

Cable Tray can be adapted (cut to spec in field situations). These field modifications should be made by qualified personnel only (preferably a certified electrical contractor).

BARRIER REQUIREMENTS

Barrier strips are used to separate cable systems, such as when cables above and below 600 volts per NEC 318-6(f) are installed in the same cable tray. However, when MC type cables rated for over 600 volts are installed in the same cable tray with cables rated 600 volts or less, no barriers are required. The barriers should be made of the same material type as the cable tray. When ordering the barrier, the height must match the loading depth of the cable tray into which it is being installed.



FUTURE EXPANSION REQUIREMENTS

One of the many features of cable tray is the ease of adding cables to an existing system. Future expansion should always be considered when selecting a cable tray, and allowance should be made for additional fill area and load capacity. A minimum of 50% expansion allowance is recommended.

SPACE LIMITATIONS

Any obstacles which could interfere with a cable tray installation should be considered when selecting a cable tray width and height. Adequate clearances should be allowed for installation of supports and for cable accessibility. Note: the overall cable tray dimensions typically exceed the nominal tray width and loading depth.

Fitting Radius

CABLE FLEXIBILITY

The proper bend radius for cable tray fittings is usually determined by the bend radius and stiffness of the tray cables to be installed. Typically, the tray cable manufacturer will recommend a minimum bend allowance for each cable. The fitting radius should be equal to or larger than the minimum bend radius of the largest cable which may ever be installed. When several cables are to be placed in the same cable tray, a larger bend radius may be desirable to ease cable installation.

Space Limitations

The overall dimensions for a cable tray fitting will increase as the bend radius increases. Size and cost make the smallest acceptable fitting radius most desirable. When large radius fittings are required, the system layout must be designed to allow for adequate space.

Fittings Installation

RECOMMENDED SUPPORT LOCATIONS FOR FITTINGS

The following are recommended support diagrams to serve as guidelines for installing Steel Cable Tray support systems in the field. The information is intended to provide the installer some practical assistance when estimating the amounts of necessary supports and to help in identifying support locations for various field conditions.

However, it does not cover every situation that may arise when installing the product. It may be possible to install narrow trays with lighter loads and fewer supports. Wider trays with heavier loading, trays with long radii, or those with multiple side cuts may require additional support to avoid unwanted deflection.

HORIZONTAL ELBOW SUPPORT

Supports for horizontal cable tray fittings should be placed within 2ft. (600 mm) of each fitting extremity, and as follows:

- a. 90° supports at the 45° point of arc.
- b. 60° supports at the 30° point of arc.
- c. 45° supports at the 22-1/2° point of arc (except for the 12 in. [300 mm] radii).
- d. 30° supports at the 15° point of arc (except for the 12 in. [300 mm] radii).

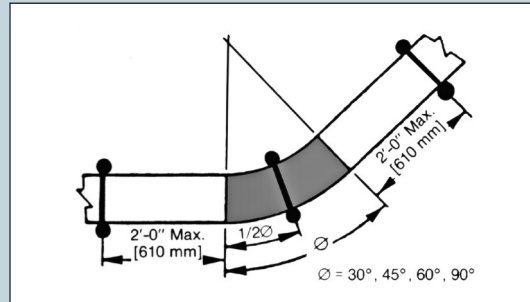

HORIZONTAL TEE SUPPORT

Place horizontal tee supports within 2 ft. (600 mm) of each of the three openings connected to other cable tray items for the 12 in. (300 mm) radius. On all other radii, at least one additional support should be placed under each side rail at the horizontal tee, preferably as shown.

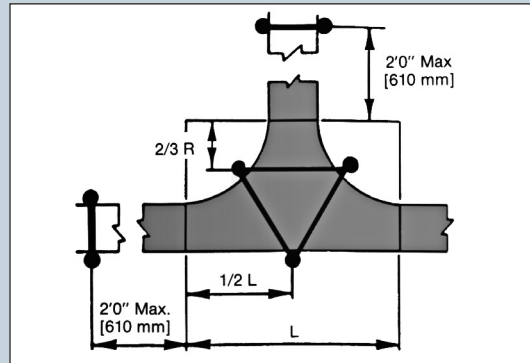

Other Factors To Consider

HORIZONTAL Y SUPPORT

Place horizontal Y supports within 2 ft. (600 mm) of each of the three openings connected to other cable tray items, and at 22-1/2° point of the arc adjacent to the side branch.

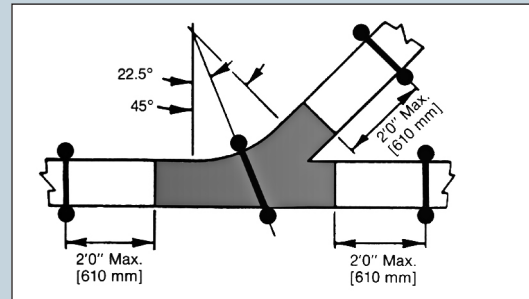

HORIZONTAL CROSS SUPPORT

Place horizontal cross support within 2 ft. (600 mm) of each of the four openings connected to other cable tray items for the 12 in. (300 mm) radius. On all other radii, at least one additional support should be placed under each side rail of the horizontal cross, preferably as shown.

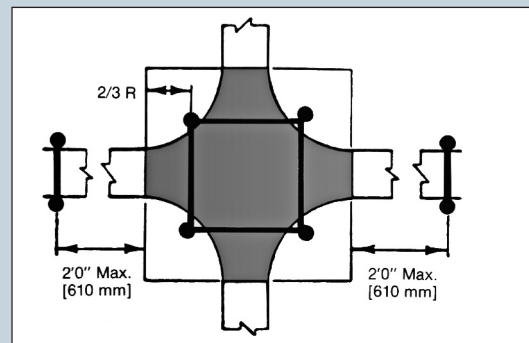

VERTICAL CABLE TRAY ELBOW

Vertical cable tray elbows at the top of runs should be supported at each end. At the bottom of runs, they should be supported at the top of the elbow and within 2 ft. (600 mm) of the lower extremity of the elbows.

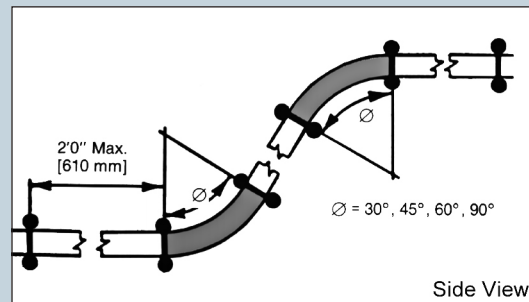

REDUCER SUPPORT

Place reducer supports within 2 ft. (600 mm) of each fitting extremity.

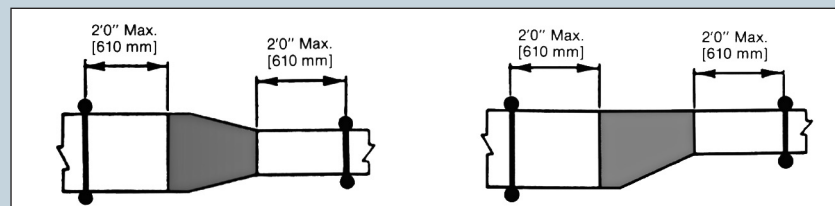

GENERAL INFORMATION

Technical Information

Expansion Anchor DAM

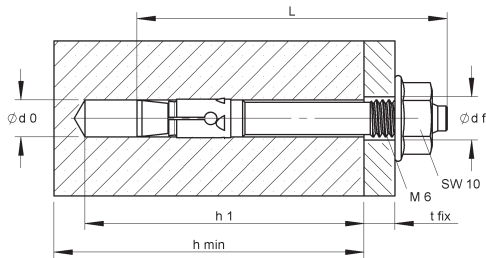

DAM 6X5
DAM 6X10

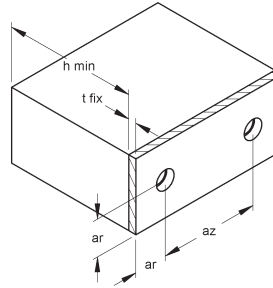

Permissible loads for centric pull, shear pull and diagonal pull at any angle and anchor characteristics and component dimensions for concrete strength class \geq B 25 or C 20/25 and \leq B 55 or C 50/60. The entire approval notice ETA-18/0541 shall be observed for the design. gvz = galvanized according to DIN EN ISO 2081/DIN EN ISO 4042, blue passivated.

Type of anchor		DAM 6X5 ¹⁾ gvz	DAM 6X10 ¹⁾ gvz
Permissible load of individual anchors	kN	2,4	2,4
Permissible bending moment M (without tensile load)	Nm	5,2	5,2
Max. Torque when mounting the attachment part with a torque wrench	Nm	4	4
Nominal drilling diameter $d_0 =$	mm	6	6
Blade diameter \leq	mm	6,4	6,4
Through hole in the component to be connected $d_f \leq$	mm	7,0	7,0
Minimum hole depth (t) $h_1 \geq$	mm	36	36
Minimum anchoring depth $h_v \geq$	mm	30	30
Centre distance between the outer dowels of adjacent dowel groups or single dowels $az \geq$	mm	200 ²⁾	200 ²⁾
Distance of the outer dowels to the edge of the component $ar \geq$	mm	100 ³⁾	100 ³⁾
Minimum thickness $h_{min} \geq$	mm	80	80
Total length $L =$	mm	50	55
Thickness of the attachment $t_{fix} \leq$	mm	5	10

- 1) The partial safety factors of the resistors regulated in the approval and a partial safety factor of the action $\gamma_F = 1.4$ are taken into account.
 - 2) The centre distance can be reduced to 100 mm while simultaneously reducing the permissible load.
 - 3) The edge distance can be reduced to 50 mm while reducing the permissible load.
- For outdoor use we recommend dowels made of stainless steel.

Technical Information

Expansion Anchor DAZ

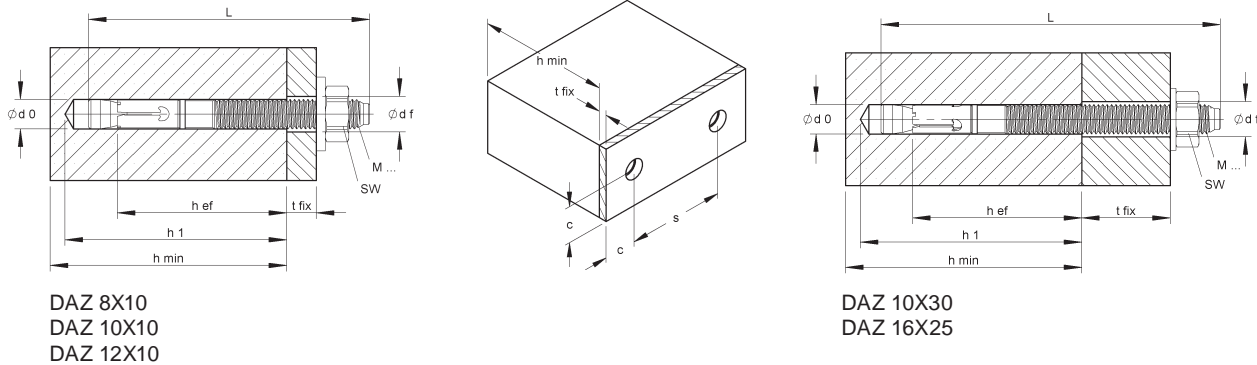

Maximum permissible loads¹⁾ of an anchor in normal concrete C20/25²⁾. The entire approval notice ETA-18/0542 shall be observed for the design.
gvz = galvanized to DIN EN ISO 2081/DIN EN ISO 4042, blue passivated.

Type of anchor		DAZ 8X10	DAZ 10X10 DAZ 10X30	DAZ 12X10	DAZ 16X25
Effective anchorage depth h_{ef}	mm	45	60	70	85
Permissible centric tensile load of a single anchor without boundary influence N_{zul} ³⁾					
Cracked concrete C20/25 ²⁾	kN	3,8	6,2	9,5	13,4
Non-cracked concrete C20/25 ²⁾	kN	6,7	9,5	10,5	18,8
Permissible shear force of a single anchor without boundary influence V_{zul} ³⁾					
Cracked and non-cracked concrete C20/C25 ²⁾	kN	7,8	12,2	17,5	31,4
Permissible bending moment (M_d) M_{zul}	Nm	14,8	29,7	52,6	133,1
Component dimensions and assembly parameters ⁴⁾					
Standard component thickness ($\geq 2 \times h_{ef}$) $h_{min,1} =$	mm	100	120	140	170
Minimum centre distance $s_{min} =$	mm	35 (40)	40	50	65
for $c \geq$	mm	50	55 (60)	70	95
Minimum edge distance $c_{min} =$	mm	40	45	55	65
for $s \geq$	mm	70 (100)	80	110	150
Reduced component thickness ($< 2 \times h_{ef}$) $h_{min,2} =$	mm	80	100	120	140
Minimum centre distance $s_{min} =$	mm	35	40	50	80
for $c \geq$	mm	70	100	90	130
Minimum edge distance $c_{min} =$	mm	40	60	60	65
for $s \geq$	mm	100	90	120	180
Nominal drilling diameter $d_0 =$	mm	8	10	12	16
Borehole depth (t) $h_1 \geq$	mm	55	75	90	110
Through hole in the component to be connected $df \leq$	mm	9	12	14	18
Torque during anchoring	Nm	20	45	60	110
Total length $L =$	mm	75	95 / 115	110	148
Minimum component thickness $t_{fix} =$	mm	10	10 / 30	10	25
Minimum thickness of the concrete component $h_{min} =$	mm	80	80	100	140

- 1) The partial safety factors of the resistors regulated in the approval and a partial safety factor of $\gamma_F = 1.4$ are taken into account.
For the combination of tensile and transverse loads, for boundary influences and for anchor groups, please refer to design procedure A (ETAG Annex C).
- 2) The concrete is assumed to be normally reinforced or unreinforced; for higher concrete strengths up to 55 % higher values are possible.
- 3) I.e. for tensile load: edge distance $c > 1.5 h_{ef}$ and centre distance $s > 3 h_{ef}$ or for shear force: $c > 10 h_{ef}$ and centre distance $s > 3 h_{ef}$.
- 4) The values in brackets only apply to non-cracked concrete.
For outdoor use we recommend dowels made of stainless steel.

Technical Information

Concrete Screw Anchor NSA

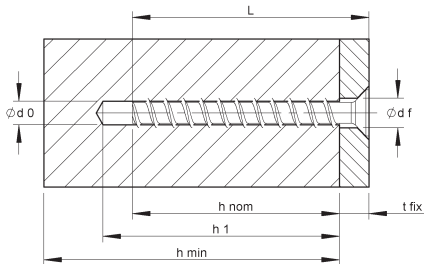

NSA 5X40/SK-T20 V

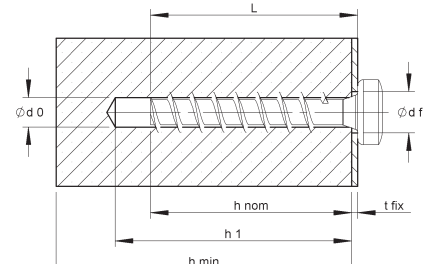

NSA 6X35/FKK-T30 V and NSA 6X50/FKK-T30 V

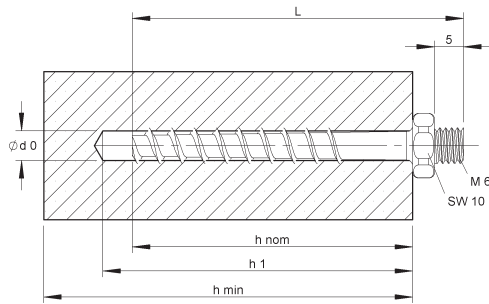

NSA 6X55/SW10-M6 V

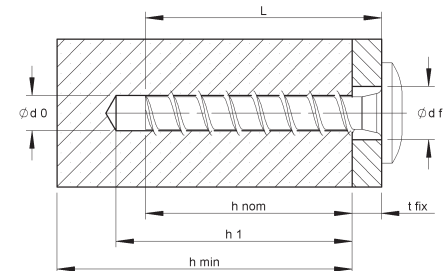
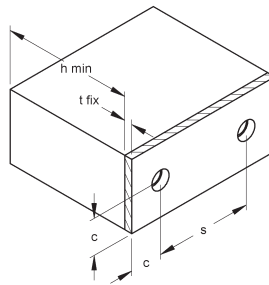

NSA 7.5X40/FKG-T30 V and NSA 7.5X50/FKG-T30 V

Maximum permissible loads¹⁾ of a single anchor for fixings in standard concrete C 20/25²⁾.

The entire approval notice ETA - 15/0784 must be observed for the design. gvz = galvanized according to DIN EN ISO 2081/DIN EN ISO 4042, blue passivated

Type of anchor		NSA 5X40/ SK-T20 V gvz	NSA 6X35/ FKK-T30 V gvz	NSA 6X50/ FKK-T30 V gvz	NSA 6X55/ SW10-M6 V gvz	NSA 7.5X40/ FKG-T30 V gvz	NSA 7.5X50/ FKG-T30 V gvz
Screw-in depth $h_{nom} \geq$	[mm]	35	35	45/35	45	35	35
Permissible centric tensile load of a single anchor without boundary influence $N_{zul}^{3)}$							
Cracked concrete C20/25 ²⁾	[kN]	1,8	0,5	0,7/0,5	0,7	1,0	1,0
Non-cracked concrete C20/25 ²⁾	[kN]	2,6	2,0	3,0/2,0	3,0	2,0	2,0
Permissible shear force of a single anchor without boundary influence $V_{zul}^{3)}$							
Cracked concrete C20/25 ²⁾	[kN]	2,0	2,3	2,4 ⁶⁾	2,4 ⁶⁾	2,4	2,4
Non-cracked concrete C20/25 ²⁾	[kN]	2,0	2,4 ⁶⁾	2,4 ⁶⁾	2,4 ⁶⁾	3,4	3,4
Permissible bending moment (M_{gr}) M_{zul}	[Nm]	-	4,0	4,0	4,0	8,4	8,4
Component dimensions and assembly parameters ⁴⁾							
Standard component thickness ($\geq 2 \times h_{gr}$) $h_{min, 1} =$	[mm]						
Minimum centre distance $s_{min} =$	[mm]	35	30	30	30	40	40
for $c \geq$	[mm]						
Minimum edge distance $c_{min} =$	[mm]	35	30	30	30	40	40
for $s \geq$	[mm]						
Nominal drilling diameter $d_0 =$	[mm]	4	5	5	5	6	6
Borehole depth (t) $h_1 \geq$	[mm]	40	40	50	50	40	40
Length L =	[mm]	40	35	50	55	40	50
Calculated anchorage depth $h_{gr} =$	[mm]	25	26	35	35	26	26
Through hole in the component to be connected $df \leq$	[mm]	6	7	7	7	9	9
Recommended max. power output Setting tool $Tinst^{5)}$ =	[Nm]	-	75	100	100	100	100
Recommended max. tightening torque $Tinst =$	[Nm]	8	-	-	-	-	-
Max. Thickness $t_{fix} =$	[mm]	5	1	5/15	-	5	15
Minimum thickness of the concrete component $h_{min} =$	[mm]	80	100	100	100	100	100

- 1) On the resistance side, the partial safety factors of the anchor resistances and the material partial safety factors of design methods A in accordance with Annex C of ETAG 001 or CEN/TS 1992-4 are taken into account. On the action side, a partial safety factor of $Y_G = 1.35$ was taken into account. For combined loads, anchor groups and axial or boundary influences, please observe the specifications for design methods A according to ETAG 001 Annex C or CEN/TS 1992-4 or our design aid.
- 2) The concrete is assumed to be normally reinforced or unreinforced; for higher concrete strengths, higher resistances may be possible.
- 3) I.e. for tensile load: edge distance $c \geq 1.5 \cdot h_{gr}$ and centre distance $s \geq 3 \cdot h_{gr}$ or for transverse force: $c \geq 10 \cdot h_{gr}$ and centre distance $s \geq 3 \cdot h_{gr}$.
- 4) The values in brackets only apply to non-cracked concrete.
- 5) The tightening torque is specified in the approval notice, compliance with this specification is therefore relevant to the approval.
- 6) Steel failure decisive.



Fastening torques based on VDI 2230

Fastening torques

The specified fastening torques are guidance values based on VDI 2230 standard. Please note that additional lubrication reduces friction and leads to undefined fastening situations.

Fastening torques for bolts with metric threads

Bolts with metric threads	Maximum fastening torque in Nm with a coefficient of friction $\mu=0.12$						
	Thread	Property classes					
		4.6	4.8	6.8	8.8	10.9	12.9
M6	3,7	4,7	7,5	10,1	14,9	17,4	
M8	9,1	11,3	18,2	24,6	36,1	42,2	
M10	18,3	22,9	36,5	48	71	83	
M12	31	39	62	84	123	144	
M14	50	62	100	133	195	229	
M16	76	96	153	206	302	354	

Fastening torques for metric bolts made from stainless steel

Metric bolts made from stainless steel	Maximum fastening torque in Nm with a coefficient of friction $\mu=0.12$		
	Thread	Property classes	
		50	70
M6	3	6	8
M8	7,1	16	22
M10	14	32	43
M12	24	56	75

GENERAL INFORMATION

Hole Patterns

RLCI 60...

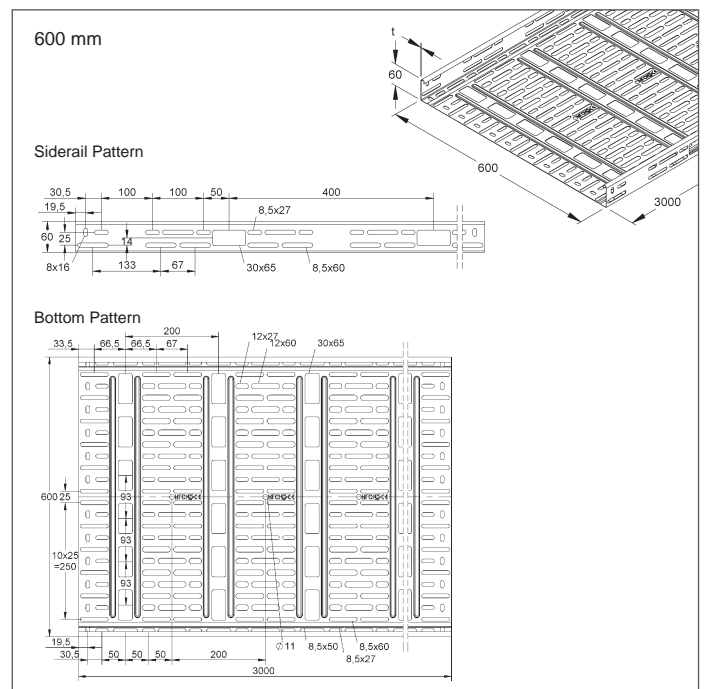
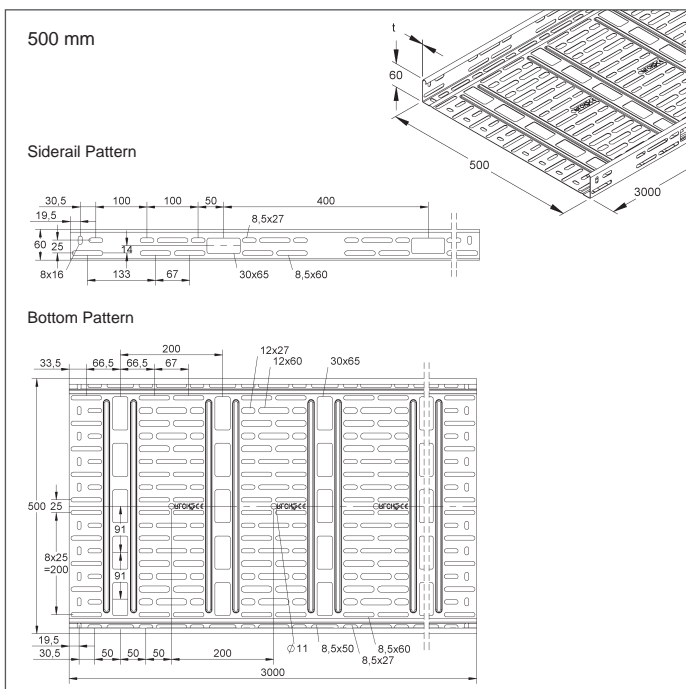
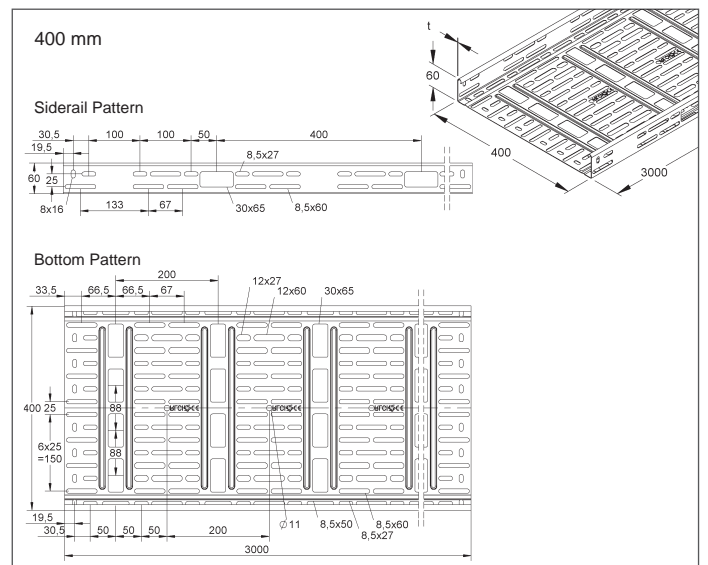
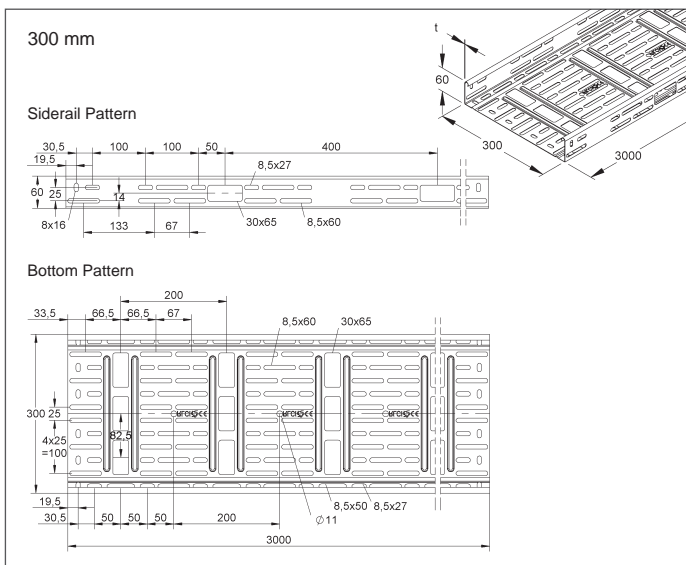
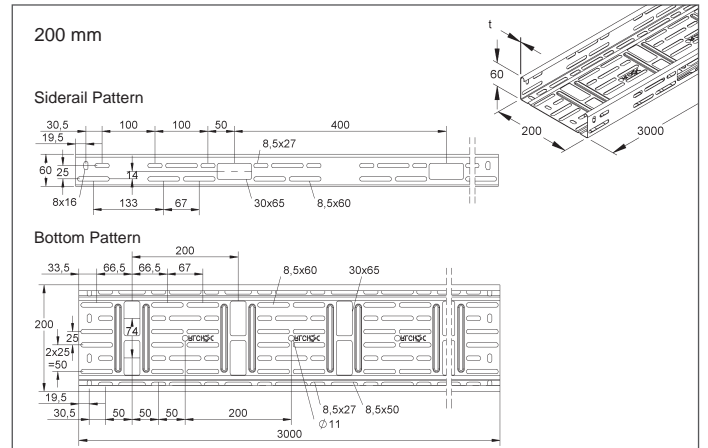
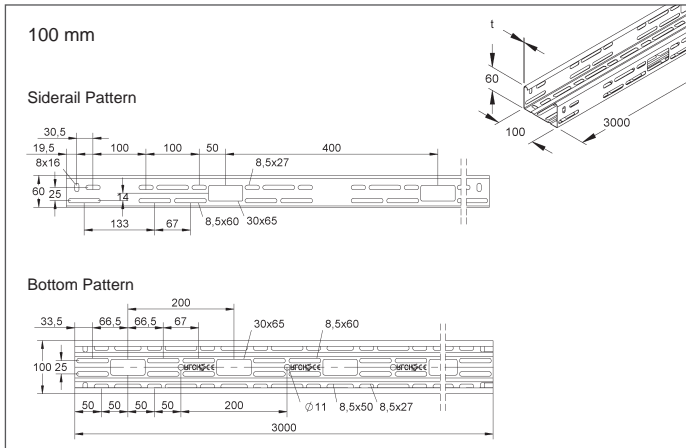

Hole Patterns

RSV 110...

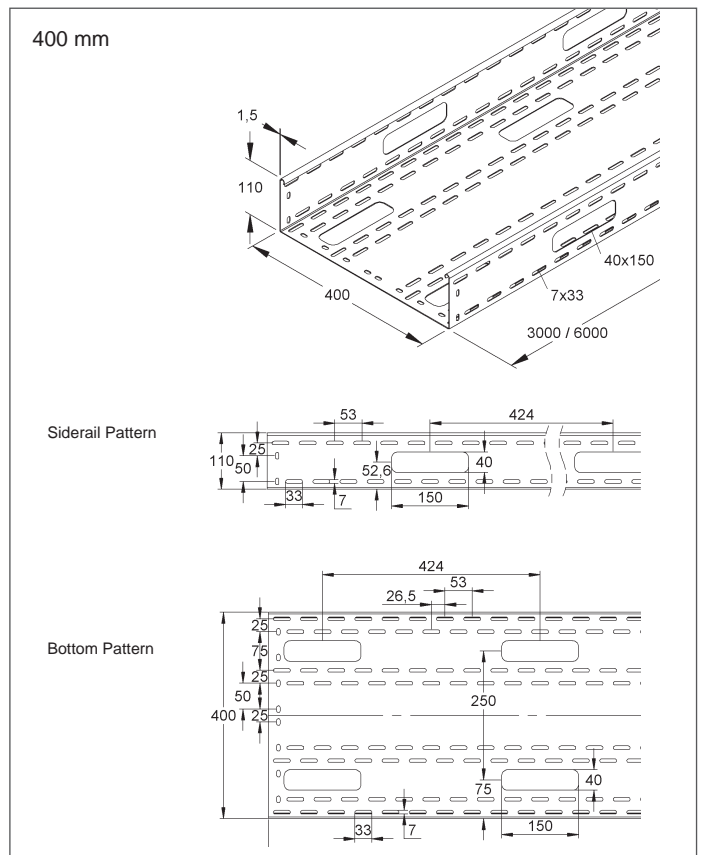
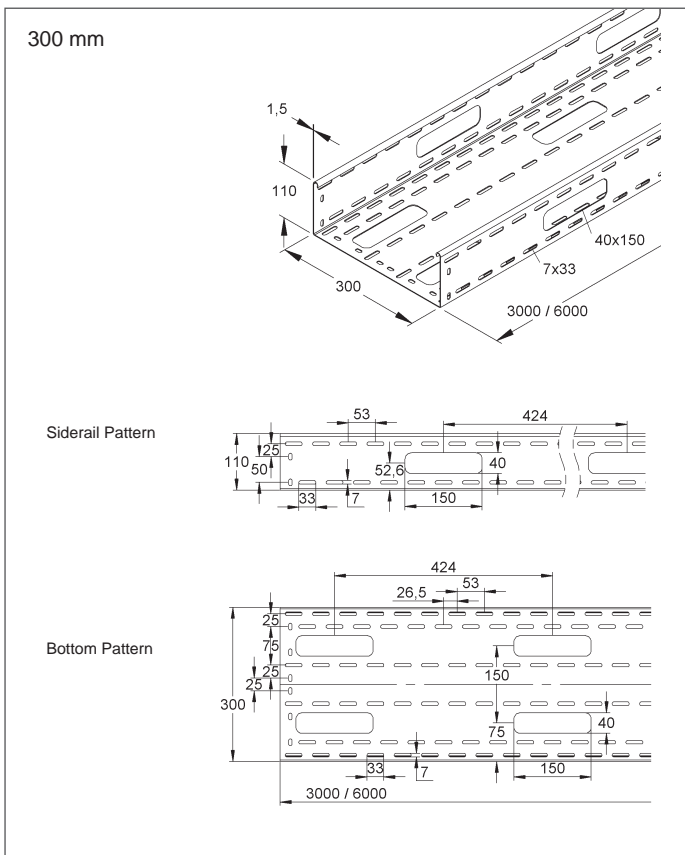
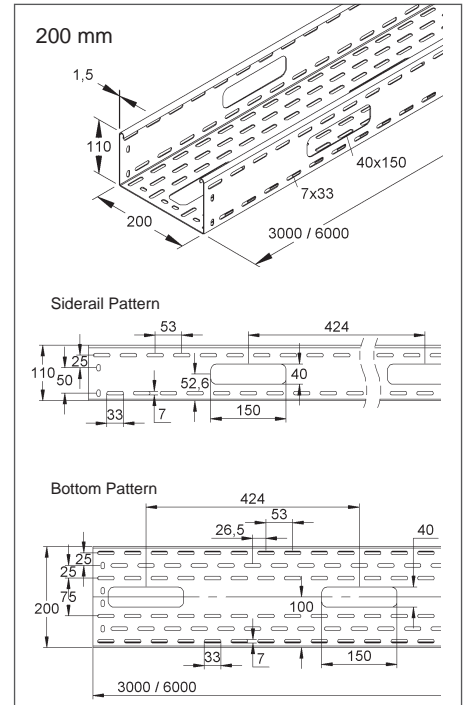
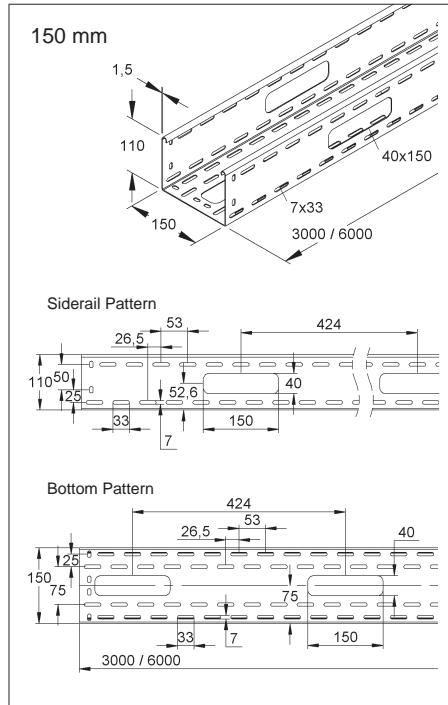
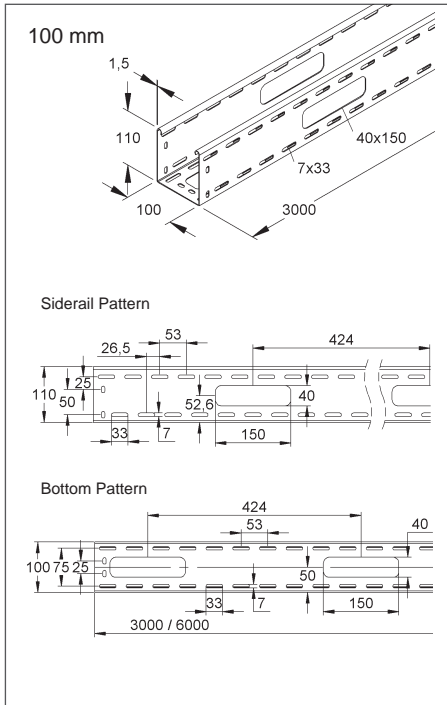

GENERAL INFORMATION

Installation Instructions

PKS...

Various applications possible.

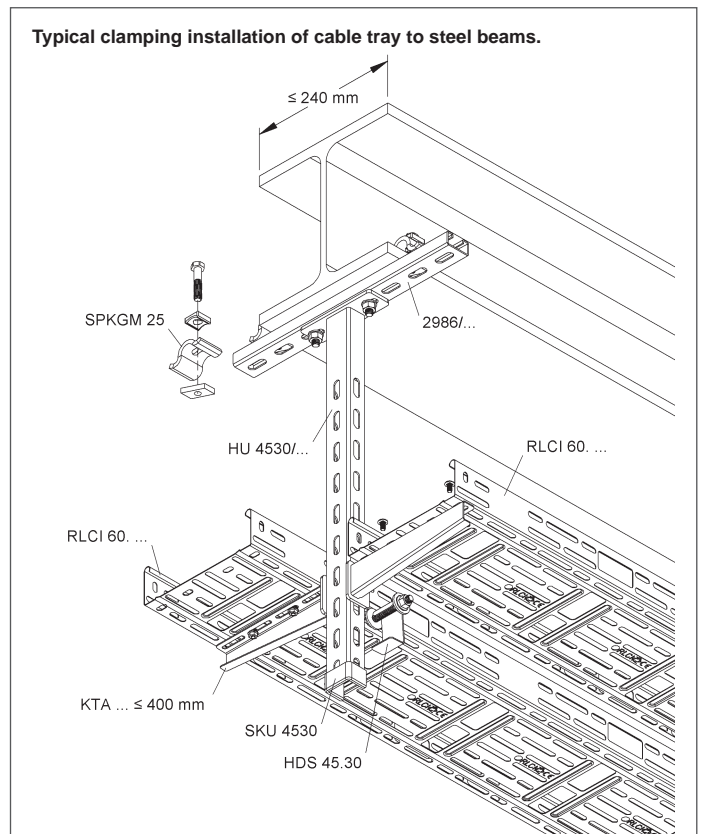
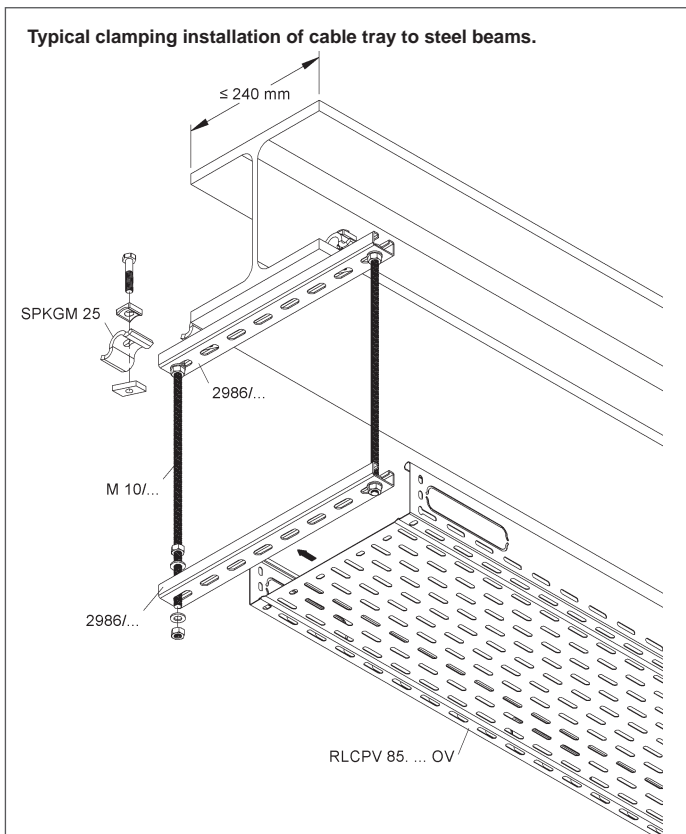
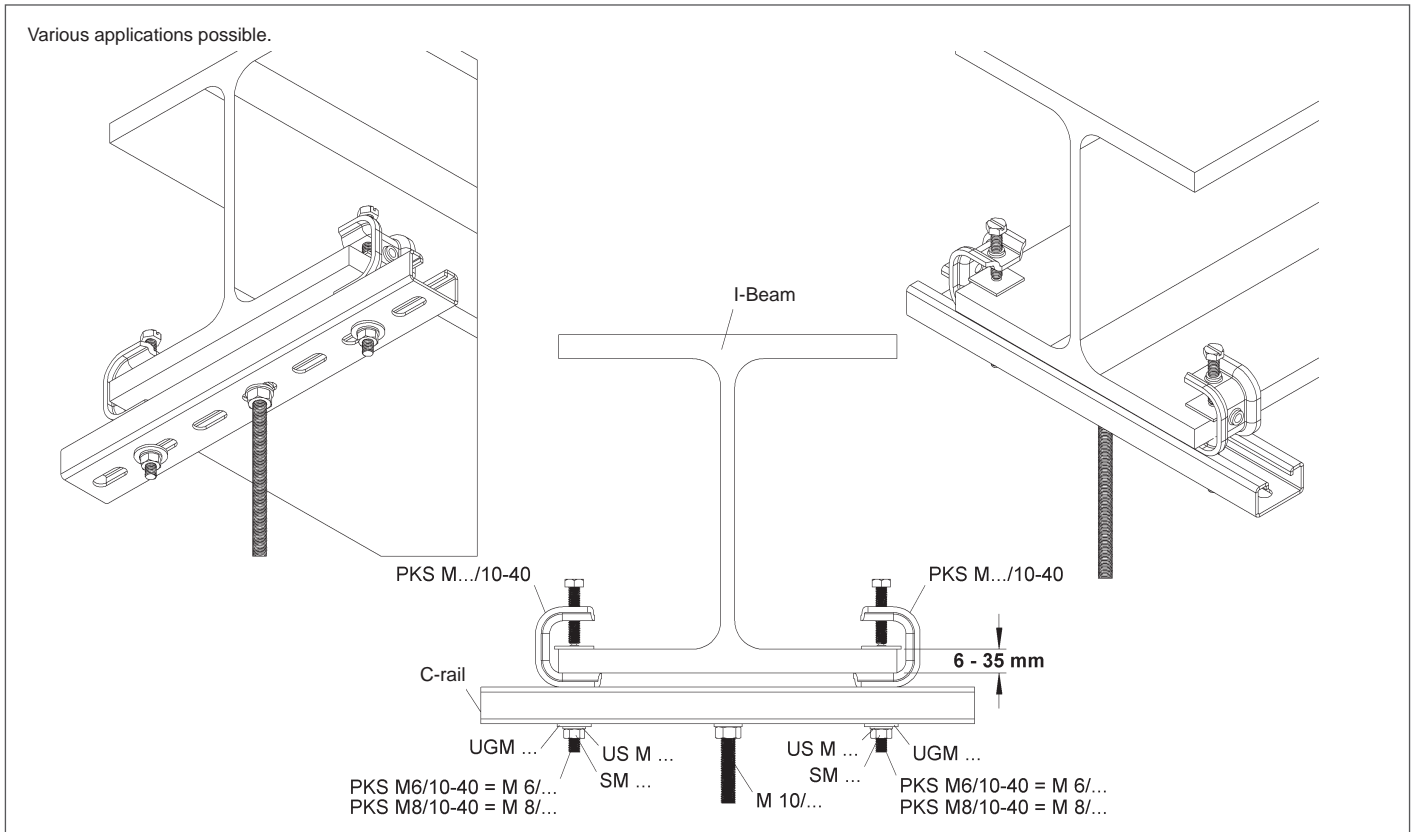

Installation Instructions

MTC... Wire Mesh Tray with Snap Connector

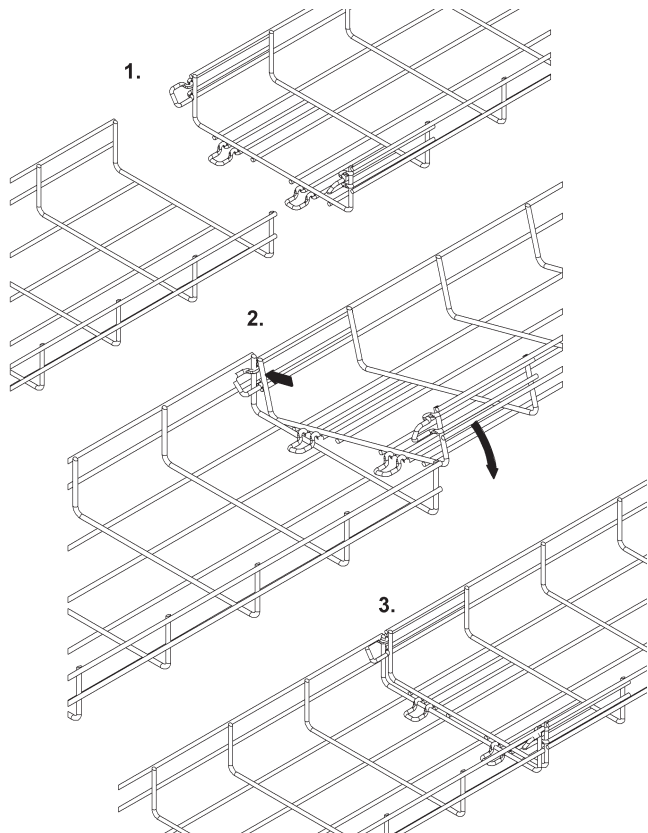

Splice Kit for and MTC... Wire Mesh Tray

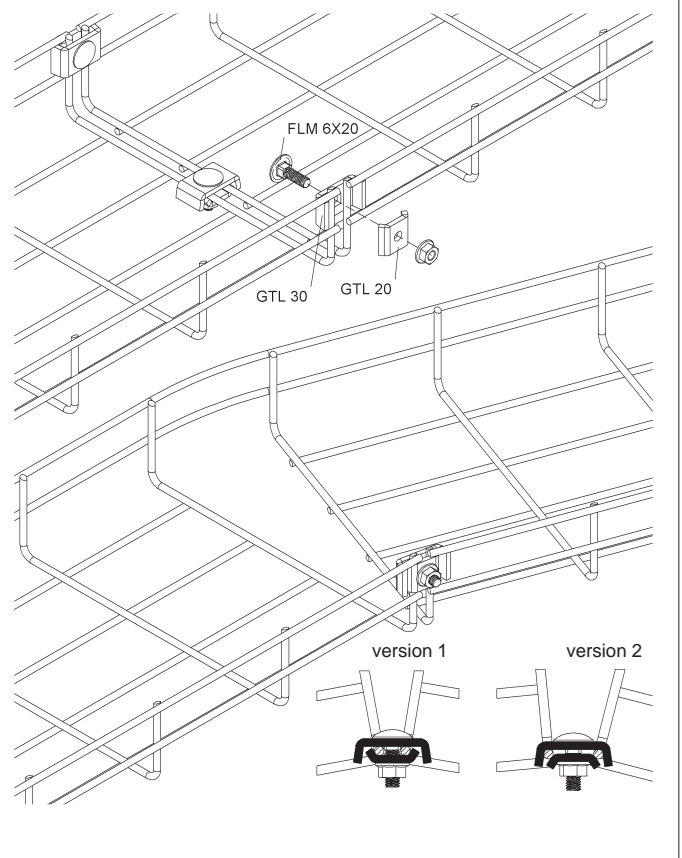

flexible vertical outside elbow

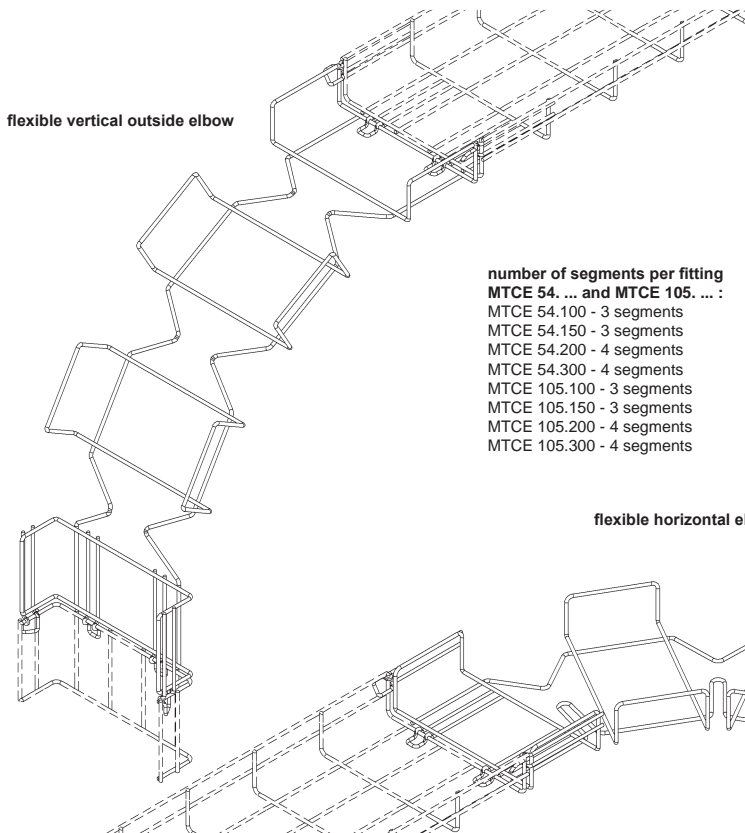

number of segments per fitting
MTCE 54. ... and MTCE 105. ... :
 MTCE 54.100 - 3 segments
 MTCE 54.150 - 3 segments
 MTCE 54.200 - 4 segments
 MTCE 54.300 - 4 segments
 MTCE 105.100 - 3 segments
 MTCE 105.150 - 3 segments
 MTCE 105.200 - 4 segments
 MTCE 105.300 - 4 segments

flexible horizontal elbow

flexible vertical inside elbow

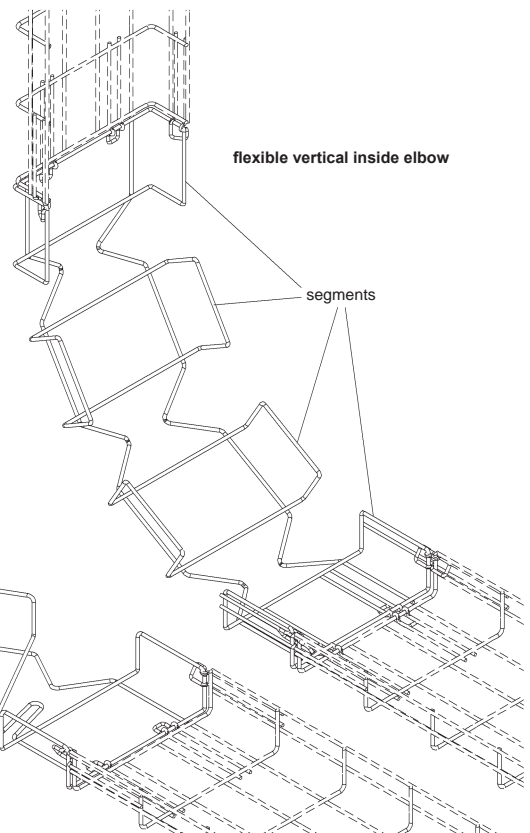

GENERAL INFORMATION

Installation Instructions

Wall Mount Bracket for GR..., GRS... and MTC... Wire Mesh Tray

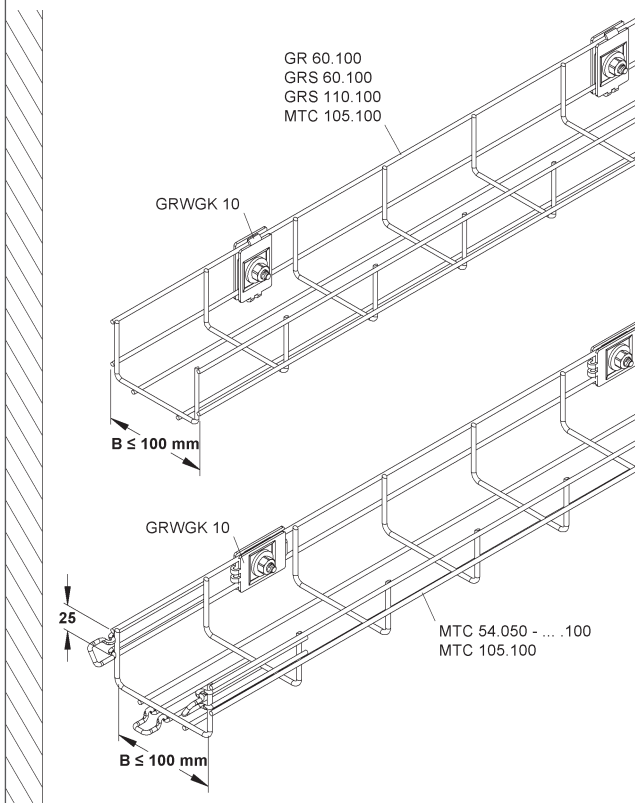

Center Hanger for MTC... Wire Mesh Tray

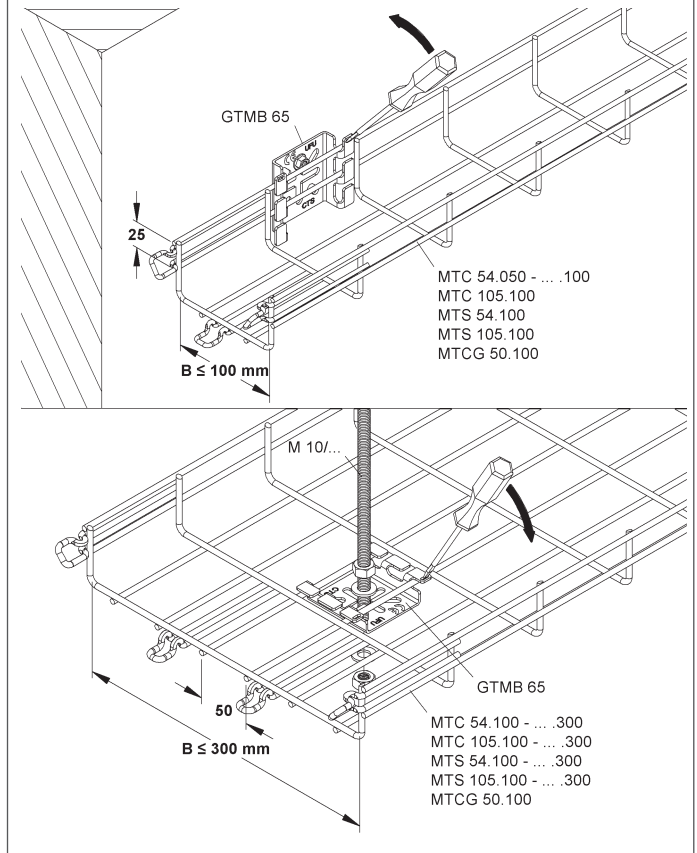

Center Hanger for GR..., GRS... and MTC... Wire Mesh Tray

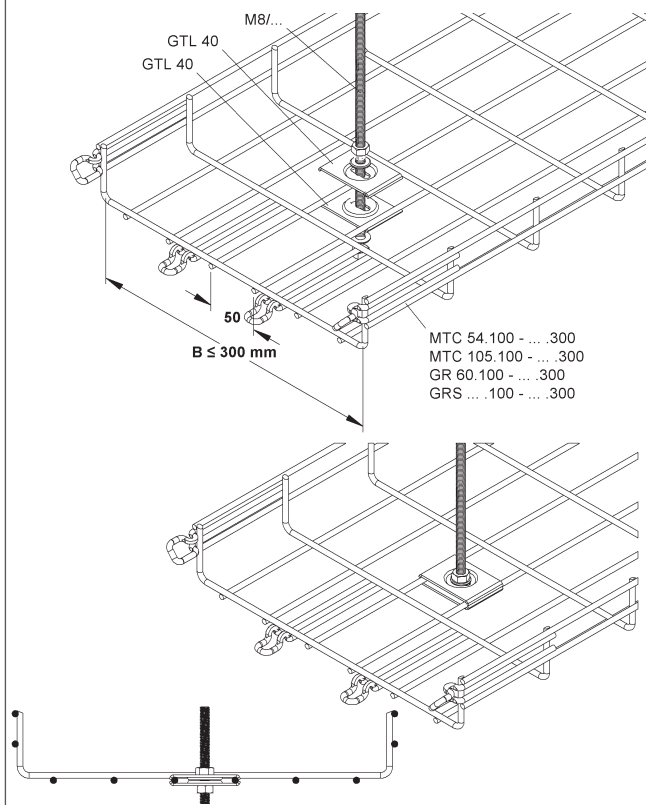

Trapeze Hanger for MTC... Wire Mesh Tray

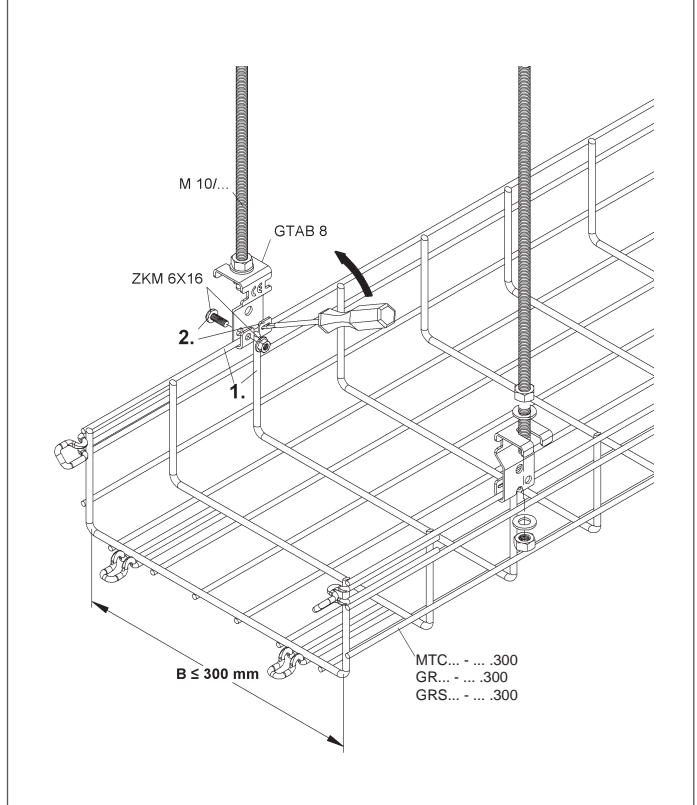

Installation Instructions

C-Hanger and Wall-Mount Bracket for MTC... Wire Mesh Tray

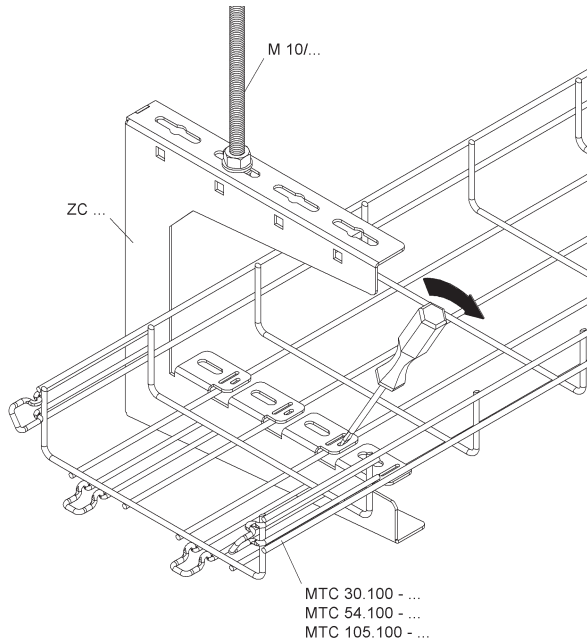

Bracket for GRS... and MTC... Wire Mesh Tray

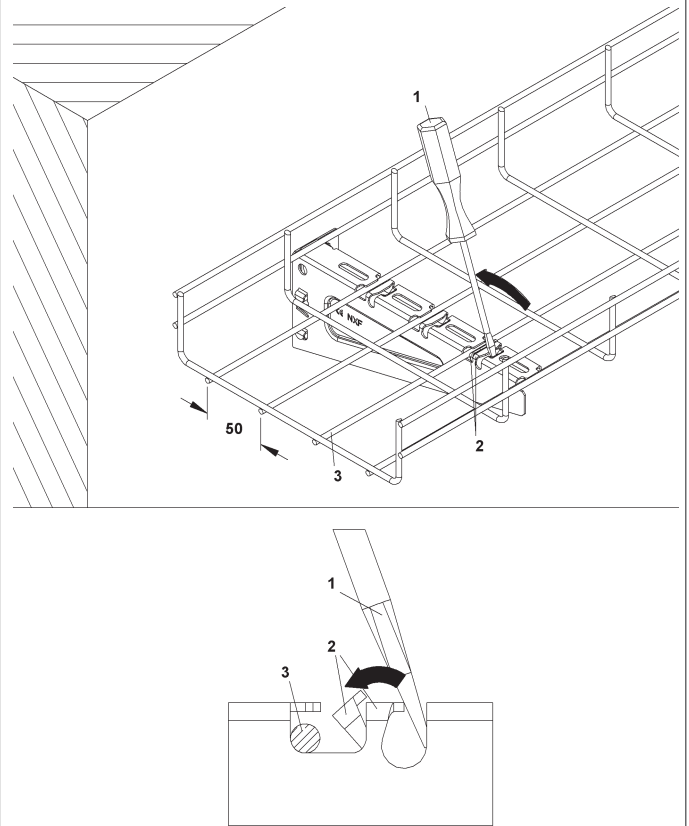

Cable Drop Outs for GR..., GRS... and MTC... Wire Mesh Tray

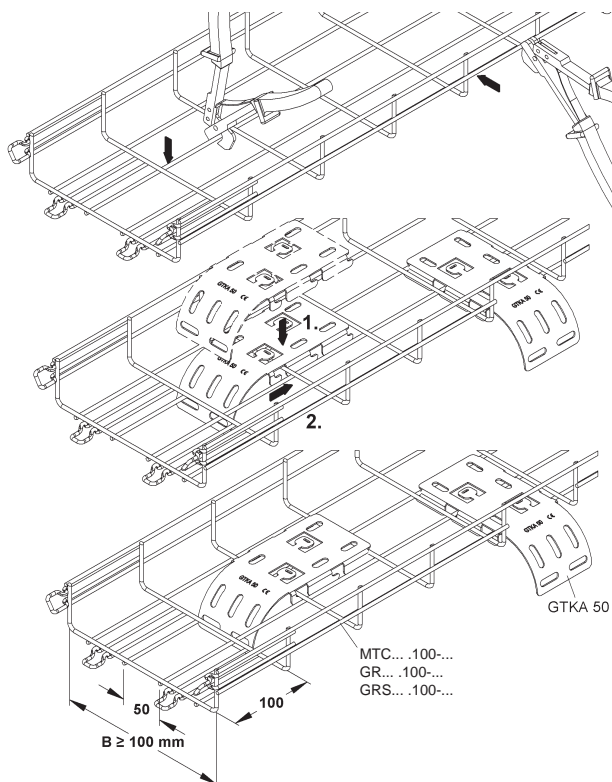

Wire Mesh Mounting Bracket GTWAB 50

1. for direct wall mounting of MTC basket trays in 50 and 100 mm width
2. for bolting MTC basket tray to a wall bracket

direct wall mounting

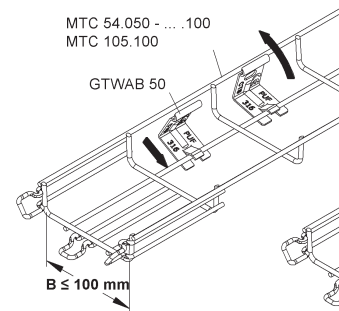

mounting to a bracket

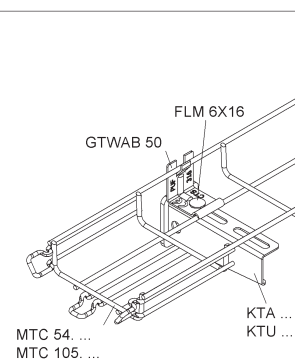
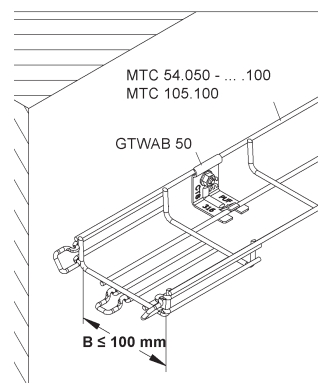
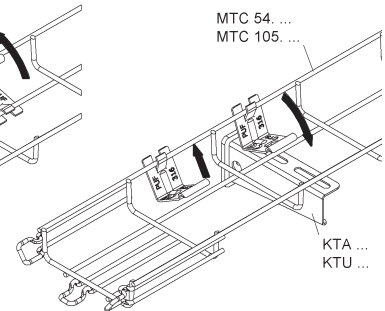

GENERAL INFORMATION

Installation Instructions

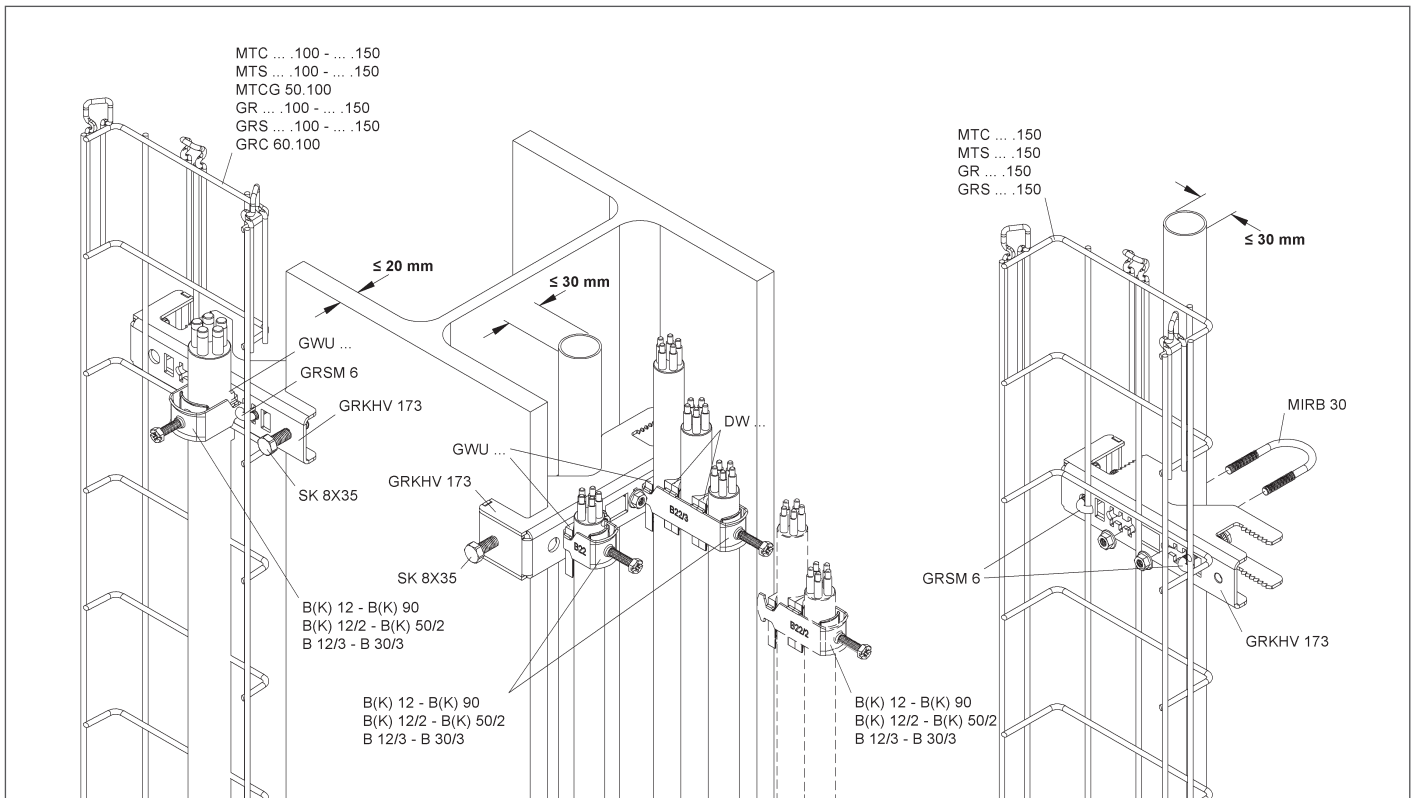
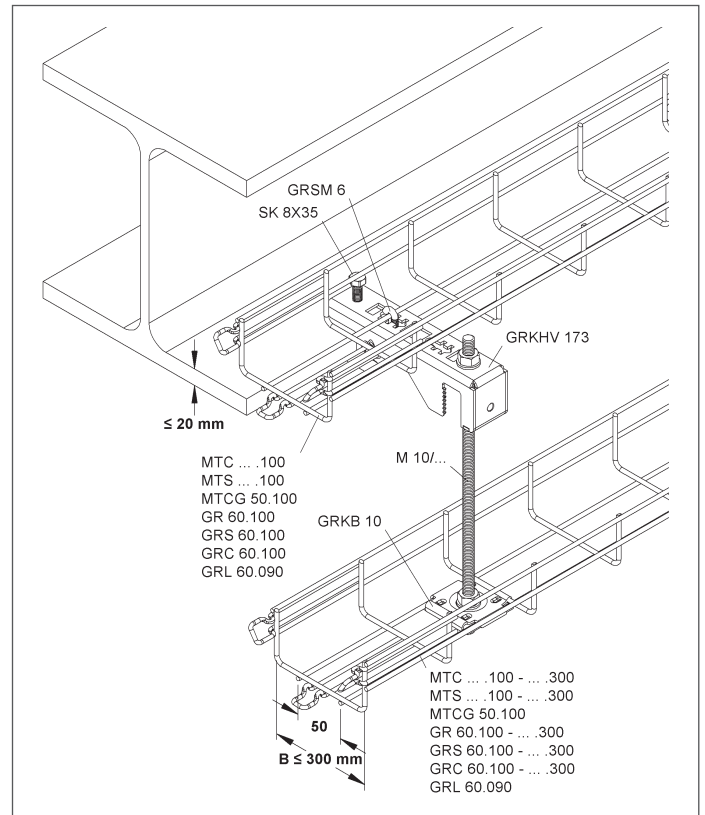
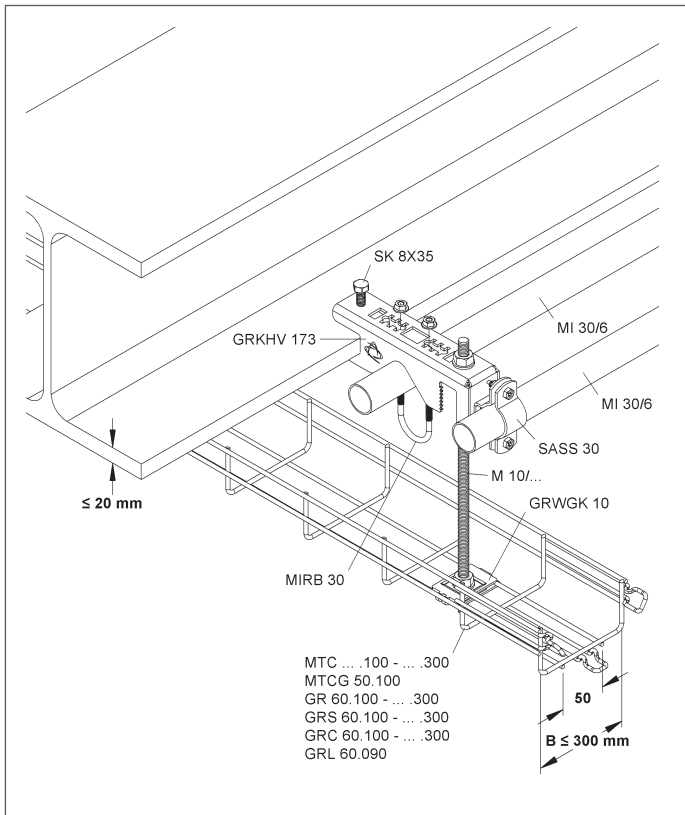

Installation Instructions

GRVS...

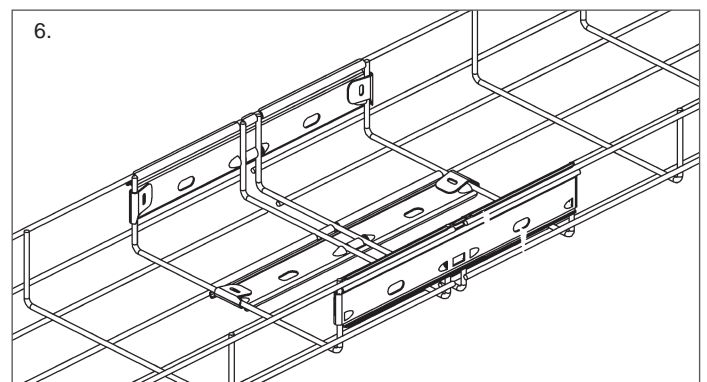
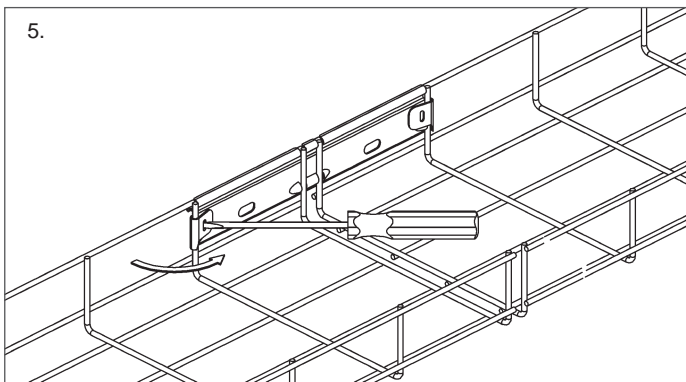
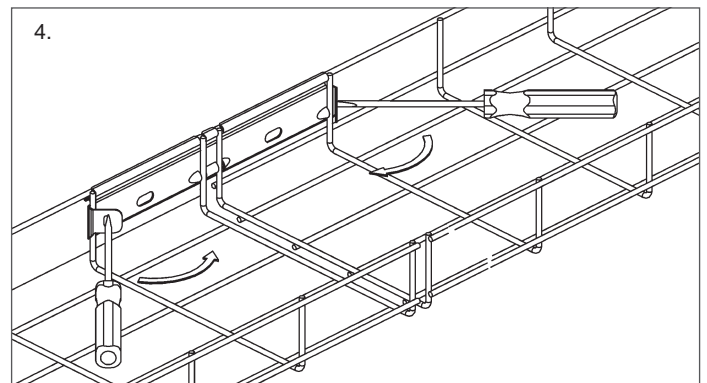
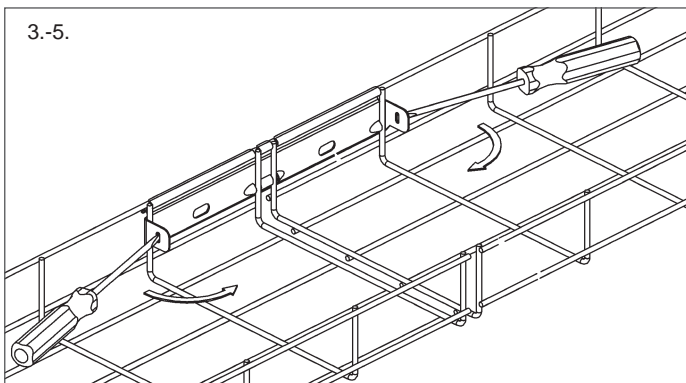
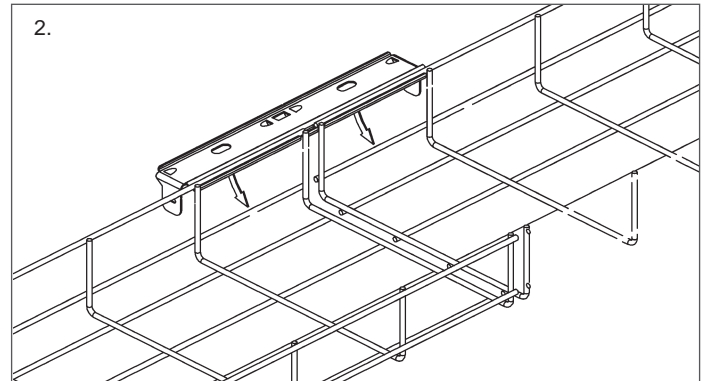
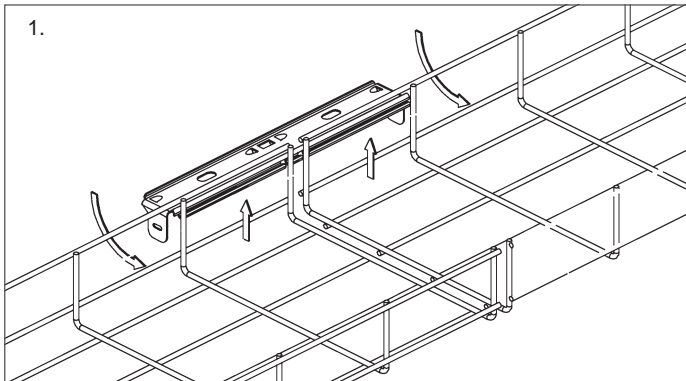

Splice Plate Requirements for Wire Mesh Basket Tray

Wire Mesh Tray Model	Number of Splices	Finish E3 - 304 stainless steel	
		Standard	Boltless
GR 60.060	2	GRHKM 6X15 E3	GRVS 4 E3
GR 60.100	2	GRHKM 6X15 E3	GRVS 4 E3
GR 60.150	2	GRHKM 6X15 E3	GRVS 4 E3
GR 60.200	2	GRHKM 6X15 E3	GRVS 4 E3
GR 60.300	3	GRHKM 6X15 E3	GRVS 4 E3
GRS 60.100	2	GRHKM 6X15 E3	GRVS 5 E3
GRS 60.150	2	GRHKM 6X15 E3	GRVS 5 E3
GRS 60.200	2	GRHKM 6X15 E3	GRVS 5 E3
GRS 60.300	3	GRHKM 6X15 E3	GRVS 5 E3
GRS 60.400	3	GRHKM 6X15 E3	GRVS 5 E3
GRS 110.100	3	GRHKM 6X15 E3	GRVS 5 E3
GRS 110.200	4	GRHKM 6X15 E3	GRVS 5 E3
GRS 110.300	4	GRHKM 6X15 E3	GRVS 5 E3
GRS 110.400	4	GRHKM 6X15 E3	GRVS 5 E3

Two splices have to be installed on or close to the top lengthwire.
The third and fourth splice has to be uniformly distributed in the bottom section of the tray.

GENERAL INFORMATION

Installation Instructions

MTCSC 22 E2

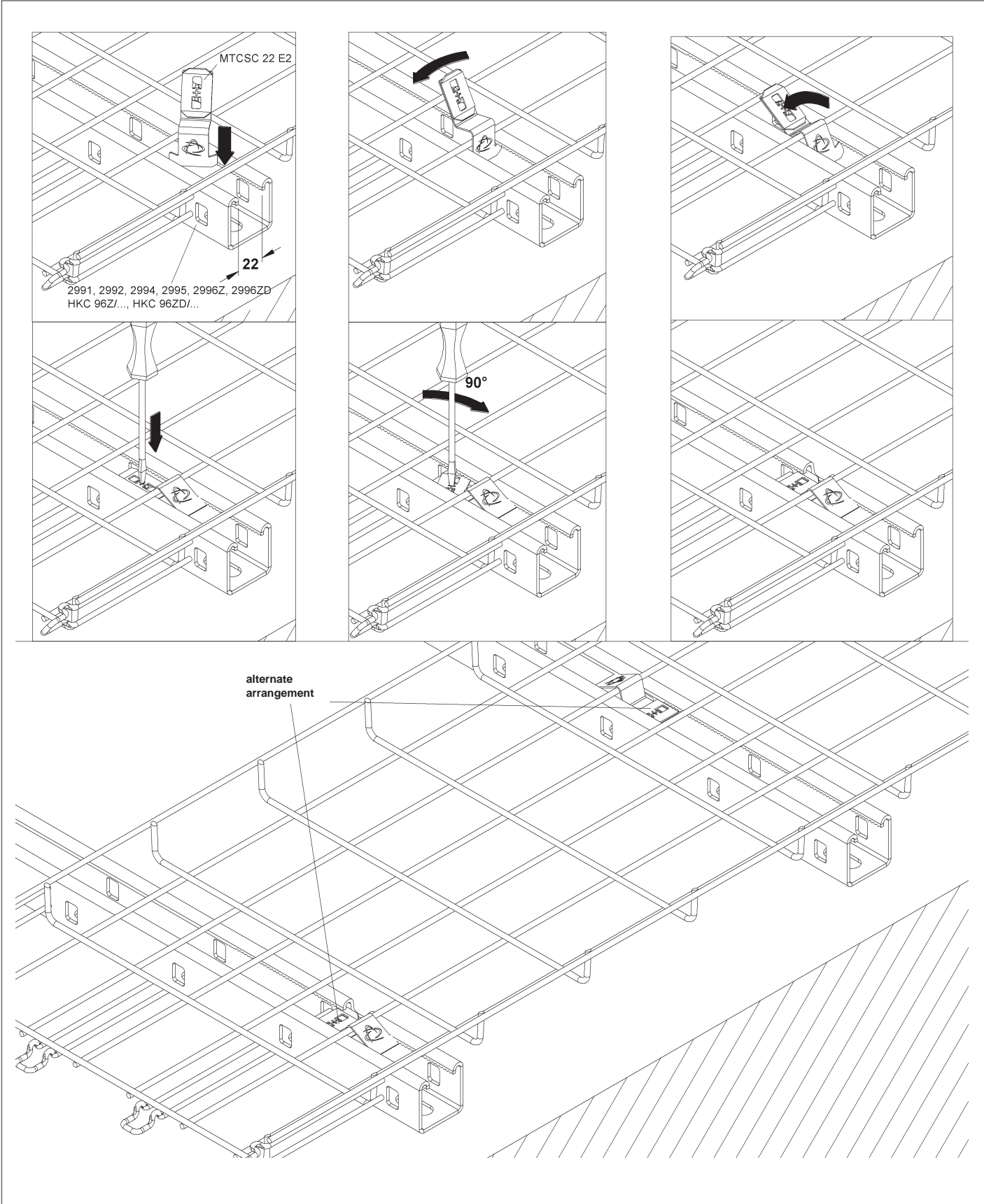

Installation Instructions

MTCDC 24 E2

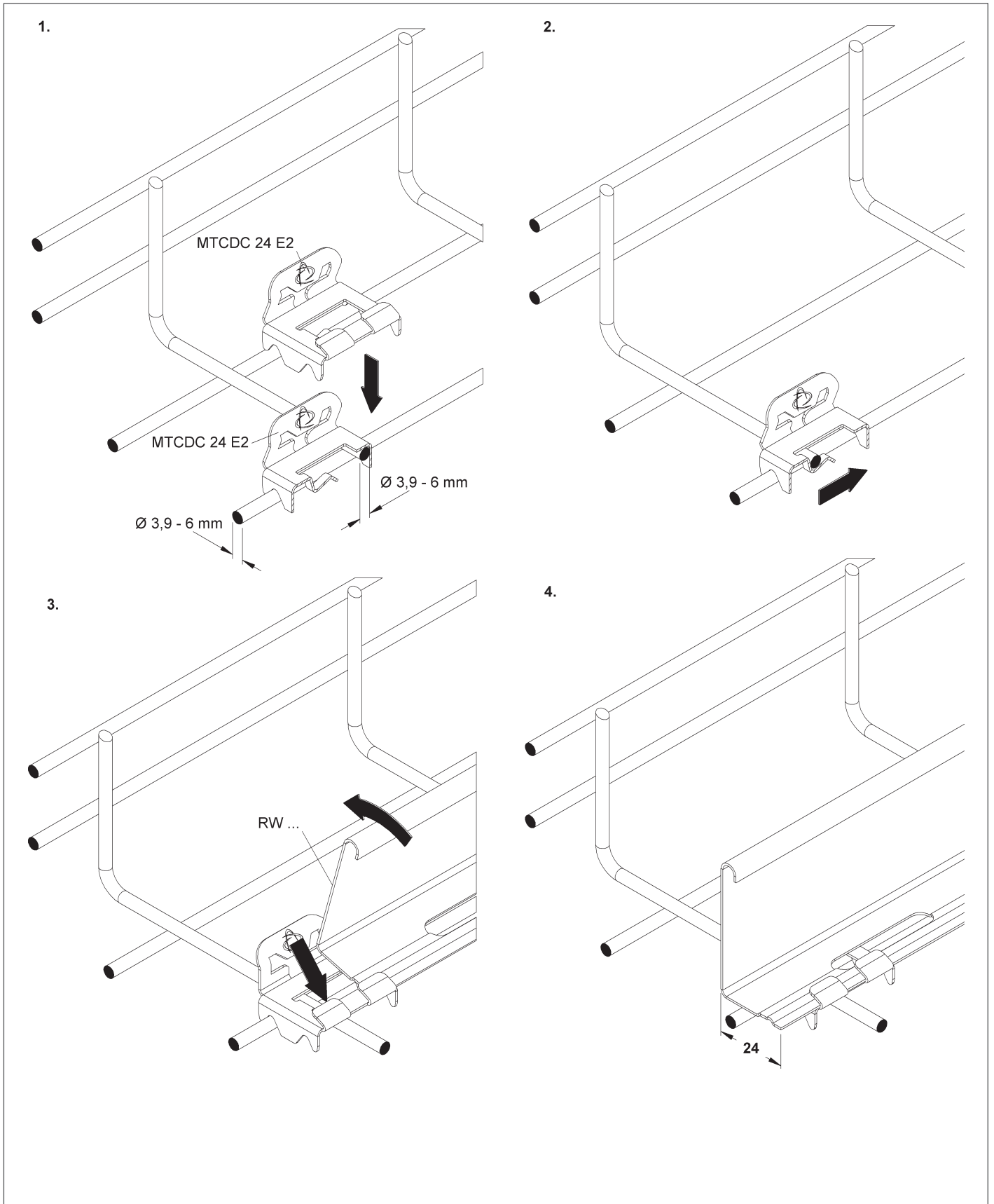

GENERAL INFORMATION

How to Build Wire Mesh Tray Fittings

Large Radius Elbows

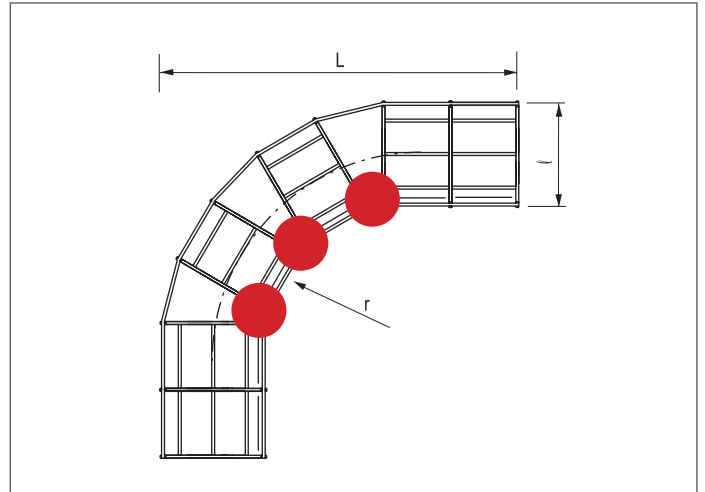
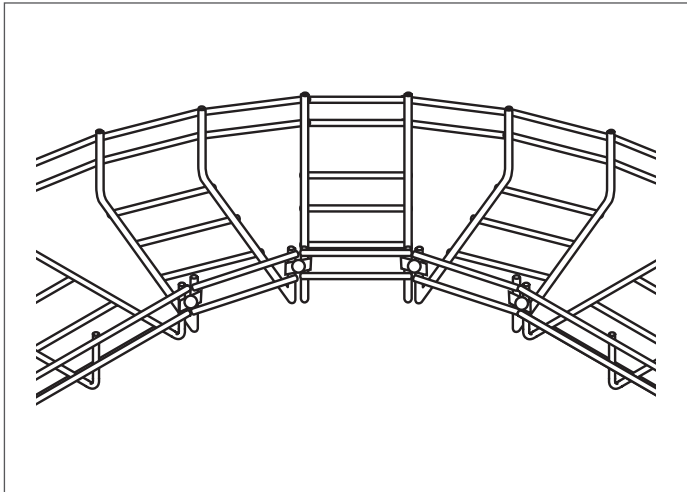

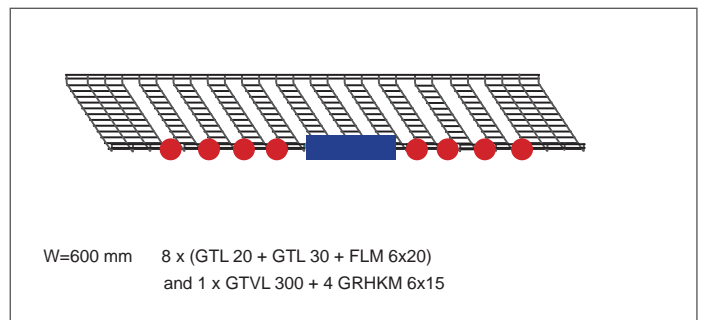
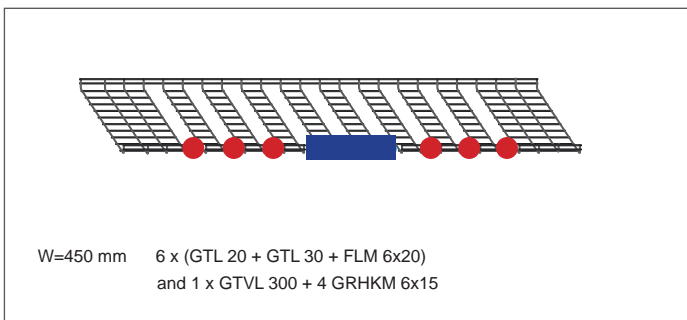
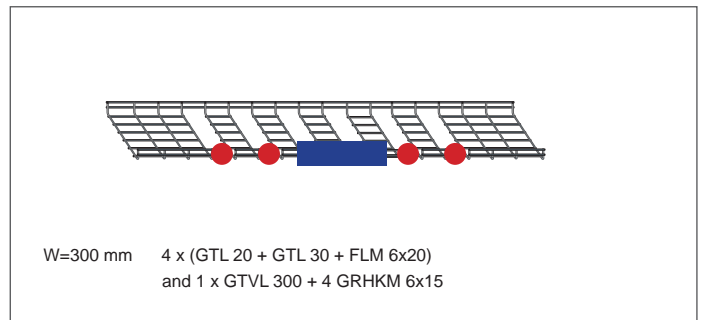
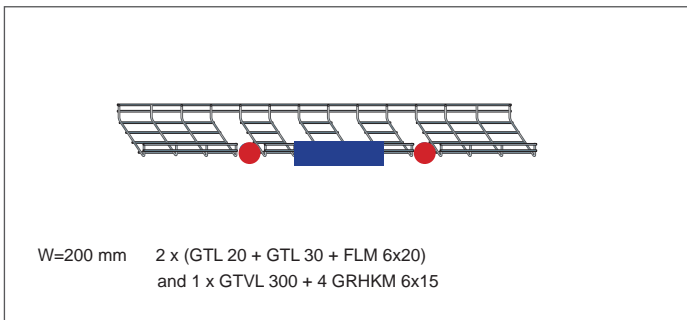
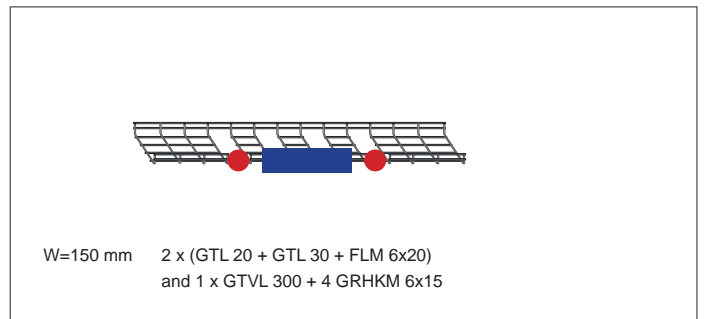
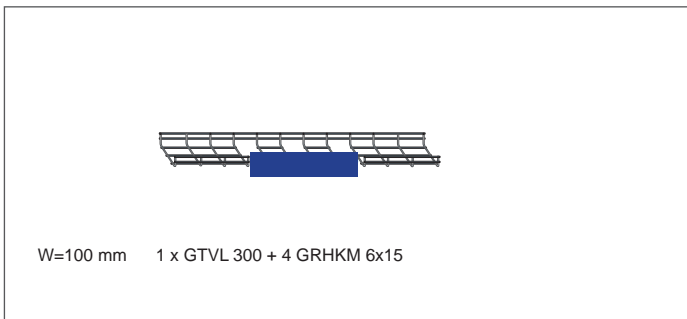

● stands for (GTL 20 + GTL 30 + FLM 6x20)
 ■ stands for 1 x GTVL 300 + 4 GRHKM 6x15

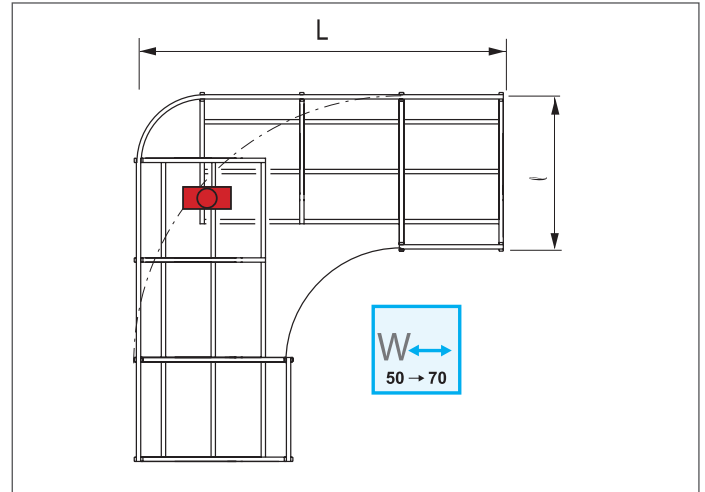
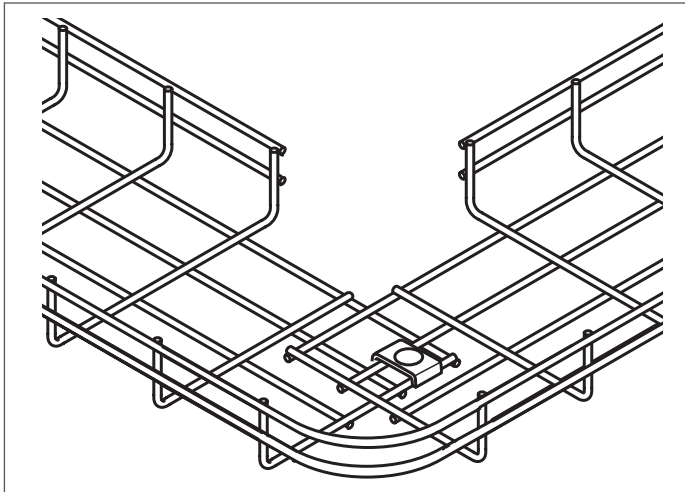

How to Build Wire Mesh Tray Fittings

Small Radius Elbows



 stands for (GTL 20 + GTL 30 + FLM 6x20)

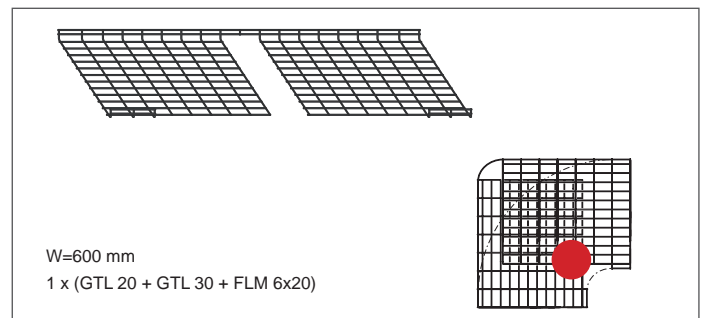
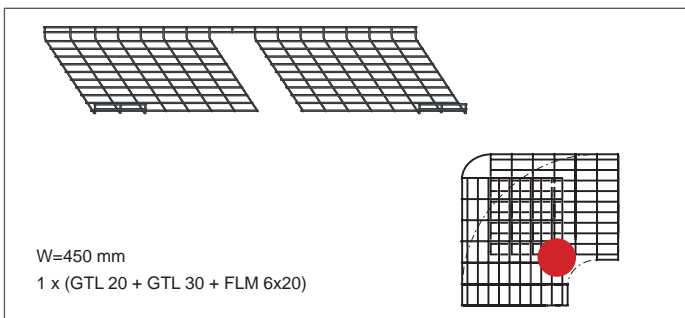
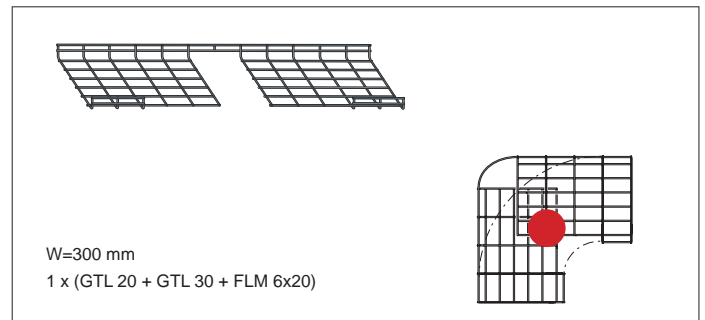
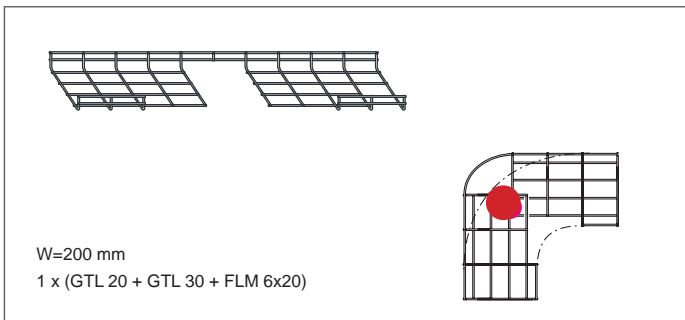
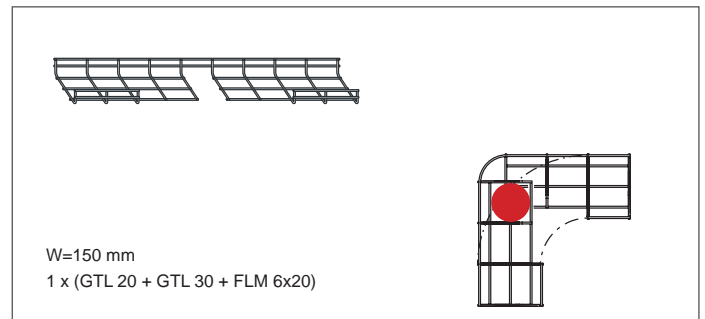
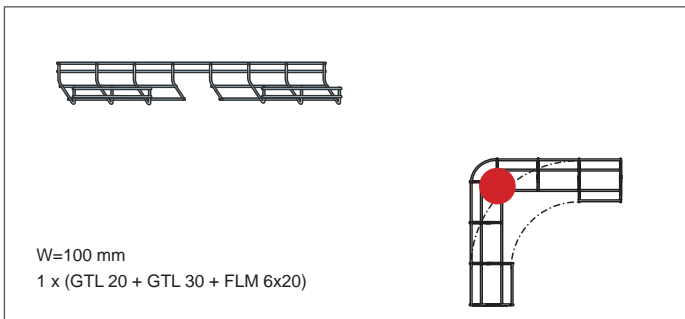

GENERAL INFORMATION

How to Build Wire Mesh Tray Fittings

Angular Tees

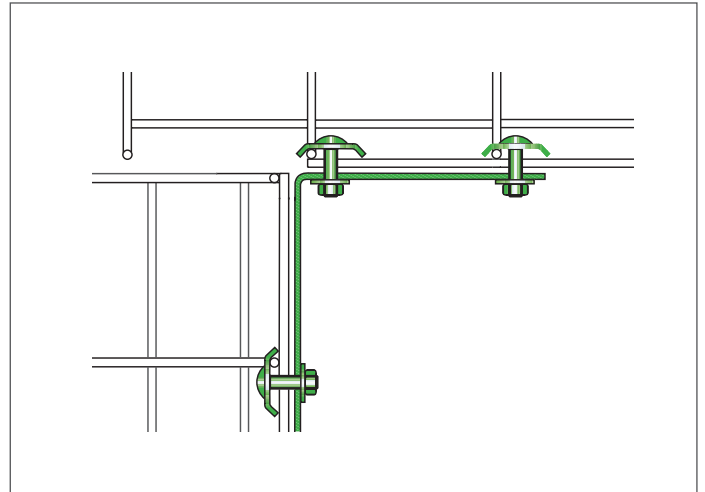
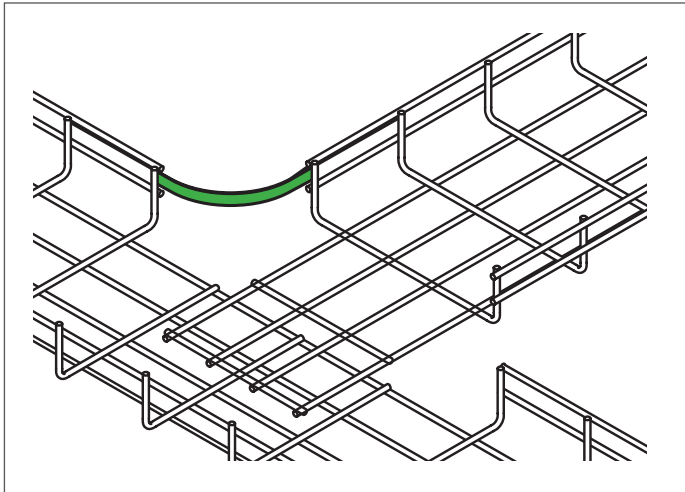

 stands for GRHKM 6x15 or GRSM 6 fastener location

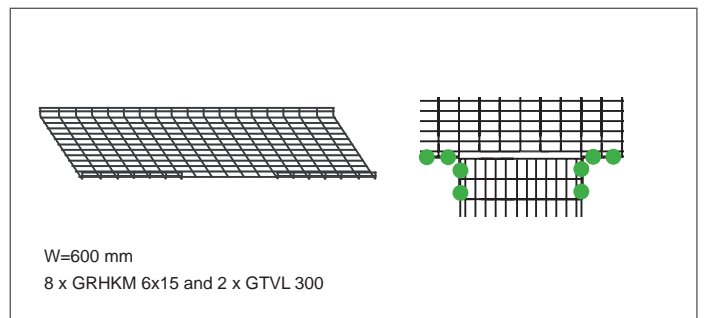
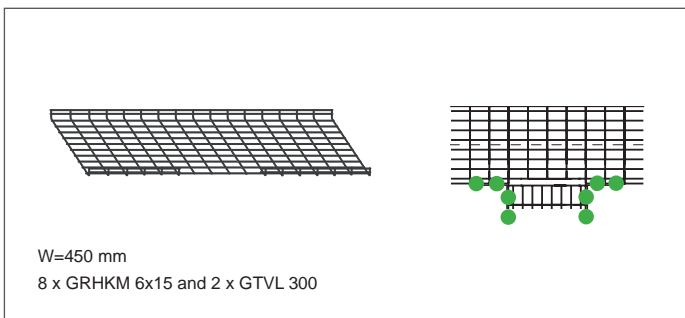
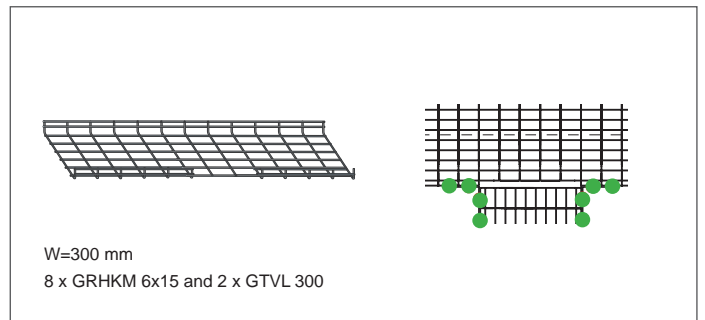
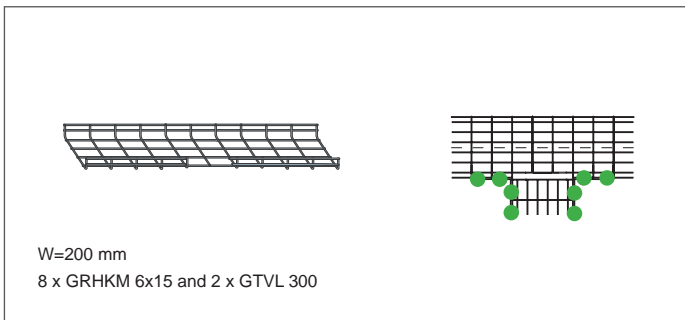
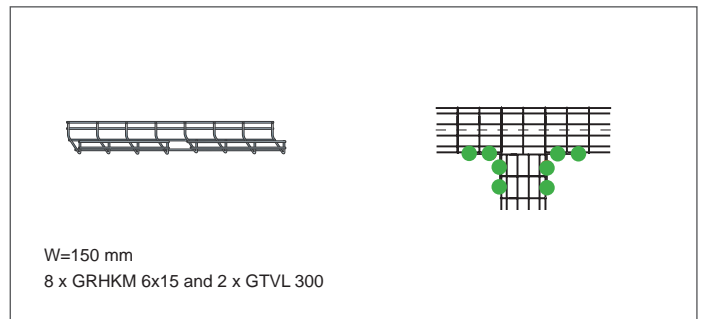
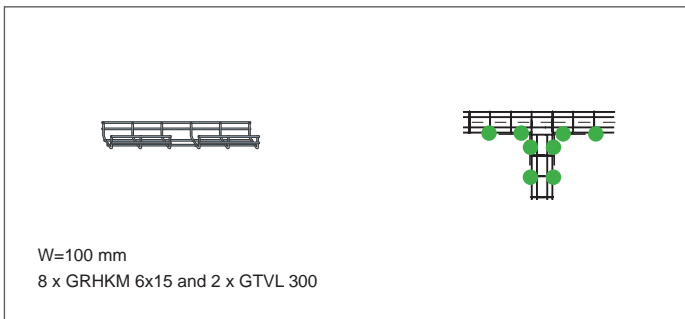

Installation Instructions

RDHF 9 E2

Installation Instructions

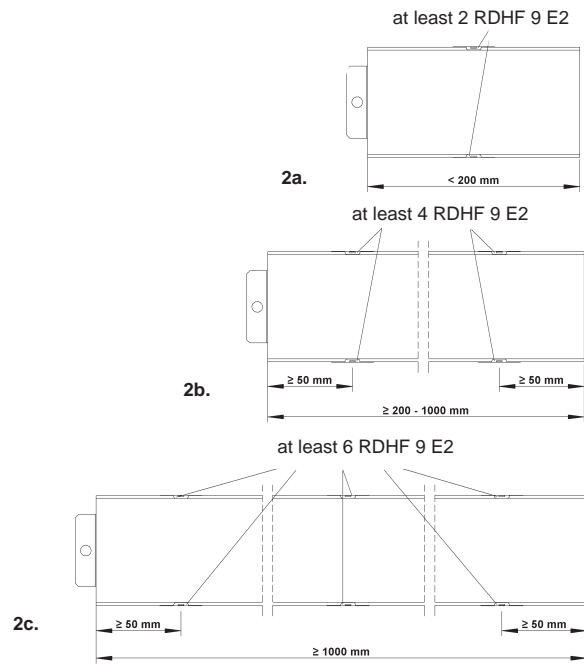
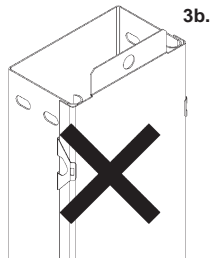
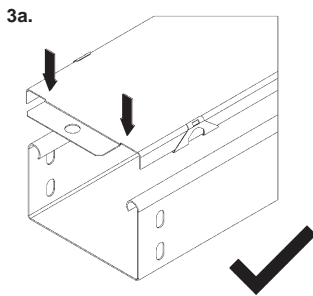
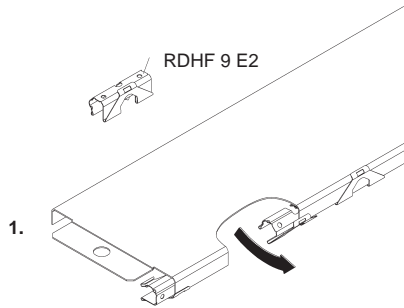

Dismantling Instructions

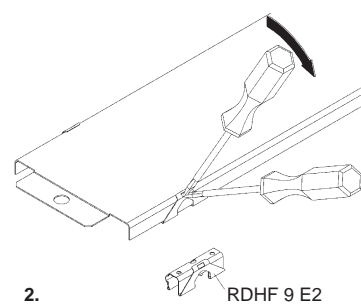
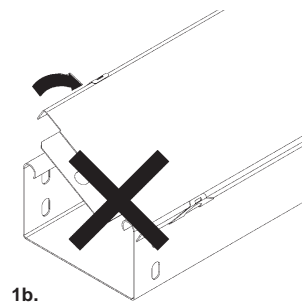
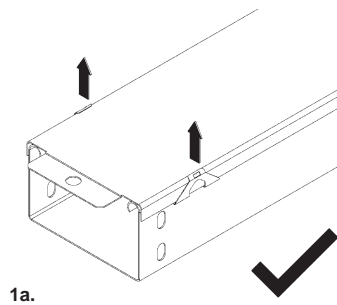

GENERAL INFORMATION

Installation Instructions

Extension Horizontal Tee RTAK... , RTA...

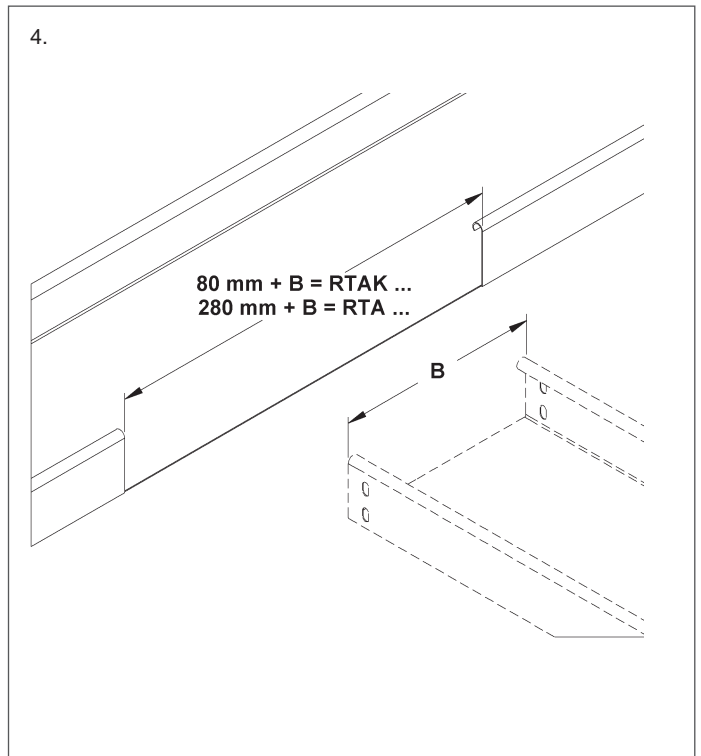
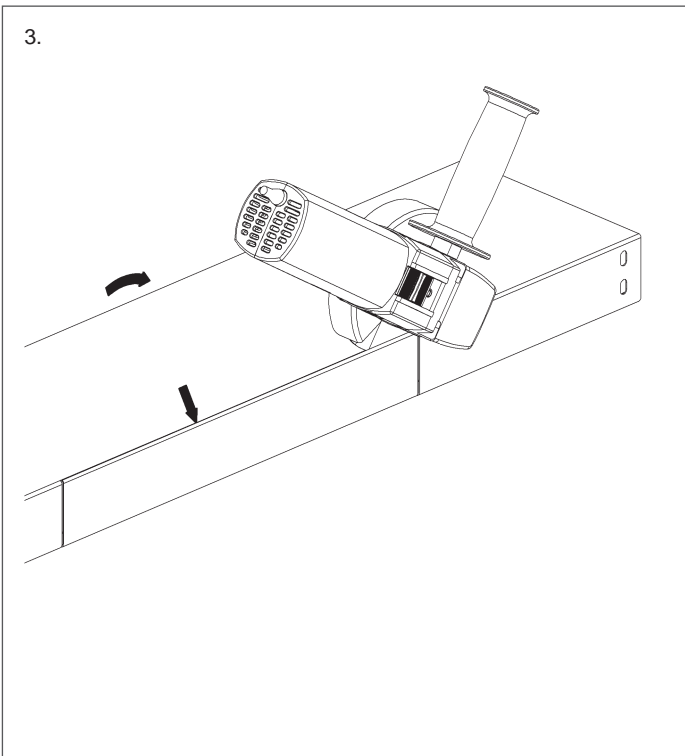
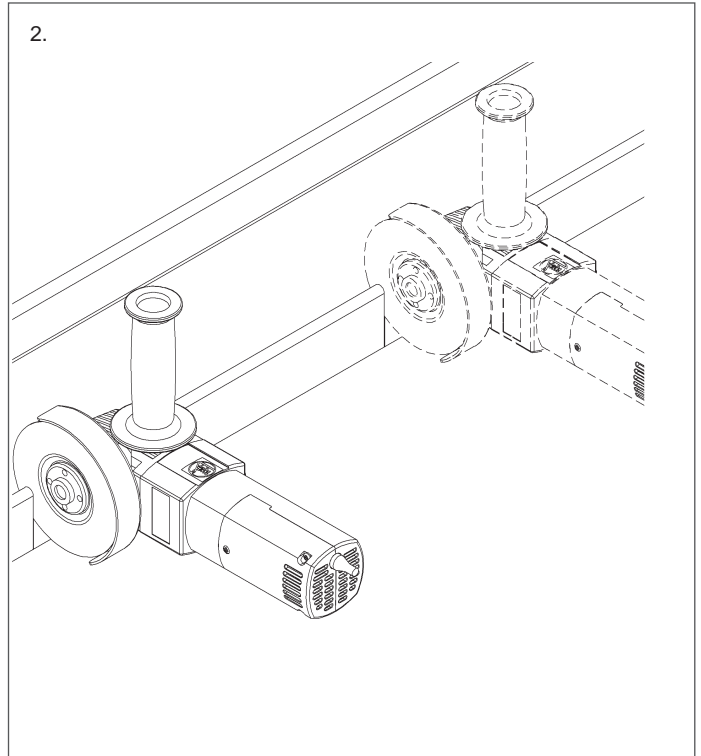
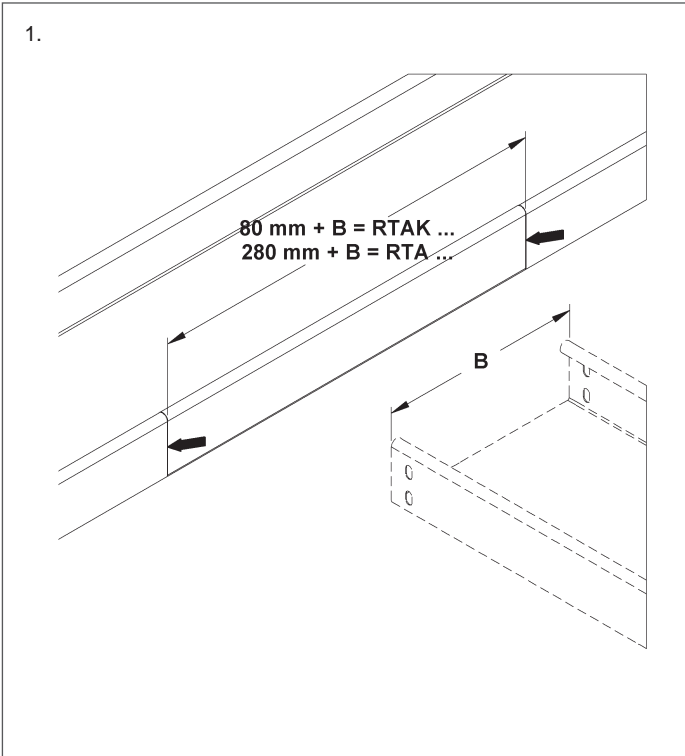

Installation Instructions

Extension Horizontal Tee RTAK... , RTA...

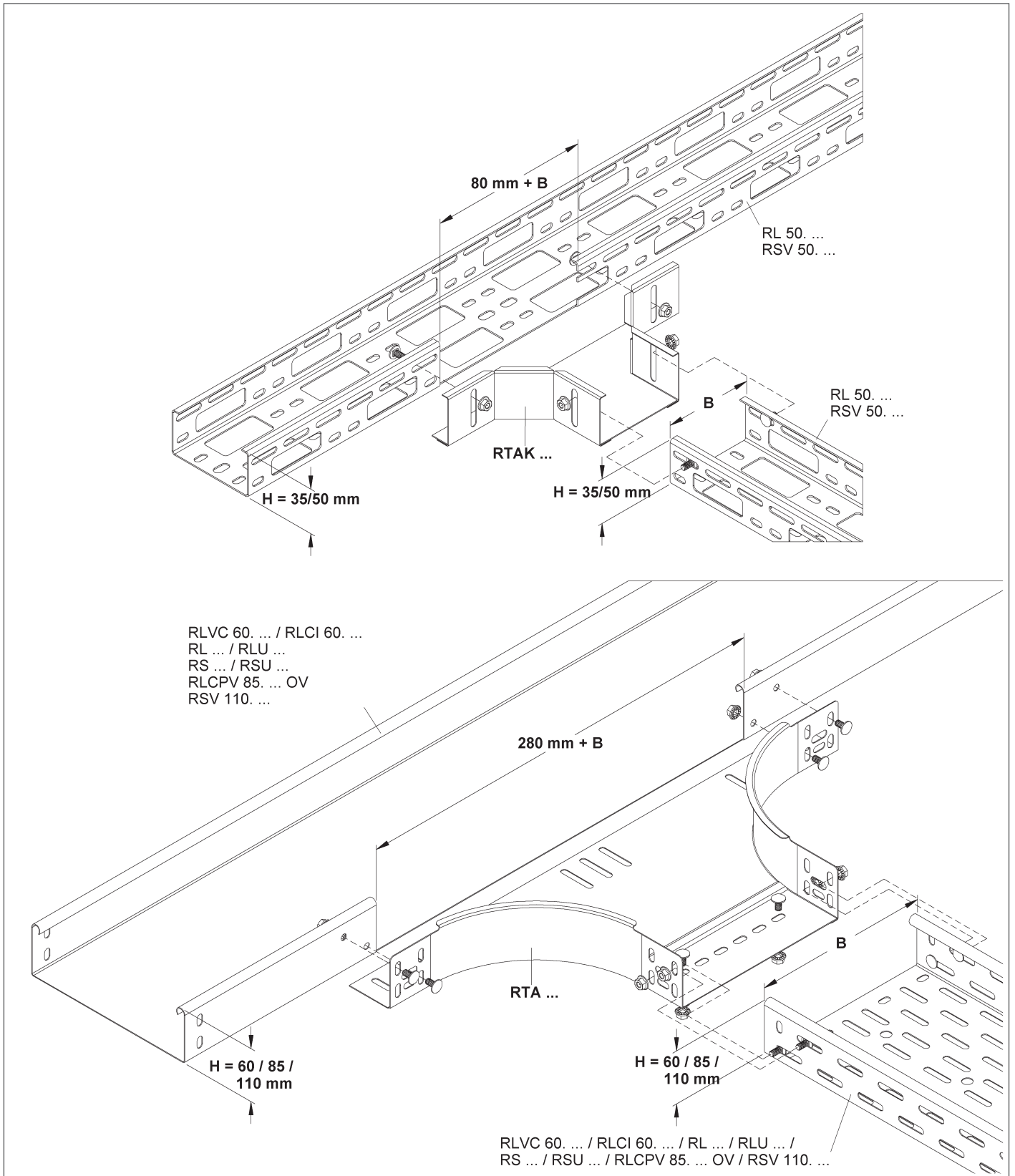

GENERAL INFORMATION

Installation Instructions

Horizontal Elbow Building Block REK...

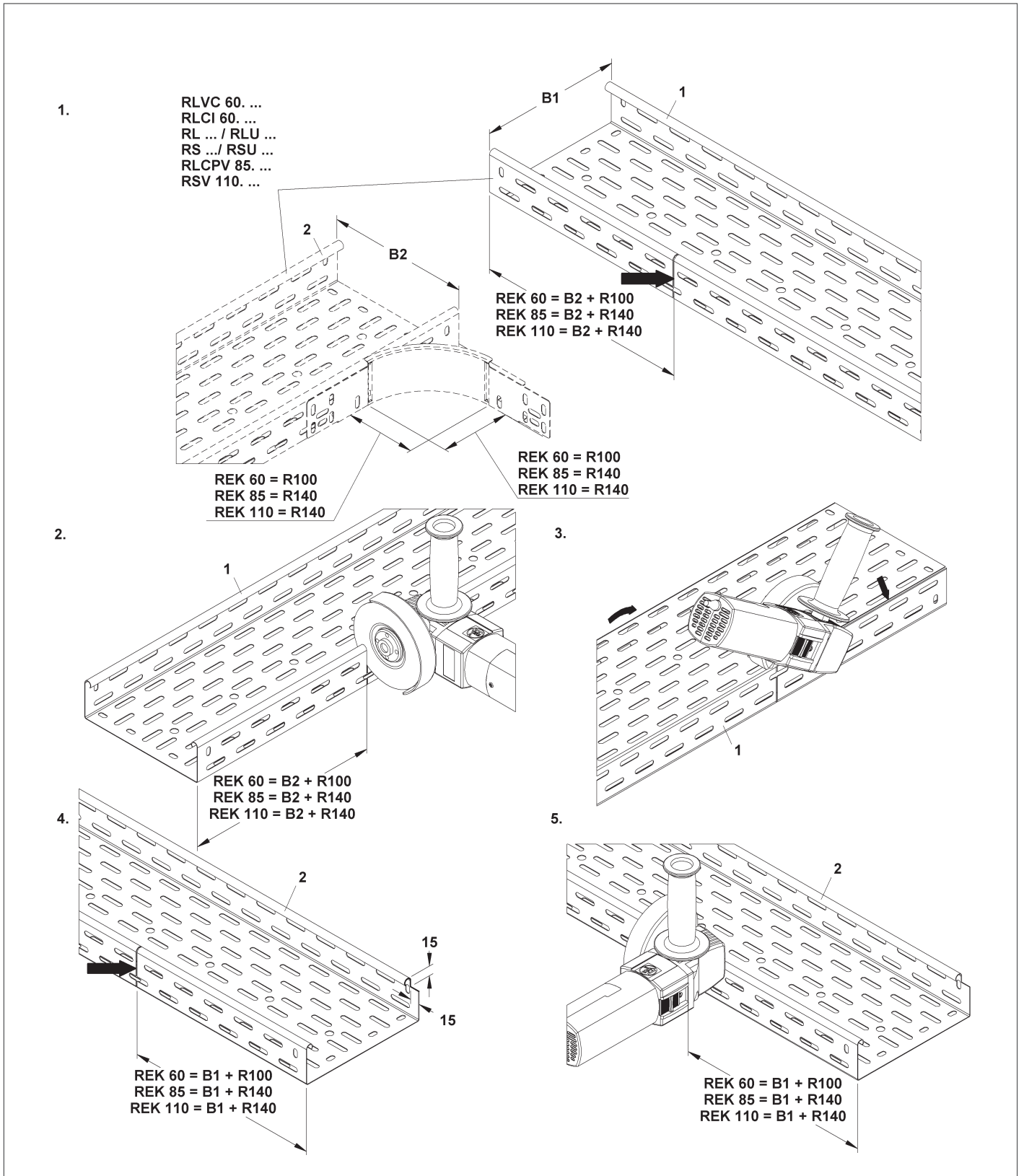

Installation Instructions

Horizontal Elbow Building Block REK...

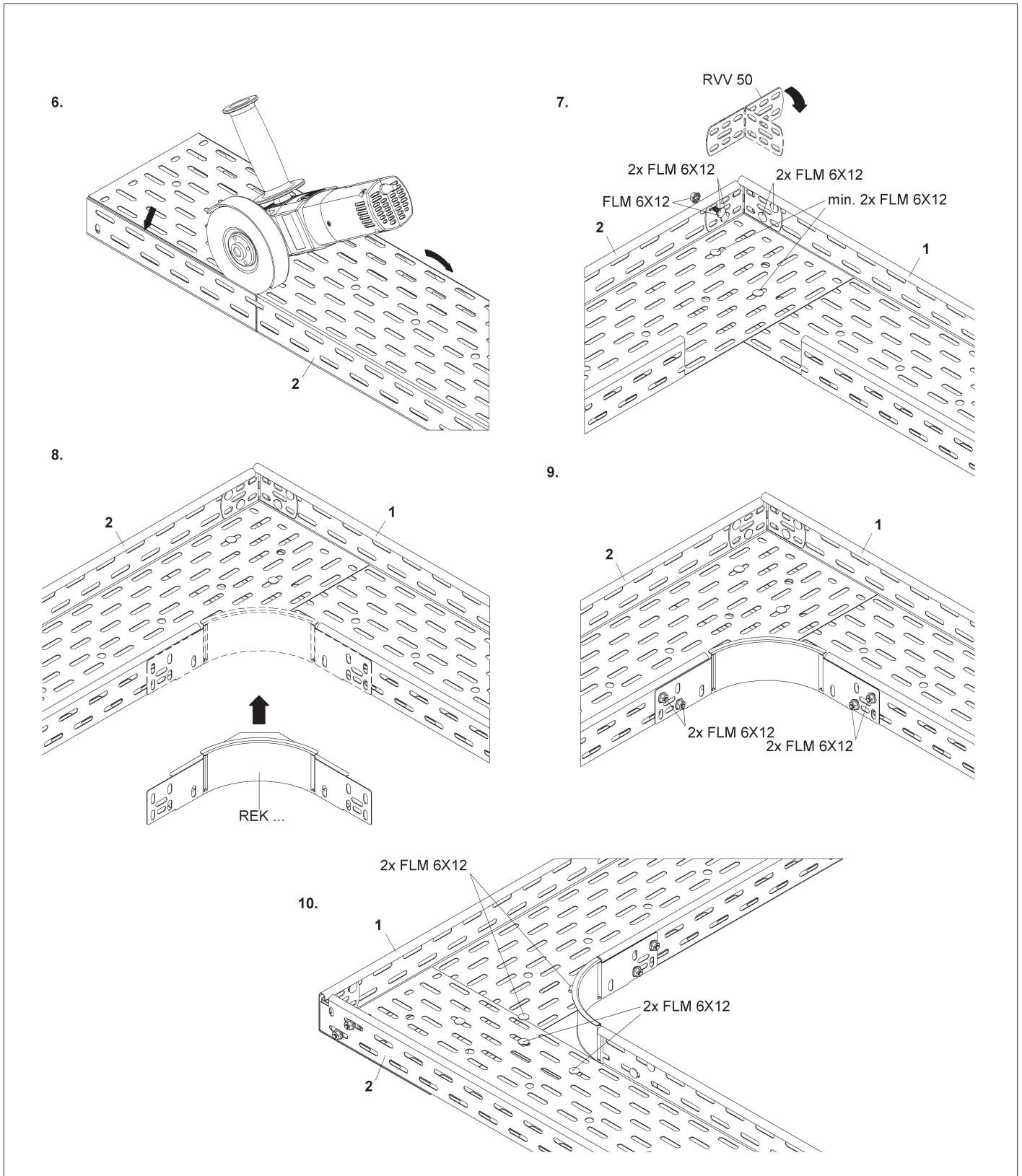

GENERAL INFORMATION

Installation Instructions

RTL... Vertical Tee Down, lengthwise

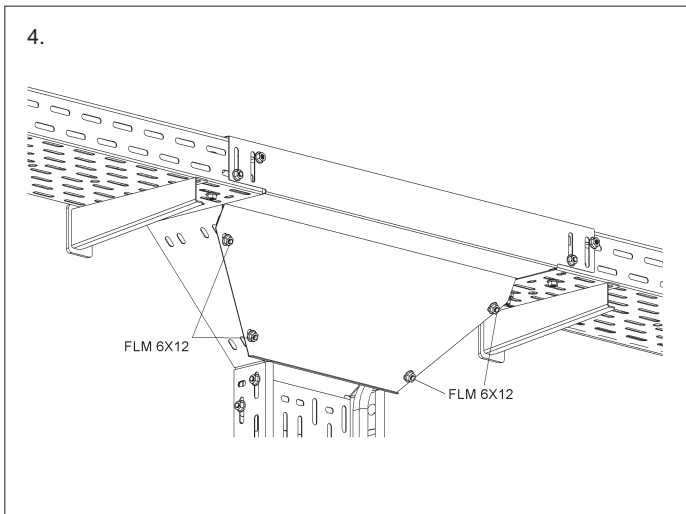
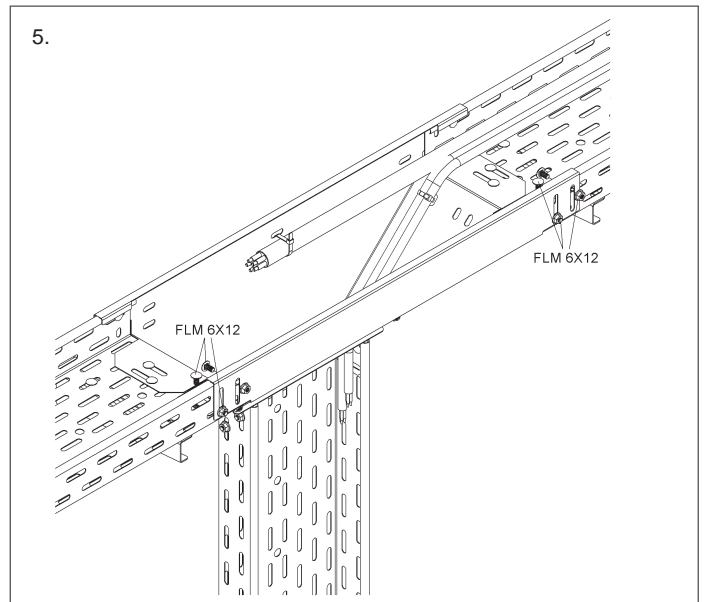
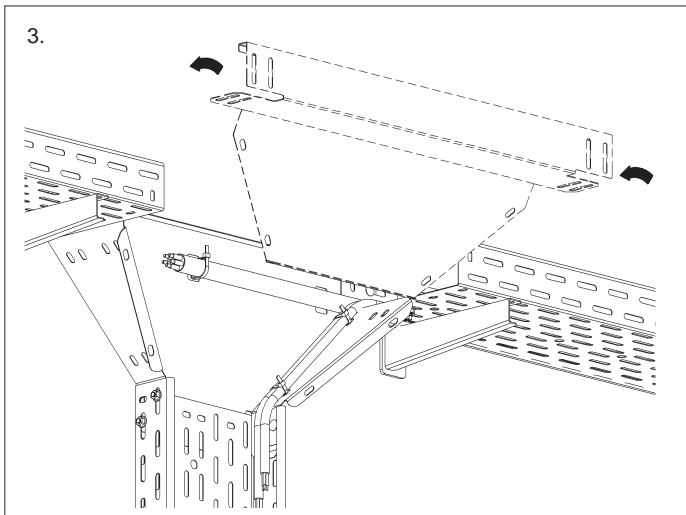
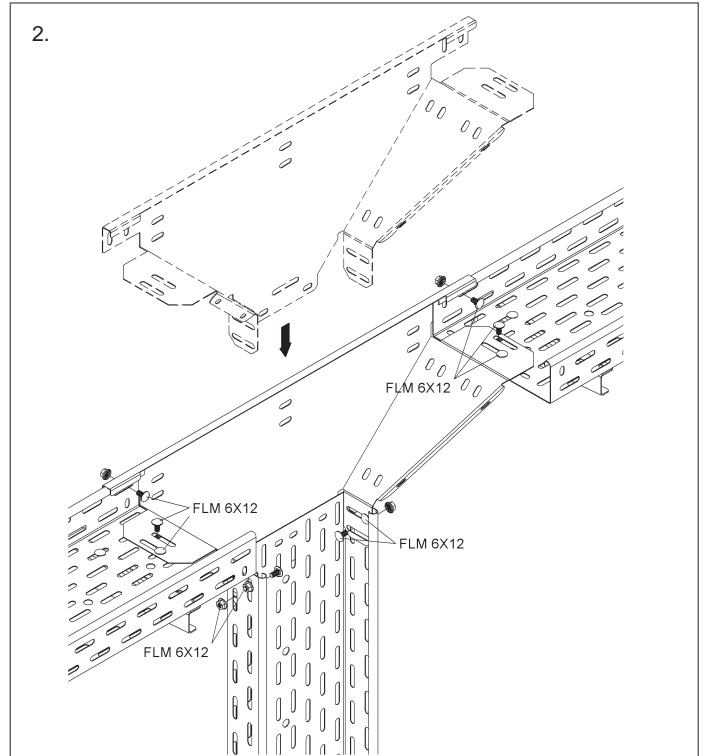
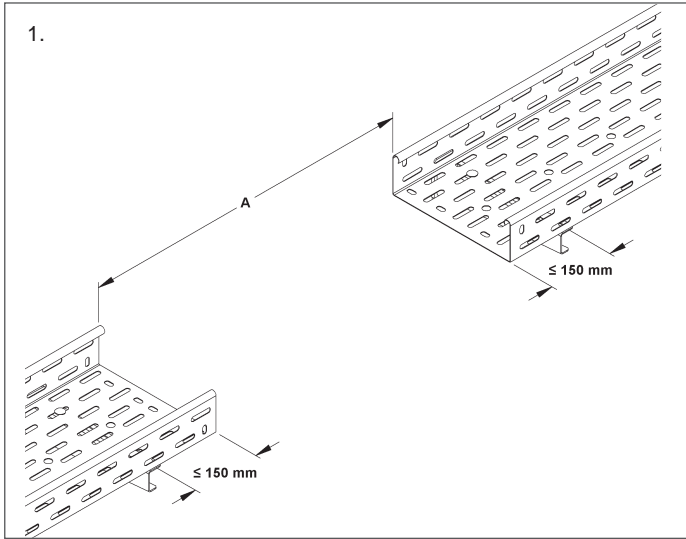

Installation Instructions

RW...

Installing barrier strips to wire mesh or cable tray

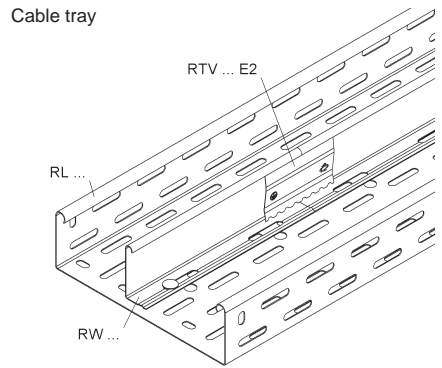
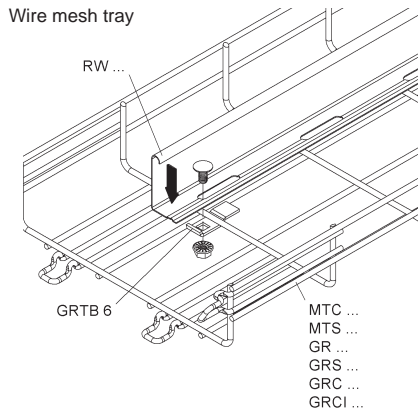

RTV...

Installing barrier strip splice plates

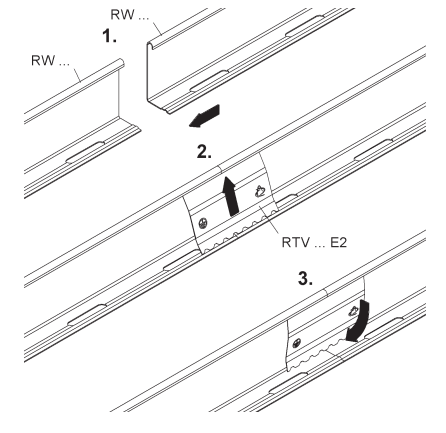

Installing barrier strips to cable ladders in **S** or **F** finish

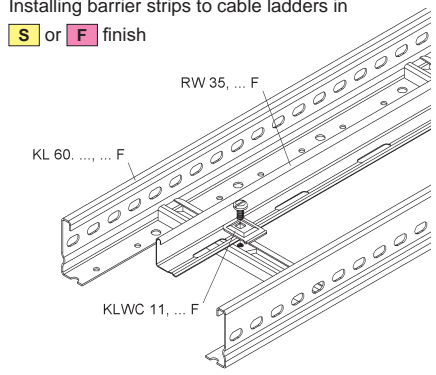

Stainless steel cable ladders

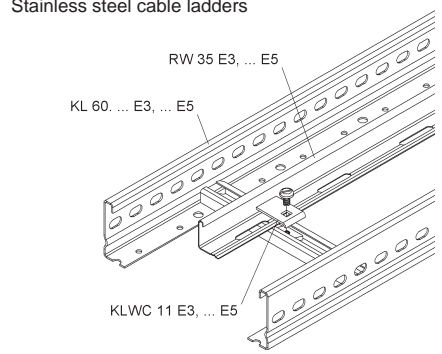

Installing barrier strips to long span tray or ladder

Long Span Tray (use one KLWC 16... on every second rung)

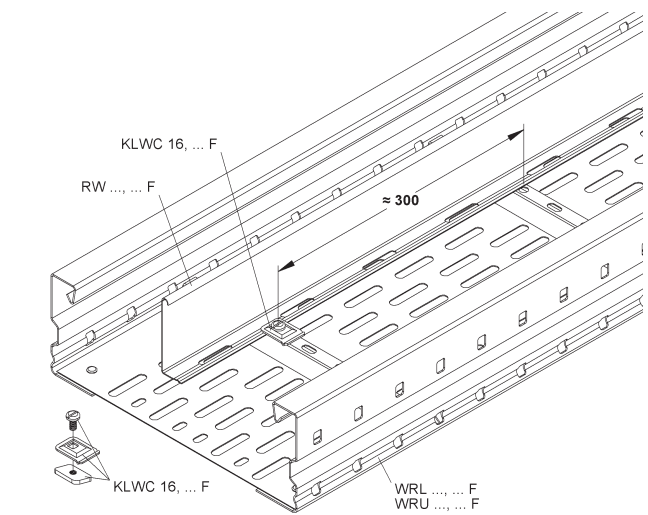

Long Span Ladder (use one KLWC 16 E3 on every second rung) Please preassemble the KLWC 16 E3 before inserting the sliding nut into the rung.

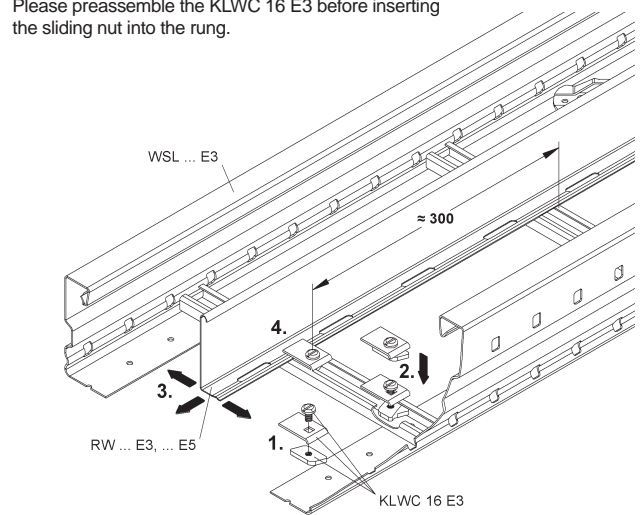

GENERAL INFORMATION

Installation Instructions

RSUVKS...

Forming a tee joint with the RSUVKS... splice plate

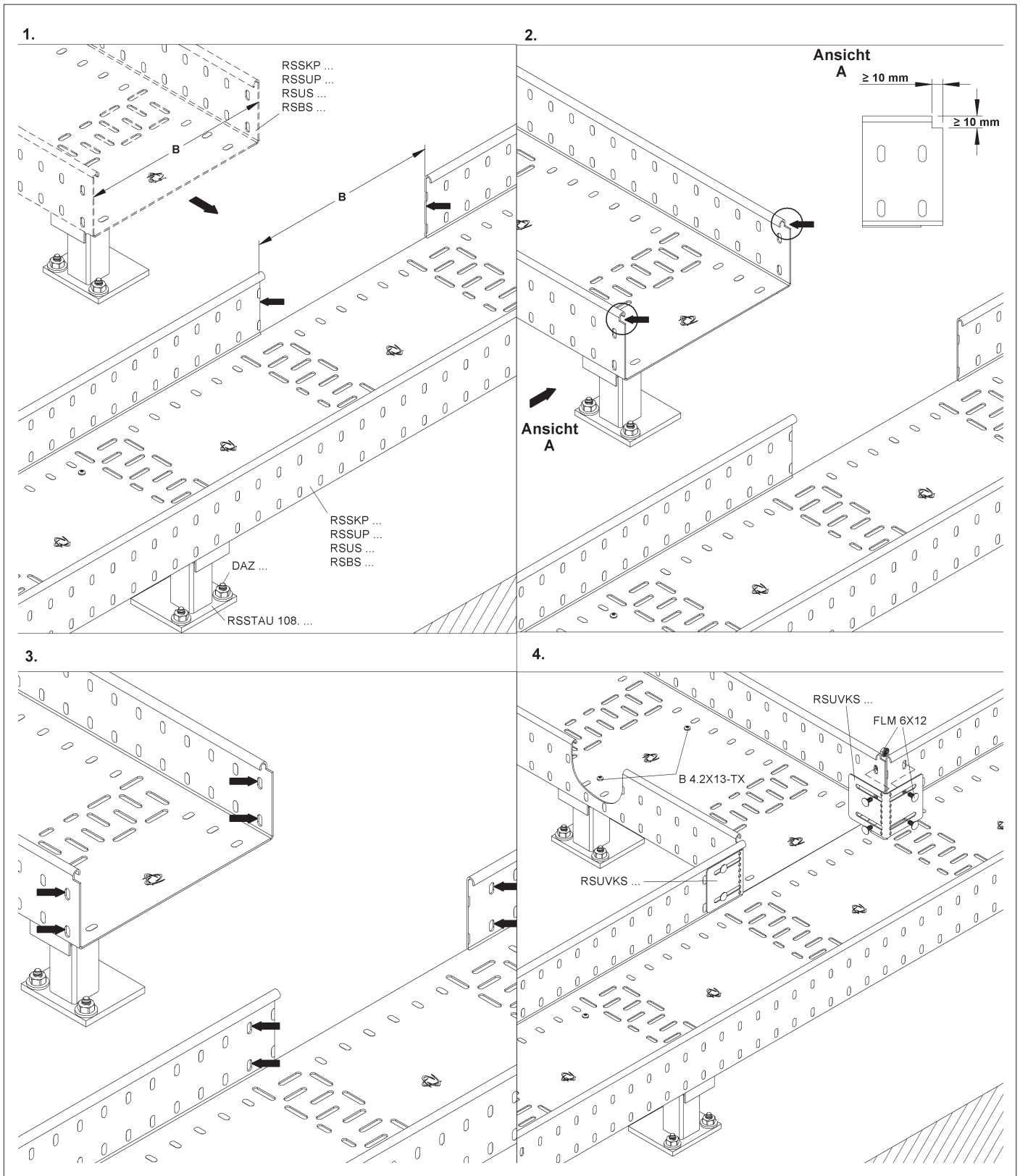

Installation Instructions

RSUVKS...

Forming a tee joint with the RSUVKS... splice plate

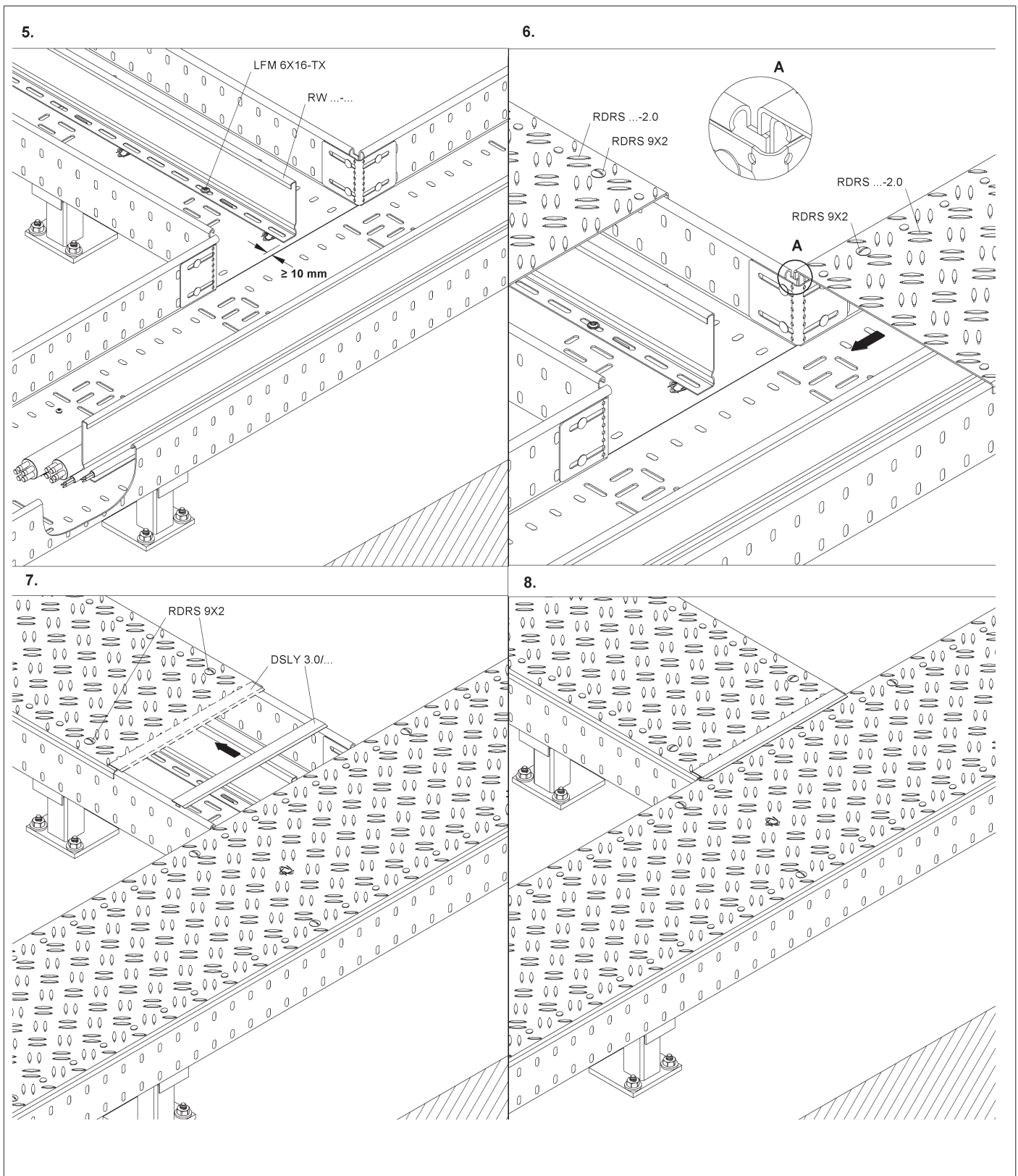

GENERAL INFORMATION

Installation Instructions

Cable trays RSSUP...OV and RSSKP...OV for floor-mount cable tray system

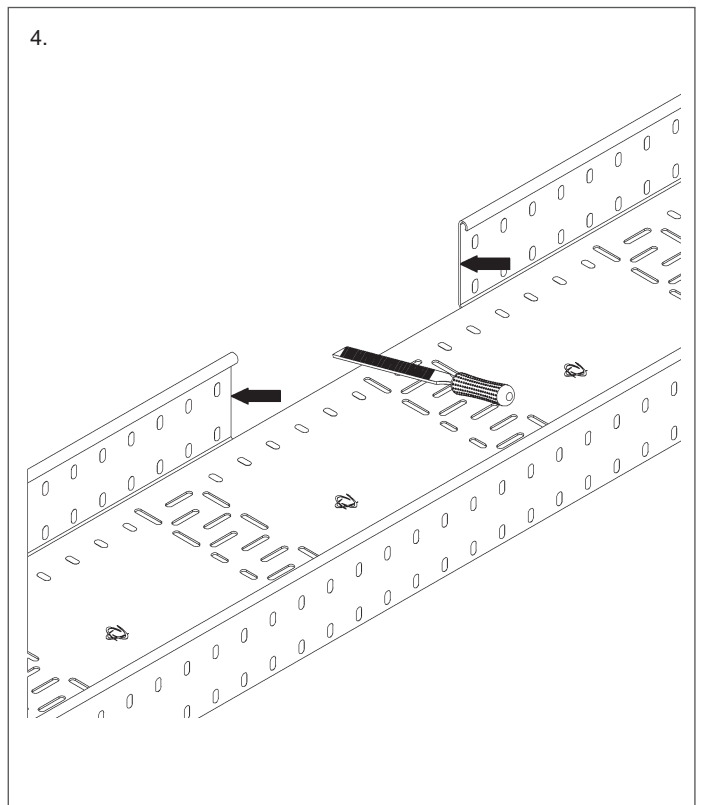
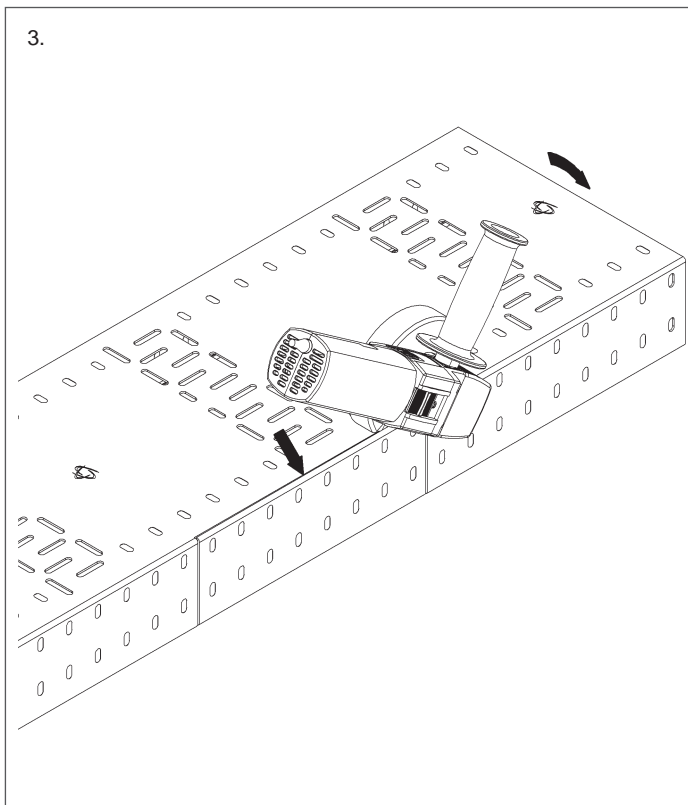
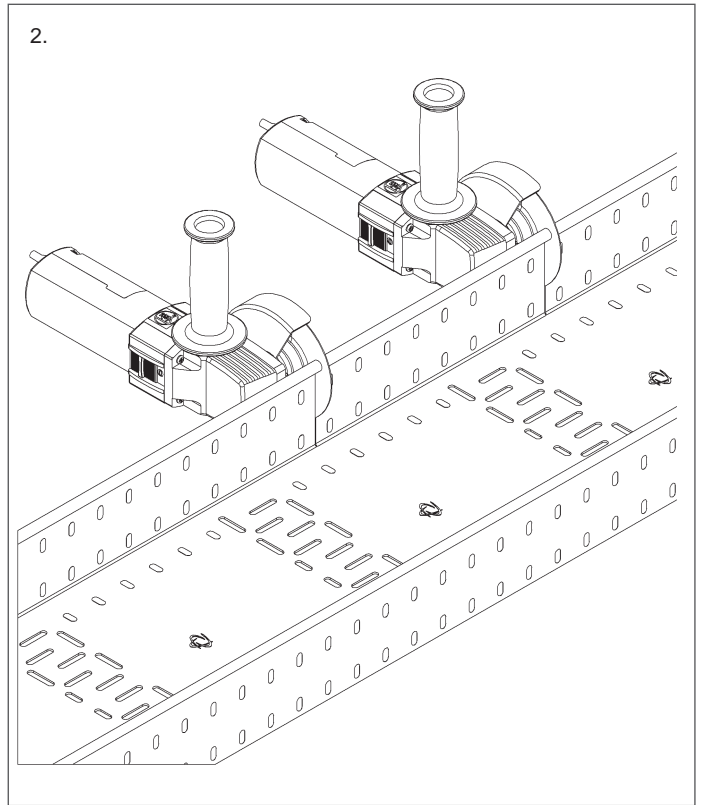
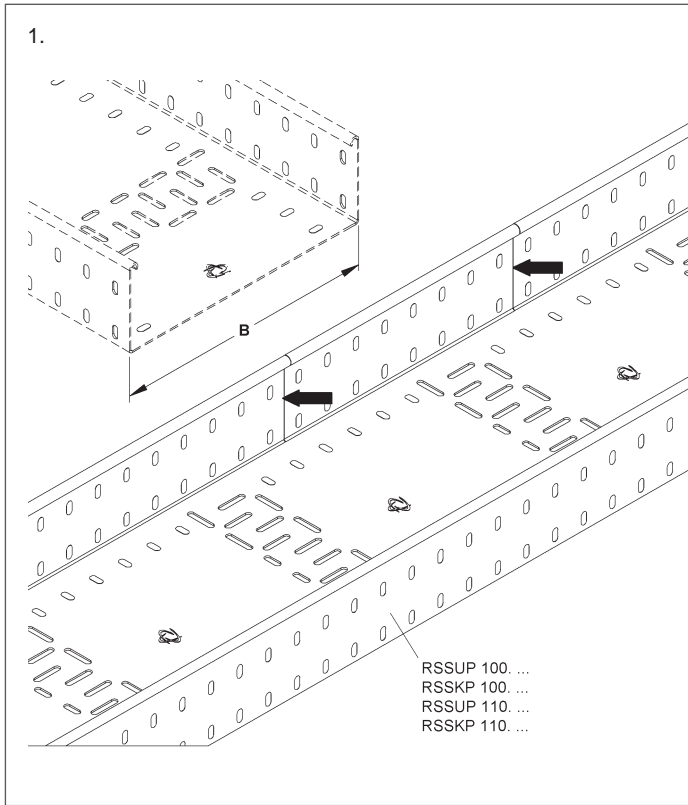

Installation Instructions

Cable trays RSSUP...OV and RSSKP...OV for floor-mount cable tray system

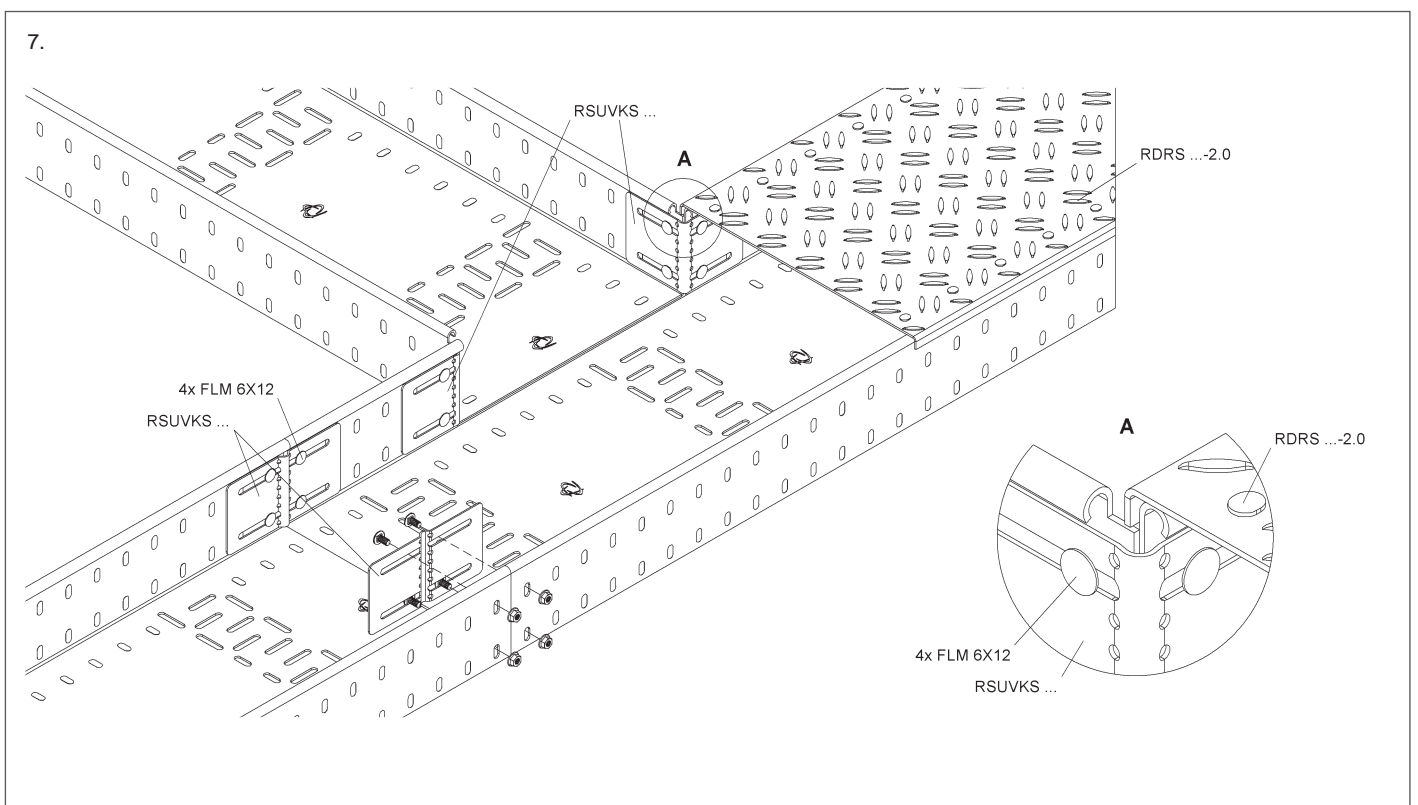
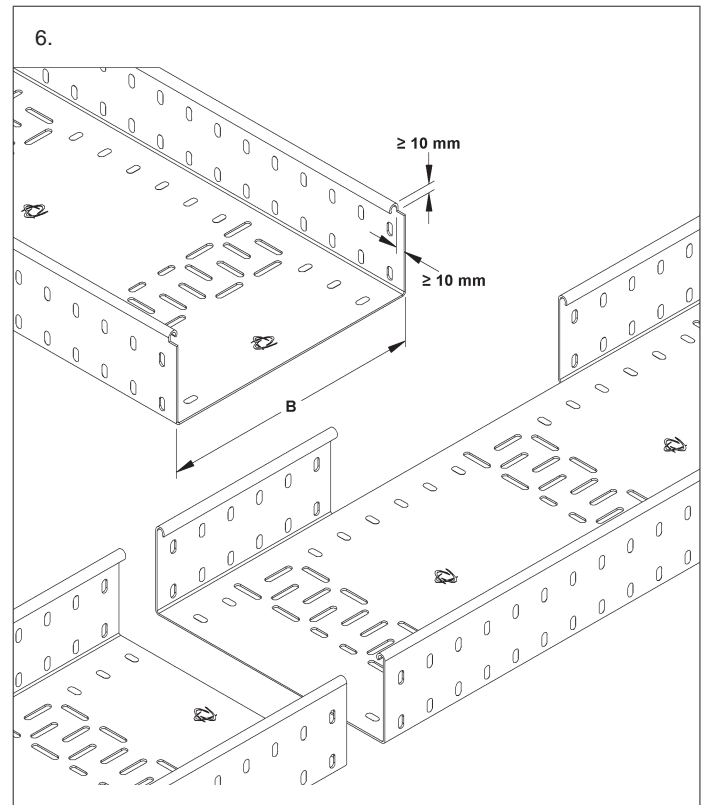
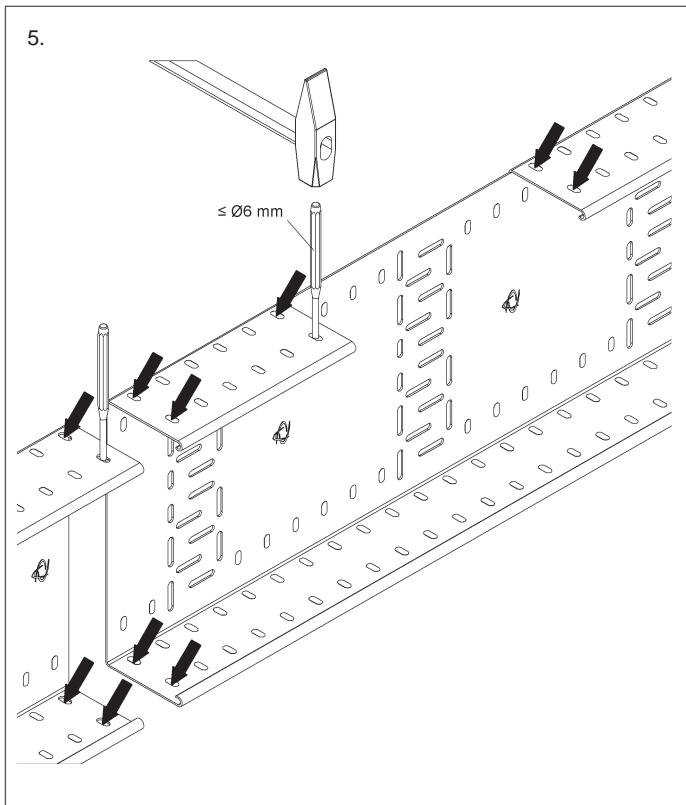

GENERAL INFORMATION

Installation Instructions

TR 86 S

Support TR 86 S in conjunction with C-profile 2986 for cover support without barrier strip assembly.

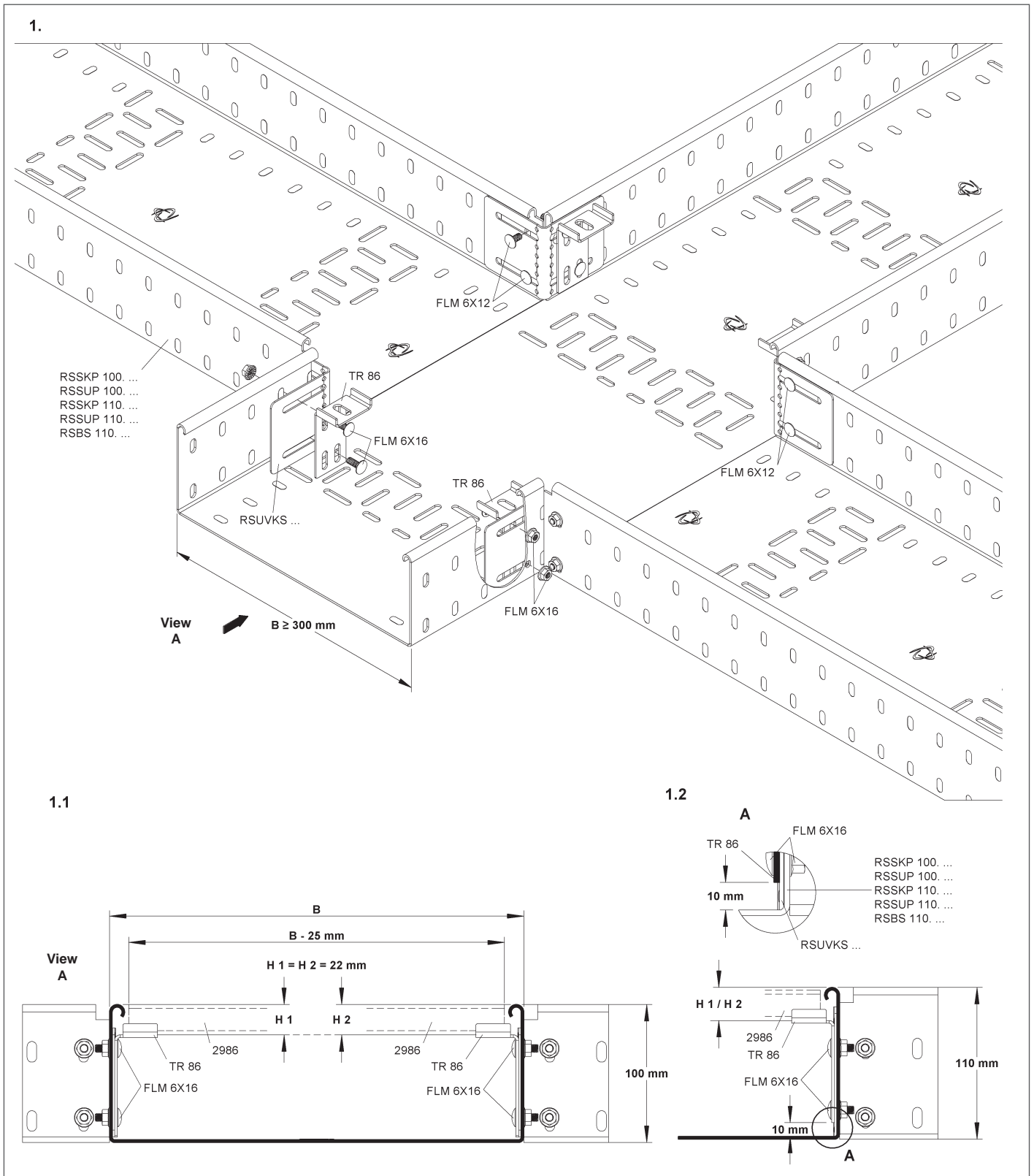

Installation Instructions

TR 86 S

Support TR 86 S in conjunction with C-profile 2986 for cover support without barrier strip assembly.

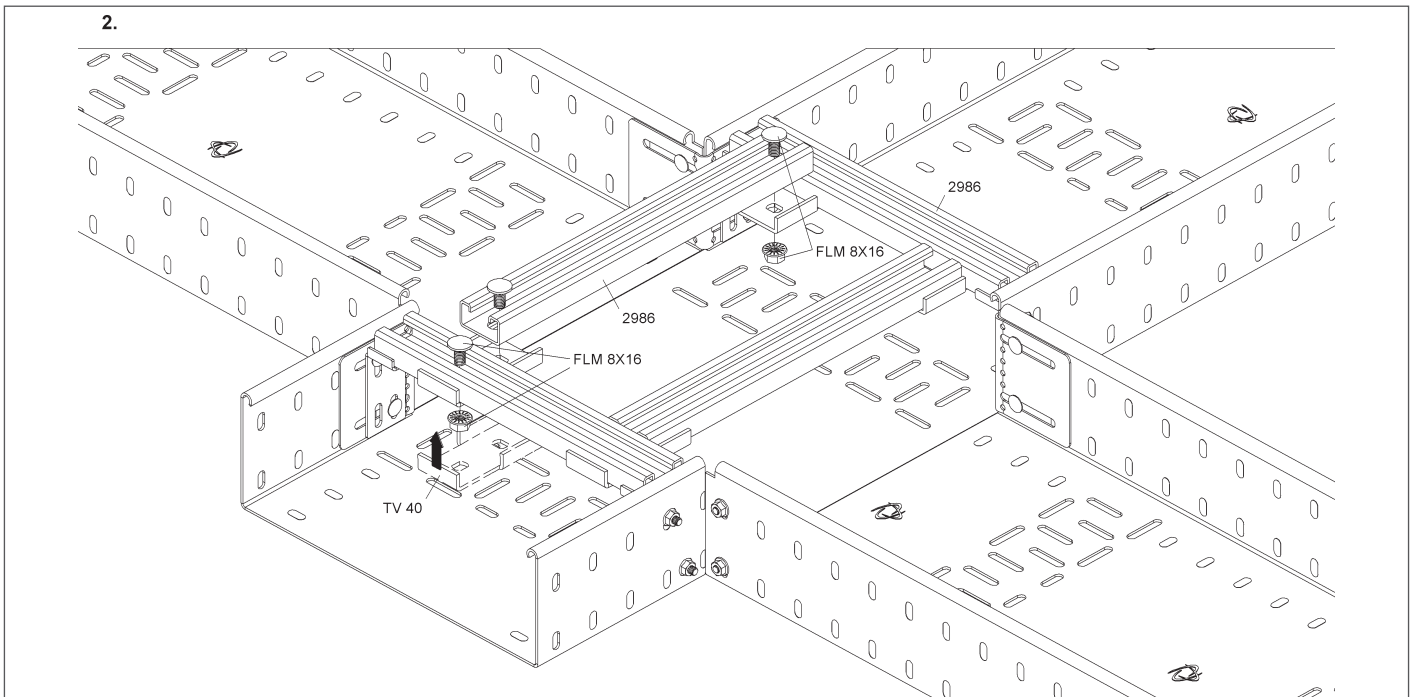

Flexible dismantling of the rails eliminates the need to thread the cables.
The construction is mainly used at crossings, 90° elbows or T-pieces of floor-mount cable trays.

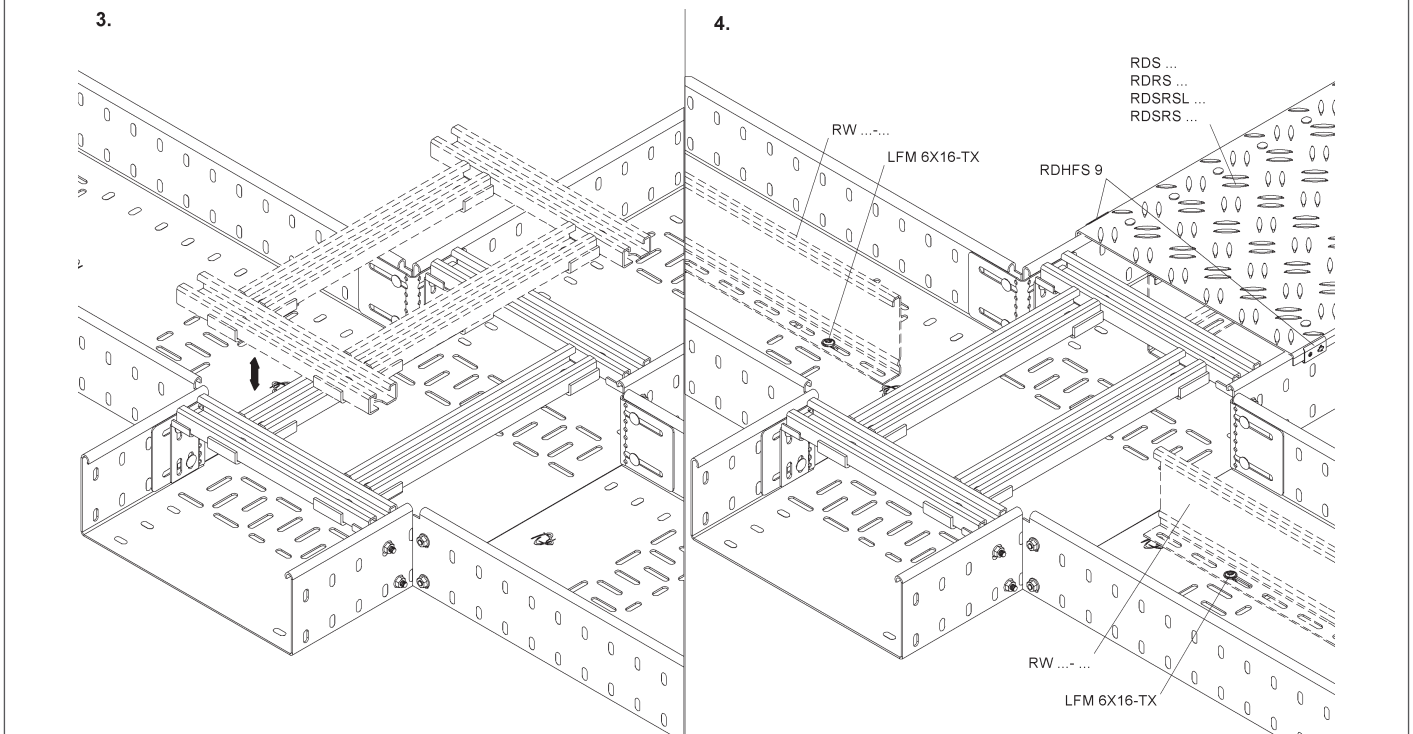

GENERAL INFORMATION

Installation Instructions

RTSQF...

1. Measure the approx. required length (A) of the RTSQF... barrier strip

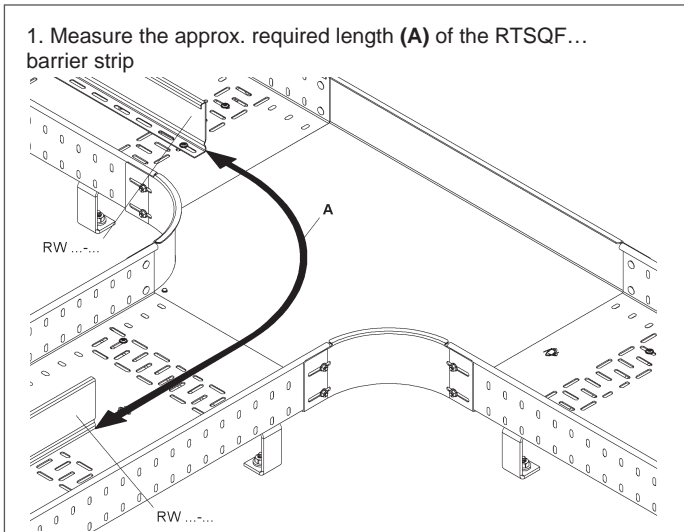

2. The 50 mm segments make it easier to measure and cut the barrier strip (B) to the approximate length required.

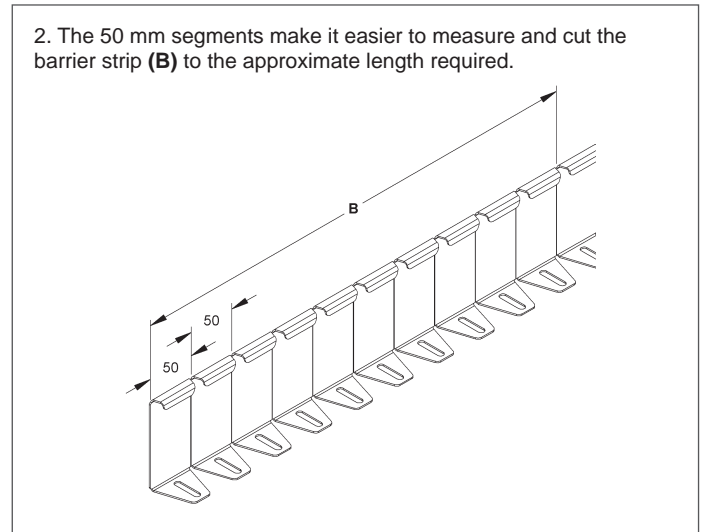

3. The barrier strip can be shortened by 50 mm per segment in each case by bending over the relevant segment(s) multiple times to each side.

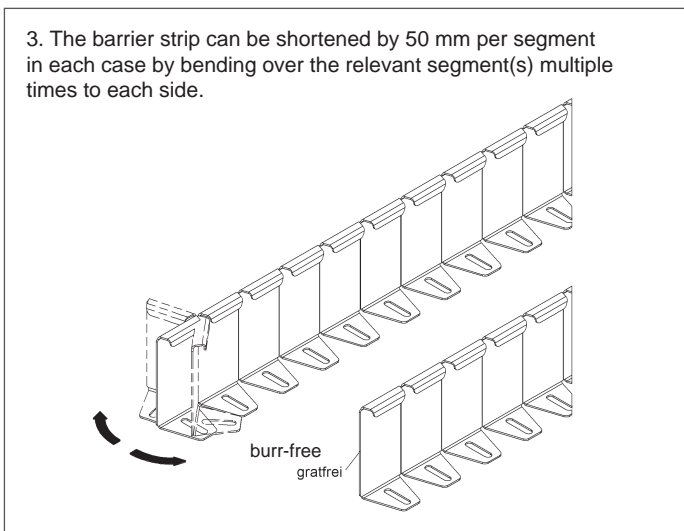

4. Flexible adjustments to the barrier strip can be easily achieved by hand without the need for tools. It is possible to adjust the form of the barrier strip in both directions.

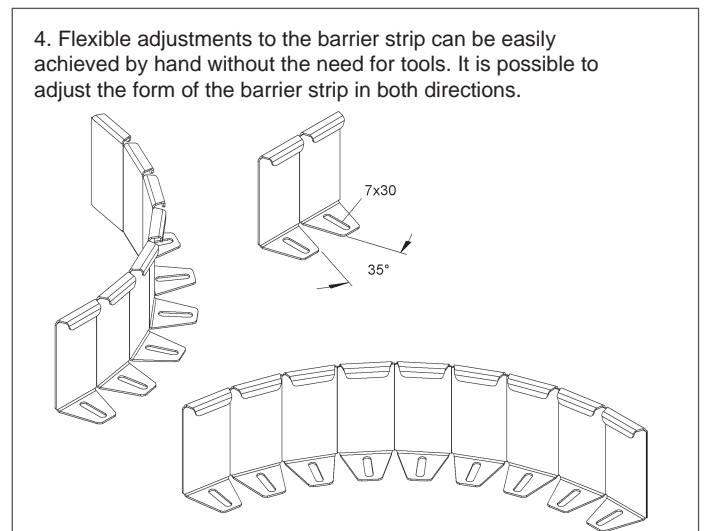

5. Inserting the RTSQF... flexible barrier strip will create a continuous partition in the tray compartment and also provides linked support to the fitted cover in one step.

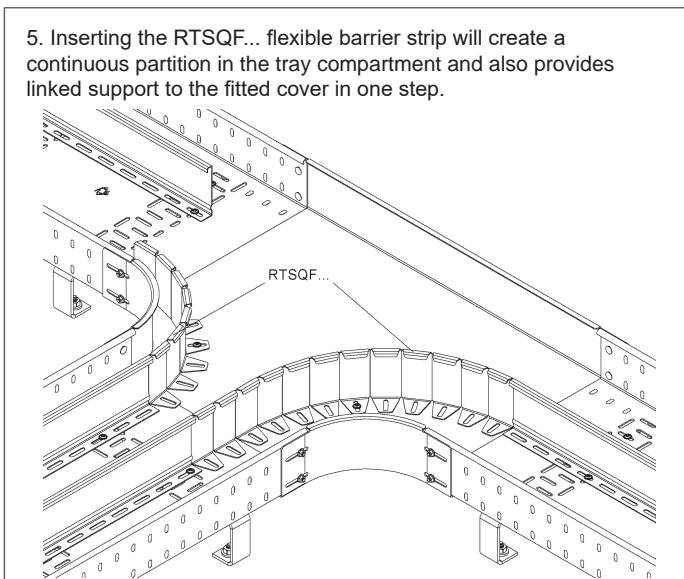

6. If required, individual or multiple segments (C) can be used to provide additional support for the fitted cover.

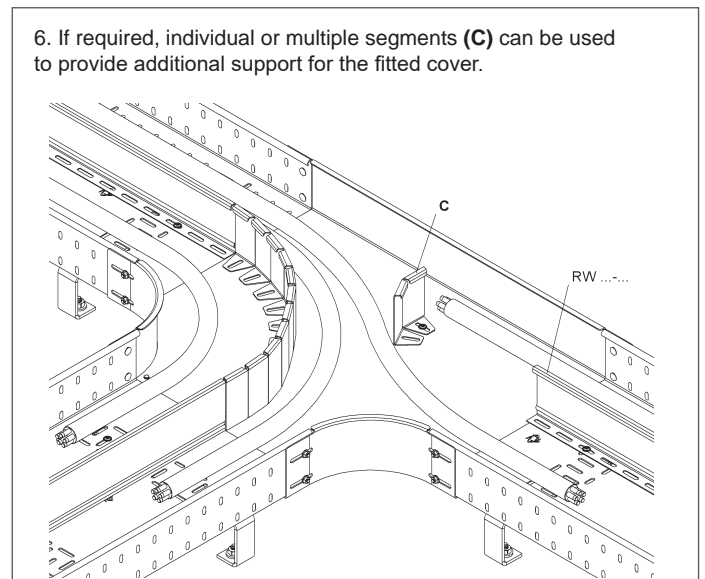

Installation Instructions

RDHFS 9 VZL

How to install/deinstall the cover clamp RDHFS 9 VZL

Install

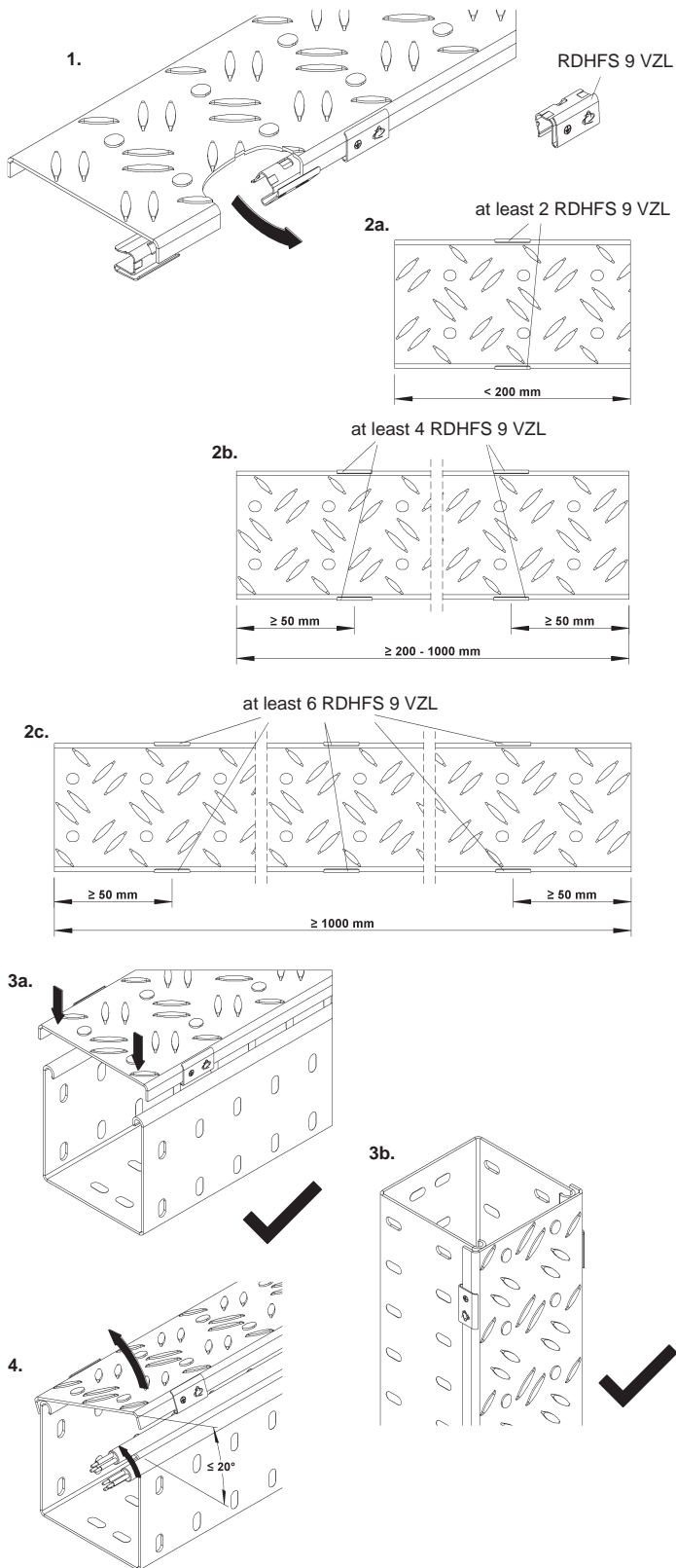

Deinstall

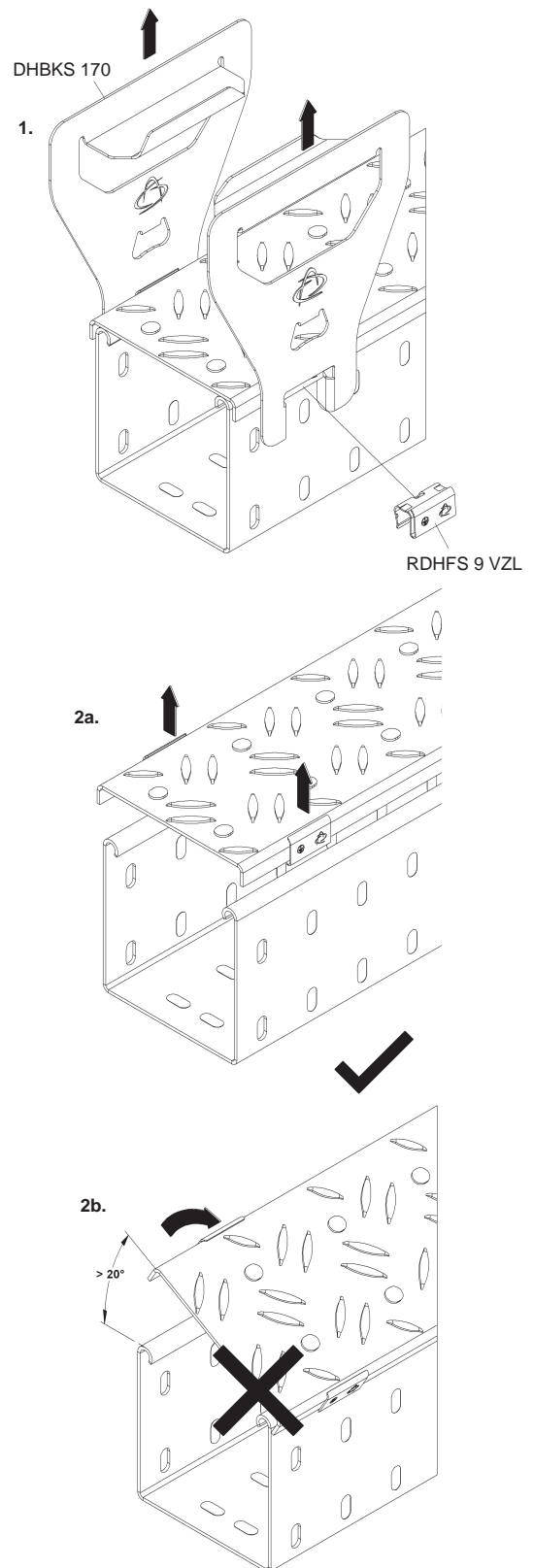

GENERAL INFORMATION

Installation Instructions

RDRS...-2.0

Preparing the RDRS... anti-slip cable tray cover for fitting with the RDRS 9X2 turnbolt lock

1. Cut the cover at a right angle (1) or the corresponding angle for the change of direction (2).

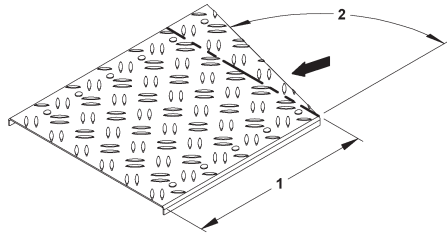

2. Turn the cover over and use a punch to remove the knockouts nearest to the cutting edge (1).

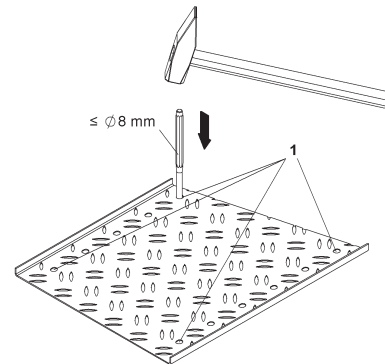

3. Prefit the RDRS 9X2 turnbolt lock as required.

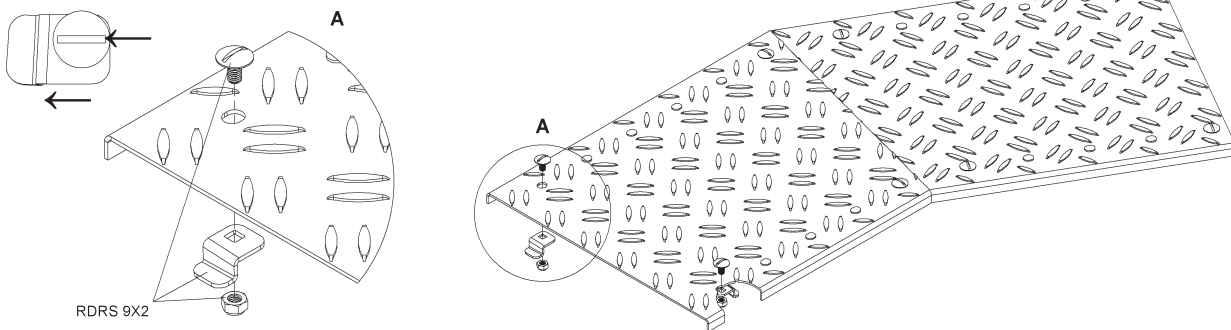

4. Place the RDRS... cable tray cover onto the cable tray and use a screwdriver to screw in the turnbolt locks. The plate on the turnbolt lock grips under the rolled straight edges of the cable tray and thus guarantees a tight connection between the cover and the cable tray.

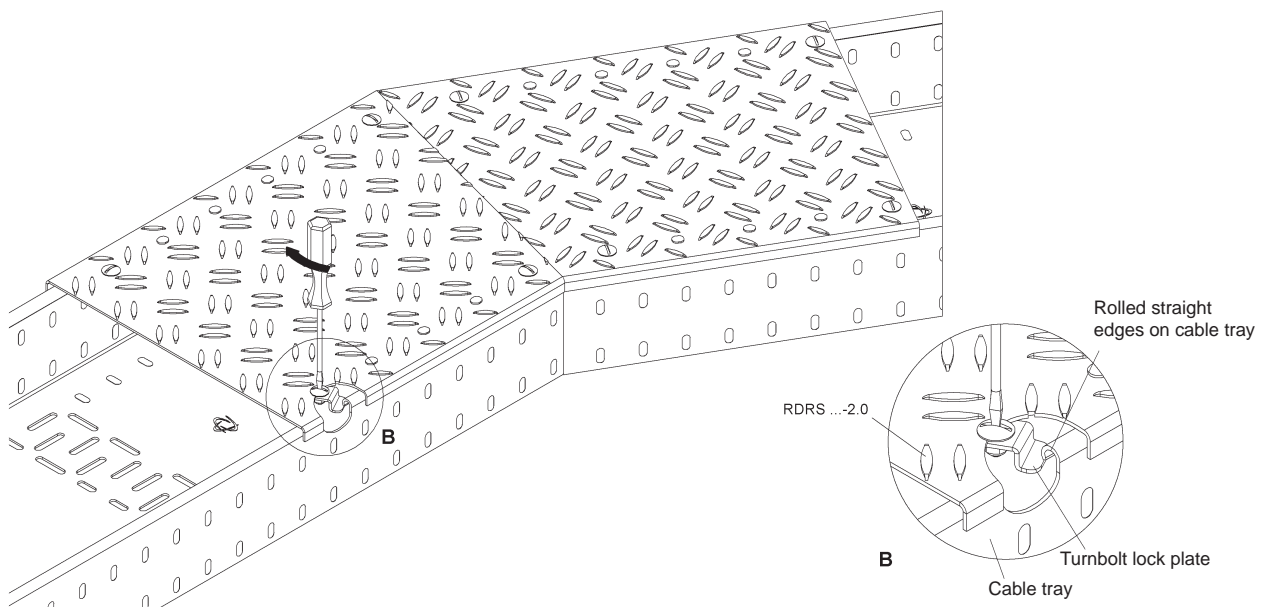

Installation Instructions

How to Install Skirting Panels to RSSTAU 108... Floorstands

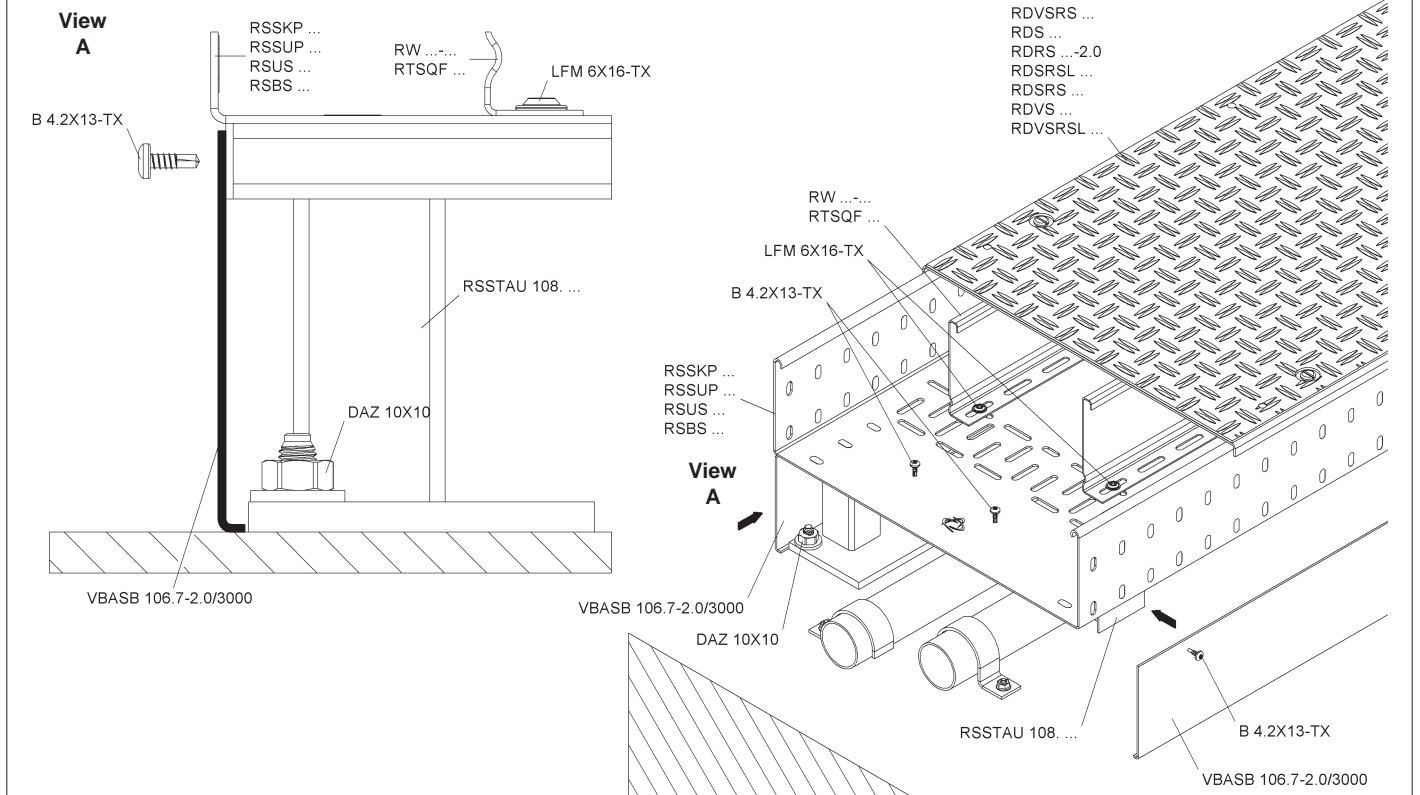

How to Install Skirting Panels to RDB 85... Floorstands

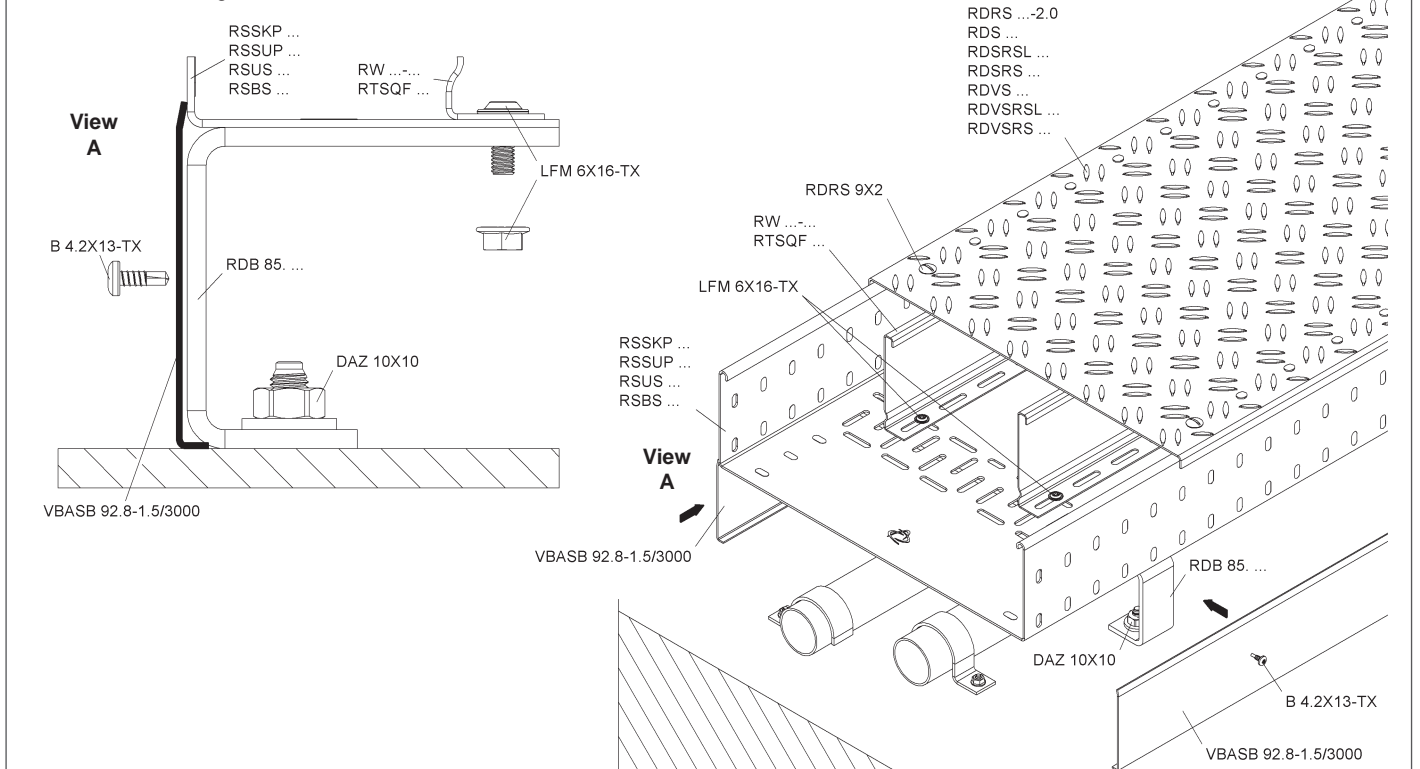

GENERAL INFORMATION

Installation Instructions

RDAH 30...

1.1

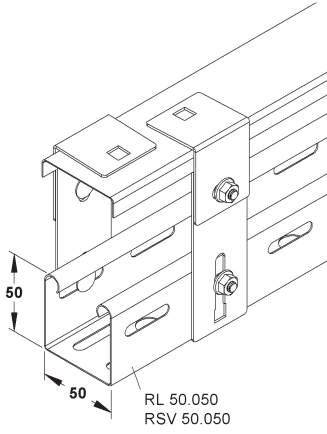

1.2

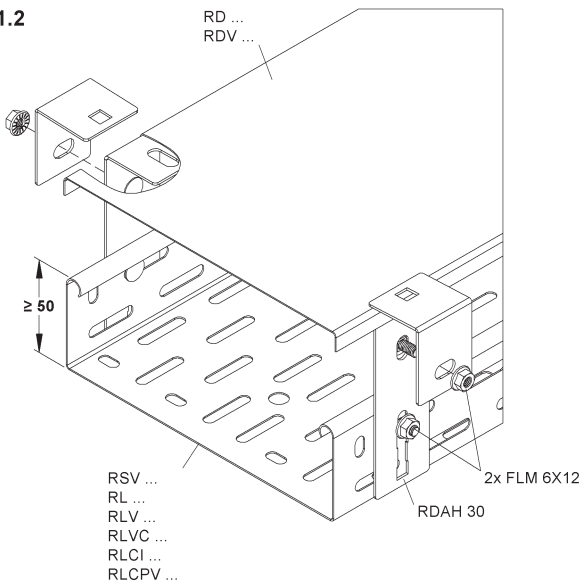

3.

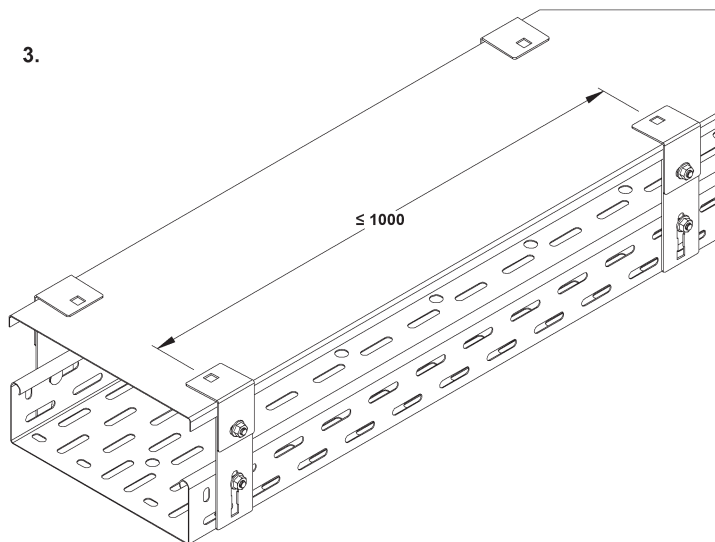

2.1

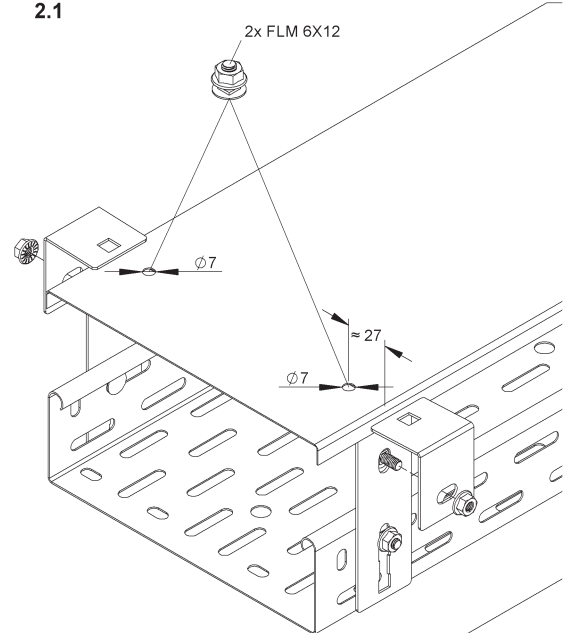

2.2

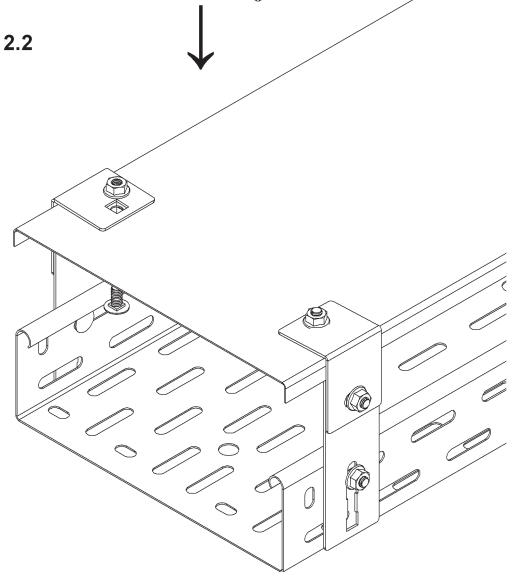

Installation Instructions

RDH 30...

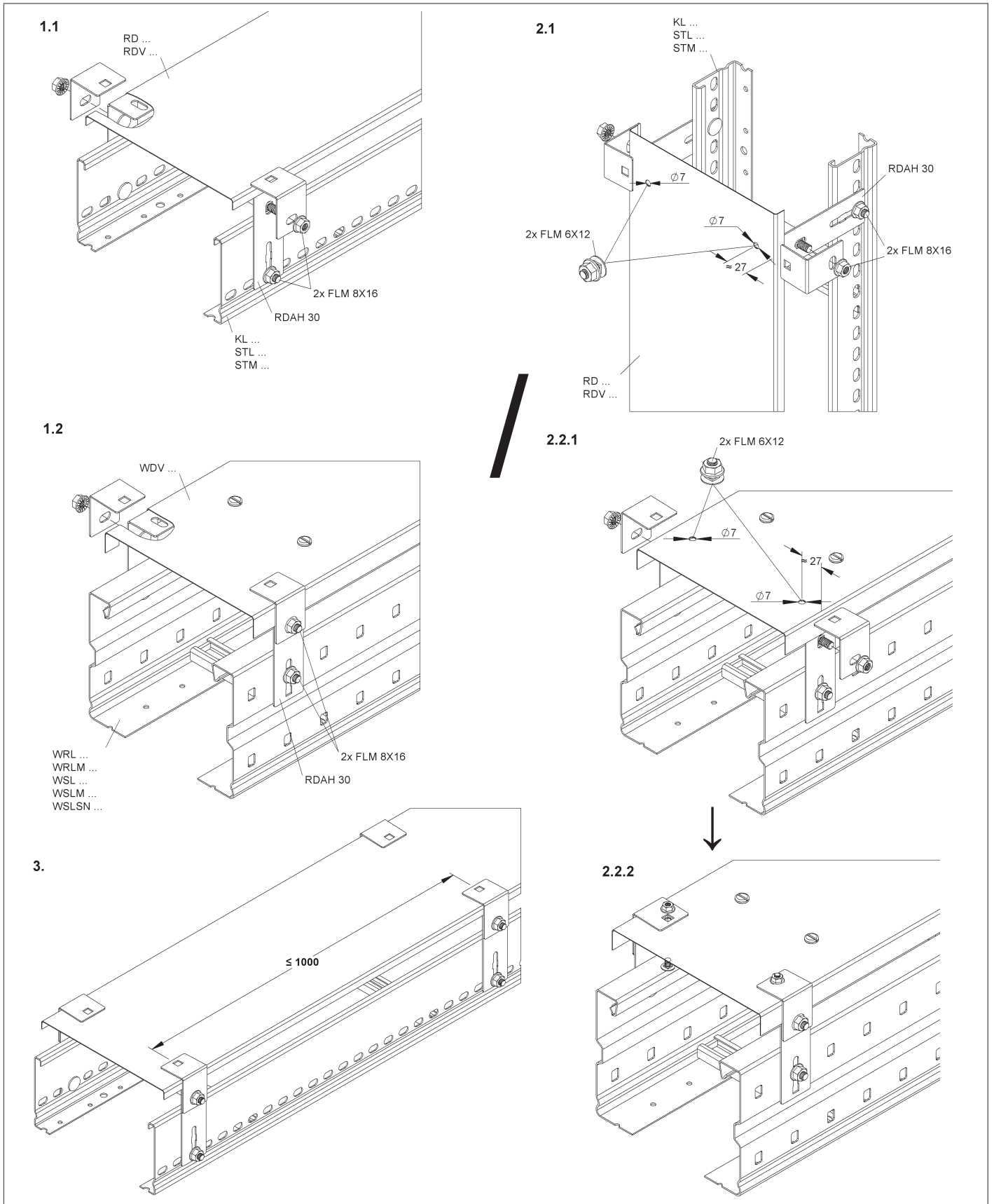

GENERAL INFORMATION

Installation Instructions

WHAS...

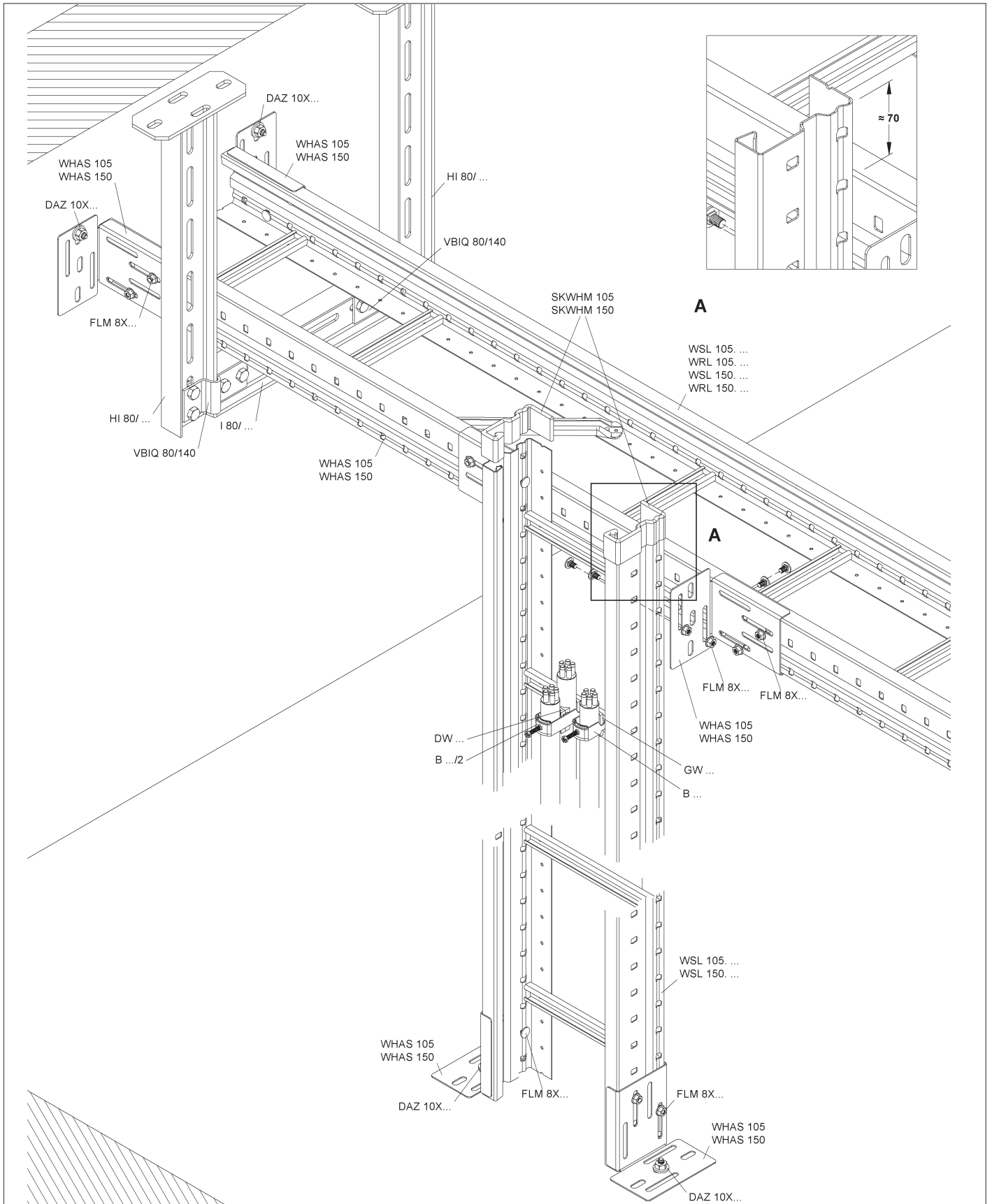

Installation Instructions

Long span ladder with vertical fittings

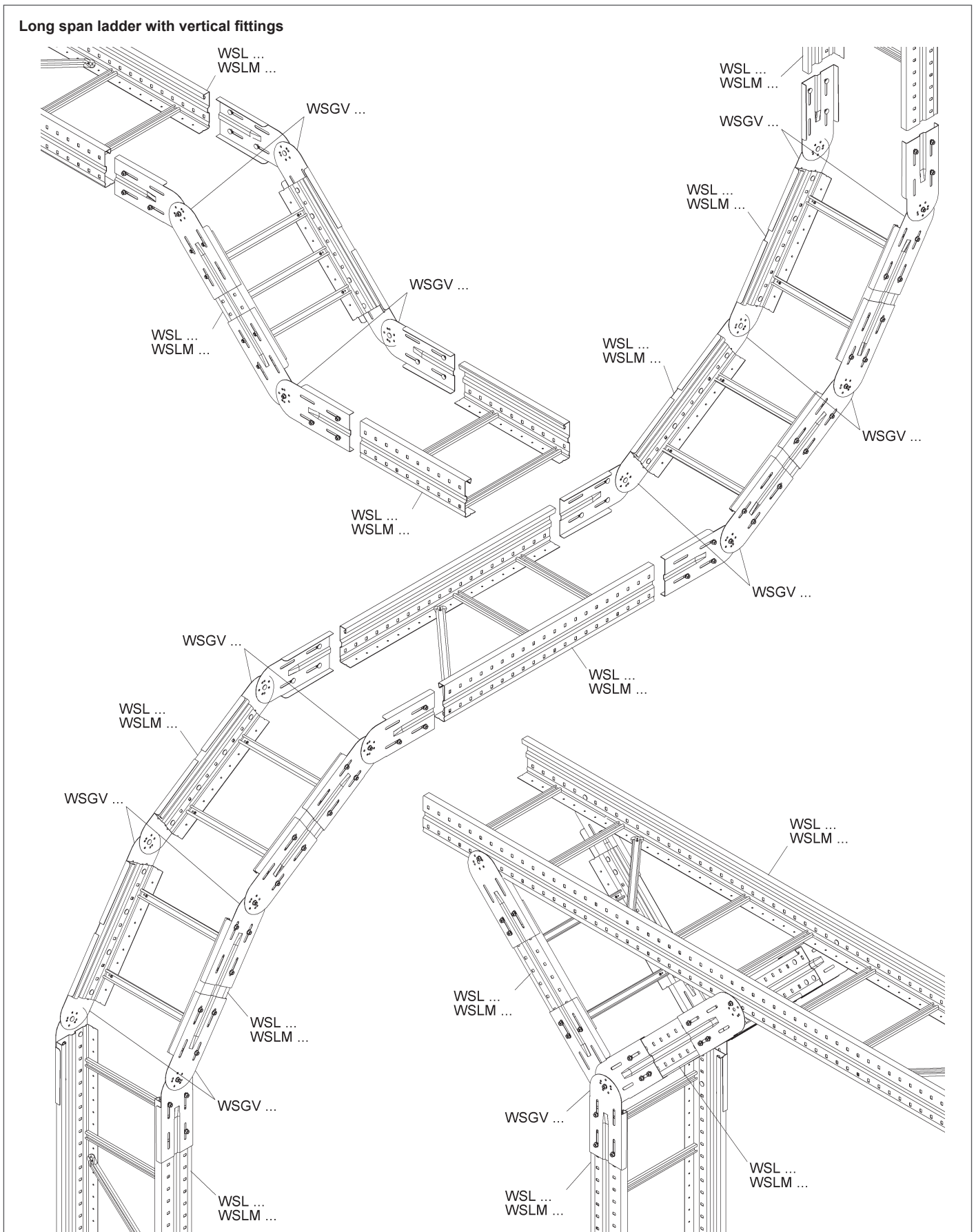

GENERAL INFORMATION

Installation Instructions

WSTAR...

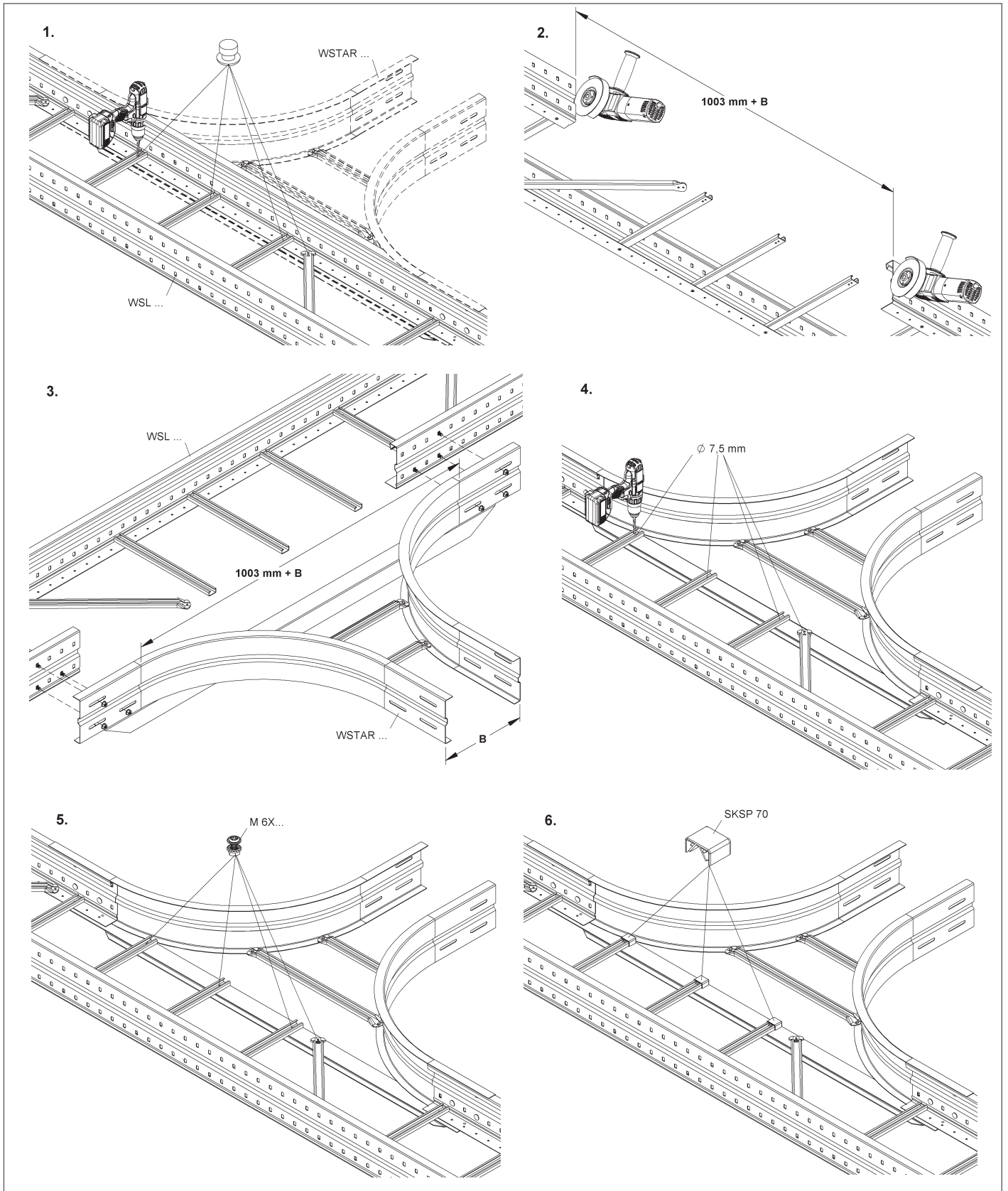

Installation Instructions

WRTAR...

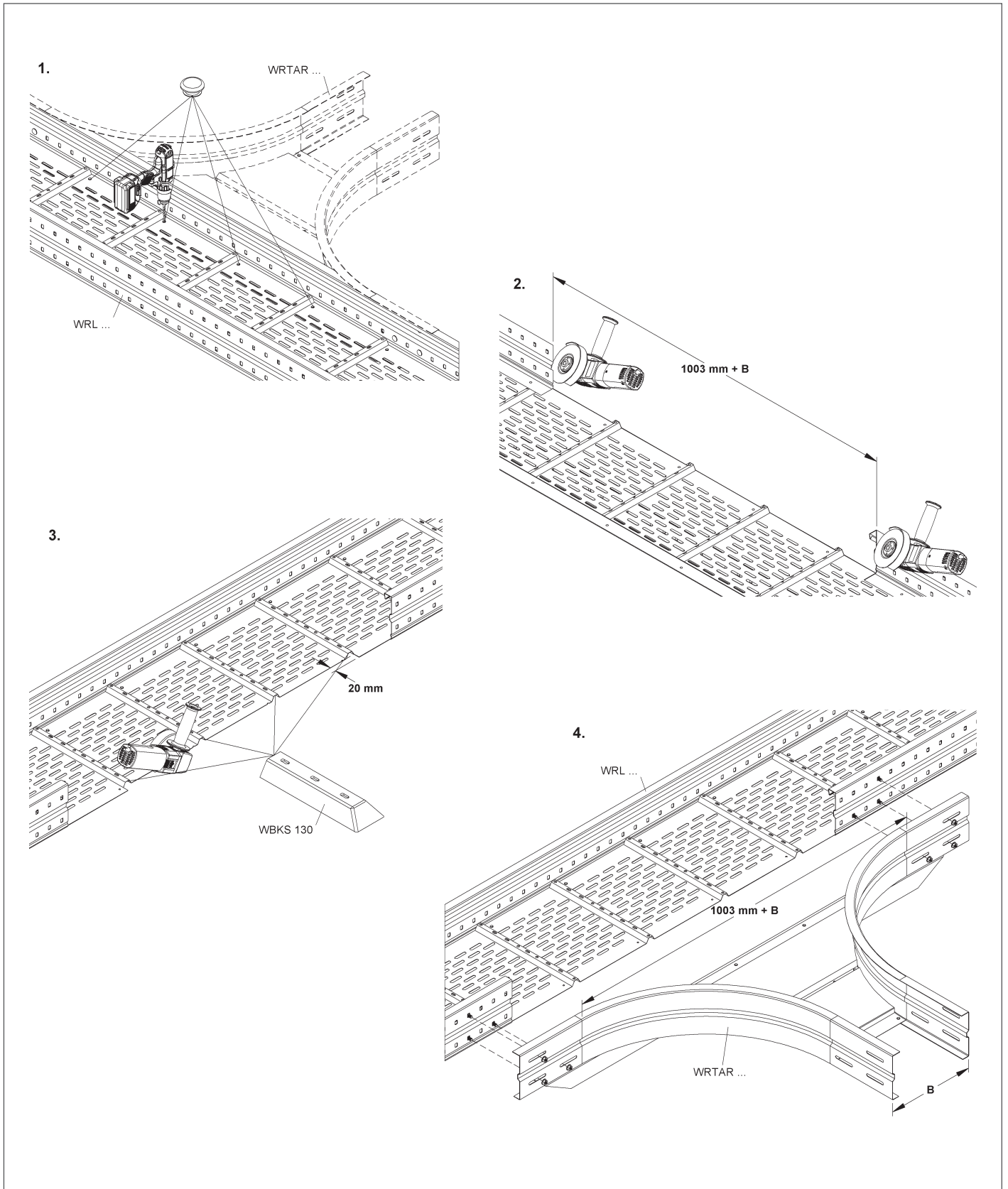

GENERAL INFORMATION

Installation Instructions

WRTAR...

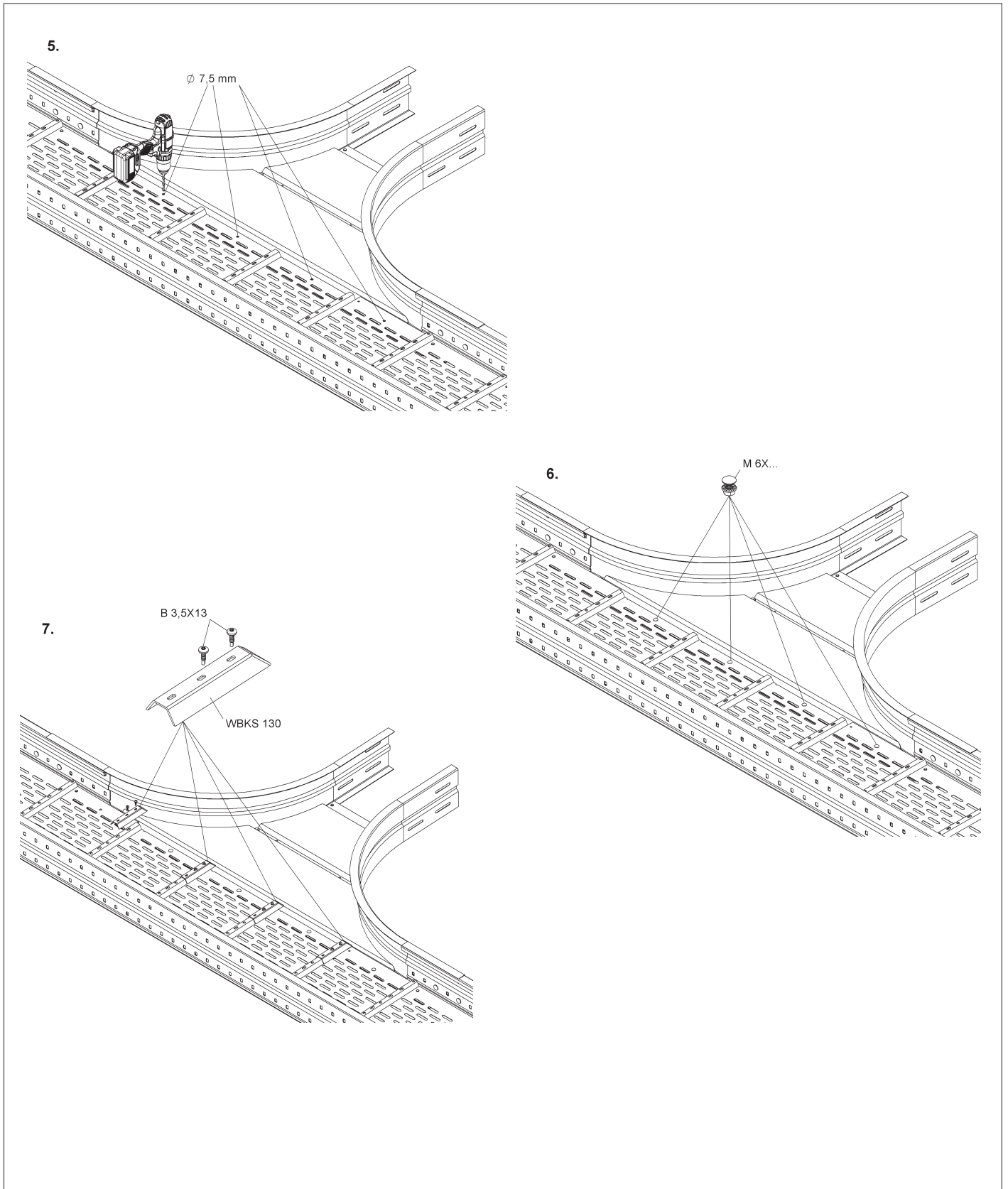

Installation Instructions

How to Build Long Span Reducers

Single Sided Reducer

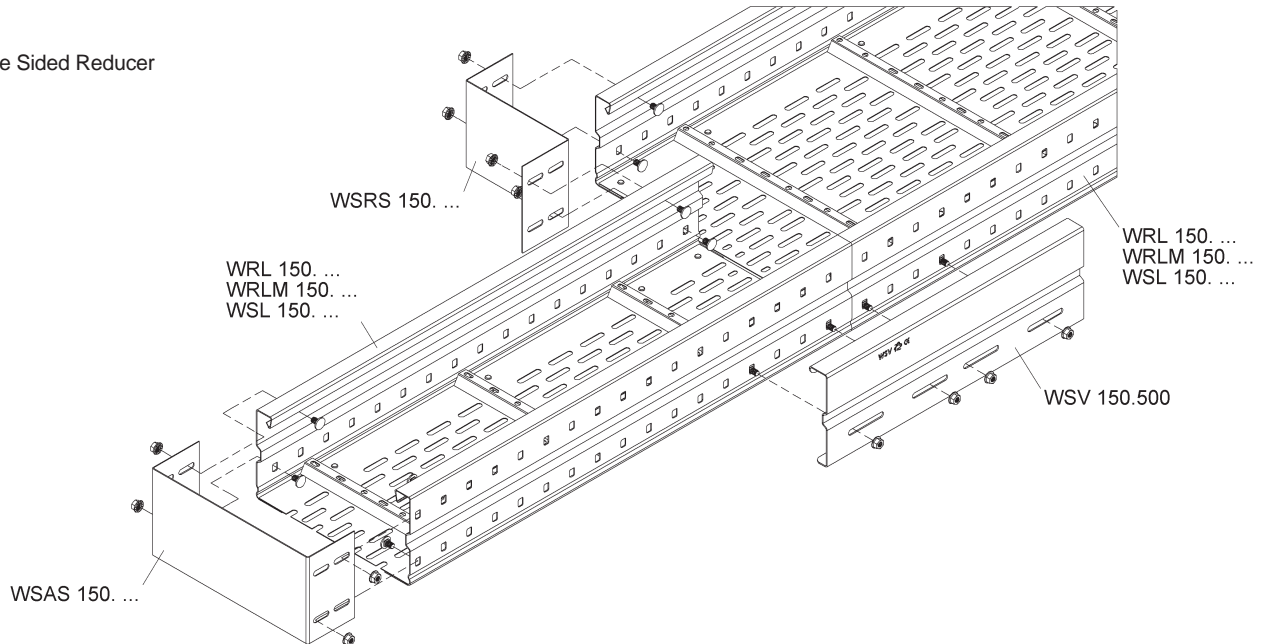

Asymmetrical Reducer

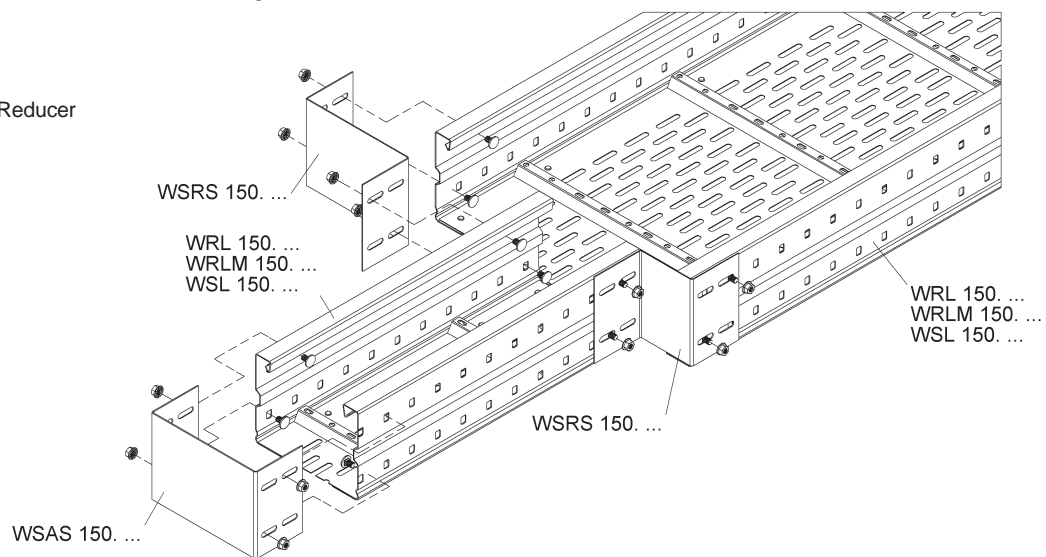

Symmetrical Reducer

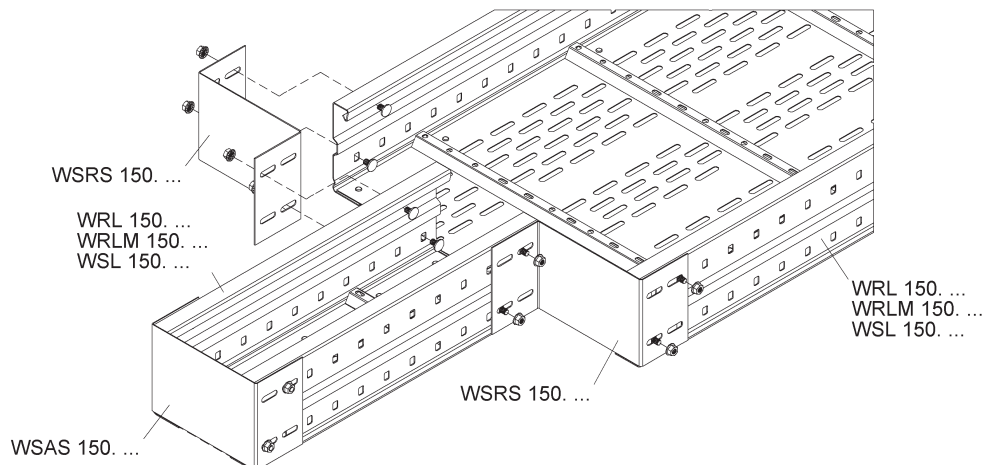

GENERAL INFORMATION

Installation Instructions

Installation of Divider using LZTP... mounting plate

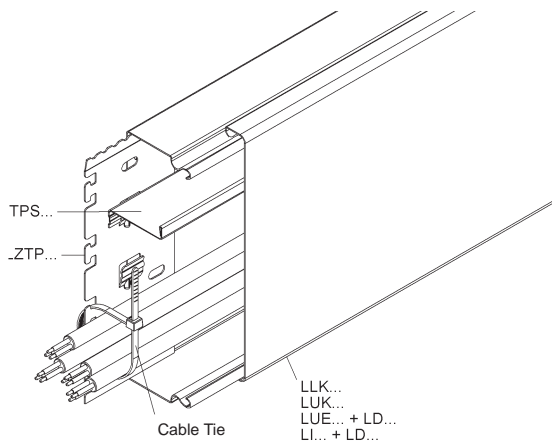

LZTP 100

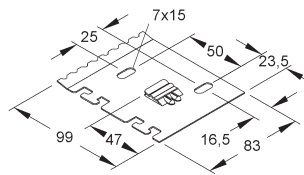

LZTP 150

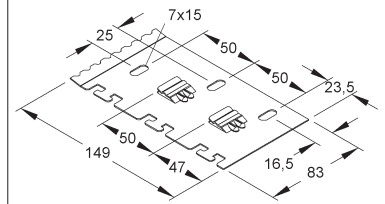

LZTP 200

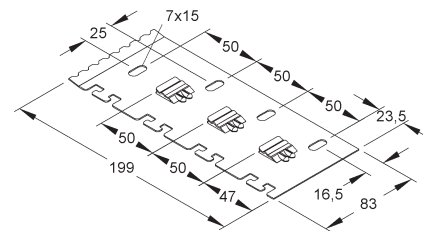

How to install channel cable tray LLK... and LUK... with splice plate LST...

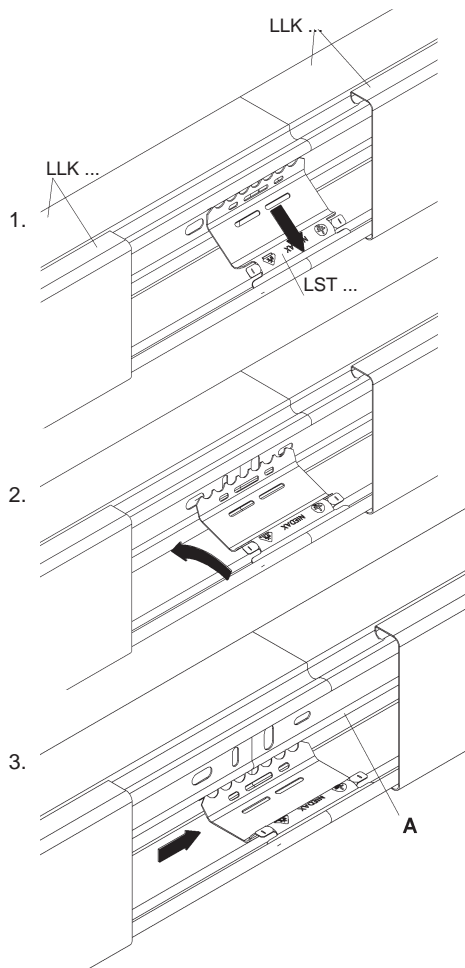

How to install the LST... splice plate

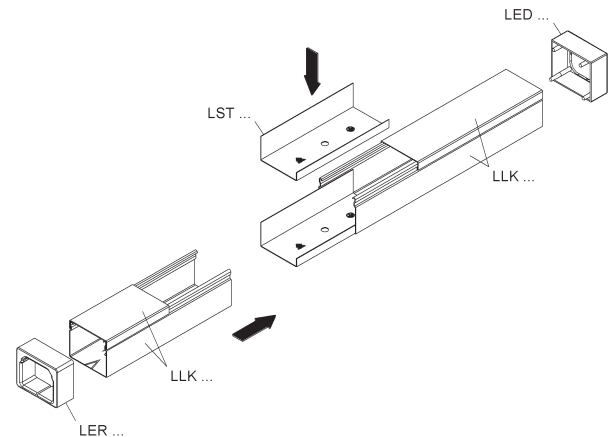

How to install the cable support clamp LHS...

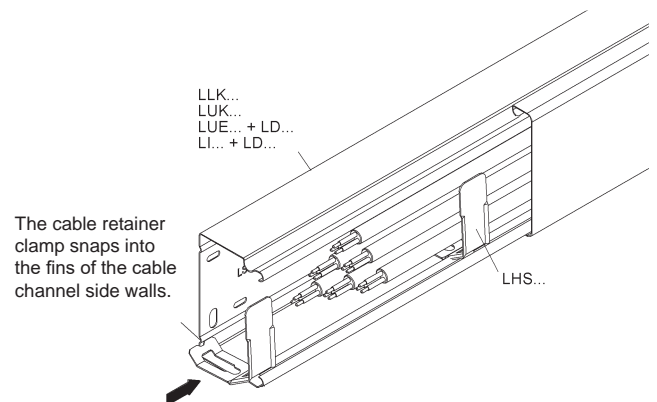

NOTES

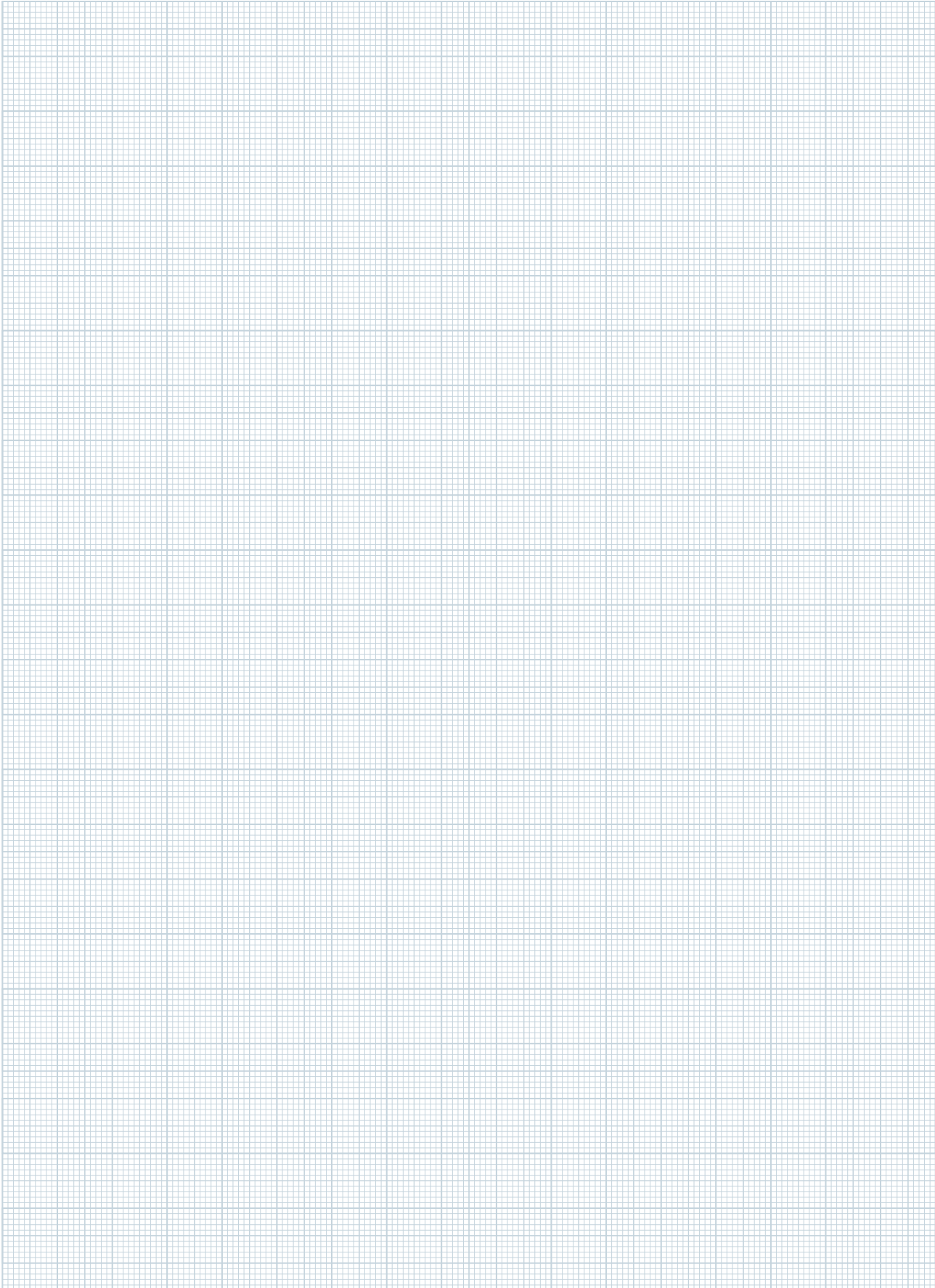

CABLE TRAY SYSTEM

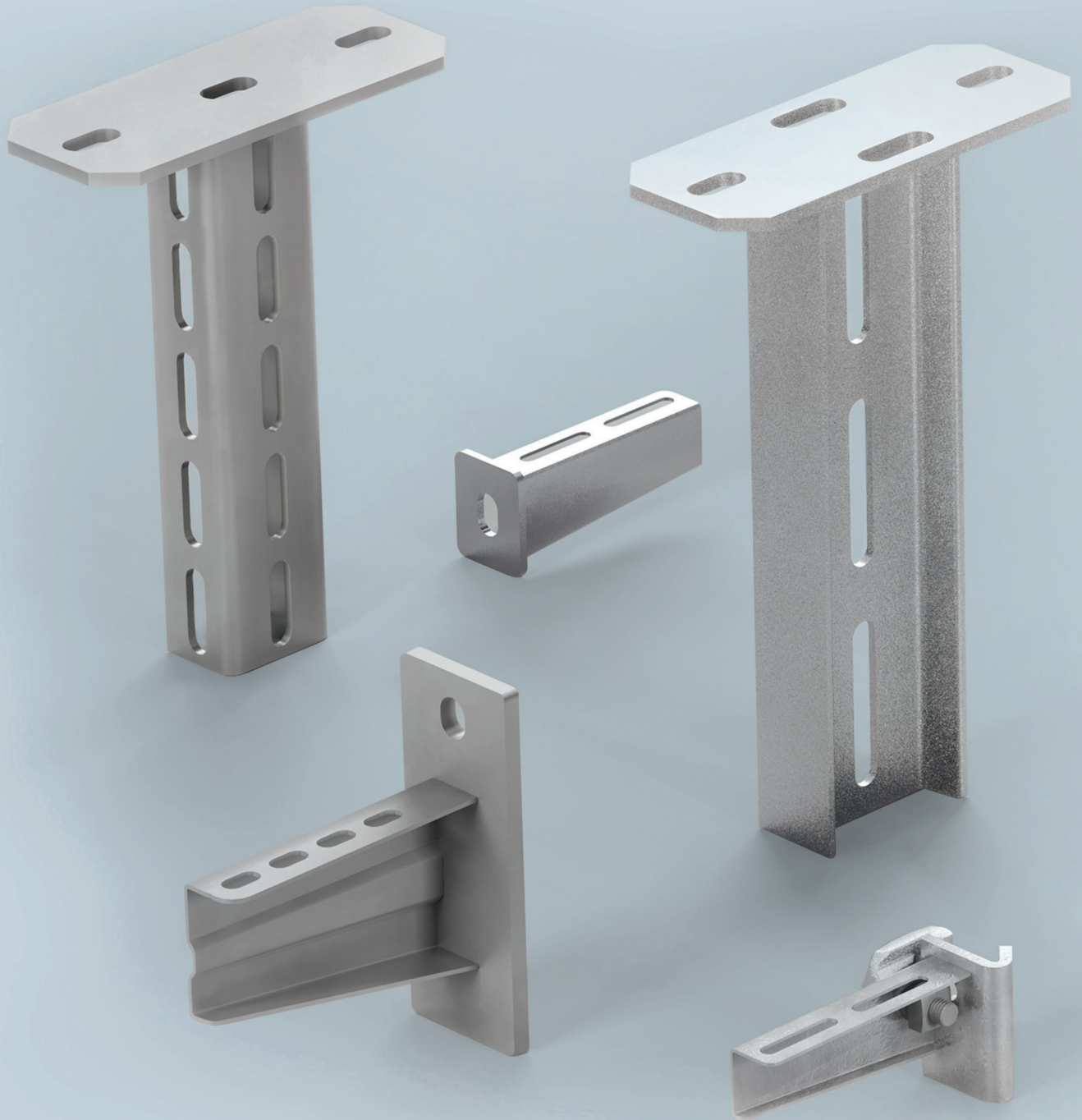

SUPPORT SYSTEM

- Overhead Hangers
- C-Profiles
- Brackets
- Head Plates

Niedax offers a wide variety of support systems for all kinds of applications. Light, medium and heavy duty versions of hangers and brackets for ceiling, floor and wall mount; clamping brackets and headplates for installing to steel structures; C- I- and U-profiles for metal framing; a wide range of accessories like serrated flange nuts, sliding nuts, threaded rod, anchor bolts, ...

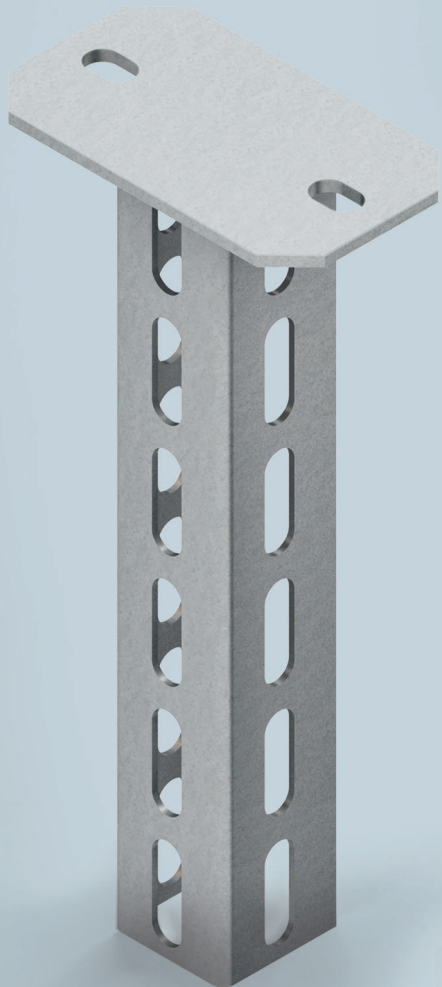

Overview Brackets

SYSTEM	Overhead Hanger and Wall Bracket	KTCL...	Page 94
	Bracket	KTA...	Page 94
	Protective End Cap	KA 100-600	Page 94
	Bracket	KTAS...	Page 94
	Clamping Bracket	KTTSS...	Page 95
	Beam Clamp	HSKS...	Page 95
	Hex Head Bolt with Nut and Washer	SKM...	Page 95
	Offset Flange Bracket	KTU...	Page 96
	Box/Wall Connector	WA...	Page 96



admissible load F at $L/2 = \text{kN}$

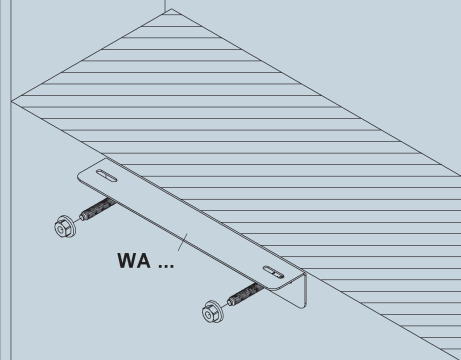
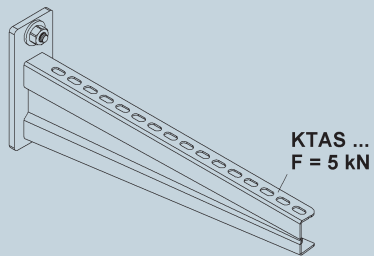
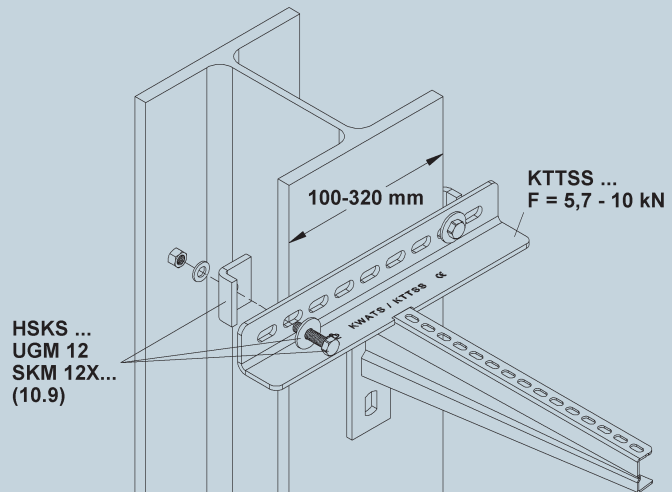
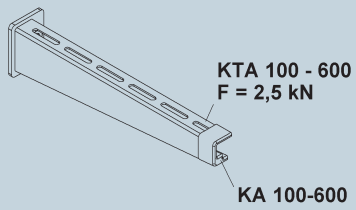
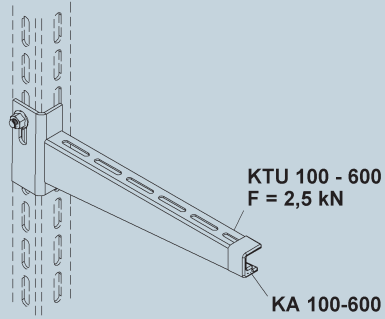
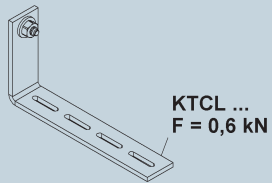

SUPPORT SYSTEM

Overhead Hanger and Wall Bracket

light

	Model no.	Height H	Length L	Thick-ness t	Max. load F at L/2 kN	Acc. incl.	Weight per 100 pcs kg	Pack/Box Qty
		mm Inch	mm Inch					
F	KTCL 100	106 4,2	110 4,3	4	0,6	2 FLM 6X16 F	26,9	20
F	KTCL 200	104 4,1	210 8,3	6	0,6	2 FLM 6X16 F	54,0	20

for mounting on walls or to overhead hangers

The load rating shown is valid only for proper anchorage to the building structure.

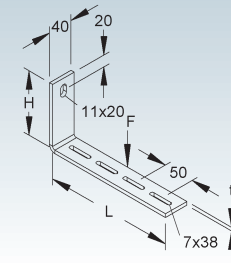

Bracket

standard version

	Model no.	Height H	Width B	Length L	Max. load F at L/2 kN	Acc. incl.	Weight per 100 pcs kg	Pack/Box Qty
		mm Inch	mm Inch	mm Inch				
F	KTA 100	45 1,8	40 1,6	110 4,3	2,5	2 FLM 6X12	15,52	20
F	KTA 150	45 1,8	40 1,6	160 6,3	2,5	2 FLM 6X12	19,05	20
F	KTA 200	55 2,2	40 1,6	210 8,3	2,5	2 FLM 6X12	27,41	20
F	KTA 250	55 2,2	40 1,6	260 10,2	2,5	2 FLM 6X12	32,21	20
F	KTA 300	65 2,6	50 2	310 12,2	2,5	2 FLM 6X12	59,08	20
F	KTA 350	65 2,6	50 2	360 14,2	2,5	2 FLM 6X12	66,35	20
F	KTA 400	75 3	50 2	410 16,1	2,5	2 FLM 6X12	79,08	20
F	KTA 450	75 3	50 2	460 18,1	2,5	2 FLM 6X12	88,02	10
F	KTA 500	90 3,5	50 2	510 20,1	2,5	2 FLM 6X12	111,01	10
F	KTA 550	90 3,5	50 2	560 22	2,5	2 FLM 6X12	133,95	10
F	KTA 600	90 3,5	50 2	610 24	2,5	2 FLM 6X12	127,42	10
E3	KTA 100 E3	45 1,8	40 1,6	110 4,3	2,5	2 FLM 6X12 E3	14,34	20
E3	KTA 200 E3	55 2,2	40 1,6	210 8,3	2,5	2 FLM 6X12 E3	25,24	20
E3	KTA 300 E3	65 2,6	50 2	310 12,2	2,5	2 FLM 6X12 E3	54,22	20
E3	KTA 400 E3	75 3	50 2	410 16,1	2,5	2 FLM 6X12 E3	70,55	20
E3	KTA 500 E3	90 3,5	50 2	510 20,1	2,5	2 FLM 6X12 E3	108,73	10
E3	KTA 600 E3	110 4,3	50 2	610 24	2,5	2 FLM 6X12 E3	130,39	10

for mounting to overhead hangers or for direct wall mount

The load rating shown is valid only for proper anchorage to the building structure. Please consult structural engineering for details and local regulations.



52

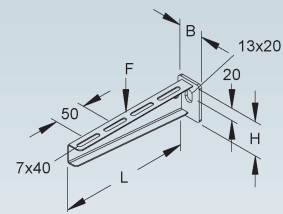

Protective End Cap

	Model no.	Color	Weight per 100 pcs kg	Pack/Box Qty
K10	KA 100-600	yellow	1,4	10

Suitable for: brackets KTA..., KTT... and KTU...



38

39

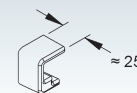

Bracket

heavy-duty

	Model no.	Height H	Length L	Max. load F at L/2 kN	Weight per 100 pcs kg	Pack/Box Qty
		mm Inch	mm Inch			
F	KTAS 100	113 4,4	130 5,1	5	89,95	1
F	KTAS 200	113 4,4	230 9,1	5	108,46	1
F	KTAS 300	113 4,4	330 13	5	130,76	1
F	KTAS 400	113 4,4	430 16,9	5	155,40	1
F	KTAS 500	150 5,9	530 20,9	5	197,69	1
F	KTAS 600	150 5,9	630 24,8	5	227,00	1
F	KTAS 700	150 5,9	730 28,7	5	303,23	1
F	KTAS 800	195 7,7	830 32,7	5	364,38	1
F	KTAS 900	195 7,7	930 36,6	5	409,78	1
F	KTAS 1000	195 7,7	1030 40,6	5	458,11	1
E3	KTAS 200 E3	113 4,4	230 9,1	5	99,23	1
E3	KTAS 300 E3	113 4,4	330 13	5	119,63	1
E3	KTAS 400 E3	113 4,4	430 16,9	5	142,17	1
E3	KTAS 500 E3	150 5,9	530 20,9	5	180,87	1
E3	KTAS 600 E3	150 5,9	630 24,8	5	207,67	1

for mounting to overhead hangers or for direct wall mount

The load rating shown is valid only for proper anchorage to the building structure. Please consult structural engineering for details and local regulations.

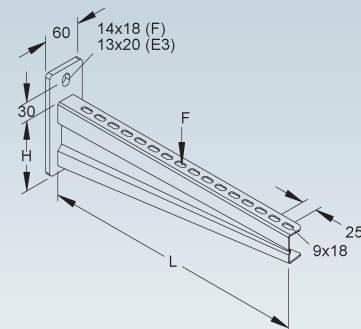

Clamping Bracket

extra heavy-duty version

	Model no.	Height H		Length L		Max. load F at L/2 kN	Admissible load F2 at L/2 kN	Weight per 100 pcs kg	Pack/Box Qty
		mm	Inch	mm	Inch				
F	KTSS 200	156	6,1	230	9,1	10,00	10,0	318,30	1
F	KTSS 300	156	6,1	330	13	10,00	10,0	346,20	1
F	KTSS 400	181	7,1	430	16,9	9,36	10,0	387,39	1
F	KTSS 500	181	7,1	530	20,9	8,89	10,0	421,14	1
F	KTSS 700	206	8,1	730	28,7	7,37	8,0	551,89	1
F	KTSS 800	231	9,1	830	32,7	6,55	7,0	613,28	1
F	KTSS 900	231	9,1	930	36,6	6,28	6,5	667,82	1
F	KTSS 1000	256	10,1	1030	40,6	5,69	6,0	736,21	1

for clamping to beams or for direct wall mount

Please check compliance with recommended fastening torque when installed with HSKS clamps. The load rating shown is valid only when using HSKS... beam clamps with 10.9 grade M12 bolts. Danger of downsiding! Please make sure that there is no paint or protective coating in between the bracket and the I-beam. Please do not remove without permission.

Hardware has to be ordered separately: 2x HSKS..., 2x SKM 12X... (10.9) and 2x UGM 12

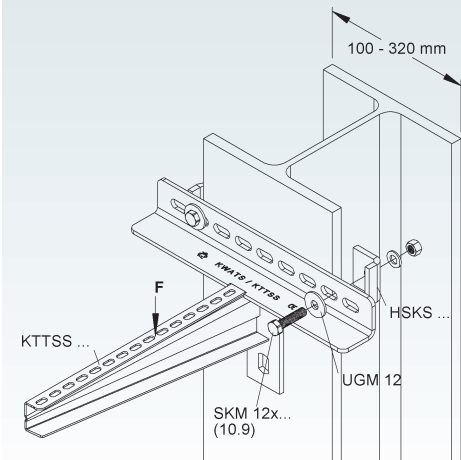
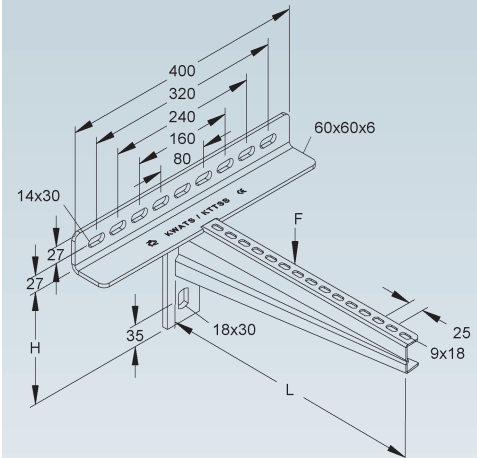

Beam Clamp

heavy-duty version

	Model no.	Height H		Flange thickness t mm	Weight per 100 pcs kg	Pack/Box Qty
		mm	Inch			
F	HSKS 10	10	0,4	5 - 9	22,17	25
F	HSKS 15	15	0,6	10 - 14	24,24	25
F	HSKS 20	20	0,8	15 - 19	26,32	25
F	HSKS 25	25	1	20 - 24	28,39	25
F	HSKS 30	30	1,2	25 - 29	30,46	25
F	HSKS 35	35	1,4	30 - 34	32,53	25
F	HSKS 40	40	1,6	35 - 39	34,61	25

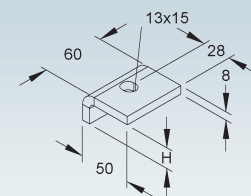

Hex Head Bolt with Nut and Washer

	Model no.	Thread M	Length L		Strength class bolt / nut	Weight per 100 pcs kg	Pack/Box Qty
			mm	Inch			
F	SKM 12X50 F	12	50	2	10.9 / 10	8,27	20
F	SKM 12X70 F	12	70	2,8	10.9 / 10	9,85	20

Please maintain proper tightening torque of bolts/nuts especially for all vertical clamping connections.



49

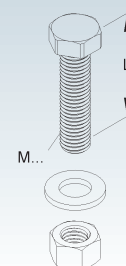

SUPPORT SYSTEM

Offset Flange Bracket

heavy-duty

	Model no.	Height H		Length L		Max. load F at L/2 kN	Acc. incl.	Weight per 100 pcs kg	Pack/Box Qty
		mm	Inch	mm	Inch				
F	KTU 100	50	2	110	4,3	2,5	2 FLM 6X12, 1 FLM 10X25 F	32,26	20
F	KTU 150	50	2	160	6,3	2,5	2 FLM 6X12, 1 FLM 10X25 F	35,79	20
F	KTU 200	60	2,4	210	8,3	2,5	2 FLM 6X12, 1 FLM 10X25 F	45,20	20
F	KTU 250	60	2,4	260	10,2	2,5	2 FLM 6X12, 1 FLM 10X25 F	50,00	20
F	KTU 300	75	3	310	12,2	2,5	2 FLM 6X12, 1 FLM 10X25 F	73,91	20
F	KTU 400	75	3	410	16,1	2,5	2 FLM 6X12, 1 FLM 10X25 F	88,51	20
F	KTU 500	90	3,5	510	20,1	2,5	2 FLM 6X12, 1 FLM 10X25 F	124,52	10
F	KTU 600	90	3,5	610	24	2,5	2 FLM 6X12, 1 FLM 10X25 F	140,93	10

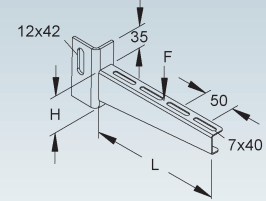

Box/Wall Connector

	Model no.	Width B		Acc. incl.	Weight per 100 pcs kg	Pack/Box Qty
		mm	Inch			
S	WA 100	110	4,3	2 FLM 6X12	17,80	10
S	WA 150	160	6,3	2 FLM 6X12	25,71	10
S	WA 200	210	8,3	2 FLM 6X12	33,62	10
S	WA 250	260	10,2	2 FLM 6X12	41,52	10
S	WA 300	310	12,2	2 FLM 6X12	49,43	10
S	WA 400	410	16,1	2 FLM 6X12	64,61	10
S	WA 500	510	20,1	2 FLM 6X12	80,42	10
S	WA 600	610	24	2 FLM 6X12	96,24	10

for attaching cable tray to a box or a wall

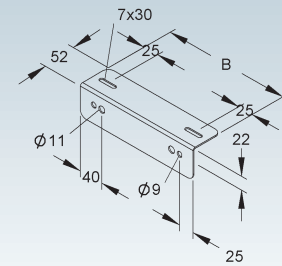

NOTES

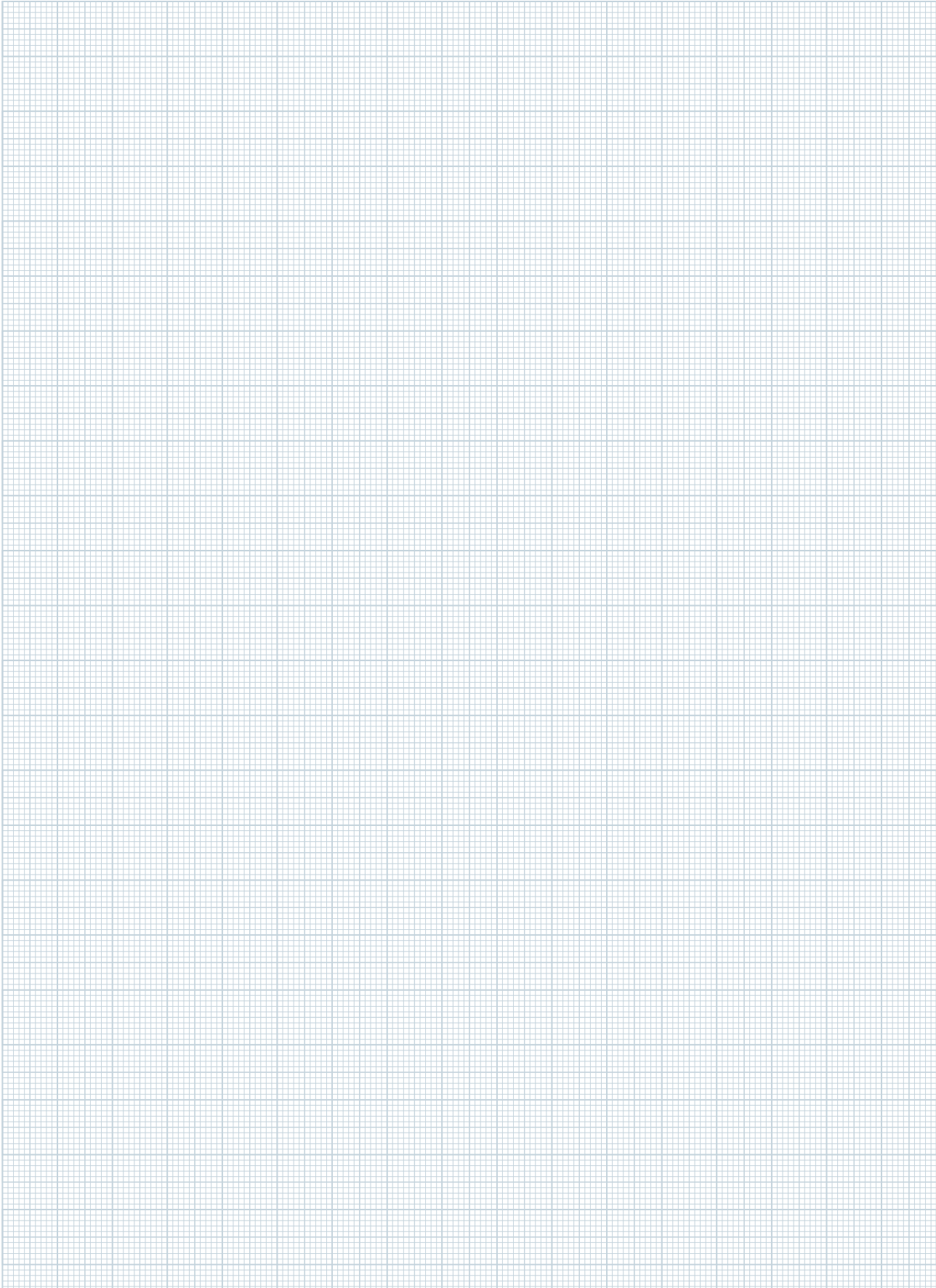

System Overview Overhead Hanger HU 4530/...

SYSTEM	Overhead Hanger	HU 4530/...	Page 100
	Spacer for Overhead Hanger	HDS 45.30...	Page 100
	Protective End Cap	SKU 4530	Page 100
	Bracket	KTA...	Page 101
	Protective End Cap	KA 100-600	Page 101



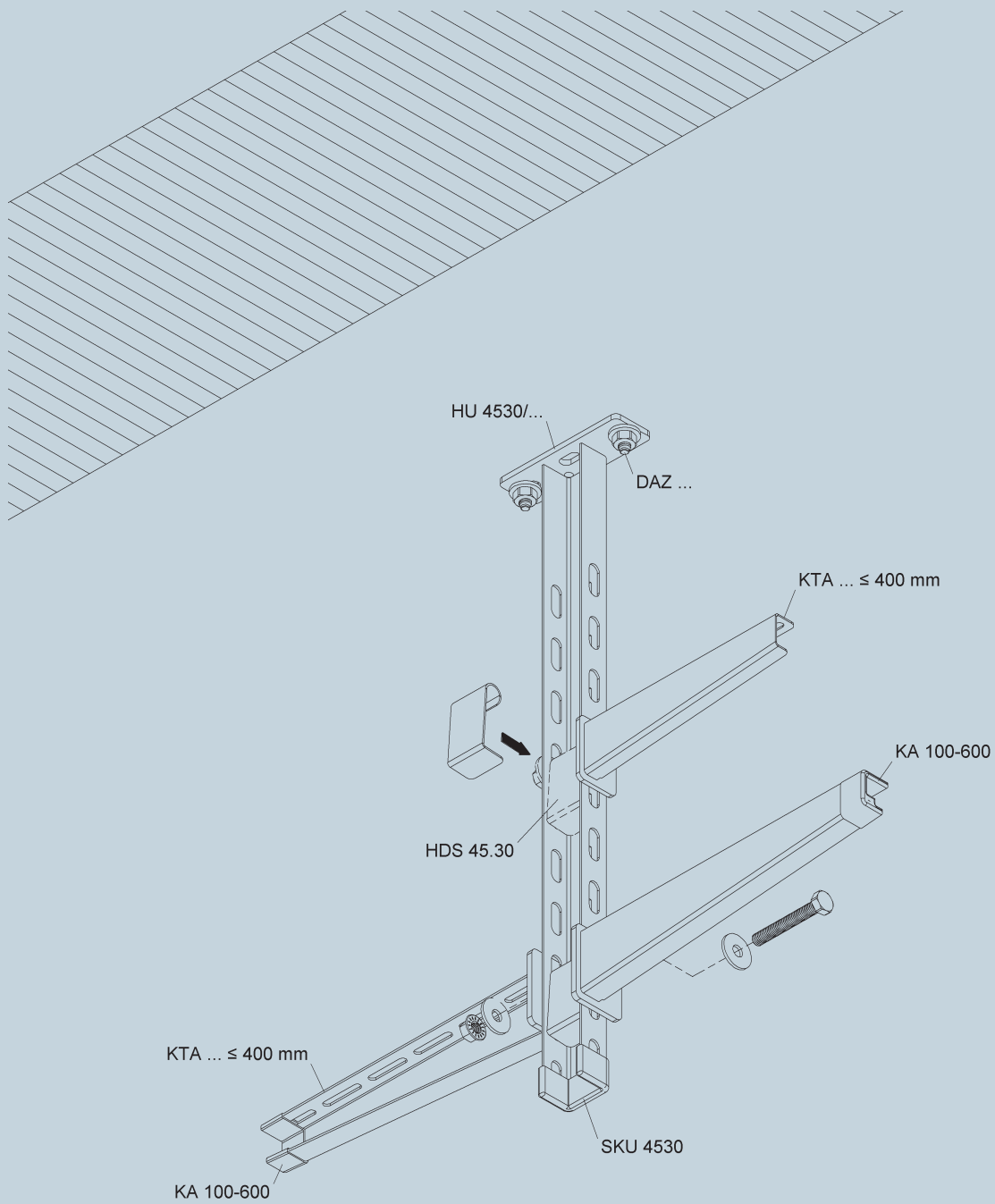

SUPPORT SYSTEM

Overhead Hanger

U-Profile

	Model no.	Total length L		Weight per 100 pcs kg	Pack/Box Qty
		mm	Inch		
F	HU 4530/200 FL	201	7,9	48,83	20
F	HU 4530/250 FL	255	10	56,20	20
F	HU 4530/300 FL	301	11,9	62,25	20
F	HU 4530/400 FL	401	15,8	75,67	20
F	HU 4530/500 FL	501	19,7	89,08	20
F	HU 4530/600 FL	601	23,7	102,50	10
F	HU 4530/700 FL	705	27,8	116,58	1
F	HU 4530/800 FL	805	31,7	129,99	1
E3	HU 4530/200 E3L	201	7,9	44,68	20
E3	HU 4530/300 E3L	301	11,9	56,95	20
E3	HU 4530/400 E3L	401	15,8	69,22	20
E3	HU 4530/500 E3L	501	19,7	81,50	20
E3	HU 4530/600 E3L	601	23,7	93,77	10
E3	HU 4530/700 E3L	705	27,8	106,65	1
E3	HU 4530/800 E3L	805	31,7	118,93	1

Suitable for: bracket KTA... ≤ 400 mm

The load rating shown is valid only for proper anchorage to the building structure. Please consult structural engineering for details and local regulations.

1. Section modulus and moment of inertia are calculated for the perforated section of the profile.

Load Chart: Deflection of Overhead Hanger (onesided load)

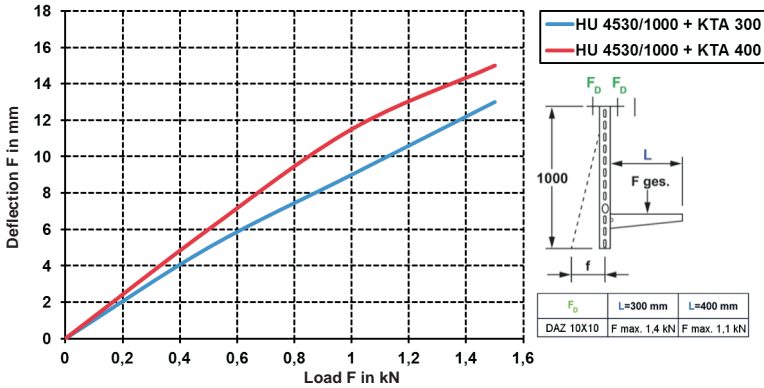

There is no noticeable deflection of the hanger for balanced (twosided) loading.



52

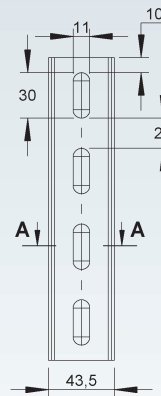
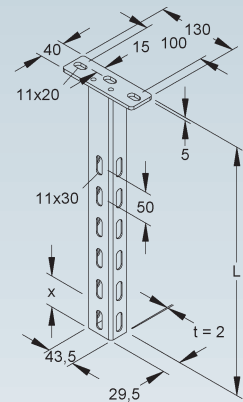

1.

$I_y = 1,34 \text{ cm}^4$
 $I_z = 3,95 \text{ cm}^4$
 $W_y = 0,65 \text{ cm}^3$
 $W_z = 1,81 \text{ cm}^3$

Spacer for Overhead Hanger

	Model no.	Acc. incl.	Weight per 100 pcs kg	Pack/Box Qty
F	HDS 45.30 F	1 SKM 10X80 F, 2 UGM 10 F	14,37	50
E3	HDS 45.30 E3	1 SKM 10X70 E3, 2 UGM 10 E3	13,26	50

Suitable for: overhead hanger HU 4530/...

Please use the HDS... spacer kit to avoid deformation of the U-profile when installing KTA... bracket.



52

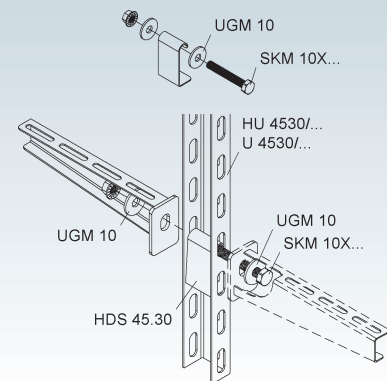

Protective End Cap

	Model no.	Color	Weight per 100 pcs kg	Pack/Box Qty
K03	SKU 4530	yellow	0,95	20

Suitable for: profile U 4530/... and overhead hanger HU 4530/...



52 38 39

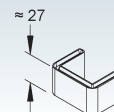

Bracket

standard version

	Model no.	Height H		Width B		Length L		Max. load F at L/2 kN	Acc. incl.	Weight per 100 pcs kg	Pack/ Box Qty
		mm Inch	mm Inch	mm Inch	mm Inch						
F	KTA 100	45 1,8	40 1,6	110 4,3	2,5	2 FLM 6X12	15,52	20			
F	KTA 150	45 1,8	40 1,6	160 6,3	2,5	2 FLM 6X12	19,05	20			
F	KTA 200	55 2,2	40 1,6	210 8,3	2,5	2 FLM 6X12	27,41	20			
F	KTA 250	55 2,2	40 1,6	260 10,2	2,5	2 FLM 6X12	32,21	20			
F	KTA 300	65 2,6	50 2	310 12,2	2,5	2 FLM 6X12	59,08	20			
F	KTA 350	65 2,6	50 2	360 14,2	2,5	2 FLM 6X12	66,35	20			
F	KTA 400	75 3	50 2	410 16,1	2,5	2 FLM 6X12	79,08	20			
E3	KTA 100 E3	45 1,8	40 1,6	110 4,3	2,5	2 FLM 6X12 E3	14,34	20			
E3	KTA 200 E3	55 2,2	40 1,6	210 8,3	2,5	2 FLM 6X12 E3	25,24	20			
E3	KTA 300 E3	65 2,6	50 2	310 12,2	2,5	2 FLM 6X12 E3	54,22	20			
E3	KTA 400 E3	75 3	50 2	410 16,1	2,5	2 FLM 6X12 E3	70,55	20			

for mounting to overhead hangers or for direct wall mount

The load rating shown is valid only for proper anchorage to the building structure. Please consult structural engineering for details and local regulations.



52

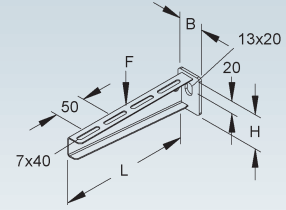

Protective End Cap

	Model no.	Color	Weight per 100 pcs kg	Pack/ Box Qty
K10	KA 100-600	yellow	1,4	10

Suitable for: brackets KTA..., KTT... and KTU...



38



39

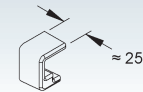

System Overview Overhead Hanger HU 5050/...

SYSTEM	Overhead Hanger	HU 5050/...	Page 104
	Spacer for Overhead Hanger	HDS 50.50 F	Page 104
	Protective End Cap	SKU 5050	Page 104
	Profile U 5050	U 5050/...	Page 105
	Straight Splice Plate	VB 50	Page 105
	Head Plate	KU 5050	Page 105
	Head Plate	KUGV 5050	Page 105
	Bracket	KTA...	Page 106
	Protective End Cap	KA 100-600	Page 106



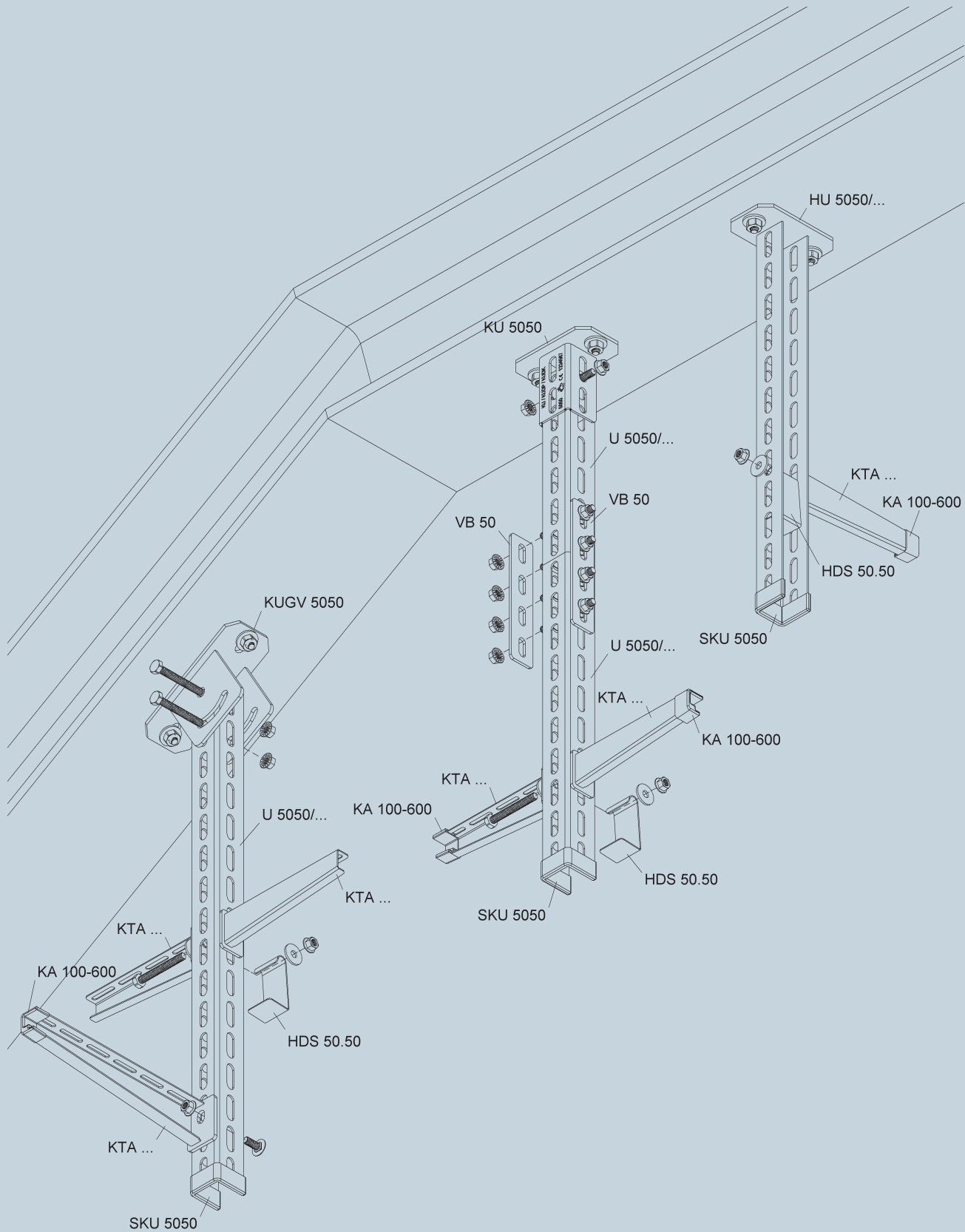

SUPPORT SYSTEM

Overhead Hanger

U-Profile

	Model no.	Total length L		Weight per 100 pcs kg	Pack/Box Qty
		mm	Inch		
F	HU 5050/200	205	8,1	93,08	1
F	HU 5050/250	255	10	105,23	1
F	HU 5050/300	305	12	117,38	1
F	HU 5050/400	405	15,9	141,67	1
F	HU 5050/500	505	19,9	165,97	1
F	HU 5050/600	605	23,8	190,27	1
F	HU 5050/700	705	27,8	214,57	1
F	HU 5050/800	805	31,7	238,87	1
F	HU 5050/900	905	35,6	263,16	1
F	HU 5050/1000	1005	39,6	287,46	1
F	HU 5050/1200	1205	47,4	336,06	1

Suitable for: bracket KTA...

Please use the HDS... spacer kit to avoid deformation of the U-profile when installing KTA... brackets.

Slotted hole size 13x40 mm, 50 mm pitch.

The load rating shown is valid only for proper anchorage to the building structure. Please consult structural engineering for details and local regulations.

1. Section modulus and moment of inertia are calculated for the perforated section of the profile.

Load Chart: Deflection of Overhead Hanger (onesided load)

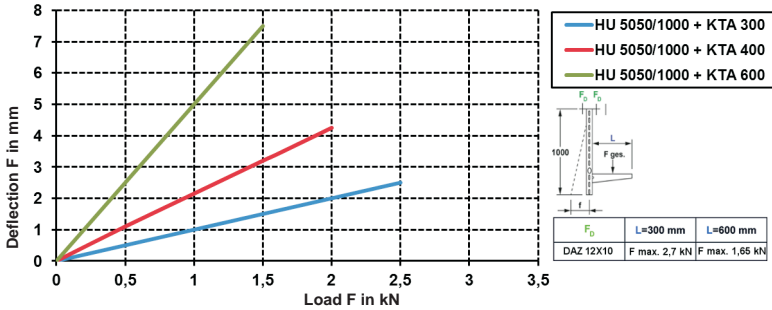

There is no noticeable deflection of the hanger for balanced (twosided) loading.

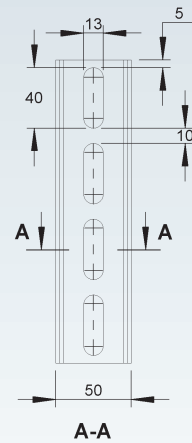
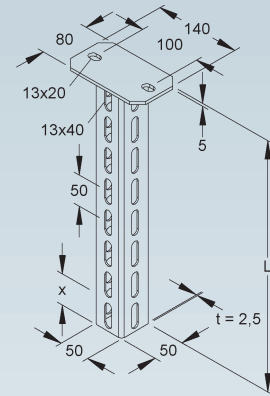

1.

$$I_y = 8 \text{ cm}^4$$

$$I_z = 11,7 \text{ cm}^4$$

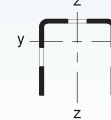

$$W_y = 2,53 \text{ cm}^3$$

$$W_z = 4,7 \text{ cm}^3$$

Spacer for Overhead Hanger

	Model no.	Acc. incl.	Weight per 100 pcs kg	Pack/Box Qty
F	HDS 50.50 F	1 SKM 10X80 F, 2 UGM 10 F	16,52	50

Suitable for: profile U 5050/... and overhead hanger HU 5050/...

Please use the HDS... spacer kit to avoid deformation of the U-profile when installing KTA... bracket.

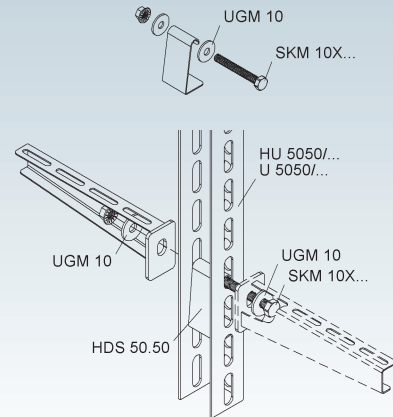

Protective End Cap

	Model no.	Color	Weight per 100 pcs kg	Pack/Box Qty
K03	SKU 5050	yellow	1,38	20

Suitable for: profile U 5050/... and overhead hanger HU 5050/...



≈ 27

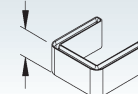

Profile U 5050

	Model no.	Length L		Weight per 100 m kg	Pack/ Box Qty
		mm	Inch		
F	U 5050/3000 F	3000	118,1	242,98	3 m
F	U 5050/6000 F	6000	236,2	242,98	6 m

for building customized overhead hangers, floorstands or support frames

Slotted hole size 13x40 mm, 50 mm pitch.

1. Section modulus and moment of inertia are calculated for the perforated section of the profile.

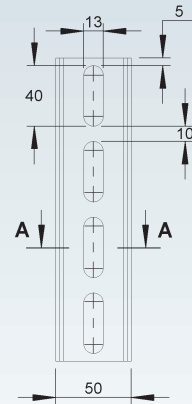
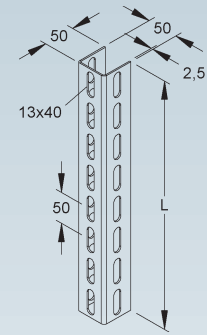

A-A

1.

$$I_y = 8 \text{ cm}^4$$

$$I_z = 11,7 \text{ cm}^4$$

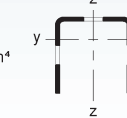

$$W_y = 2,53 \text{ cm}^3$$

$$W_z = 4,7 \text{ cm}^3$$

Straight Splice Plate

	Model no.	Thick- ness t mm	Acc. incl.	Weight per 100 pcs kg	Pack/ Box Qty

Suitable for: profile U 5050/... and overhead hanger HU 5050/...

Slotted hole size 12x30 mm, 50 mm pitch.

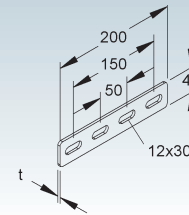

Head Plate

	Model no.	Total length L		Thickness of the head plate t	Acc. incl.	Weight per 100 pcs kg	Pack/ Box Qty	
		mm	Inch					
F	KU 5050	110	4,3	5	0,2	2 FLM 10X25 F	86,33	1

for mounting on horizontal ceilings

Suitable for: profile U 5050/...

Slotted hole size 13x40 mm, 50 mm pitch.

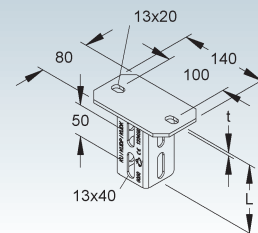

Head Plate

vertical, adjustable from -30° to +30°

	Model no.	Total length L		Thickness of the head plate t	Acc. incl.	Weight per 100 pcs kg	Pack/ Box Qty	
		mm	Inch					
F	KUGV 5050	111	4,4	6	0,2	2 SKM 10X80 F	171,12	1

for mounting on inclined ceilings

Suitable for: profile U 5050/...

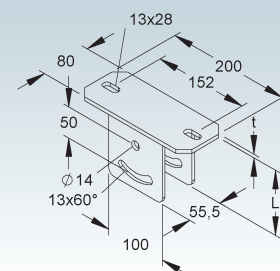

SUPPORT SYSTEM

Bracket

standard version

	Model no.	Height H		Width B		Length L		Max. load F at L/2 kN	Acc. incl.	Weight per 100 pcs kg	Pack/Box Qty
		mm	Inch	mm	Inch	mm	Inch				
F	KTA 100	45	1,8	40	1,6	110	4,3	2,5	2 FLM 6X12	15,52	20
F	KTA 150	45	1,8	40	1,6	160	6,3	2,5	2 FLM 6X12	19,05	20
F	KTA 200	55	2,2	40	1,6	210	8,3	2,5	2 FLM 6X12	27,41	20
F	KTA 250	55	2,2	40	1,6	260	10,2	2,5	2 FLM 6X12	32,21	20
F	KTA 300	65	2,6	50	2	310	12,2	2,5	2 FLM 6X12	59,08	20
F	KTA 350	65	2,6	50	2	360	14,2	2,5	2 FLM 6X12	66,35	20
F	KTA 400	75	3	50	2	410	16,1	2,5	2 FLM 6X12	79,08	20
F	KTA 450	75	3	50	2	460	18,1	2,5	2 FLM 6X12	88,02	10
F	KTA 500	90	3,5	50	2	510	20,1	2,5	2 FLM 6X12	111,01	10
F	KTA 550	90	3,5	50	2	560	22	2,5	2 FLM 6X12	133,95	10
F	KTA 600	90	3,5	50	2	610	24	2,5	2 FLM 6X12	127,42	10

for mounting to overhead hangers or for direct wall mount

The load rating shown is valid only for proper anchorage to the building structure. Please consult structural engineering for details and local regulations.



52

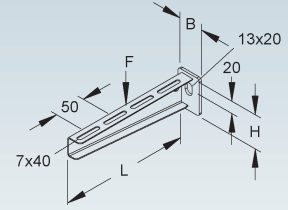

Protective End Cap

	Model no.	Color	Weight per 100 pcs kg	Pack/Box Qty
K10	KA 100-600	yellow	1,4	10

Suitable for: brackets KTA..., KTT... and KTU...



38



39

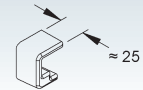

NOTES

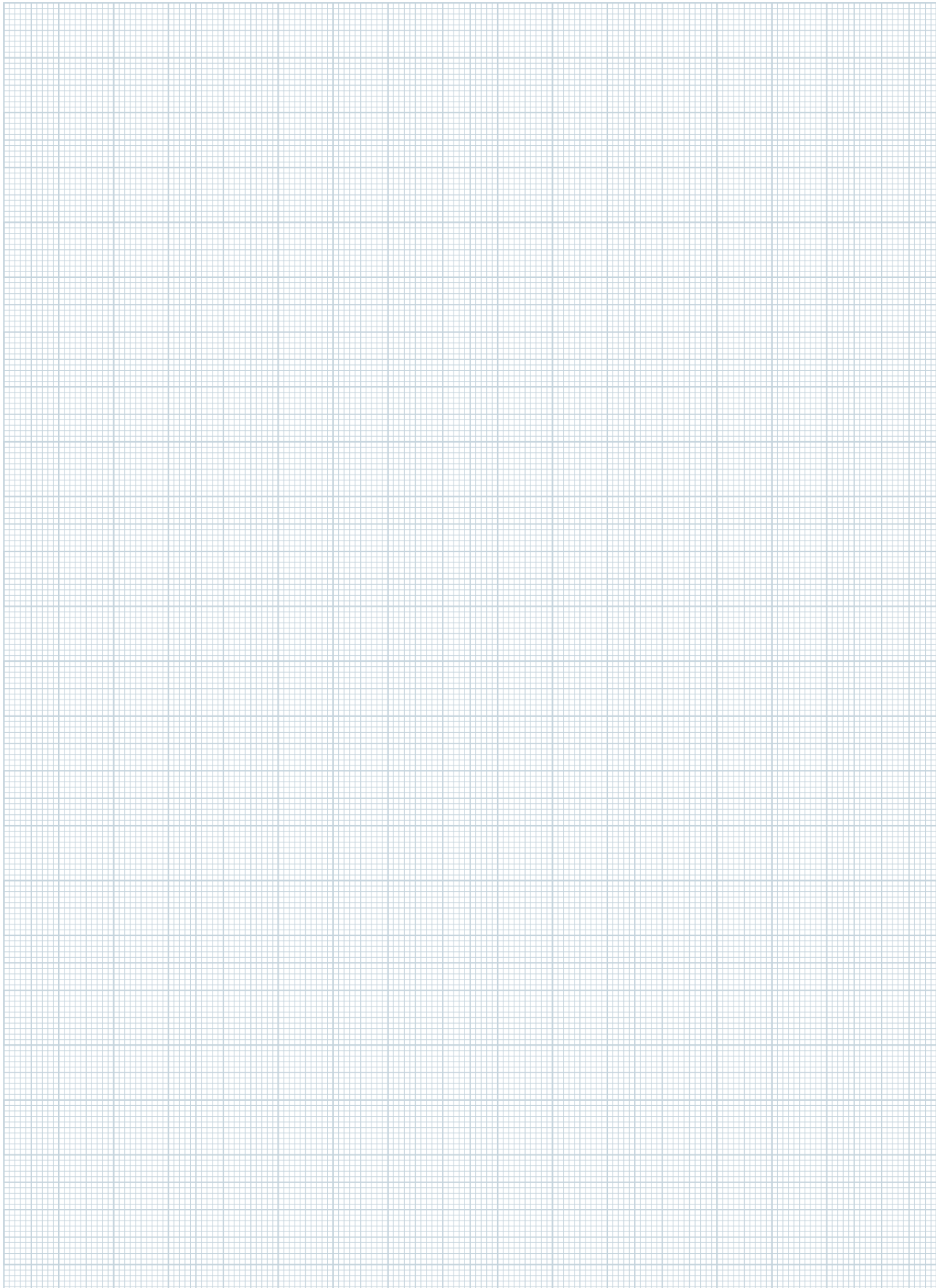

System Overview Overhead Hanger HU 6040/...

SYSTEM	Overhead Hanger	HU 6040/...	Page 110
	Spacer for Overhead Hanger	HDS 60.40...	Page 111
	Protective End Cap	SKU 6040	Page 111
	Profile U 6040	U 6040/...	Page 111
	Straight Splice Plate	VB 6040...	Page 112
	Head Plate	KU 6040...	Page 112
	Heavy Duty I-Beam Clamping Assembly	SPPM 30 F	Page 112
	Heavy Duty I-Beam Clamping Assembly	SPPGM 30 F	Page 113
	Bracket	KTA...	Page 113
	Protective End Cap	KA 100-600	Page 114
	Bracket	KTAS...	Page 114



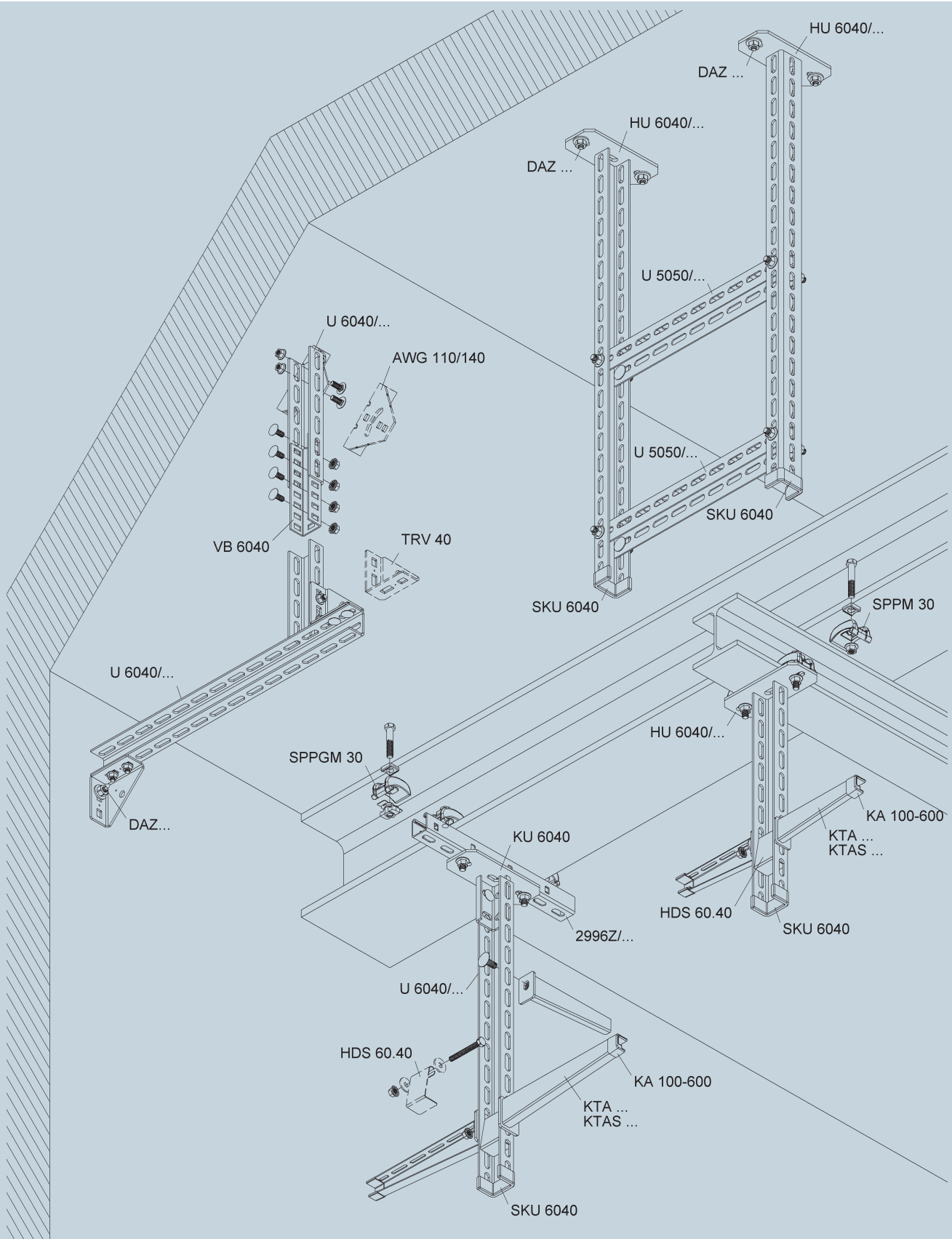

SUPPORT SYSTEM

Overhead Hanger

U-Profile

	Model no.	Total length L		Weight per 100 pcs kg	Pack/Box Qty
		mm	Inch		
F	HU 6040/200	206	8,1	143,21	1
F	HU 6040/250	256	10,1	160,14	1
F	HU 6040/300	306	12	177,08	1
F	HU 6040/400	406	16	210,95	1
F	HU 6040/500	506	19,9	244,82	1
F	HU 6040/600	606	23,9	278,67	1
F	HU 6040/700	706	27,8	312,54	1
F	HU 6040/800	806	31,7	346,41	1
F	HU 6040/900	906	35,7	380,28	1
F	HU 6040/1000	1006	39,6	414,15	1
F	HU 6040/1200	1206	47,5	481,89	1
F	HU 6040/1500	1506	59,3	583,50	1
F	HU 6040/2000	2006	79	752,83	1
E3	HU 6040/200 E3	206	8,1	131,02	1
E3	HU 6040/250 E3	256	10,1	146,51	1
E3	HU 6040/300 E3	306	12	162,00	1
E3	HU 6040/400 E3	406	16	192,99	1
E3	HU 6040/500 E3	506	19,9	223,97	1
E3	HU 6040/600 E3	606	23,9	254,96	1
E3	HU 6040/700 E3	706	27,8	285,94	1
E3	HU 6040/800 E3	806	31,7	316,93	1
E3	HU 6040/900 E3	906	35,7	347,91	1
E3	HU 6040/1000 E3	1006	39,6	378,90	1
E3	HU 6040/1200 E3	1206	47,5	440,87	1
E3	HU 6040/1500 E3	1506	59,3	533,83	1
E3	HU 6040/2000 E3	2006	79	688,75	1

Suitable for: brackets KTA... and KTAS...

Please use the HDS... spacer kit to avoid deformation of the U-profile when installing KTA... and KTAS... brackets.

Slotted hole size 13x40 mm, 50 mm pitch.

The load rating shown is valid only for proper anchorage to the building structure. Please consult structural engineering for details and local regulations.

1. Section modulus and moment of inertia are calculated for the perforated section of the profile.

Load Chart: Deflection of Overhead Hanger (onesided load)

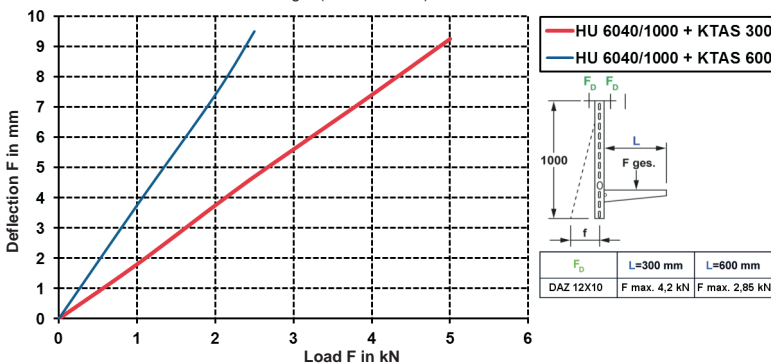

There is no noticeable deflection of the hanger for balanced (twosided) loading.

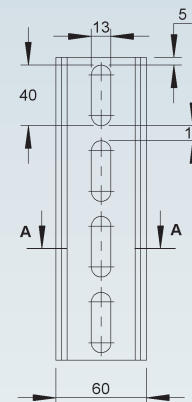
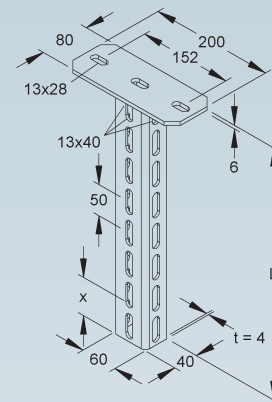

A-A

1.

$I_y = 6,79 \text{ cm}^4$
 $I_z = 19,8 \text{ cm}^4$

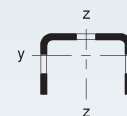

$W_y = 2,52 \text{ cm}^3$
 $W_z = 6,62 \text{ cm}^3$



Spacer for Overhead Hanger

Model no.	Acc. incl.	Weight per 100 pcs kg	Pack/Box Qty
F HDS 60.40 F	1 SKM 10X90 F, 2 UGM 10 F	18,59	50
E3 HDS 60.40 E3	1 SKM 10X90 E3, 2 UGM 10 E3	17,25	50

Suitable for: profile U 6040/... and overhead hanger HU 6040/...
Please use the HDS... spacer kit to avoid deformation of the U-profile when installing KTA... and KTAS... brackets.

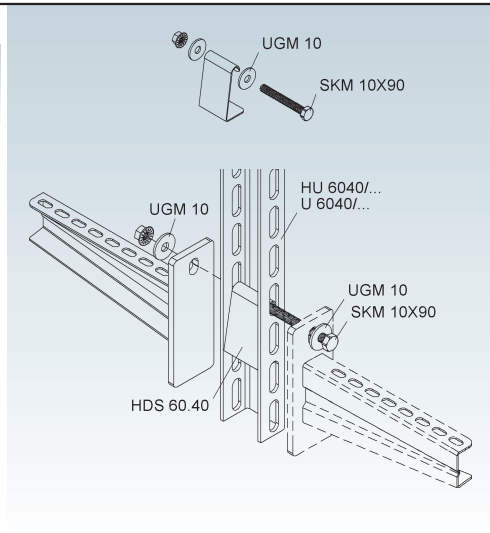

Protective End Cap

Model no.	Color	Weight per 100 pcs kg	Pack/Box Qty
K03 SKU 6040	yellow	1,32	20

Suitable for: profile U 6040/..., overhead hanger HU 6040/... and vertical cable ladder STUC...

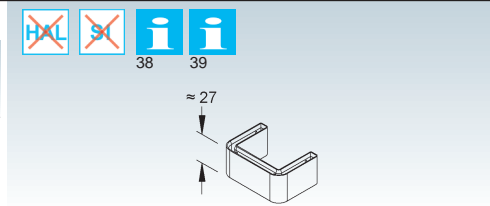

Profile U 6040

Model no.	Length L	Weight per 100 m kg	Pack/Box Qty	mm Inch	
				mm	Inch
F U 6040/3000 F	3000	338,68	3 m	118,1	
F U 6040/6000 F	6000	338,68	6 m	236,2	
E3 U 6040/3000 E3	3000	309,85	3 m	118,1	
E3 U 6040/6000 E3	6000	309,85	6 m	236,2	

for building customized overhead hangers, floorstands or support frames

1. Section modulus and moment of inertia are calculated for the perforated section of the profile.

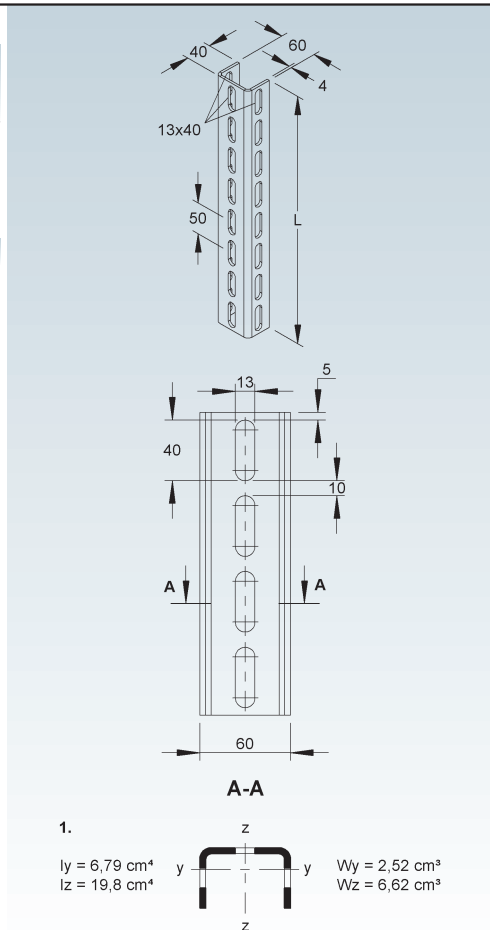

SUPPORT SYSTEM

Straight Splice Plate

	Model no.	Acc. incl.	Weight per 100 pcs kg	Pack/Box Qty
F	VB 6040	4 FLM 10X25 F	61,20	10
E3	VB 6040 E3	4 FLM 10X25 E3	57,63	10

Suitable for: profile U 4530/... and U 6040/...
Slotted hole size 11x18 mm, 25 mm pitch.

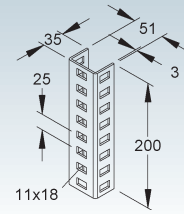

Head Plate

	Model no.	Total length L mm Inch	Thickness of the head plate t mm Inch	Acc. incl.	Weight per 100 pcs kg	Pack/Box Qty
F	KU 6040	106 4,2	6 0,2	2 FLM 10X25 F	118,01	1
E3	KU 6040 E3	106 4,2	6 0,2	2 FLM 10X25 E3	108,63	1

for mounting on horizontal ceilings

Suitable for: profile U 6040/...
Slotted hole size 13x25 mm, 50 mm pitch.

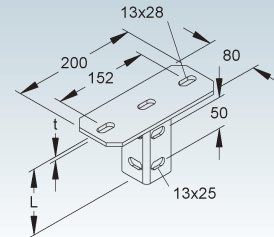

Heavy Duty I-Beam Clamping Assembly

	Model no.	Flange thickness t mm	Acc. incl.	Weight per 100 pair kg	Pack/Box Qty
F	SPPM 30 F	0 - 25	1 SK 12X75 DIN 931	89,34	10 pair

for attaching headplates or hangers directly to I-beams

M12... tightening torque 84 Nm, 18 mm metric wrench.

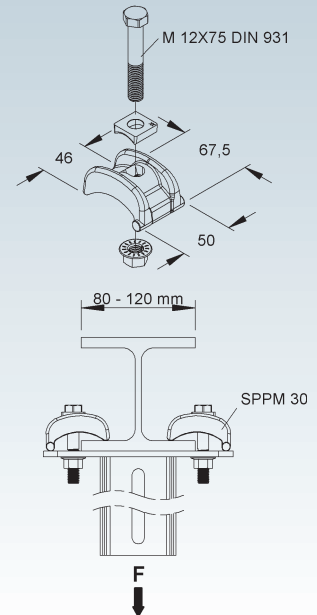
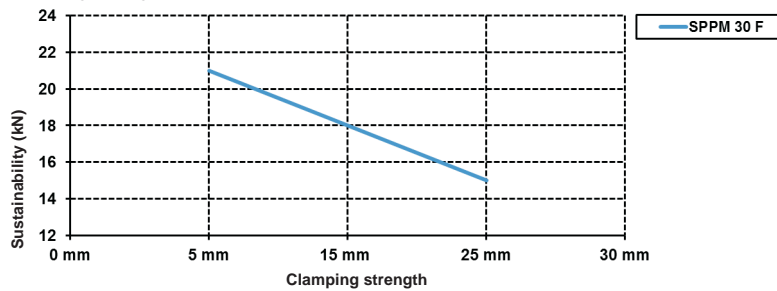

Heavy Duty I-Beam Clamping Assembly

Model no.	Flange thickness t mm	Acc. incl.	Weight per 100 pair kg	Pack/Box Qty
F SPPGM 30 F	0 - 25	1 SK 12X65 DIN 931	91,63	10 pair

for attaching C-rail-mounted headplates or hangers to I-beams

M12... tightening torque 84 Nm, 18 mm metric wrench.

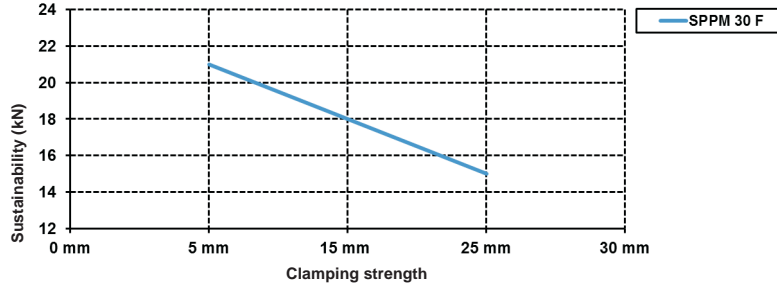

SPPGM 30 F

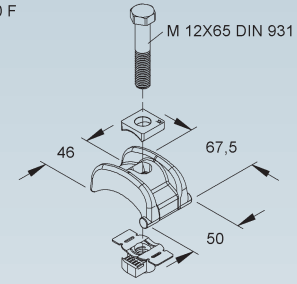

SPPGM 5030 M12 F

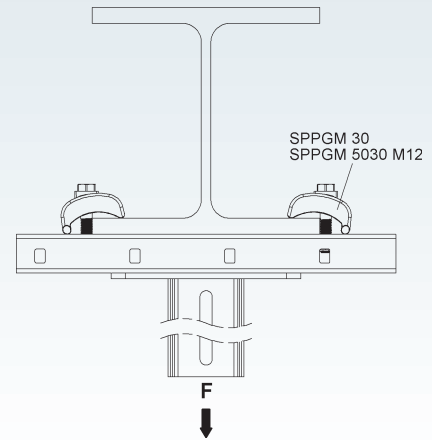
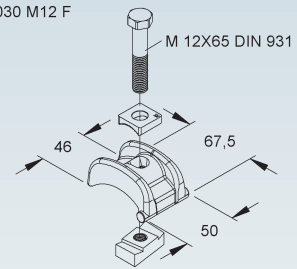

Bracket

standard version

Model no.	Height H mm Inch	Width B mm Inch	Length L mm Inch	Max. load F at L/2 kN	Acc. incl.	Weight per 100 pcs kg	Pack/Box Qty
F KTA 100	45 1,8	40 1,6	110 4,3	2,5	2 FLM 6X12	15,52	20
F KTA 150	45 1,8	40 1,6	160 6,3	2,5	2 FLM 6X12	19,05	20
F KTA 200	55 2,2	40 1,6	210 8,3	2,5	2 FLM 6X12	27,41	20
F KTA 250	55 2,2	40 1,6	260 10,2	2,5	2 FLM 6X12	32,21	20
F KTA 300	65 2,6	50 2	310 12,2	2,5	2 FLM 6X12	59,08	20
F KTA 350	65 2,6	50 2	360 14,2	2,5	2 FLM 6X12	66,35	20
F KTA 400	75 3	50 2	410 16,1	2,5	2 FLM 6X12	79,08	20
F KTA 450	75 3	50 2	460 18,1	2,5	2 FLM 6X12	88,02	10
F KTA 500	90 3,5	50 2	510 20,1	2,5	2 FLM 6X12	111,01	10
F KTA 550	90 3,5	50 2	560 22	2,5	2 FLM 6X12	133,95	10
F KTA 600	90 3,5	50 2	610 24	2,5	2 FLM 6X12	127,42	10
E3 KTA 100 E3	45 1,8	40 1,6	110 4,3	2,5	2 FLM 6X12 E3	14,34	20
E3 KTA 200 E3	55 2,2	40 1,6	210 8,3	2,5	2 FLM 6X12 E3	25,24	20
E3 KTA 300 E3	65 2,6	50 2	310 12,2	2,5	2 FLM 6X12 E3	54,22	20
E3 KTA 400 E3	75 3	50 2	410 16,1	2,5	2 FLM 6X12 E3	70,55	20
E3 KTA 500 E3	90 3,5	50 2	510 20,1	2,5	2 FLM 6X12 E3	108,73	10
E3 KTA 600 E3	110 4,3	50 2	610 24	2,5	2 FLM 6X12 E3	130,39	10

for mounting to overhead hangers or for direct wall mount

The load rating shown is valid only for proper anchorage to the building structure. Please consult structural engineering for details and local regulations.

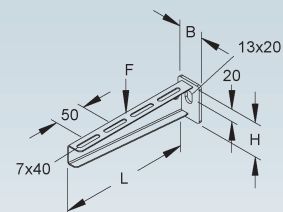

SUPPORT SYSTEM

Protective End Cap

Model no.	Color	Weight per 100 pcs kg	Pack/Box Qty
K10 KA 100-600	yellow	1,4	10

Suitable for: brackets KTA..., KTT... and KTU...

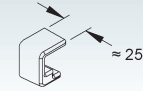

Bracket

heavy-duty

	Model no.	Height H		Length L		Max. load F at L/2 kN	Weight per 100 pcs kg	Pack/Box Qty
		mm	Inch	mm	Inch			
F	KTAS 100	113	4,4	130	5,1	5	89,95	1
F	KTAS 200	113	4,4	230	9,1	5	108,46	1
F	KTAS 300	113	4,4	330	13	5	130,76	1
F	KTAS 400	113	4,4	430	16,9	5	155,40	1
F	KTAS 500	150	5,9	530	20,9	5	197,69	1
F	KTAS 600	150	5,9	630	24,8	5	227,00	1
F	KTAS 700	150	5,9	730	28,7	5	303,23	1
F	KTAS 800	195	7,7	830	32,7	5	364,38	1
F	KTAS 900	195	7,7	930	36,6	5	409,78	1
F	KTAS 1000	195	7,7	1030	40,6	5	458,11	1
E3	KTAS 200 E3	113	4,4	230	9,1	5	99,23	1
E3	KTAS 300 E3	113	4,4	330	13	5	119,63	1
E3	KTAS 400 E3	113	4,4	430	16,9	5	142,17	1
E3	KTAS 500 E3	150	5,9	530	20,9	5	180,87	1
E3	KTAS 600 E3	150	5,9	630	24,8	5	207,67	1

for mounting to overhead hangers or for direct wall mount

The load rating shown is valid only for proper anchorage to the building structure. Please consult structural engineering for details and local regulations.

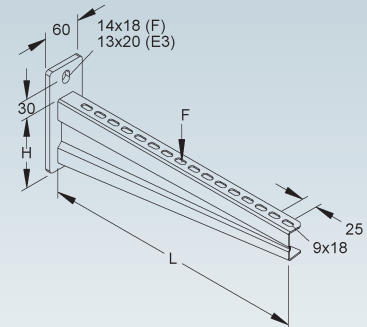

NOTES

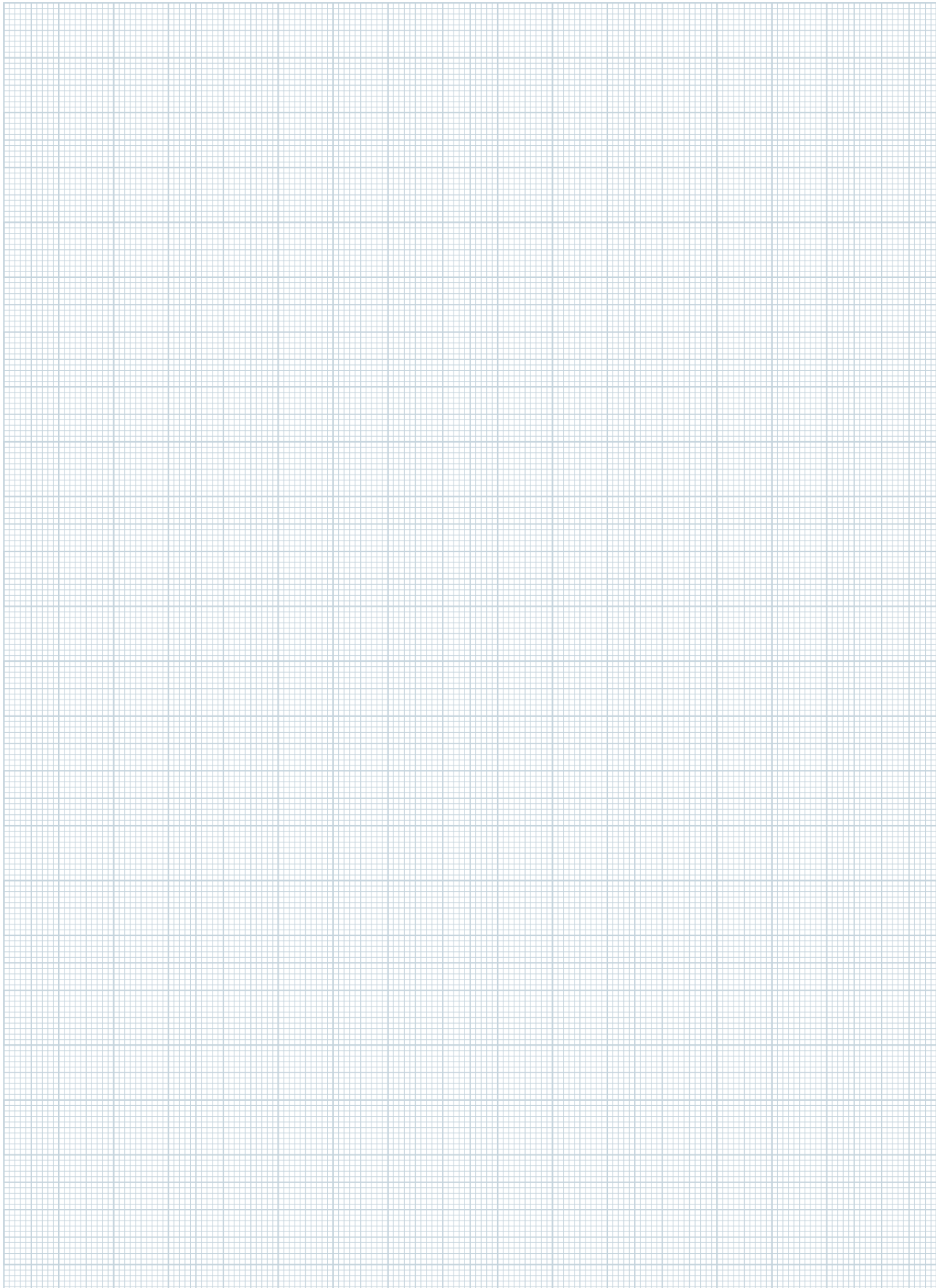

System Overview Overhead Hanger HI 80/...

SYSTEM	Overhead Hanger	HI 80/...	Page 118
	Protective End Cap	SKI 80	Page 118
	Profile I 80	I 80/...	Page 119
	Straight Spice Plate	VBI 80	Page 119
	Tee Connector	VBIQ 80/140	Page 119
	Two Hole Corner Angle for I 80	WWI 80	Page 120
	Head Plate	KI 80	Page 120
	Head Plate	KIQ 80	Page 120
	Head Plate	KIGV 80	Page 120
	Heavy Duty I-Beam Clamping Assembly	SPPM 30 F	Page 121
	Heavy Duty I-Beam Clamping Assembly	SPPGM 30 F	Page 121
	Bracket	KTT...	Page 122
	Protective End Cap	KA 100-600	Page 122
	Bracket	KTTS...	Page 122



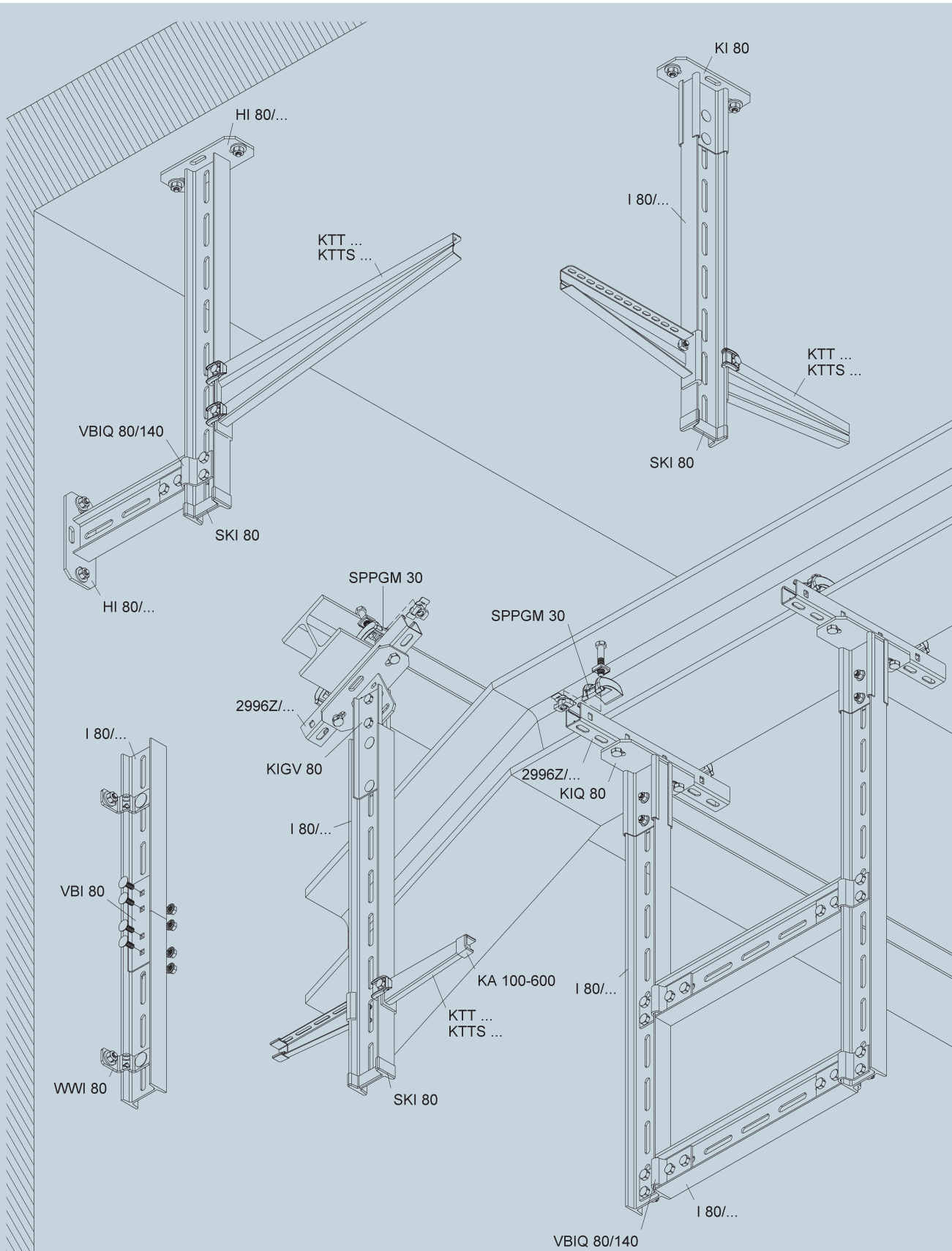

SUPPORT SYSTEM

Overhead Hanger

I 80 profile

	Model no.	Total length L		Weight per 100 pcs kg	Pack/Box Qty
		mm	Inch		
F	HI 80/200	206	8,1	196,99	1
F	HI 80/300	306	12	259,27	1
F	HI 80/400	406	16	321,54	1
F	HI 80/500	506	19,9	383,82	1
F	HI 80/600	606	23,9	446,11	1
F	HI 80/700	706	27,8	508,39	1
F	HI 80/800	806	31,7	570,67	1
F	HI 80/900	906	35,7	632,94	1
F	HI 80/1000	1006	39,6	695,22	1
F	HI 80/1200	1206	47,5	819,79	1
F	HI 80/1500	1506	59,3	1.006,62	1
F	HI 80/2000	2006	79	1.318,02	1

Suitable for: brackets KTT... and KTTS...

The load rating shown is valid only for proper anchorage to the building structure. Please consult structural engineering for details and local regulations.

1. Section modulus and moment of inertia are calculated for the perforated section of the profile.

Load Chart: Deflection of Overhead Hanger (onesided load)

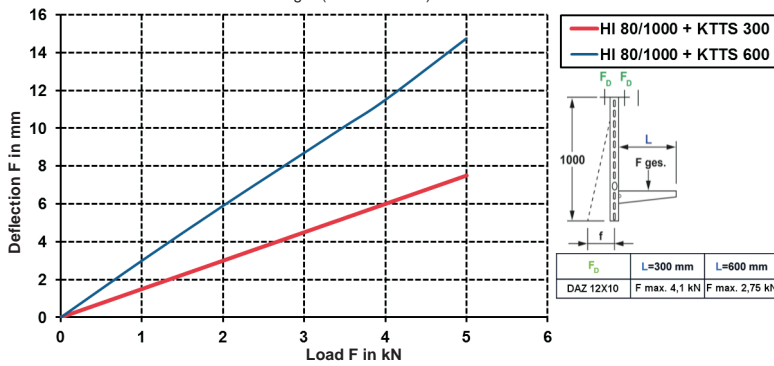

There is no noticeable deflection of the hanger for balanced (twosided) loading.

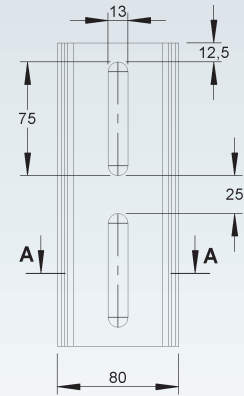
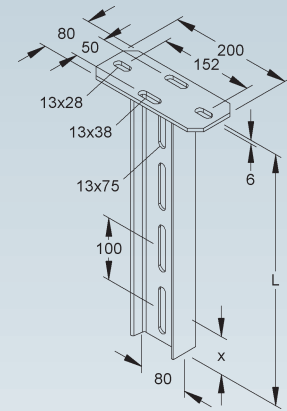

A-A

1.

$$I_y = 6,27 \text{ cm}^4$$

$$I_z = 77,63 \text{ cm}^4$$

$$W_y = 1,49 \text{ cm}^3$$

$$W_z = 19,4 \text{ cm}^3$$

Protective End Cap

Model no.	Color	Weight per 100 pcs kg	Pack/Box Qty
K03 SKI 80	yellow	1,54	20

Suitable for: profile I 80/... as well as overhead hanger HI 80/...



38 39

≈ 27

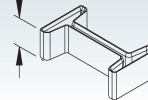

Profile I 80

according to DIN 1025 standard

	Model no.	Length L		Weight per 100 m kg	Pack/Box Qty
		mm	Inch		
F	I 80/3000 FL	3000	118,1	622,8	3 m
F	I 80/6000 FL	6000	236,2	622,8	6 m

for building customized overhead hangers, floorstands or support frames

1. Section modulus and moment of inertia are calculated for the perforated section of the profile.

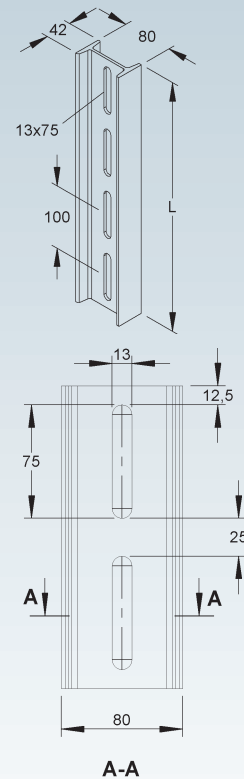

1.

$$I_y = 6,27 \text{ cm}^4$$

$$I_z = 77,63 \text{ cm}^4$$

$$W_y = 1,49 \text{ cm}^3$$

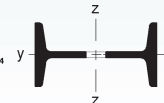
$$W_z = 19,4 \text{ cm}^3$$

Straight Splice Plate

	Model no.	Acc. incl.	Weight per 100 pair kg	Pack/Box Qty
F	VBI 80	4 FLM 10X25 F	75,7	5 pair

2 pieces required per joint

Suitable for: profile I 80/... and overhead hanger HI 80/...

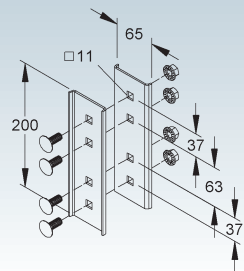

Tee-Connector

	Model no.	Acc. incl.	Weight per 100 pair kg	Pack/Box Qty
F	VBIQ 80/140	4 SKM 12X30 F	90	5 pair

2 pieces required per joint

Suitable for: profile I 80/... and overhead hanger HI 80/...

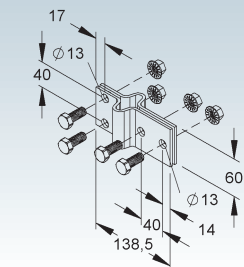

SUPPORT SYSTEM

Two Hole Corner Angle for I 80

equal-sided

Model no.	Acc. incl.	Weight per 100 pcs kg	Pack/Box Qty
F WWI 80	1 FLM 12X30 F	22,69	50

for wall-mounting of profile I 80/...

Suitable for: profile I 80/..., overhead hangers HI 80/... and vertical cable ladders of STIC.... and STIW...

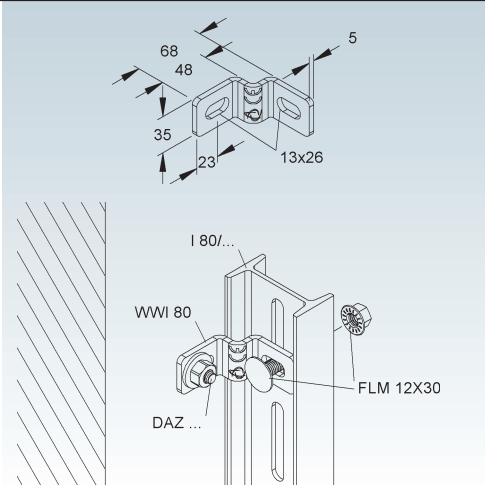

Head Plate

Model no.	Total length L mm Inch	Thickness of the head plate t mm Inch	Acc. incl.	Weight per 100 pcs kg	Pack/Box Qty
F KI 80	151 5,9	6 0,2	2 FLM 10X25 F	135,9	1

for mounting on horizontal ceilings

Suitable for: profile I 80/...

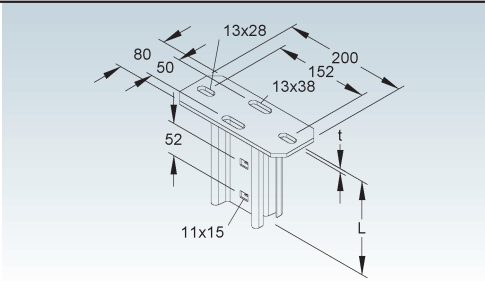

Head Plate

crosswise to profile I 80

Model no.	Total length L mm Inch	Thickness of the head plate t mm Inch	Acc. incl.	Weight per 100 pcs kg	Pack/Box Qty
F KIQ 80	151 5,9	6 0,2	2 FLM 10X25 F	151,76	1

for mounting on horizontal ceilings

Suitable for: profile I 80/...

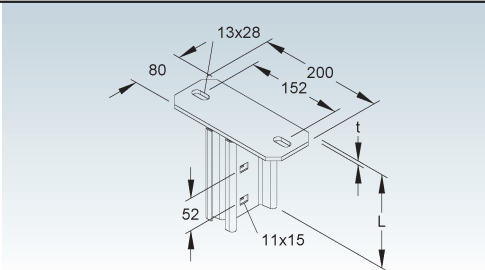

Head Plate

vertical, adjustable from -50° to +50°

Model no.	Total length L mm Inch	Thickness of the head plate t mm Inch	Acc. incl.	Weight per 100 pcs kg	Pack/Box Qty
F KIGV 80	261 10,3	6 0,2	2 FLM 10X25 F	217,09	1

for mounting on inclined ceilings

Suitable for: profile I 80/...

Installation mode: parallel to the support beam
Unit is pre-assembled.

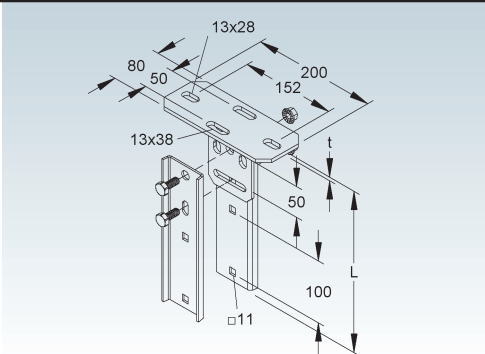

Heavy Duty I-Beam Clamping Assembly

Model no.	Flange thickness t mm	Acc. incl.	Weight per 100 pair kg	Pack/Box Qty
F SPPM 30 F	0 - 25	1 SK 12X75 DIN 931	89,34	10 pair

for attaching headplates or hangers directly to I-beams
M12... tightening torque 84 Nm, 18 mm metric wrench.

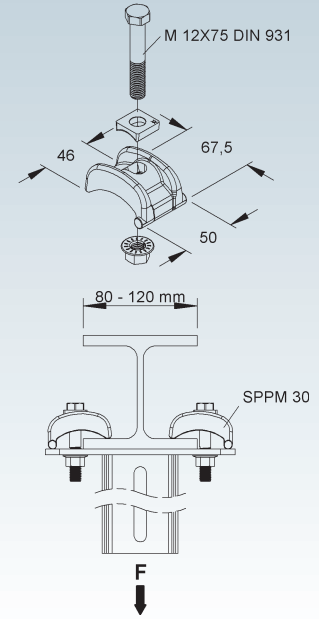
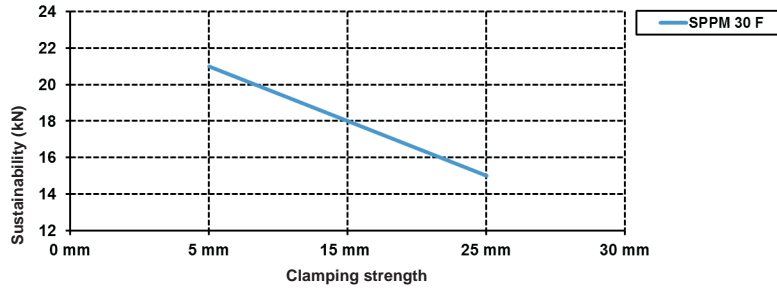

Heavy Duty I-Beam Clamping Assembly

Model no.	Flange thickness t mm	Acc. incl.	Weight per 100 pair kg	Pack/Box Qty
F SPPGM 30 F	0 - 25	1 SK 12X65 DIN 931	91,63	10 pair

for attaching C-rail-mounted headplates or hangers to I-beams
M12... tightening torque 84 Nm, 18 mm metric wrench.

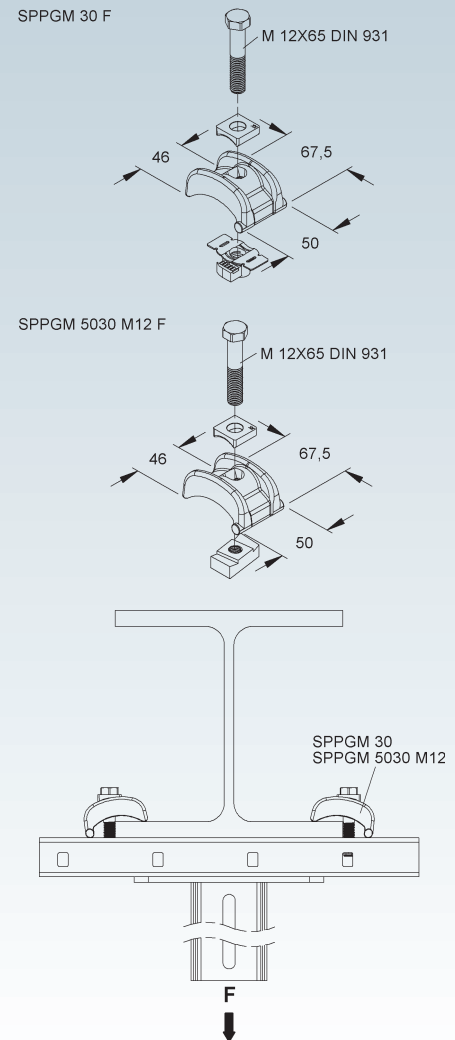
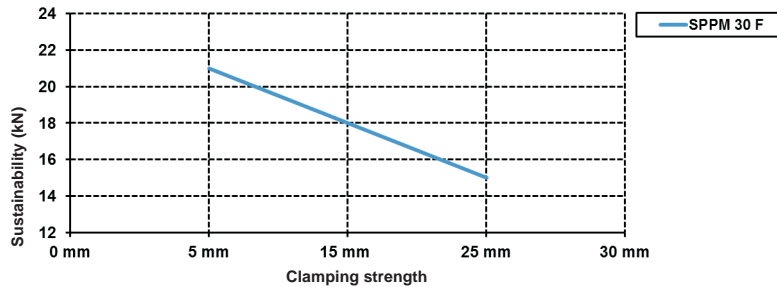

SUPPORT SYSTEM

Bracket

standard version, with pre-assembled clamp

	Model no.	Height H		Length L		Max. load F at L/2 kN	Acc. incl.	Weight per 100 pcs kg	Pack/Box Qty
		mm	Inch	mm	Inch				
F	KTT 100	55	2,2	110	4,3	2,5	2 FLM 6X12	36,72	20
F	KTT 150	55	2,2	160	6,3	2,5	2 FLM 6X12	39,99	20
F	KTT 200	55	2,2	210	8,3	2,5	2 FLM 6X12	47,23	20
F	KTT 250	75	3	260	10,2	2,5	2 FLM 6X12	56,52	20
F	KTT 300	75	3	310	12,2	2,5	2 FLM 6X12	76,99	20
F	KTT 350	75	3	360	14,2	2,5	2 FLM 6X12	84,01	20
F	KTT 400	95	3,7	410	16,1	2,5	2 FLM 6X12	96,35	20
F	KTT 450	95	3,7	460	18,1	2,5	2 FLM 6X12	105,04	10
F	KTT 500	95	3,7	510	20,1	2,5	2 FLM 6X12	124,36	10
F	KTT 550	95	3,7	560	22	2,5	2 FLM 6X12	147,29	10
F	KTT 600	95	3,7	610	24	2,5	2 FLM 6X12	140,77	10

Suitable for: profile I 80/... as well as overhead hanger HI 80/...

The load rating shown is valid only for proper anchorage to the building structure. Please consult structural engineering for details and local regulations.

Hardware for mounting cable ladders has to be ordered separately.

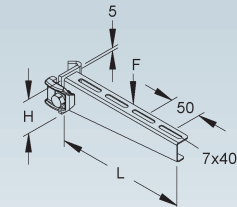

Protective End Cap

	Model no.	Color	Weight per 100 pcs kg	Pack/Box Qty

Suitable for: brackets KTA..., KTT... and KTU...

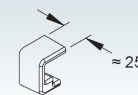

Bracket

heavy-duty, with pre-assembled clamp

	Model no.	Height H		Length L		Max. load F at L/2 kN	Weight per 100 pcs kg	Pack/Box Qty
		mm	Inch	mm	Inch			
F	KTTS 200	110	4,3	230	9,1	5	88,18	1
F	KTTS 300	110	4,3	330	13	5	110,47	1
F	KTTS 400	110	4,3	430	16,9	5	135,11	1
F	KTTS 500	150	5,9	530	20,9	5	173,46	1

Suitable for: profile I 80/... and overhead hanger HI 80/...

The load rating shown is valid only for proper anchorage to the building structure. Please consult structural engineering for details and local regulations.

Hardware for mounting cable ladders has to be ordered separately.

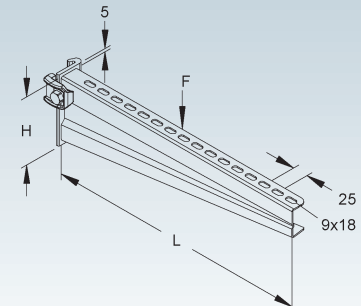

Bracket

heavy-duty, with pre-assembled clamp

	Model no.	Height H		Length L		Max. load F at L/2 kN	Weight per 100 pcs kg	Pack/Box Qty
		mm	Inch	mm	Inch			
F	KTTS 600	150	5,9	630	24,8	5	215,62	1
F	KTTS 700	150	5,9	730	28,7	5	291,78	1
F	KTTS 800	190	7,5	830	32,7	5	345,64	1
F	KTTS 900	190	7,5	930	36,6	5	391,06	1
F	KTTS 1000	190	7,5	1030	40,6	5	439,38	1

Suitable for: profile I 80/... and overhead hanger HI 80/...

The load rating shown is valid only for proper anchorage to the building structure. Please consult structural engineering for details and local regulations.

Hardware for mounting cable ladders has to be ordered separately.

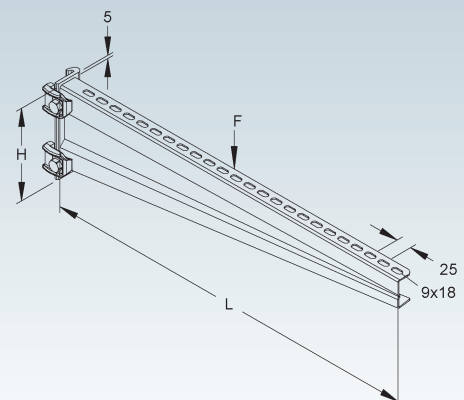

NOTES

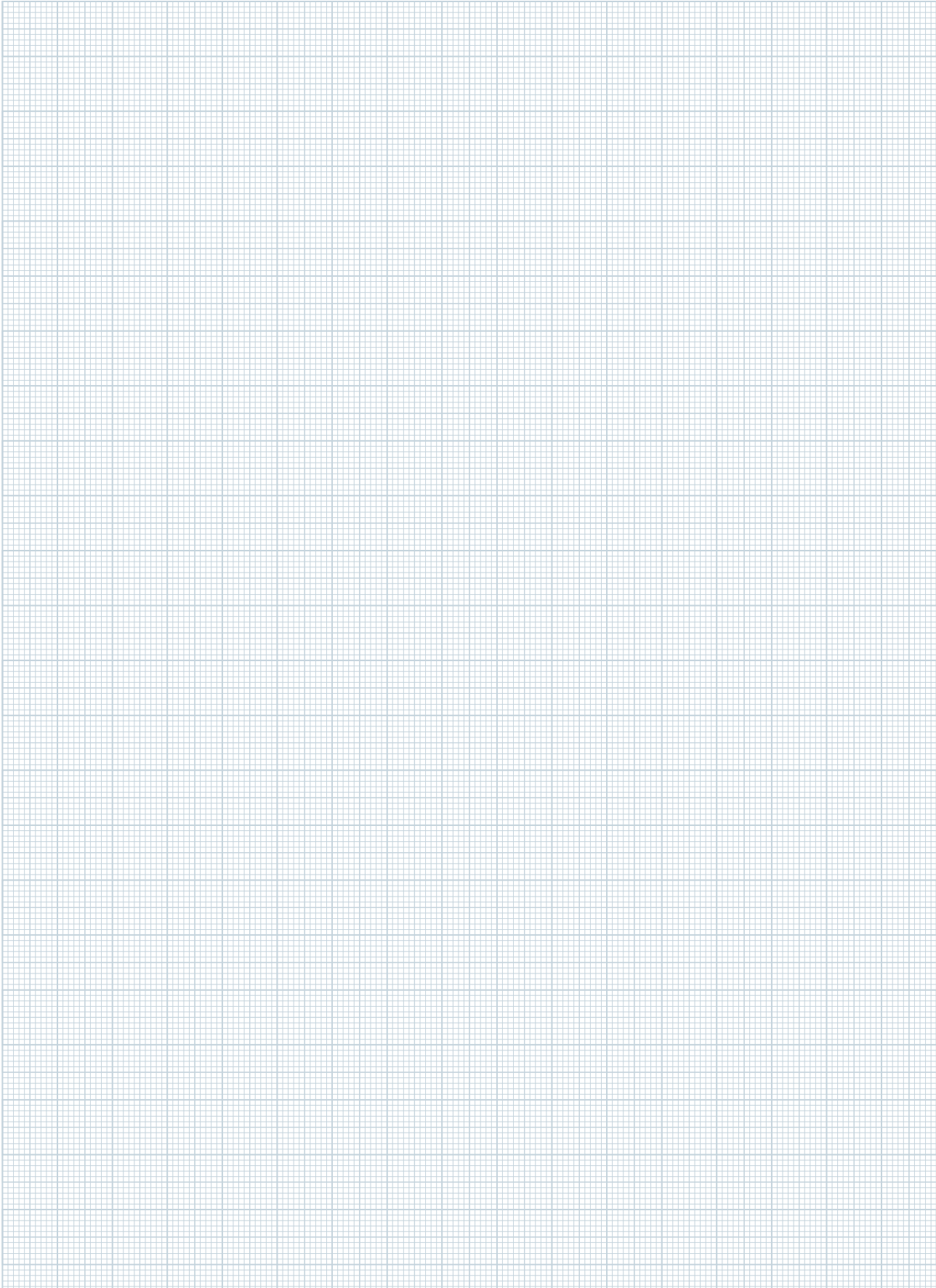

Channels, Rails, Clamps and Accessories

ACCESSORIES	2970 Framing Channel	2970/2 SL	Page 128
	Protective End Cap	SKSP 70	Page 128
	Sloped Sliding Nut	GSM... , GSF...	Page 128
	2986 Framing Channel	2986/...	Page 129
	Protective End Cap	SKC 86	Page 130
	Channel Nut	GMZ...	Page 129/134
	Gripping Channel Nut	GMZF...	Page 129/134
	2997Z Framing Channel	2997Z/3 FL	Page 130
	2996Z Toothed Framing Channel	2996Z/..., 2996Z-2.0...	Page 130/131
	2996ZD Toothed Framing Channel	2996ZD/3 FL	Page 131
	Protective End Cap	SKC 88/96	Page 131
	Protective End Cap	SKCED 96	Page 132
	Straight Strut Joiner	SSV 4141 F	Page 132
	Flanged U-Washer	SGP 41 F	Page 132
	Three Hole Splice Plate	SVL 41 F	Page 132
	Three Hole Corner Plate	SWS 41 F	Page 133
	Four Hole Tee Plate	STS 41 F	Page 133
	Five Hole U-Support	SBB 41 F	Page 133
	Beam Clamp	HSK.../HSKS...	Page 134/135
	I-Beam Clamping Assembly	SPKM 25 F/SPKGM 25 F	Page 135/136
	Heavy Duty I-Beam Clamping Assembly	SPPM 30 F/SPPGM 30 F	Page 136/137
	Two Hole Corner Angle	WWU 150	Page 137
	Three Hole Corner Angle	WWA 100...	Page 138
	Shelf Bracket	TRV 40...	Page 138
	Adjustable Corner Bracket	AWG 110/140...	Page 138
	Heavy Duty Square Washer / Anchor Plate	VP 50.50	Page 138
	Column Support Bracket	TZK 86-96 S	Page 139
	Flange Clamp	PKS...	Page 139
	Beam Clamp with Locknut	FC...	Page 140
	Hammerset Flange Clip	AH..., EH...	Page 140/141
	Hex Head Bolt	SK...	Page 141
	Socket Cap Bolt	M...	Page 141
	Serrated Flange Nut	SMF...	Page 141
	Hex Head Bolt with Nut	SKM...	Page 141
	Carriage Bolt with Nut	FLM...	Page 132/142
	Carriage Bolt with Shaft and Nut	FLDM...	Page 142
	Threaded Rod	M 6/..., M 8/..., M 10/..., M 12/...	Page 142/143
	Large Diameter Washer	UGM...	Page 143
	Washer according to DIN EN ISO 7089 standard	US M...	Page 143
	Hexagonal Nut	SMU...	Page 144
	Hexagonal Rod Coupling	VBSM...	Page 144
	Serrated Washer	ZS...	Page 144
	Expansion Anchor	DAM..., DAZ...	Page 144/145
	Concrete Screw Anchor	NSA 7.5X50/FGK-T30 V	Page 145
	Edge Protection Strip	RKBA...	Page 145
	Edge Protection Ring	KSR...	Page 146
	Punch and Die Set for Hydraulic Tools	W-BL...	Page 146
	Yoke-Clamp	BK..., BUK..., BWK...	Page 147
	Counter Pressure Cradle for all Yoke-Clamps	GWU...	Page 148

NOTES

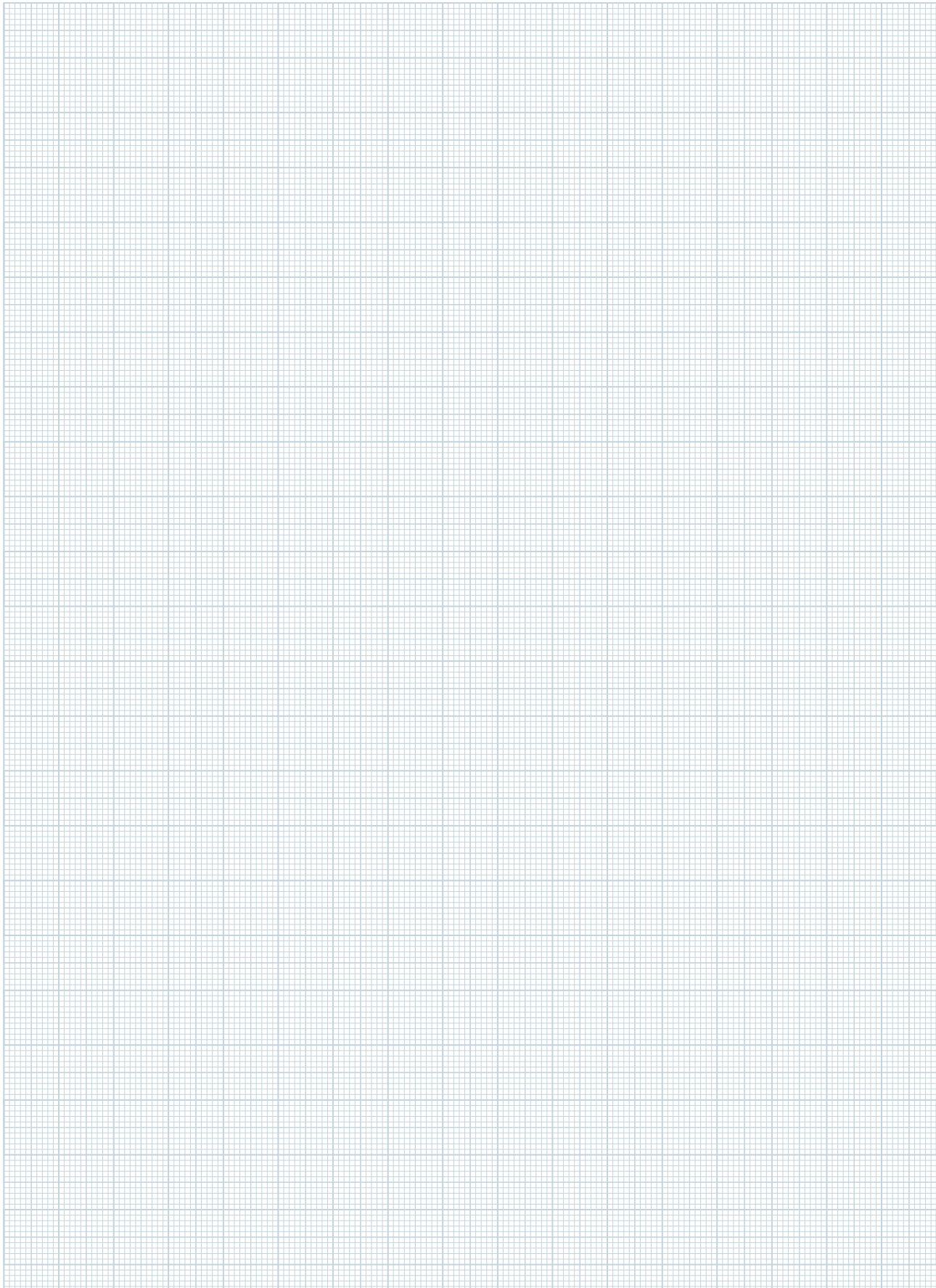

SUPPORT SYSTEM

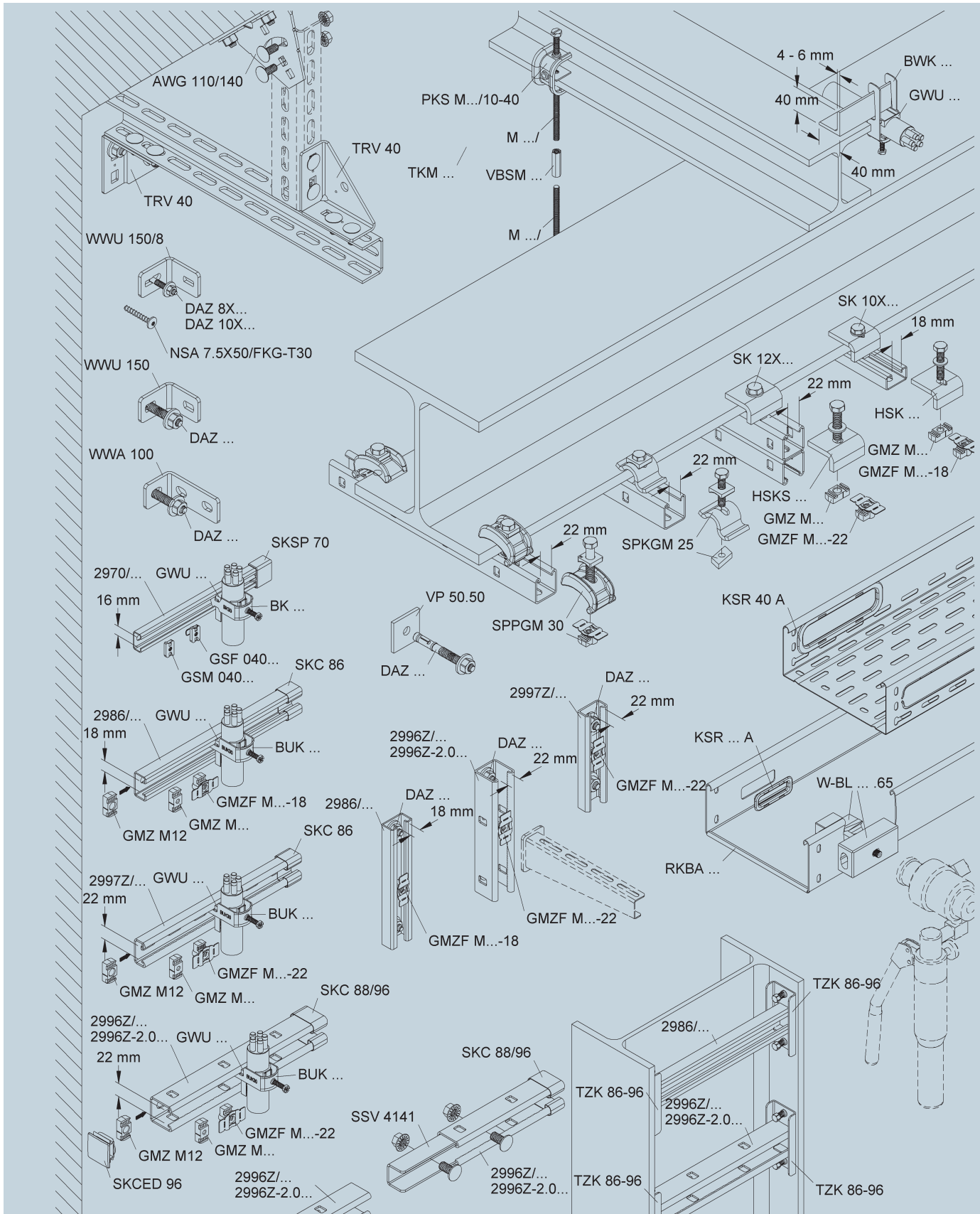

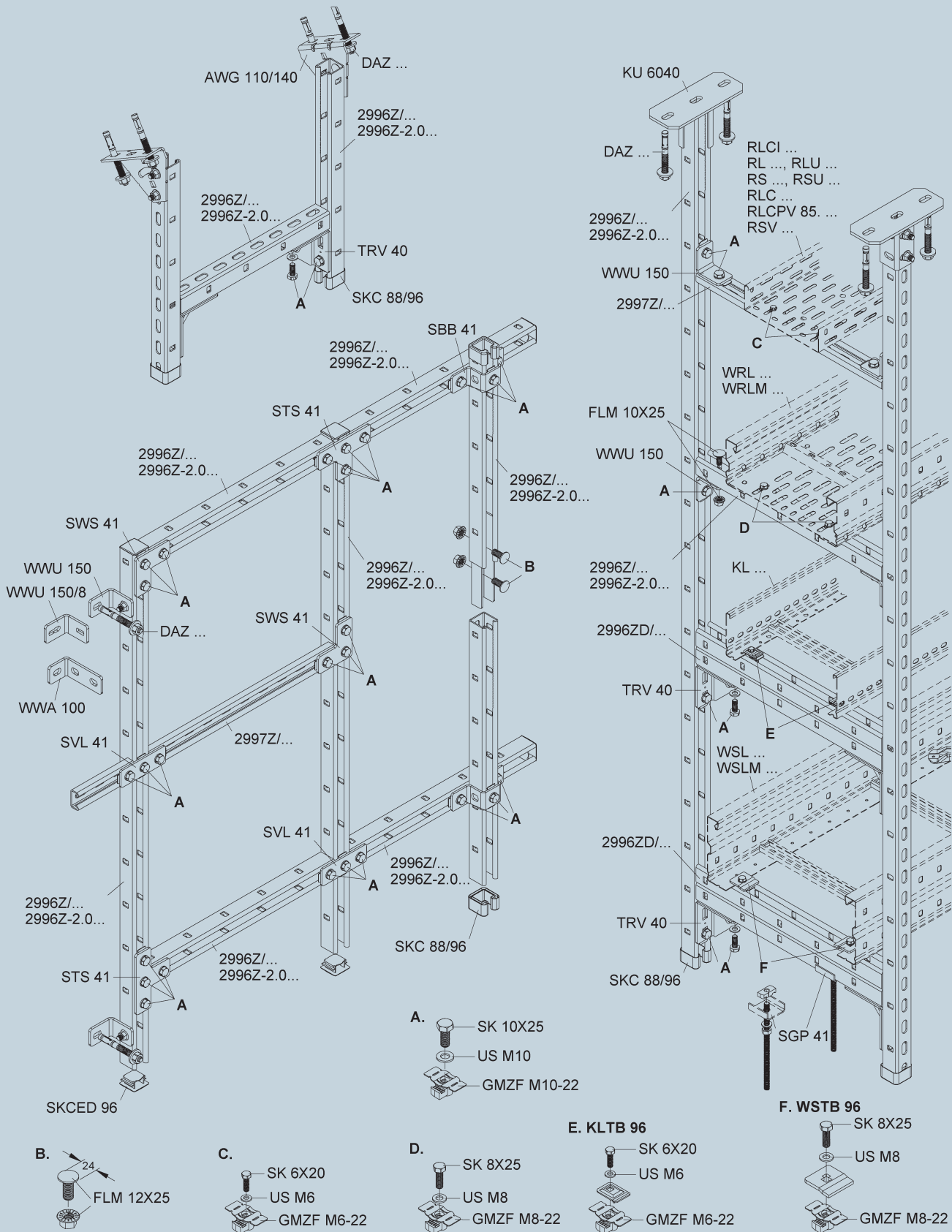

SUPPORT SYSTEM

2970 Framing Channel

slot width 16 mm, perforated, according to DIN EN 60715 standard

Model no.	Length L	Perforation	Distance between drill holes	Weight per 100 m	Pack/ Box Qty
	mm Inch	mm	mm Inch	m kg	
S 2970/2 SL	2000 78,7	9x15	25 1	69,94	10 x 2 m

matching yoke-clamp BK...

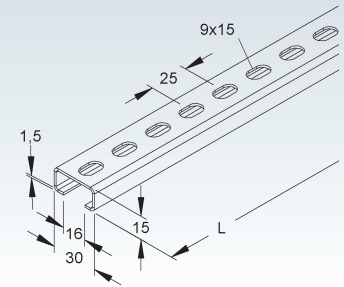
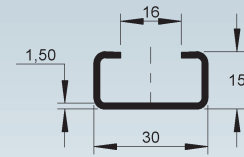

Protective End Cap

Model no.	Height H	Color	Weight per 100 pcs	Pack/ Box Qty
	mm Inch		kg	
K04 SKSP 70	15 0,6	grey	0,57	20

Suitable for: framing channel 2970... and SP 70 rungs

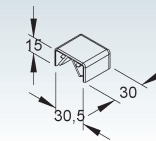

Sloped Sliding Nut

Model no.	Thread M	Height H	Weight per 100 pcs	Pack/ Box Qty
		mm Inch	kg	
G GSM 0406	6	4 0,2	1,01	50
G GSM 0408	8	4 0,2	0,95	50

Suitable for: framing channel 2970... (16 mm slotwidth)
Insertable at any position of the framing channel.

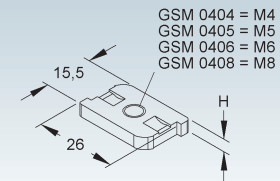

Sloped Sliding Nut

with clamping spring

Model no.	Thread M	Height H	Weight per 100 pcs	Pack/ Box Qty
		mm Inch	kg	
G GSF 0406	6	4 0,2	1,11	25
G GSF 0408	8	4 0,2	1,05	25

Suitable for: framing channel 2970... (16 mm slotwidth)
Insertable at any position of the framing channel.

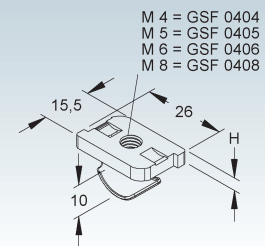

2986 Framing Channel

C-profile, slot width 18 mm, perforated, according to DIN EN 60715 standard

	Model no.	Length L		Perforation mm	Distance between drill holes		Weight per 100 pcs/m kg	Pack/ Box Qty
		mm	Inch		mm	Inch		
S	2986/200 SL	200	7,9	11,5x30	50	2	29,81	1
S	2986/300 SL	300	11,8	11,5x30	50	2	44,72	1
S	2986/400 SL	400	15,7	11,5x30	50	2	59,63	1
S	2986/500 SL	500	19,7	11,5x30	50	2	74,53	1
S	2986/600 SL	600	23,6	11,5x30	50	2	89,44	1
S	2986/700 SL	700	27,6	11,5x30	50	2	104,35	1
S	2986/800 SL	800	31,5	11,5x30	50	2	119,25	1
S	2986/900 SL	900	35,4	11,5x30	50	2	134,16	1
S	2986/1000 SL	1000	39,4	11,5x30	50	2	149,07	1
S	2986/3 SL	3000	118,1	11,5x30	50	2	149,07	5 x 3 m
F	2986/3 FL	3000	118,1	11,5x30	50	2	163,97	5 x 3 m
E3	2986/3 E3L	3000	118,1	11,5x30	50	2	150,02	5 x 3 m

matching yoke-clamp BUK...

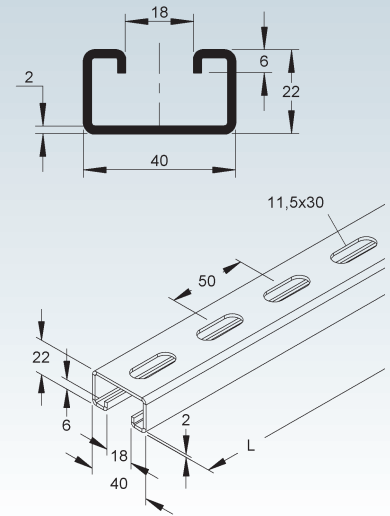

Channel Nut

	Model no.	Thread M	Strength category	Weight per 100 pcs kg	Pack/ Box Qty
F	GMZ M6 F	6	8	3,5	100
F	GMZ M8 F	8	8	3,3	100
F	GMZ M10 F	10	8	3,2	100
F	GMZ M12 F	12	8	3,5	100

Suitable for: framing channel 2986... (18 mm slotwidth), 2996Z... and 2997Z... (22 mm slotwidth)
The GMZ M12 F can only be inserted from the end of the 2986... framing channel.

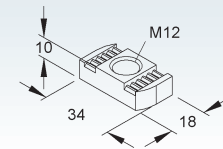
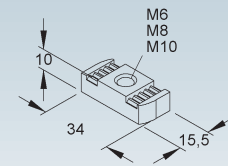

Gripping Channel Nut

	Model no.	Thread M	Strength category	Weight per 100 pcs kg	Pack/ Box Qty
F	GMZF M6-18 F	6	8	3,66	100
F	GMZF M8-18 F	8	8	3,52	100
F	GMZF M10-18 F	10	8	3,36	100
F	GMZF M12-18 F	12	8	3,71	100
E5	GMZF M6-18 E5	6	1.4571	3,72	100
E5	GMZF M8-18 E5	8	1.4571	3,58	100
E5	GMZF M10-18 E5	10	1.4571	3,41	100
E5	GMZF M12-18 E5	12	1.4571	3,77	100

Suitable for: framing channel 2986... (18 mm slotwidth)
The GMZF M12-18 F can only be inserted from the end of the 2986... framing channel.

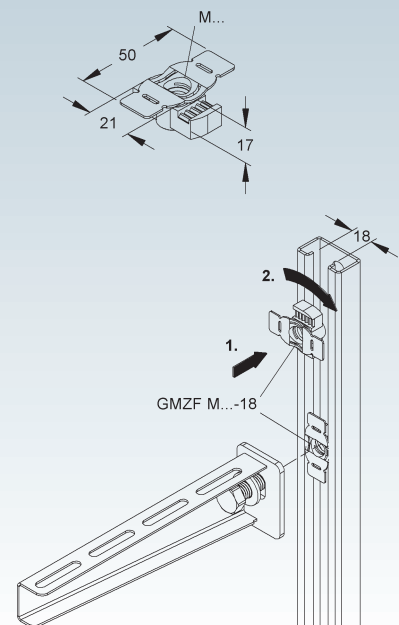

SUPPORT SYSTEM

2997Z Framing Channel

C-profile, slot width 22 mm, perforated

Model no.	Length L	Perforation	Distance between drill holes	Weight per 100 m kg	Pack/ Box Qty
	mm Inch	mm	mm Inch		
F 2997Z/3 FL	3000 118,1	13x30	50 2	184,33	3 m

The combination of the toothed channel with the GMZ M... and GMZ F M... channel nuts guarantees higher load ratings.

matching yoke-clamp BUK...

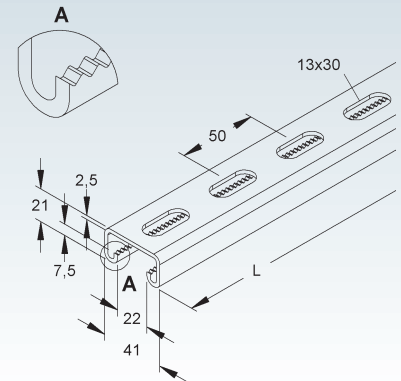
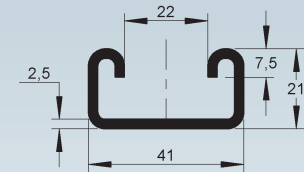

Protective End Cap

Model no.	Color	Weight per 100 pcs kg	Pack/ Box Qty
K03 SKC 86	yellow	0,79	20

Suitable for: framing channel 2986... and 2997Z/...



38 39

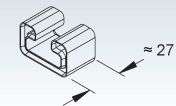

2996Z Toothed Framing Channel

slot width 22 mm, perforated

Model no.	Length L	Perforation	Distance between drill holes	Dimension siderail holes	Distance between siderail holes	Weight per 100 m kg	Pack/ Box Qty
	mm Inch	mm	mm Inch	mm	mm Inch		
F 2996Z/3 FL	3000 118,1	13x30	50 2	11x15	100 3,9	265,13	3 m
E3 2996Z/3 E3L	3000 118,1	13x30	50 2	11x15	100 3,9	242,25	3 m

The combination of the toothed channel with the GMZ M... and GMZ F M... channel nuts guarantees higher load ratings.

matching yoke-clamp BUK...

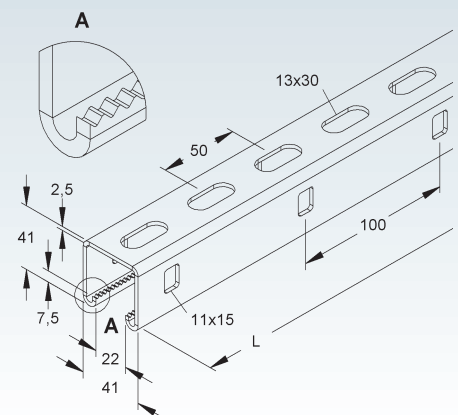
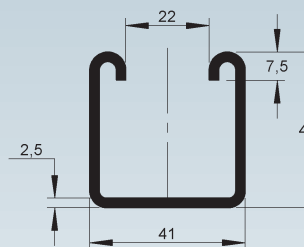

2996Z Toothed Framing Channel

Model no.	Length L	Perforation	Distance between drill holes	Dimension siderail holes	Distance between siderail holes	Weight per 100 m kg	Pack/ Box Qty
	mm Inch	mm	mm Inch	mm	mm Inch		
S 2996Z-2.0/3 SL	3000 118,1	13x30	50 2	11x15	100 3,9	197,06	3 m
F 2996Z-2.0/3 FL	3000 118,1	13x30	50 2	11x15	100 3,9	216,77	3 m

The combination of the toothed channel with the GMZ M... and GMZ F M... channel nuts guarantees higher load ratings.
matching yoke-clamp BUK...

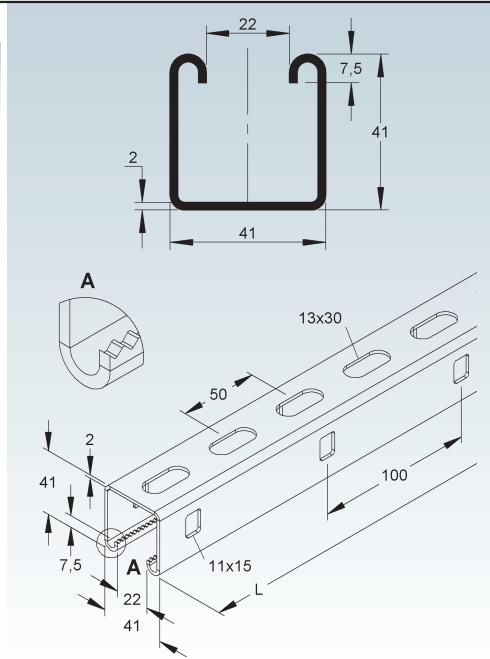

Protective End Cap

Model no.	Color	Weight per 100 pcs kg	Pack/ Box Qty
K03 SKC 88/96	yellow	1,32	20

Suitable for: framing channel 2996Z...

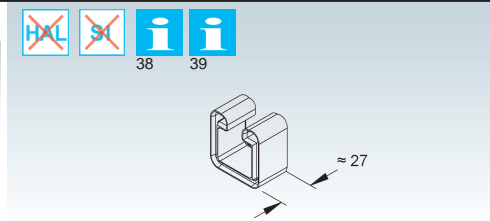

2996ZD Back to back toothed framing channel

perforated, slot width 22 mm

Model no.	Length L	Perforation	Distance between drill holes	Dimension siderail holes	Distance between siderail holes	Weight per 100 m kg	Pack/ Box Qty
	mm Inch	mm	mm Inch	mm	mm Inch		
F 2996ZD/3 FL	3000 118,1	13x30	50 2	11x15	100 3,9	530,95	3

The combination of the toothed channel with the GMZ M... and GMZ F M... channel nuts guarantees higher load ratings.
matching yoke-clamp BUK...

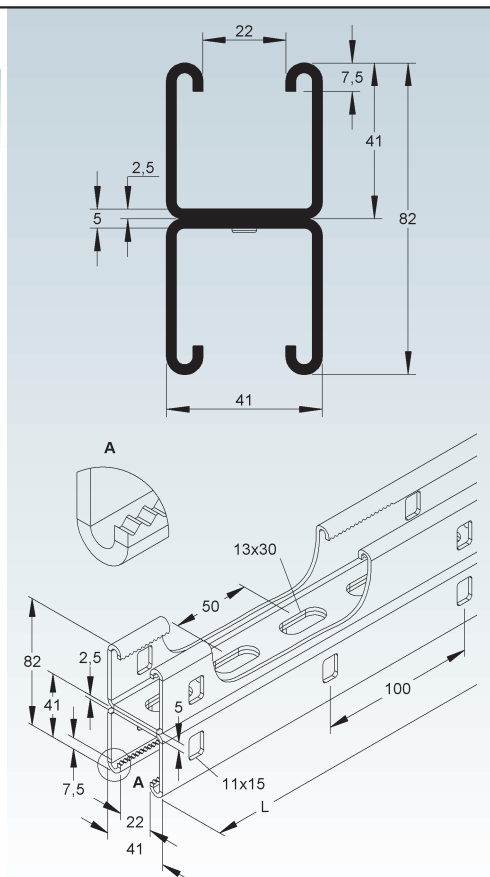

SUPPORT SYSTEM

Protective End Cap

Model no.	Color	Weight per 100 pcs kg	Pack/Box Qty
K03 SKCED 96	black	0,8	50

Suitable for: framing channel 2996Z and 2996ZD

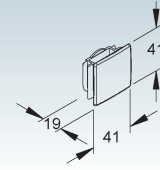

Straight Strut Joiner

Model no.	Thick-ness t mm	Acc. incl.	Weight per 100 pcs kg	Pack/Box Qty
F SSV 4141 F	3	2 FLM 12X25 F	53,64	10

Suitable for: framing channel 2996Z, 2996ZD

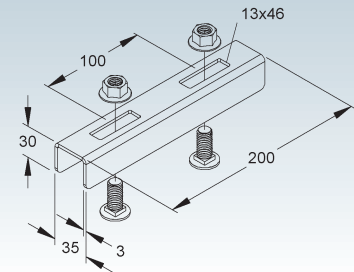

Carriage Bolt with Nut

Model no.	Thread M	Length L mm Inch	Strength category	Weight per 100 pcs kg	Pack/Box Qty
F FLM 12X25 F	12	25 1	8.8	6	20

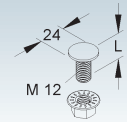

Flanged U-Washer

Model no.	Thick-ness t mm	Weight per 100 pcs kg	Pack/Box Qty
F SGP 41 F	2,5	7,63	20

Suitable for: framing channel 2996Z, 2996ZD, 2997Z

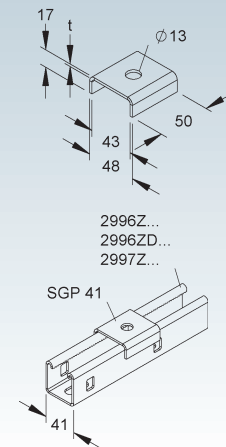

Three Hole Splice Plate

Model no.	Thick-ness t mm	Weight per 100 pcs kg	Pack/Box Qty
F SVL 41 F	4	14,21	10

Suitable for: framing channel 2996Z, 2996ZD, 2997Z

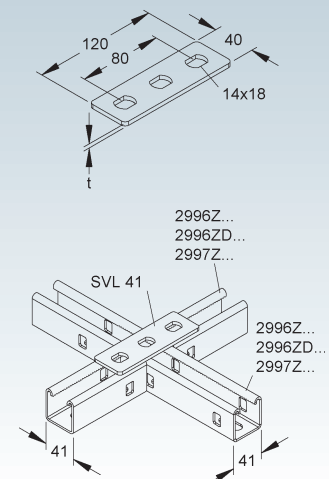

Three Hole Corner Plate

Model no.	Thick-ness t mm	Weight per 100 pcs kg	Pack/Box Qty
F SWS 41 F	5	22,09	10

Suitable for: framing channel 2996Z, 2996ZD, 2997Z

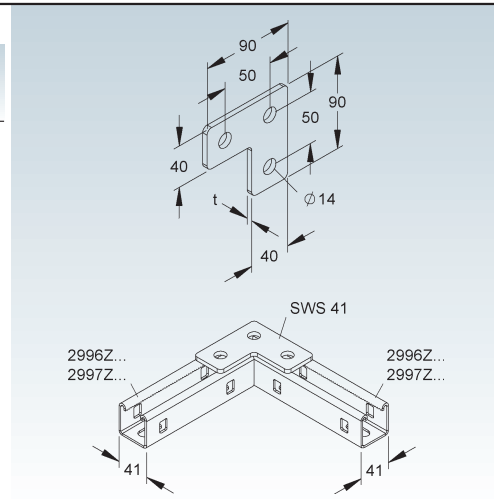

Four Hole Tee Plate

Model no.	Thick-ness t mm	Weight per 100 pcs kg	Pack/Box Qty
F STS 41 F	5	30,06	10

Suitable for: framing channel 2996Z, 2996ZD, 2997Z

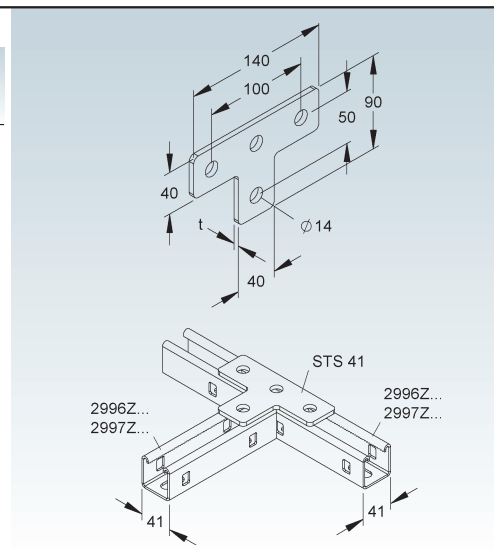

Five Hole U-Support

Model no.	Thick-ness t mm	Weight per 100 pcs kg	Pack/Box Qty
F SBB 41 F	4	24,78	10

Suitable for: connecting framing channel 2996Z to 2996Z, 2996ZD, 2997Z

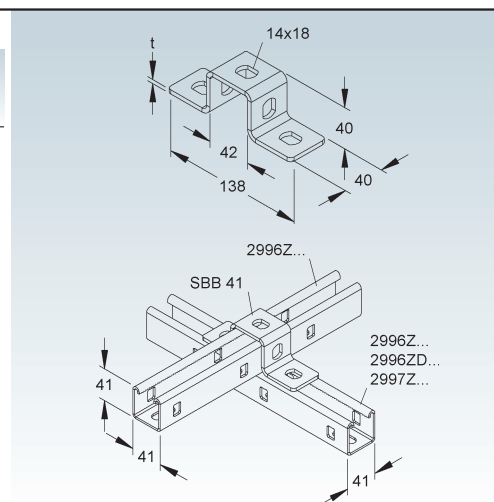

SUPPORT SYSTEM

Channel Nut

	Model no.	Thread M	Strength category	Weight per 100 pcs kg	Pack/Box Qty
F	GMZ M6 F	6	8	3,5	100
F	GMZ M8 F	8	8	3,3	100
F	GMZ M10 F	10	8	3,2	100
F	GMZ M12 F	12	8	3,5	100

Suitable for: framing channel 2986... (18 mm slotwidth), 2996Z... and 2997Z... (22 mm slotwidth)
The GMZ M12 F can only be inserted from the end of the 2986... framing channel.

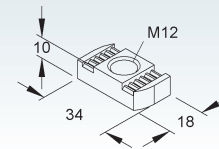
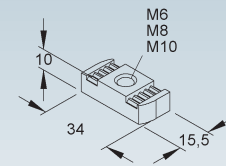

Gripping Channel Nut

	Model no.	Thread M	Strength category	Weight per 100 pcs kg	Pack/Box Qty
F	GMZF M6-22 F	6	8	3,70	100
F	GMZF M8-22 F	8	8	3,57	100
F	GMZF M10-22 F	10	8	3,40	100
F	GMZF M12-22 F	12	8	3,76	100
E5	GMZF M6-22 E5	6	1.4571	3,76	100
E5	GMZF M8-22 E5	8	1.4571	3,62	100
E5	GMZF M10-22 E5	10	1.4571	3,45	100
E5	GMZF M12-22 E5	12	1.4571	3,81	100

Suitable for: framing channel 2996Z... and 2997Z... (22 mm slotwidth)
The GMZF... gripping channel nuts can be positioned exactly and are locking securely into the toothed channel.

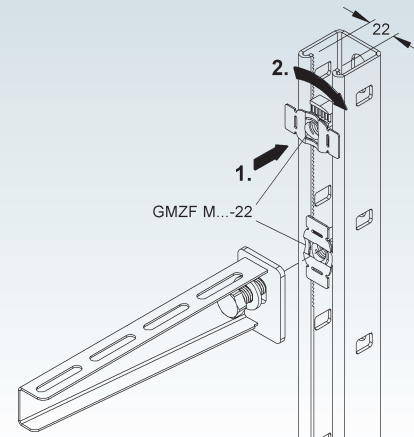
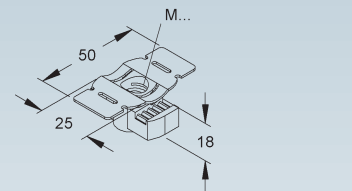

Beam Clamp

	Model no.	Height H	Thickness t	Flange thickness t	Weight per 100 pcs kg	Pack/Box Qty
		mm Inch	mm	mm		
F	HSK 10	10 0,4	7	5 - 9	16,28	50
F	HSK 15	15 0,6	7	10 - 14	17,80	50
F	HSK 20	20 0,8	7	15 - 19	19,31	50
F	HSK 25	25 1	7	20 - 24	20,81	50
F	HSK 30	30 1,2	7	25 - 29	22,33	50
F	HSK 35	35 1,4	7	30 - 34	23,84	50
F	HSK 40	40 1,6	7	35 - 39	25,36	50
E3	HSK 10 E3	10 0,4	6	5 - 9	12,84	10
E3	HSK 15 E3	15 0,6	6	10 - 14	14,02	10
E3	HSK 20 E3	20 0,8	6	15 - 19	15,21	10
E3	HSK 25 E3	25 1	6	20 - 24	16,39	10
E3	HSK 30 E3	30 1,2	6	25 - 29	17,58	10
E3	HSK 35 E3	35 1,4	6	30 - 34	18,76	10
E3	HSK 40 E3	40 1,6	6	35 - 39	19,95	10

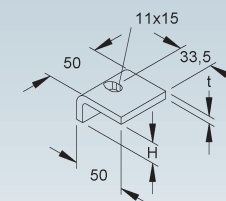

Beam Clamp

heavy-duty version

Model no.	Height H mm Inch	Flange thickness t mm	Weight per 100 pcs kg	Pack/ Box Qty
F HSKS 10	10 0,4	5 - 9	22,17	25
F HSKS 15	15 0,6	10 - 14	24,24	25
F HSKS 20	20 0,8	15 - 19	26,32	25
F HSKS 25	25 1	20 - 24	28,39	25
F HSKS 30	30 1,2	25 - 29	30,46	25
F HSKS 35	35 1,4	30 - 34	32,53	25
F HSKS 40	40 1,6	35 - 39	34,61	25

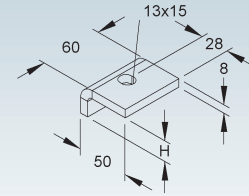

I-Beam Clamping Assembly

Model no.	Flange thickness t mm	Acc. incl.	Weight per 100 pair kg	Pack/ Box Qty
F SPKM 25 F	0 - 14	1 SK 10X50 DIN 931	45,77	10 pair

for attaching headplates or hangers directly to I-beams

M10... tightening torque 46 Nm, 16 mm metric wrench.

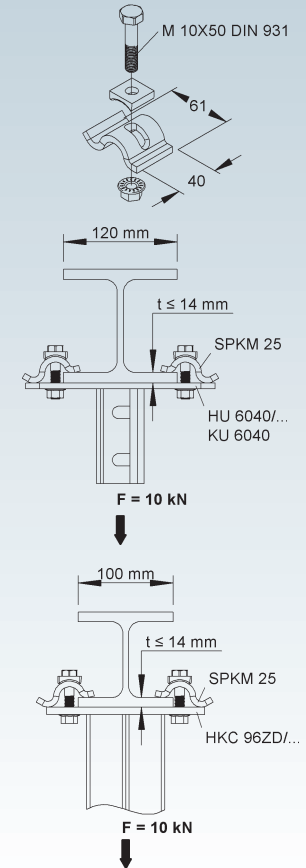

SUPPORT SYSTEM

I-Beam Clamping Assembly

with sliding nut

Model no.	Flange thickness (t) 2986 mm	Flange thickness (t) 2988/2996 mm	Acc. incl.	Weight per 100 pair kg	Pack/Box Qty
F SPKGM 25 F	7 - 11	0 - 10	1 SK 10X50 DIN 931	49,93	10 pair

for attaching C-rails-mounted headplates or hangers to I-beams

M10... tightening torque 46 Nm, 16 mm metric wrench.

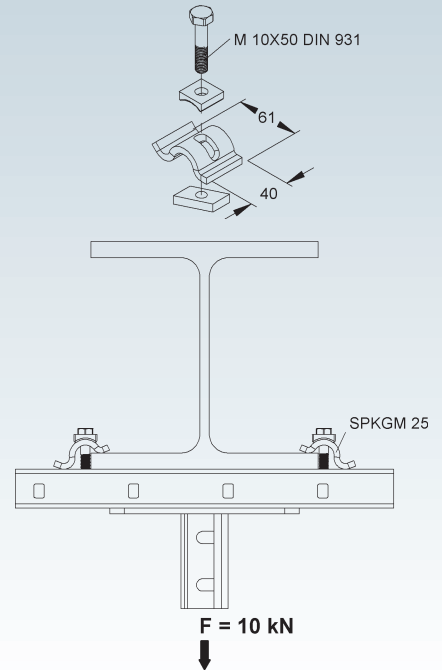

Heavy Duty I-Beam Clamping Assembly

Model no.	Flange thickness t mm	Acc. incl.	Weight per 100 pair kg	Pack/Box Qty
F SPPM 30 F	0 - 25	1 SK 12X75 DIN 931	89,34	10 pair

for attaching headplates or hangers directly to I-beams

M12... tightening torque 84 Nm, 18 mm metric wrench.

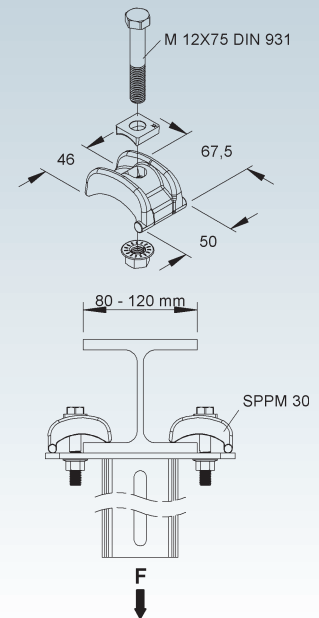
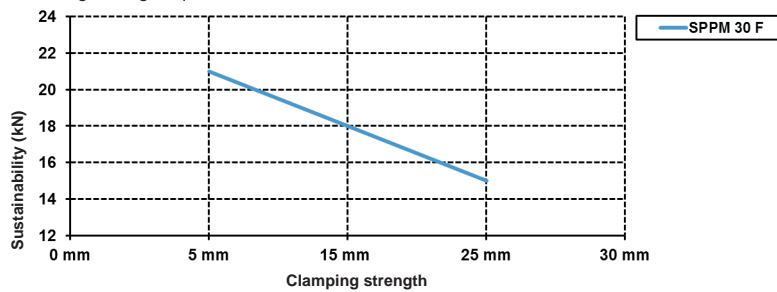

Heavy Duty I-Beam Clamping Assembly

Model no.	Flange thickness t mm	Acc. incl.	Weight per 100 pair kg	Pack/Box Qty
F SPPGM 30 F	0 - 25	1 SK 12X65 DIN 931	91,63	10 pair

for attaching C-rail-mounted headplates or hangers to I-beams
M12... tightening torque 84 Nm, 18 mm metric wrench.

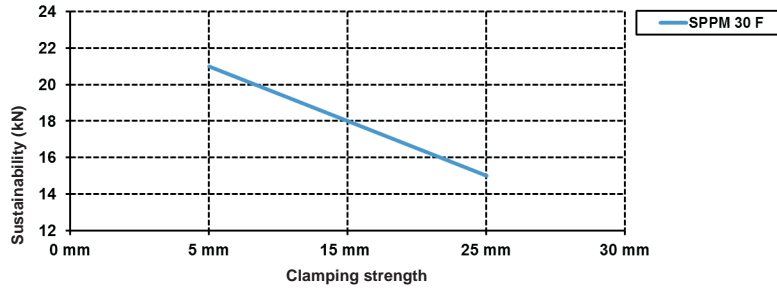

SPPGM 30 F

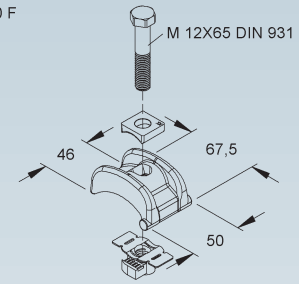

SPPGM 5030 M12 F

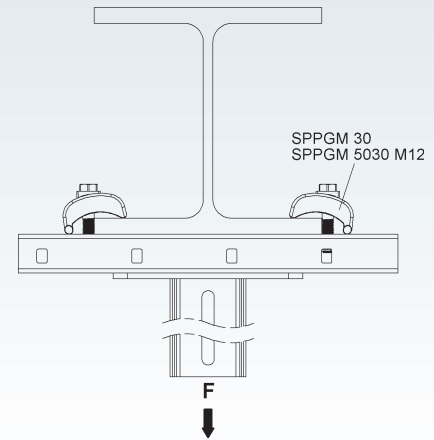
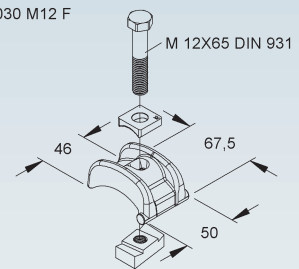

Two Hole Corner Angle

Model no.	Acc. incl.	Weight per 100 pcs kg	Pack/Box Qty
F WWU 150	1 FLM 10X25 F	21,03	50

for floor-, ceiling- or wall-mounting

Suitable for: U-profiles U 4530/..., U 5050/... and U 6040/...

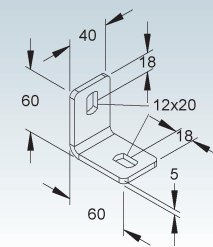

Two Hole Corner Angle

Model no.	Thickness t mm	Acc. incl.	Weight per 100 pcs kg	Pack/Box Qty
F WWU 150/8	5	1 FLM 8X16 F	19,11	50
E3 WWU 150/8 E3	4	1 FLM 8X16 E3	14,87	50

for floor-, ceiling- or wall-mounting

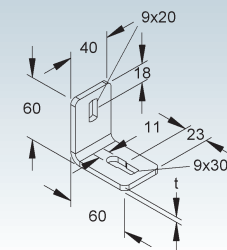

SUPPORT SYSTEM

Three Hole Corner Angle

Model no.	Width B mm Inch	Thick-ness t mm	Acc. incl.	Weight per 100 pcs kg	Pack/Box Qty
F WWA 100	50,0 2	5	1 FLM 10X25 F	24,98	50
E3 WWA 100 E3	48,5 1,9	4	1 FLM 10X25 E3	19,09	50

for floor-, ceiling- or wall-mounting

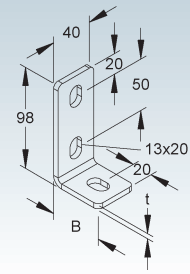

Shelf Bracket

Model no.	Weight per 100 pcs kg	Pack/Box Qty
F TRV 40	41,10	10
E3 TRV 40 E3	38,45	10

for floor-, ceiling- or wall-mounting

Suitable for: profile U 5050/..., U 6040/... and framing channels
Hardware is not included.

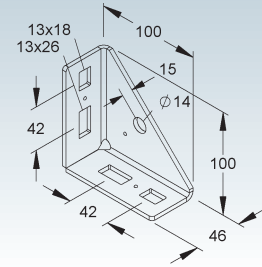

Adjustable Corner Bracket

adjustable from -30° to +30°

Model no.	Acc. incl.	Weight per 100 pcs kg	Pack/Box Qty
F AWG 110/140	2 FLM 10X25 F	58,74	10
E3 AWG 110/140 E3	2 FLM 10X25 E3	54,62	10

for mounting on inclined ceilings

Suitable for: U-profiles and framing channels

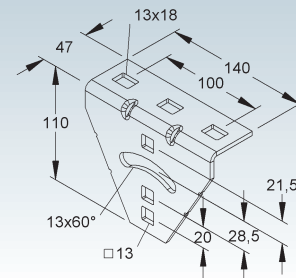

Heavy Duty Square Washer/Anchor Plate

Model no.	Height H mm Inch	Width B mm Inch	Weight per 100 pcs kg	Pack/Box Qty
F VP 50.50	50 2	50 2	10,34	20

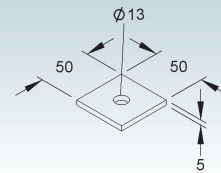

Column Support Bracket

Model no.	Width B mm Inch	Length L mm Inch	Thick- ness t mm	Max. load F at flange distance of I-beam/2 kN	Acc. incl.	Weight per 100 pair kg	Pack/ Box Qty
S TZK 86-96 S	45,5 1,8	100 3,9	2	0,5	4 SK 8X25 V	24,89	10 pair

for clamping channels in between I-beam flanges

Suitable for: framing channel 2986..., 2996Z..., and 2997Z...
The load bearing capacity is valid for up to 400 mm distance in between the legs of the I-beam.
For longer distances the load bearing capacity is smaller.

Please order C-rails separately.

Fastening torque 2,5 Nm

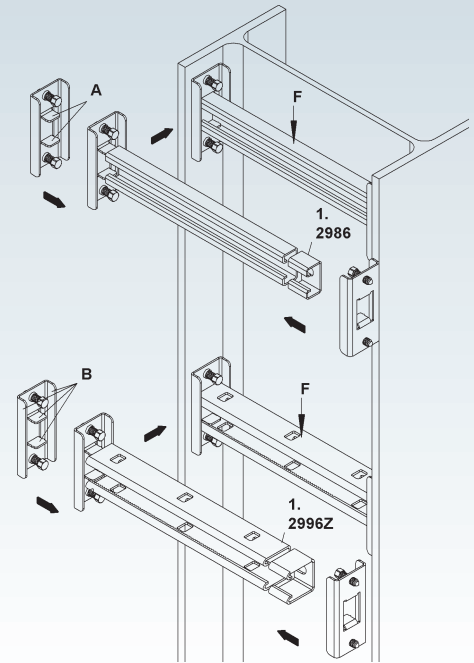
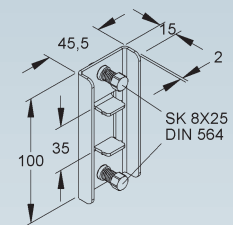

Flange Clamp

Model no.	Thickness of flange (t) mm	Thread M	Vertical nominal load F1 kN	Vertical nominal load F2 kN	Weight per 100 pcs kg	Pack/Box Qty
F PKS M6/10-40 F	6 - 35	6	1,8	1,6	19,31	25
F PKS M8/10-40 F	6 - 35	8	1,8	1,6	21,24	25
E3 PKS M8/10-40 E3	6 - 35	8	1,8	1,6	19,40	25

for angle iron, T- and I- beams with parallel flanges or an inner flange inclination of up to 14%

Fastening torque 4 Nm

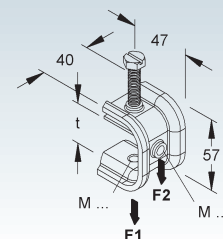

SUPPORT SYSTEM

Beam Clamp with Locknut

Model no.	Flange thickness T	Ø	Thigh width A	Height H	Width B	Max. load F	Weight per 100 pcs	Pack/Box Qty
	mm	mm/M	mm	mm Inch	mm Inch	kN	kg	
F1 FC-7	1 - 19	7	50	45 1,8	42 1,7	2,35	15,6	25
F1 FC-9	1 - 19	9	50	45 1,8	42 1,7	2,35	14,8	25
F1 FC-11	1 - 19	11	50	45 1,8	42 1,7	2,35	14,8	25
F1 FC-13	1 - 23	13	59	54 2,1	49 1,9	3	14,4	25
F1 FC-6T	1 - 19	M6	50	45 1,8	42 1,7	2,35	15,6	25
F1 FC-8T	1 - 19	M8	50	45 1,8	42 1,7	2,35	15,2	25
F1 FC-10T	1 - 19	M10	50	45 1,8	42 1,7	2,35	15,2	25
F1 FC-12T	1 - 23	M12	59	54 2,1	49 1,9	3	22,8	25

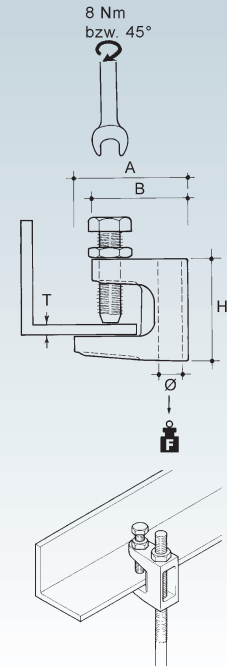

Hammerset Flange Clip

Model no.	Flange thickness T	Distance between drilling holes A	Impact depth	Max. load F	Weight per 100 pcs	Pack/Box Qty
	mm	mm	mm	kN	kg	
F8 AH-38	3 - 8	18	20,3	0,9	1,6	100
F8 AH-814	8 - 14	26	20,3	0,9	1,6	100
F8 AH-1420	14 - 20	30	26,6	0,9	1,8	100

with 6.5 mm hole for chain or wire

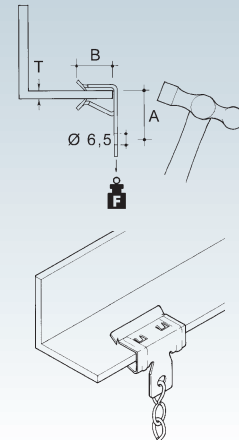

Hammerset Flange Clip

Model no.	Flange thickness T	Mounting distance	Clamping depth	Max. load F	Weight per 100 pcs	Pack/Box Qty
	mm	mm	mm	kN	kg	
F8 EH-38	3 - 8	7,5	33	0,45	2,4	100
F8 EH-814	8 - 14	7,5	33	0,45	2,6	100
F8 EH-1420	14 - 20	7,5	33	0,45	3,1	100

with M6 thread

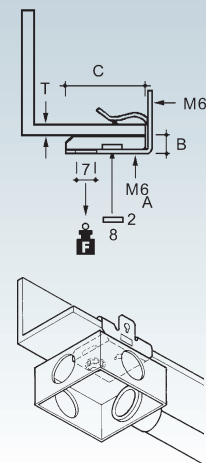

Hammerset Flange Clip

Model no.	Flange thickness T mm	Mounting distance mm	Clamping depth mm	Max. load F kN	Weight per 100 pcs kg	Pack/Box Qty
F8 EH-38S	3 - 8	7,5	33	0,45	2,8	100
F8 EH-814S	8 - 14	7,5	33	0,45	2,9	100
F8 EH-1420S	14 - 20	7,5	33	0,45	3,4	100

with M6X10 stud

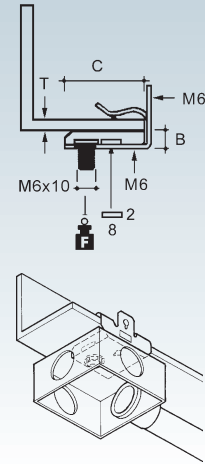

Hex Head Bolt

Model no.	Length L mm Inch	Strength category	Weight per 100 pcs kg	Pack/Box Qty
F SK 6X20 F	20 0,8	8.8	0,58	50
F SK 8X25 F	25 1	8.8	1,39	100
F SK 10X25 F	25 1	8.8	2,55	100
F SK 12X25 F	25 1	8.8	3,41	100

Please maintain proper tightening torque of bolts/nuts especially for all vertical clamping connections.



49

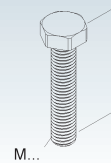

Socket Cap Bolt

with allen wrench drive

Model no.	Thread M	Length L mm Inch	Strength category	Weight per 100 pcs kg	Pack/Box Qty
V M 6X25 912-8.8 V	6	25 1	8.8	0,76	200
V M 6X35 912-8.8 V	6	35 1,4	8.8	0,99	200
V M 8X25 912-8.8 V	8	25 1	8.8	1,50	200
V M 8X35 912-8.8 V	8	35 1,4	8.8	1,89	200
V M 8X50 912-8.8 V	8	50 2	8.8	2,49	200
V M 10X25 912-8.8 V	10	25 1	8.8	2,54	200
V M 10X35 912-8.8 V	10	35 1,4	8.8	3,04	200
V M 10X50 912-8.8 V	10	50 2	8.8	3,93	200

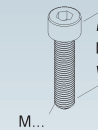

Serrated Flange Nut

Model no.	Thread M	Weight per 100 pcs kg	Pack/Box Qty
V SMF M6 1661 V	6	0,31	200
V SMF M8 1661 V	8	0,71	200
V SMF M10 1661 V	10	1,15	200



Hex Head Bolt

serrated flange nut included

Model no.	Thread M	Length L mm Inch	Strength class bolt / nut	Weight per 100 pcs kg	Pack/Box Qty
V SKM 8X16 V	8	16 0,6	8.8 / 8	1,72	50
V SKM 10X25 V	10	25 1	8.8 / 8	3,60	50
V SKM 10X50 V	10	50 2	8.8 / 8	5,00	50
V SKM 10X70 V	10	70 2,8	8.8 / 8	5,50	50
V SKM 12X50 V	12	50 2	10.9 / 10	7,00	20
V SKM 12X70 V	12	70 2,8	10.9 / 10	8,44	20
E3 SKM 8X16 E3	8	16 0,6	70 / 70	1,72	50
E3 SKM 10X25 E3	10	25 1	70 / 70	3,89	50

Please maintain proper tightening torque of bolts/nuts especially for all vertical clamping connections.



49

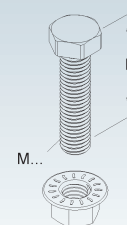

SUPPORT SYSTEM

Carriage Bolt with Nut

serrated flange nut included

	Model no.	Thread M	Length L		Strength category	Weight per 100 pcs kg	Pack/ Box Qty
			mm	Inch			
V	FLM 6X12	6	12	0,5	-	0,79	100
F	FLM 6X12 F	6	12	0,5	-	0,79	50
F	FLM 6X16 F	6	16	0,6	-	0,86	50
F	FLM 8X13 F	8	13	0,5	8.8	2,00	100
F	FLM 8X16 F	8	16	0,6	8.8	2,09	50
F	FLM 8X25 F	8	25	1	8.8	2,34	50
F	FLM 10X25 F	10	25	1	8.8	4,00	50
F	FLM 12X30 F	12	30	1,2	8.8	8,00	50
E3	FLM 6X12 E3	6	12	0,5	1.4301	0,82	50
E3	FLM 8X16 E3	8	16	0,6	1.4301	1,98	50
E3	FLM 10X25 E3	10	25	1	1.4301	3,66	50

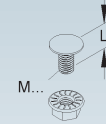

Carriage Bolt with Shaft and Nut

serrated flange nut and washer included

	Model no.	Thread M	Length L		Weight per 100 pcs kg	Pack/ Box Qty
			mm	Inch		
V	FLDM 6X30	6	30	1,2	1,25	50
V	FLDM 6X45	6	45	1,8	1,56	50
V	FLDM 6X60 V	6	60	2,4	2,08	50
E3	FLDM 6X45 E3	6	45	1,8	1,56	50

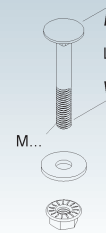

Threaded Rod, size M6

	Model no.	Length L		Strength category	Acc. incl.	Weight per 100 pcs kg	Pack/ Box Qty
		mm	Inch				
V	M 6/1000	1000	39,4	4.8	4 SMU 6	21,72	25

Nuts and washers are included.



Threaded Rod, size M8

	Model no.	Length L		Strength category	Acc. incl.	Weight per 100 pcs kg	Pack/ Box Qty
		mm	Inch				
V	M 8/1000	1000	39,4	4.8	4 SMU 8	35,1	25

Nuts and washers are included.

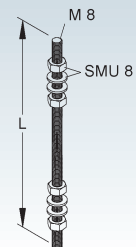

Threaded Rod, size M10

Model no.	Length L	Strength category	Acc. incl.	Weight per 100 pcs kg	Pack/ Box Qty
	mm Inch				
V M 10/1000	1000 39,4	4.8	4 SMU 10	56,1	25

Nuts and washers are included.

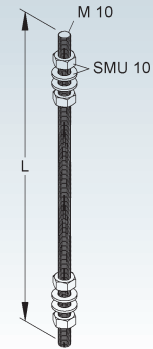
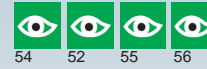

Threaded Rod, size M12

Model no.	Length L	Strength category	Acc. incl.	Weight per 100 pcs kg	Pack/ Box Qty
	mm Inch				
V M 12/1000	1000 39,4	4.8	4 SMU 12	81,87	20

Nuts and washers are included.

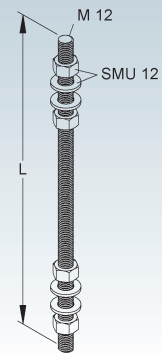

Large Diameter Washer

Model no.	Inner diameter	Thick- ness t	Weight per 100 pcs kg	Pack/ Box Qty	
	mm Inch				mm
V UGM 6	6,4 0,3	18	1,6	0,26	100
V UGM 8	8,4 0,3	24	2,0	0,68	100
V UGM 10	10,5 0,4	30	2,5	1,22	100
V UGM 12 V	13,0 0,5	37	3,0	2,22	100
F UGM 6 F	6,4 0,3	18	1,6	0,28	100
F UGM 8 F	8,4 0,3	24	2,0	0,74	100
F UGM 10 F	10,5 0,4	30	2,5	1,34	100
F UGM 12 F	13,0 0,5	37	3,0	2,44	100
E3 UGM 6 E3	6,4 0,3	18	1,6	0,26	100
E3 UGM 8 E3	8,4 0,3	24	2,0	0,68	100
E3 UGM 10 E3	10,5 0,4	30	2,5	1,22	100
E3 UGM 12 E3	13,0 0,5	37	3,0	2,23	100

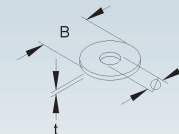

Washer according to DIN EN ISO 7089 standard

Model no.	Inner diameter	Thick- ness t	Weight per 100 pcs kg	Pack/ Box Qty	
	mm Inch				mm
F US M6 F	6,4 0,3	12,5	1,6	0,11	500
F US M8 F	8,4 0,3	17,0	1,6	0,20	500
F US M10 F	10,5 0,4	21,0	2,0	0,39	500
F US M12 F	13,0 0,5	24,0	2,5	0,69	100

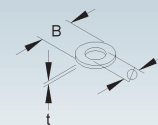

SUPPORT SYSTEM

Hexagonal Nut

washer included

	Model no.	Thread M	Weight per 100 pcs kg	Pack/Box Qty
V	SMU 8	8	0,77	50
V	SMU 10	10	1,53	50
V	SMU 12	12	2,32	40
E3	SMU 10 E3	10	1,53	50
E3	SMU 12 E3	12	2,25	40



Hexagonal Rod Coupling

	Model no.	Thread M	Length L mm Inch	Weight per 100 pcs kg	Pack/Box Qty
V	VBSM 8	8	40 1,6	1,95	50
V	VBSM 10	10	40 1,6	2,30	50
V	VBSM 12	12	40 1,6	4,40	50

for coupling threaded rods

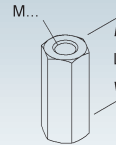

Serrated Washer

	Model no.	Inner diameter mm Inch	Weight per 100 pcs kg	Pack/Box Qty
V	ZS M6	6,4 0,3	0,02	100
V	ZS M8	8,4 0,3	0,05	100
V	ZS M10	10,5 0,4	0,08	100
V	ZS M12	12,5 0,5	0,11	100

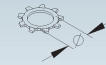

Expansion Anchor

Approval No.: ETA-18/0541, with flange nut and metric connecting thread M6

	Model no.	Connection thread metric	Length L mm Inch	Diameter drillhole mm	Clamping range t fix mm	Effective anchoring depth h ef mm	Weight per 100 pcs kg	Pack/Box Qty
V	DAM 6X5	6	50 2	6	≤ 5	30	1,38	50
V	DAM 6X10	6	55 2,2	6	≤ 10	30	1,30	50

Please always follow the enclosed installation instructions and contact Niedax for detailed technical specifications.

Recommended Torque 4 Nm

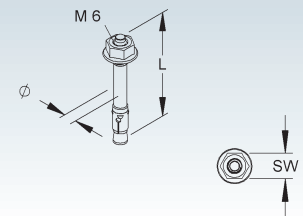

Expansion Anchor

Approval No.: ETA-18/0542, with nut and large washer

	Model no.	Connection thread metric	Length L mm Inch	Diameter drillhole mm	Washer diameter mm	Clamping range t fix mm	Effective anchoring depth h ef mm	Weight per 100 pcs kg	Pack/Box Qty
V	DAZ 8X10	8	75 3	8	24	≤ 10	45	3,16	50
V	DAZ 10X10	10	95 3,7	10	25	≤ 10	60	6,33	50
V	DAZ 12X10	12	110 4,3	12	30	≤ 10	70	10,27	20

Please always follow the enclosed installation instructions and contact Niedax for detailed technical specifications.

Recommended Torque:

DAZ 8X10 - tightening torque 20 Nm

DAZ 10X10 - tightening torque 45 Nm

DAZ 12X10 - tightening torque 60 Nm

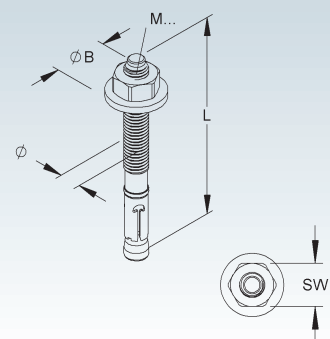

Expansion Anchor

Approval No.: ETA-18/0542, with nut and washer

	Model no.	Connection thread metric	Length L		Diameter drillhole mm	Washer diameter mm	Clamping range t fix mm	Effective anchoring depth h ef mm	Weight per 100 pcs kg	Pack/Box Qty
			mm	Inch						
V	DAZ 10X30	10	115	4,5	10	20	≤ 30	60	7,32	25
V	DAZ 16X25	16	148	5,8	16	30	≤ 25	85	23,78	10

Please always follow the enclosed installation instructions and contact Niedax for detailed technical specifications.

Recommended Torque:
 DAZ 10X30 - tightening torque 45 Nm
 DAZ 16X25 - tightening torque 110 Nm



47

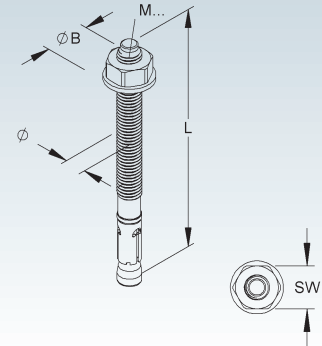

Concrete Screw Anchor

Approval No.: ETA 15/0784, Torx T30 large diameter pan-head

	Model no.	Diameter (Ø) mm	Length L		Drive size	Diameter drillhole mm	Max. mounting thickness mm	Weight per 100 pcs kg	Pack/Box Qty
			mm	Inch					
V	NSA 7.5X50/FGK-T30 V	7,5	50	2	T30	6	15	1,62	100

for indoor use only

Suitable for: mounting e.g. framing channel
 Recommended screw tightening torque 20 Nm



48

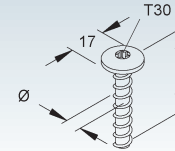

Edge Protection Strip

with steel inserts

	Model no.	Color	Clamping range mm	Weight per 100 m kg	Pack/Box Qty
K10	RKBA 6	black	1-2	7,7	10 m
K10	RKBA 10	black	0,75-4	15,0	10 m



RKBA 5

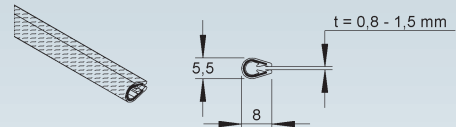

RKBA 6

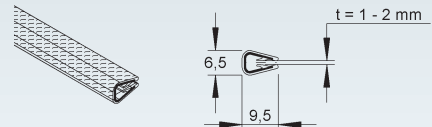

RKBA 10

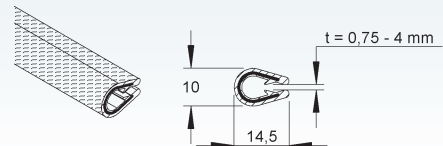

SUPPORT SYSTEM

Edge Protection Ring

UV resistant

Model no.	Color	Inside height H		Inside dimension B		Weight per 100 pcs kg	Pack/Box Qty	
		mm	Inch	mm	Inch			
K04	KSR 20 A	black	14,5	0,6	58	2,3	0,32	20
K04	KSR 30 A	black	24,0	0,9	58	2,3	0,38	20

to protect cables at the knockouts

Suitable for: distribution cable trays RSV 50... and RLCI 60...

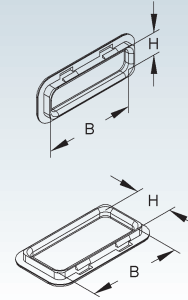

Edge Protection Ring

UV resistant

Model no.	Color	Inside height H		Inside dimension B		Weight per 100 pcs kg	Pack/Box Qty	
		mm	Inch	mm	Inch			
K04	KSR 40 A	black	34,5	1,4	144,5	5,7	0,97	20

to protect cables at the knockouts

Suitable for: distribution cable trays RLCPV 85... and RSV 110...

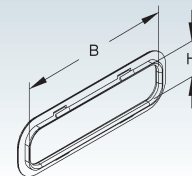

Punch and Die Set for Hydraulic Tools

Model no.	Height H	Width B		Weight per 100 pcs kg	Pack/Box Qty		
		mm	Inch				
B	W-BL 20.65	20	0,8	65	2,6	108	1
B	W-BL 30.65	30	1,2	65	2,6	108	1

for punching square knockouts in mild steel of max. 2 mm thickness

Please install KSR...A edge protection rings to protect cables from damage.

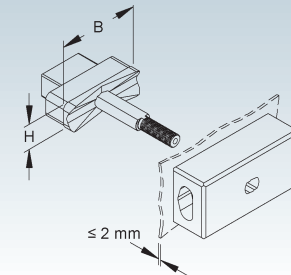

Yoke-Clamp

with plastic pressure cradle

Model no.	For cable dia. mm	Bolt head	Thread M	Weight per 100 pcs kg	Pack/ Box Qty
F BK 14	8 - 14	slotted hex head	6	3,42	100
F BK 18	12 - 18	slotted hex head	6	3,65	100
F BK 22	16 - 22	slotted hex head	6	3,92	100
F BK 30	22 - 30	slotted hex head	6	4,67	100
F BK 34	28 - 34	slotted hex head	6	5,05	100
F BK 42	34 - 42	slotted hex head	6	8,02	100
F BK 46	40 - 46	slotted hex head	8	9,30	100
F BK 54	46 - 54	slotted hex head	8	10,99	50
F BK 58	52 - 58	slotted hex head	8	11,61	50
F BK 64	58 - 64	slotted hex head	8	12,55	50

for one cable

Suitable for: slot width 16-17 mm

Please order GWU... counter pressure cradles separately.

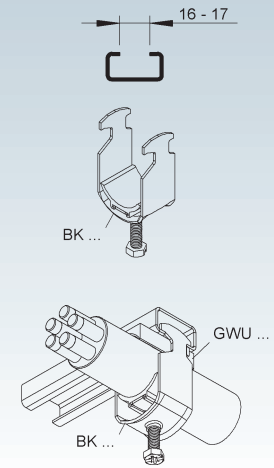

Yoke-Clamp

with plastic pressure cradle

Model no.	For cable dia. mm	Bolt head	Thread M	Weight per 100 pcs kg	Pack/ Box Qty
F BUK 14	8 - 14	slotted hex head	6	3,55	100
F BUK 18	12 - 18	slotted hex head	6	3,77	100
F BUK 22	16 - 22	slotted hex head	6	4,10	100
F BUK 30	22 - 30	slotted hex head	6	4,94	100
F BUK 34	28 - 34	slotted hex head	6	5,17	100
F BUK 42	34 - 42	slotted hex head	6	7,98	100
F BUK 46	40 - 46	slotted hex head	8	9,30	100
F BUK 54	46 - 54	slotted hex head	8	10,79	50
F BUK 58	52 - 58	slotted hex head	8	11,34	50
F BUK 64	58 - 64	slotted hex head	8	11,80	50

for one cable

Suitable for: slot width 18-22 mm

Please order GWU... counter pressure cradles separately.

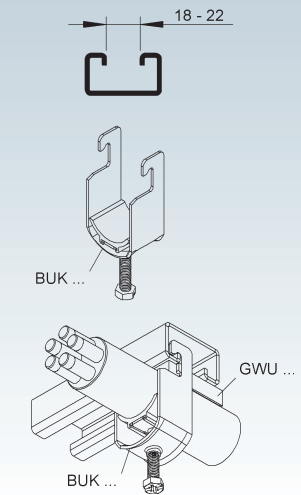

Yoke Clamp for Angle Sections

with plastic pressure cradle

Model no.	For cable dia. mm	Bolt head	Thread M	Weight per 100 pcs kg	Pack/ Box Qty
F BWK 14	8 - 14	slotted hex head	6	4,68	100
F BWK 18	12 - 18	slotted hex head	6	4,93	100
F BWK 22	16 - 22	slotted hex head	6	5,21	100
F BWK 30	22 - 30	slotted hex head	6	5,90	100
F BWK 34	28 - 34	slotted hex head	6	6,26	100
F BWK 42	34 - 42	slotted hex head	6	9,22	100
F BWK 46	40 - 46	slotted hex head	8	10,61	100
F BWK 54	46 - 54	slotted hex head	8	11,59	50
F BWK 58	52 - 58	slotted hex head	8	12,09	50
F BWK 64	58 - 64	slotted hex head	8	12,96	50

for one cable

Please order GWU... counter pressure cradles separately.

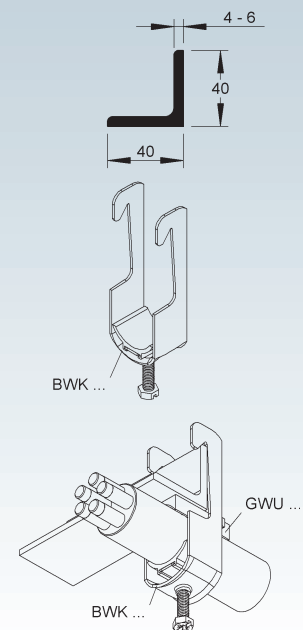

SUPPORT SYSTEM

Counter Pressure Cradle for all Yoke-Clamps

Model no.	Similar to RAL	For cable dia. mm	Length L mm Inch	Weight per 100 pcs kg	Pack/ Box Qty
K02 GWU 12	7035	6 - 12	40 1,6	0,08	100
K02 GWU 14	7035	10 - 14	40 1,6	0,10	100
K02 GWU 18	7035	14 - 18	40 1,6	0,13	100
K02 GWU 22	7035	18 - 22	40 1,6	0,23	100
K02 GWU 30	7035	26 - 30	40 1,6	0,37	100
K02 GWU 34	7035	30 - 34	40 1,6	0,42	100
K02 GWU 42	7035	38 - 42	40 1,6	0,66	50
K02 GWU 46	7035	42 - 46	40 1,6	0,73	50
K02 GWU 54	7035	50 - 54	45 1,8	1,27	50
K02 GWU 58	7035	54 - 58	45 1,8	1,42	50
K02 GWU 64	7035	58 - 64	45 1,8	1,53	50

for insertion into the clamp bracket

Suitable for: yoke-clamp BK..., BUK... and BWK...

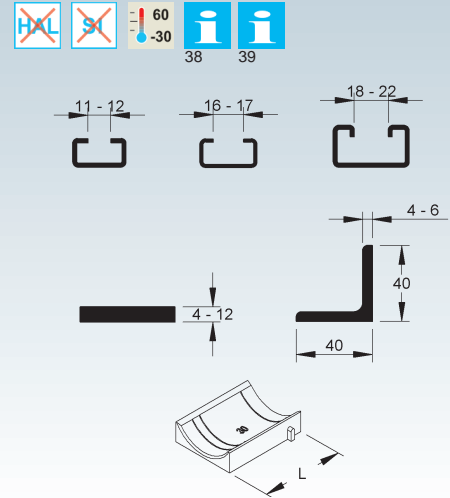

NOTES

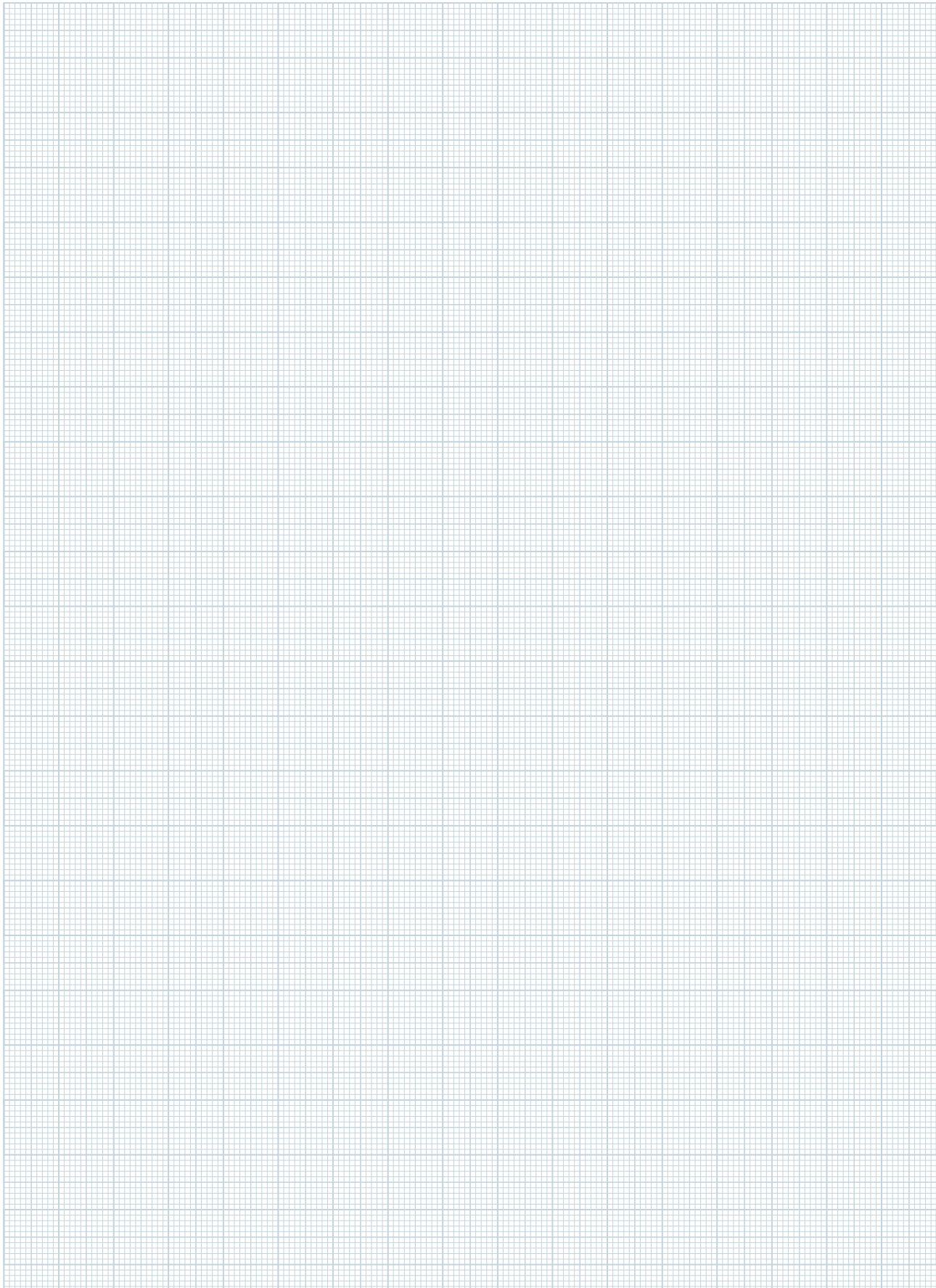

NXCITOLine

ONE CLICK - FINISHED!

Easy Handling:

NX CITO wire mesh tray can be installed smoothly and quickly even in confined spaces.

No need for bolts and splices:

NX CITO wire mesh trays are connected with a patented snap lock mechanism that ensures the same load rating as bolted splices.

NX CITO Wire Mesh Tray is fully compatible with all existing accessories.

Grounding lugs, mounting plates for junction boxes ...

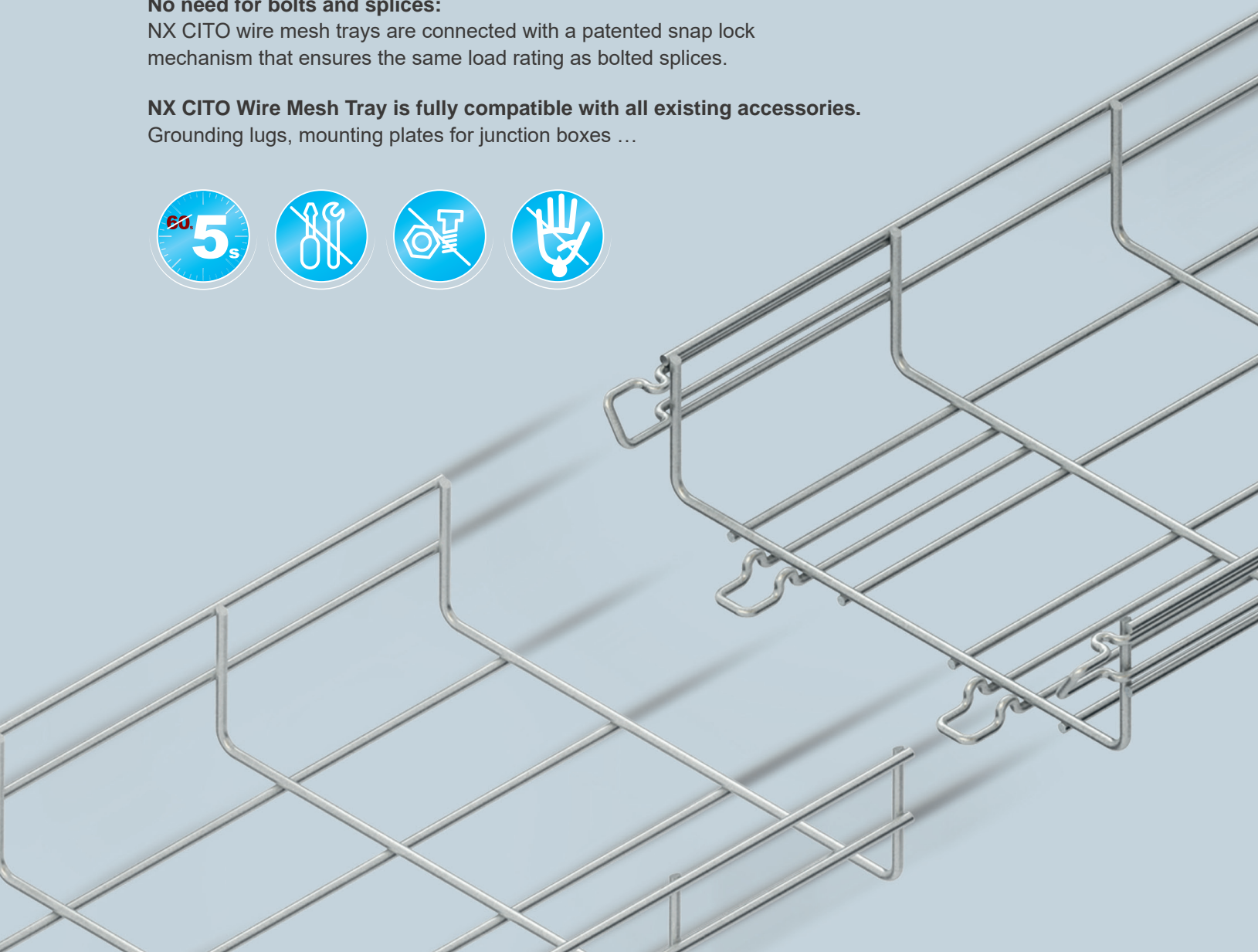



WIRE MESH TRAY SYSTEM

- Wire Mesh Tray
- Dividers
- Fittings
- Covers
- Accessories

Wire Mesh Tray is lightweight, flexible and easy to install. Due to its small surface area there is no accumulation of dirt or humidity. Cable ventilation is perfect. There is no need for long term advanced planning and ordering. Just get straight sections of tray, a few accessories like the universal splice kit and a bolt cutter and you are ready to go. All kinds of fittings can be done onsite easily.

Wire Mesh Tray is available in many finishes and can be used in industrial and commercial environments, inside and outside.

All straight sections of cable tray as well as their corresponding system components (fittings, splice plates, covers, ...) are classified by UL in accordance with NEMA VE 1 for the USA and CSA C22.1 No. 126.1 for Canada.

An 'X' in the part number will be added for labeling according to UL instructions (see catalog page 40).



WIRE MESH TRAY SYSTEM

Available Side Rail Heights

Height	Nominal	Height	Nominal
54	2	105	4
mm	inches	mm	inches

SYSTEM	Cito Line Wire Mesh Tray	MTC 54...	Page 156
	Flexible Horizontal and Vertical Elbow	MTCE 54...	Page 156
	Cito Line Wire Mesh Tray	MTC 105...	Page 157
ACCESSORIES	Flexible Horizontal and Vertical Elbow	MTCE 105...	Page 157
	Peaked Cover for MTC Wire Mesh Tray	MTCC...	Page 158
	Retaining Bracket	GRDHL 30 S	Page 158
	Universal Splice Bolt for Wire Mesh Tray	GRHKM 6X15 V	Page 159
	Bendable Multifunction Splice Bar	GTVL 300 V	Page 159
	Square Splice Washer	GTL 20 V	Page 159
	U-Shaped Square Washer	GTL 30 V	Page 159
	Large Square Splice Washer/Clamping Bracket	GTL 40 V	Page 159
	Mushroom Head Bolt	FLM 6X20 G	Page 159
	J-Hook Bolt	GRSM 6 V	Page 159
	Divider	RW...	Page 160
	Splice Plate for Divider	RTV...	Page 160
	Mounting Clamp for Divider	GRTB 6 S	Page 160
	Mounting Clip for Divider	MTCDC 24 E2	Page 161
	Cable Drop Out	GTKA 50 S	Page 161
	Wall and Box Mount Bracket for Wire Mesh Tray	GTMB 65 S	Page 161
	Trapeze Hanger for Wire Mesh Tray	GTAB 8 S	Page 162
	Attachment Clip for MTC Wire Mesh Tray	GTWAB 50 S	Page 162
	Wire Mesh Mounting Clamp	GRKHV 173 S	Page 163
	Bracket	KTAC...	Page 163
	C-Bracket for Wire Mesh Tray	ZC...	Page 164
	Hold Down Clip for Wire Mesh Tray	MTCSC 22 E2	Page 164
	Universal Attachment Bracket	MTCUP 100 S	Page 165

Please find the nominal dimensions of accessories in the chart section.

MTC ^{NX}CITOLine Wire Mesh Tray - fast and easy installed.

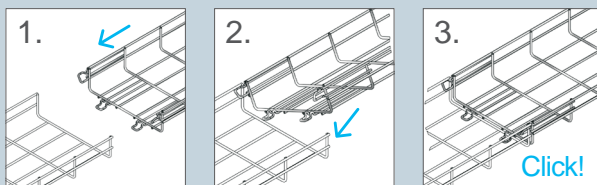

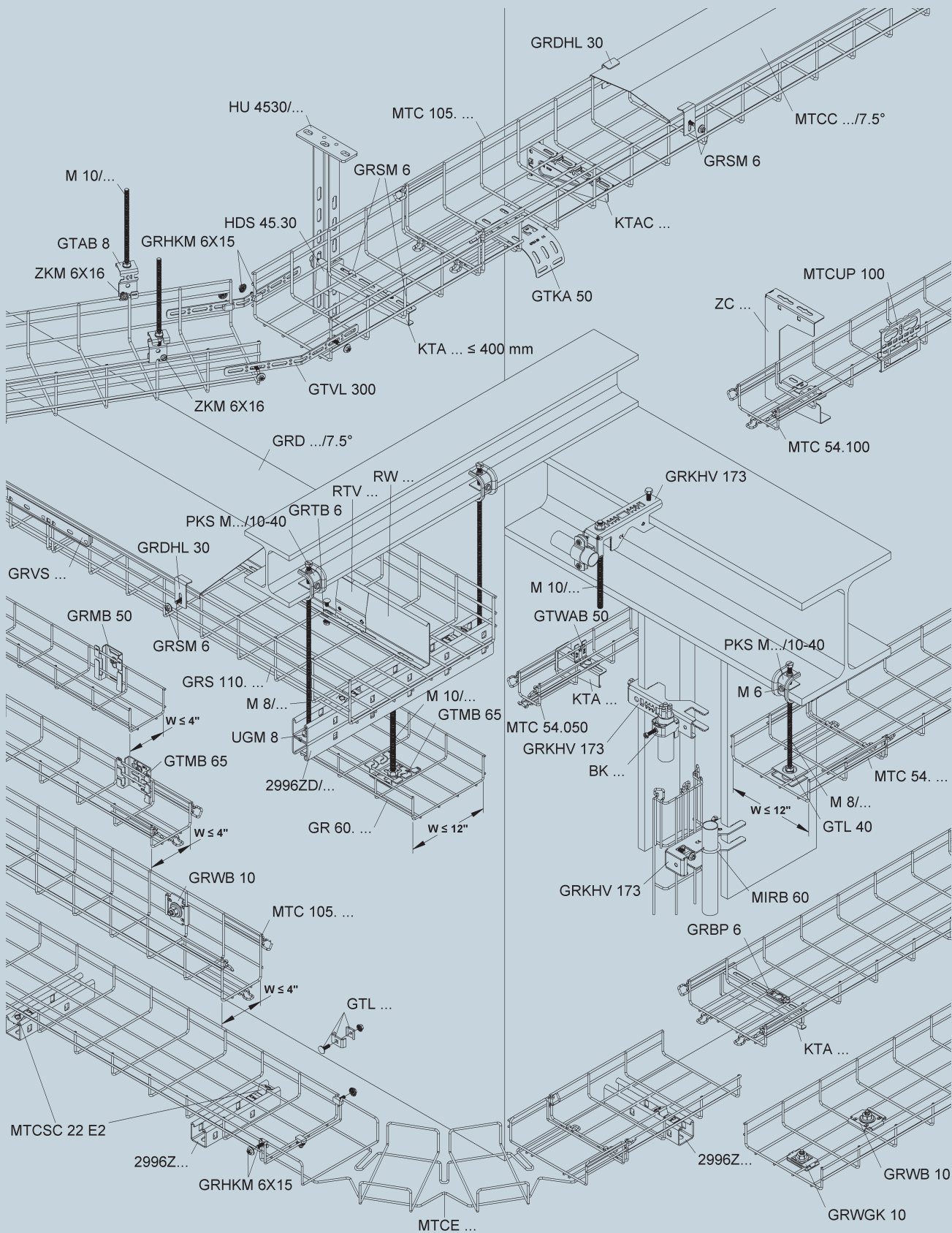

WIRE MESH TRAY SYSTEM

Wire Mesh Cable Tray Specifications:

A. CABLE TRAY DESIGN

1. Wire mesh cable tray shall utilize high mechanical strength steel wire that is welded into a 2" x 4" (50 mm x 100 mm) grid system. This grid is then formed into channels, which support and carry cables and permit ventilation of cables and maximum heat dissipation.

B. MATERIAL

1. **Electro-plated zinc galvanized: ASTM B633.**
To be applied to welded and formed wire mesh surfaces.
2. **Hot dipped galvanized steel.**
All trays to be hot-dipped galvanized after fabrication in accordance with ASTM A123.
3. **Stainless steel.**
All trays are to be constructed of AISI type 304 or type 316 stainless steel for maximum corrosion resistance
4. **Epoxy Powder Coated Paint:**
available on special request

C. TRAY SIZE

1. **Height:** Trays shall have an overall height of 2/2.3", 4/4.3" (54/60 and 105/110 mm).
2. **Width:** Widths shall be 2", 4", 6", 8", 12", 16", 18" 20" and 24" (50/60, 100, 150, 200, 300, 400, 450, 500 and 600 mm).
3. **Length:** Length shall be a nominal 10' or 3 meters.

D. FITTINGS:

1. Shall be fabricated in the field by cutting wires with offset blade bolt cutters. Cuts shall be made in a manner reducing sharp edges and projections so they do not harm cables or installation personnel.
2. **Dividers.** Provide pre-galvanized steel, full depth divider strips to follow the contours of the mesh sections to allow different wiring systems to be run in the same tray.
3. **Supports.** Manufacturers specified supports and hardware are to be used for installation
4. **Splices.** Two options available, bolted type or non bolted to splice sections end to end, in pre-galvanized steel, hot dipped galvanized steel, and stainless steel.

E. UL CLASSIFICATION

1. Straight sections shall be UL classified as an equipment grounding conductor

F. DESIGN AND MANUFACTURE

1. GRX/GRSX series cable tray shall be manufactured by The Niedax Group.
2. MTCX series cable tray shall be manufactured by The Niedax Group.



Load/Span Class Designation in accordance with NEMA VE 1 and CSA C22.2 No. 126.1

Niedax Series	Minimum Area		Load class in accordance to NEMA VE 1		
	(calculational) mm ² / in. ²	in accordance to NEMA VE 2 mm ² / in. ²	Rated Load Kg/m / lb./ft.	Support spacing m / ft.	Load/Span Class
MTCX 54.050 V	60 / 0.09	-	37 / 25	1.5 / 5	5AA
MTCX 54.100 V	72 / 0.11	-	37 / 25	1.5 / 5	5AA
MTCX 54.150 V	84 / 0.13	-	37 / 25	1.5 / 5	5AA
MTCX 54.200 V	96 / 0.15	-	37 / 25	1.5 / 5	5AA
MTCX 54.300 V	181 / 0.28	129 / 0.2	37 / 25	2.4 / 8	8AA
MTCX 54.400 V	217 / 0.34	129 / 0.2	37 / 25	2.4 / 8	8AA
MTCX 54.450 V	235 / 0.36	129 / 0.2	37 / 25	2.4 / 8	8AA
MTCX 54.500 V	253 / 0.39	129 / 0.2	37 / 25	2.4 / 8	8AA
MTCX 54.600 V	290 / 0.45	258 / 0.4	37 / 25	2.4 / 8	8AA
MTCX 105.100 V	96 / 0.15	129 / 0.2	37 / 25	1.5 / 5	5AA
MTCX 105.150 V	108 / 0.17	129 / 0.2	37 / 25	1.5 / 5	5AA
MTCX 105.200 V	181 / 0.28	129 / 0.2	37 / 25	2.4 / 8	8AA
MTCX 105.300 V	217 / 0.34	129 / 0.2	74 / 50	2.4 / 8	8A
MTCX 105.400 V	253 / 0.39	129 / 0.2	74 / 50	2.4 / 8	8A
MTCX 105.450 V	271 / 0.42	258 / 0.4	74 / 50	2.4 / 8	8A
MTCX 105.500 V	290 / 0.45	258 / 0.4	74 / 50	2.4 / 8	8A
MTCX 105.600 V	326 / 0.5	258 / 0.4	74 / 50	2.4 / 8	8A

WIRE MESH TRAY SYSTEM

Cito Line Wire Mesh Tray

with integrated snap lock mechanism

Model no.	Inside width B mm Inch	Steel wire-Ø lengthwise mm	Steel wire-Ø crosswise mm	Weight per 100 m kg	Pack/ Box Qty
✓ MTC 54.050 V	50 2	3,90	3,90	62,98	2 x 3 m
✓ MTC 54.100 V	100 3,9	3,90	3,90	76,66	2 x 3 m
✓ MTC 54.150 V	150 5,9	3,90	3,90	89,91	2 x 3 m
✓ MTC 54.200 V	200 7,9	3,90	3,90	104,16	2 x 3 m
✓ MTC 54.300 V	300 11,8	4,82	4,82	202,94	2 x 3 m
✓ MTC 54.400 V	400 15,7	4,82	5,82	283,58	2 x 3 m
✓ MTC 54.450 V	450 17,7	4,82	5,82	313,33	2 x 3 m
✓ MTC 54.500 V	500 19,7	4,82	5,82	333,23	2 x 3 m
✓ MTC 54.600 V	600 23,6	4,82	5,82	382,80	2 x 3 m

MTC wire mesh tray can be special ordered in AISI 304 (E3) and AISI 316L (E4) stainless steel. Certain restrictions apply!

Load Chart: q = uniformly distributed load (tested according to DIN EN IEC 61537 standard)

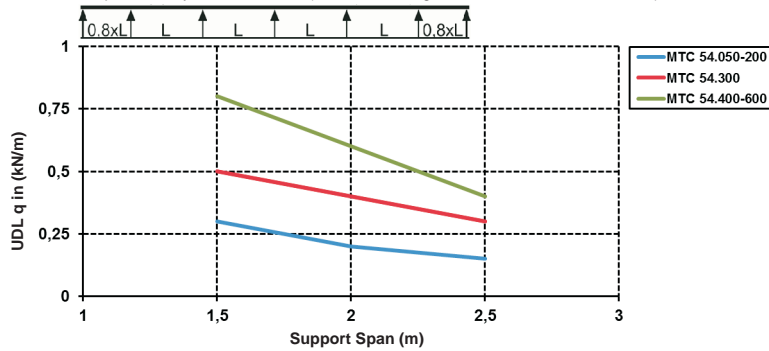

Specified load ratings are independent of splice plate location.

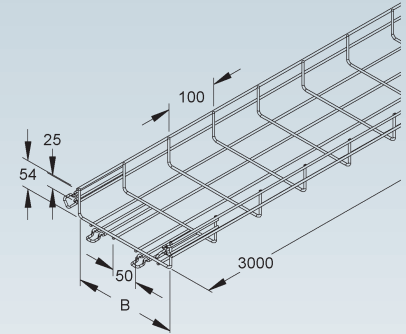

Flexible Horizontal and Vertical Elbow

with integrated splice connector

Model no.	Inside width B mm Inch	Weight per 100 pcs kg	Pack/ Box Qty
✓ MTCE 54.100 V	100 3,9	30,55	1
✓ MTCE 54.150 V	150 5,9	34,76	1
✓ MTCE 54.200 V	200 7,9	54,45	1
✓ MTCE 54.300 V	300 11,8	106,80	1

Suitable for: wire mesh tray MTC 54...

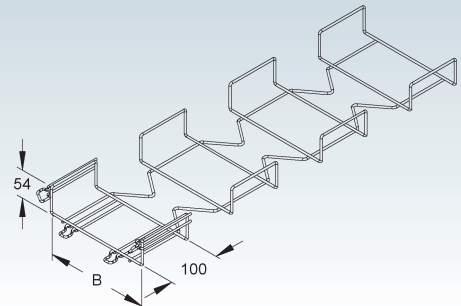
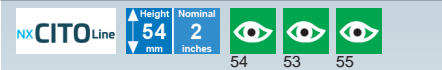

Cito Line Wire Mesh Tray

with integrated snap lock mechanism

Model no.	Inside width B mm Inch	Steel wire-Ø lengthwise mm	Steel wire-Ø crosswise mm	Weight per 100 m kg	Pack/ Box Qty
✓ MTC 105.100 V	100 3,9	3,90	3,90	104,37	2 x 3 m
✓ MTC 105.150 V	150 5,9	3,90	3,90	117,61	2 x 3 m
✓ MTC 105.200 V	200 7,9	4,82	4,82	203,45	2 x 3 m
✓ MTC 105.300 V	300 11,8	4,82	5,82	280,79	2 x 3 m
✓ MTC 105.400 V	400 15,7	4,82	5,82	325,95	2 x 3 m
✓ MTC 105.450 V	450 17,7	4,82	5,82	363,33	2 x 3 m
✓ MTC 105.500 V	500 19,7	4,82	5,82	373,30	2 x 3 m
✓ MTC 105.600 V	600 23,6	4,82	5,82	421,64	2 x 3 m

MTC wire mesh tray can be special ordered in AISI 304 (E3) and AISI 316L (E4) stainless steel. Certain restrictions apply!

Load Chart: q = uniformly distributed load (tested according to DIN EN IEC 61537 standard)

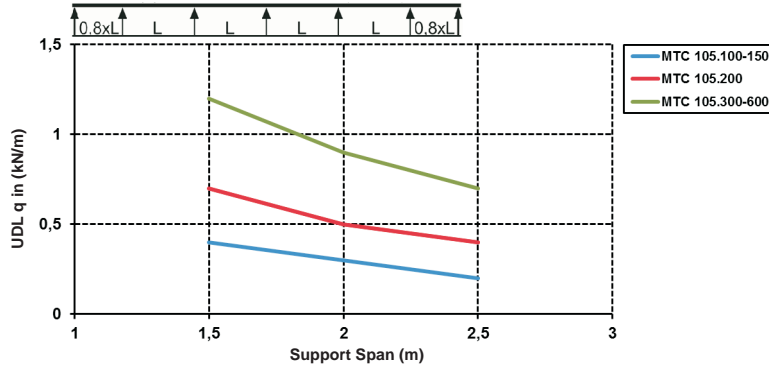

Specified load ratings are independent of splice plate location.

NX CITO Line

Height	Nominal	54	53	55
105 mm	4 inches			

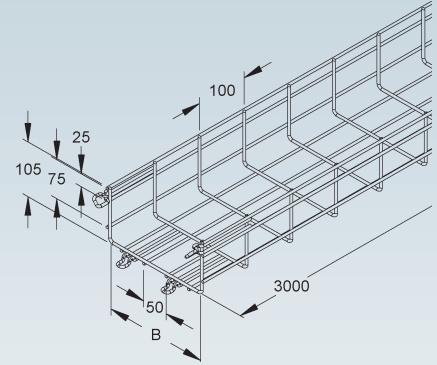

Flexible Horizontal and Vertical Elbow

with integrated splice connector

Model no.	Inside width B mm Inch	Weight per 100 pcs kg	Pack/ Box Qty
✓ MTCE 105.100 V	100 3,9	38,4	1
✓ MTCE 105.150 V	150 5,9	42,6	1
✓ MTCE 105.200 V	200 7,9	93,9	1
✓ MTCE 105.300 V	300 11,8	154,3	1

Suitable for: wire mesh tray MTC 105...

NX CITO Line

Height	Nominal	54	53	55
105 mm	4 inches			

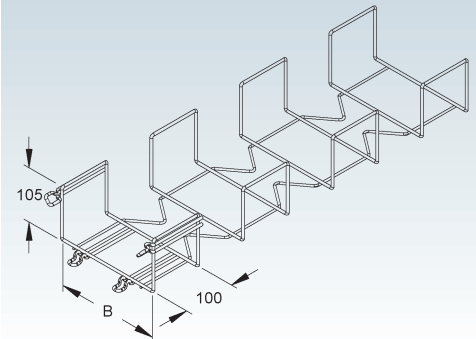

WIRE MESH TRAY SYSTEM

Peaked Snapon Cover for Wire Mesh Tray

with 7.5° pitch

	Model no.	Width B		Thick-ness t mm	Weight per 100 m kg	Pack/Box Qty
		mm	Inch			
S	MTCC 50/7.5° S	62,5	2,5	0,50	37,82	3 m
S	MTCC 100/7.5° S	111,0	4,4	0,75	86,04	3 m
S	MTCC 150/7.5° S	161,0	6,3	0,75	115,61	3 m
S	MTCC 200/7.5° S	213,0	8,4	0,75	146,02	3 m
S	MTCC 300/7.5° S	315,0	12,4	0,90	248,69	3 m
S	MTCC 400/7.5° S	416,0	16,4	0,90	314,86	3 m
S	MTCC 450/7.5° S	465,7	18,3	0,90	350,49	3 m
S	MTCC 500/7.5° S	517,0	20,4	1,00	429,58	3 m
S	MTCC 600/7.5° S	617,0	24,3	1,00	508,76	3 m

These covers are intended for horizontal installations only. Please use GRDHL... clamps to secure the cover in all vertical installations.

Suitable for: wire mesh tray MTC...

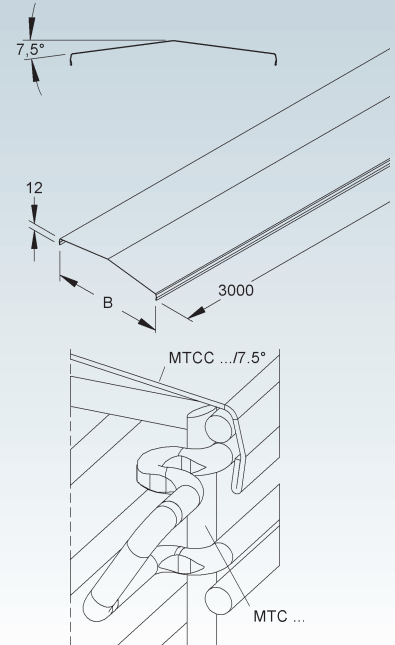

Retaining Bracket

	Model no.	Weight per 100 pcs kg	Pack/Box Qty
S	GRDHL 30 S	3,27	50

Suitable for: wire mesh tray covers GRD... and MTCC...

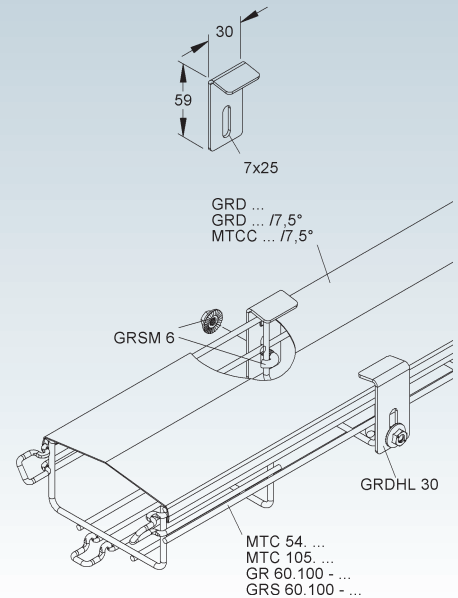

Universal Splice Bolt for Wire Mesh Tray

Model no.	Strength category	Weight per 100 pcs kg	Pack/Box Qty
V GRHKM 6X15 V	8.8	1,78	50

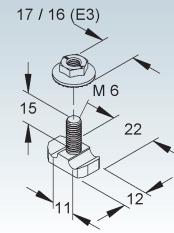

Bendable Multifunction Splice Bar

Model no.	Weight per 100 pcs kg	Pack/Box Qty
V GTVL 300 V	8	50

Available also in F and E4 finish as well as in 600 and 1200 mm length. GRSM 6 hardware not included.

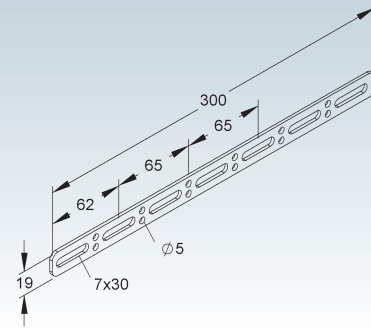

Square Splice Washer

Model no.	Weight per 100 pcs kg	Pack/Box Qty
V GTL 20 V	0,6	50

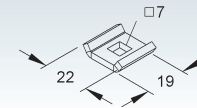

U-Shaped Square Washer

Model no.	Weight per 100 pcs kg	Pack/Box Qty
V GTL 30 V	1,5	50

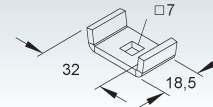

Use GTL 20 and GTL 30 with FLM 6X20 as heavy duty splice kit.

Large Square Splice Washer/Clamping Bracket

Model no.	Weight per 100 pcs kg	Pack/Box Qty
V GTL 40 V	3,6	50

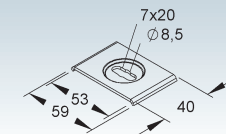

Mushroom Head Bolt

serrated flange nut included

Model no.	Thread M	Length L mm Inch	Strength category	Weight per 100 pcs kg	Pack/Box Qty
G FLM 6X20 G	6	20 0,8	-	0,9	100

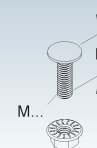

J-Hook Bolt

Model no.	Thread M	Weight per 100 pcs kg	Pack/Box Qty
V GRSM 6 V	6	1,09	50

for attaching wire mesh tray

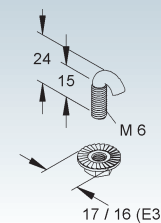

WIRE MESH TRAY SYSTEM ACCESSORIES

Divider

Model no.	Height H mm Inch	Thick-ness t mm	Acc. incl.	Weight per 100 m kg	Pack/Box Qty
S RW 60	55 2,2	0,75	4 FLM 6X12	50,42	10 x 3 m
S RW 110	98 3,9	0,90	4 FLM 6X12	90,29	10 x 3 m

to separate wires and cables of different voltage levels or with different functions

Height 60 mm	Nominal 2 3/8 inches	Height 110 mm	Nominal 4 3/8 inches	
--------------------	----------------------------	---------------------	----------------------------	--

69

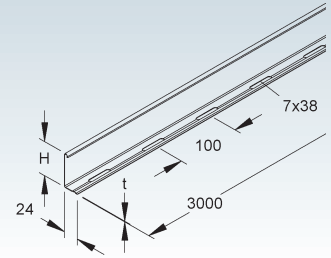

Splice Plate for Divider

Model no.	Height H mm Inch	Length L mm Inch	Weight per 100 pcs kg	Pack/Box Qty
E2 RTV 50 E2	46,5 1,8	80 3,1	1,18	20
E2 RTV 110 E2	97,5 3,8	80 3,1	2,50	20

for positive locking connections and proper bonding of dividers

	Height 110 mm	Nominal 4 3/8 inches	Height 50 mm	Nominal 2 inches	
--	---------------------	----------------------------	--------------------	------------------------	--

69

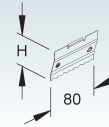

Mounting Clamp for Divider

Model no.	Acc. incl.	Weight per 100 pcs kg	Pack/Box Qty
S GRTB 6 S	1 FLM 6X12 V	1,7	20

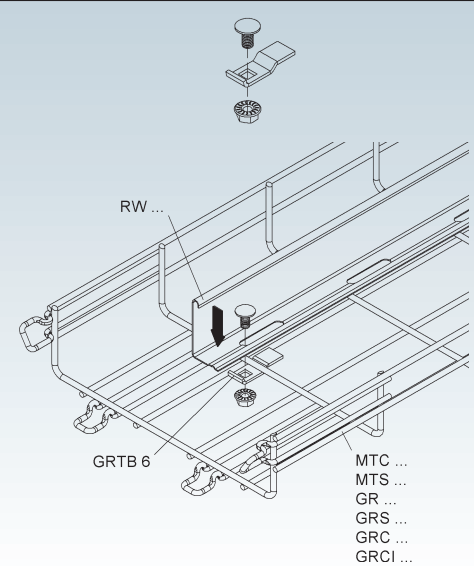

Mounting Clip for Divider

boltless

Model no.	Height H		Width B		Length L		Wire diameter	Weight per 100 pcs kg	Pack/Box Qty
	mm	Inch	mm	Inch	mm	Inch			
E2 MTCDC 24 E2	23	0,9	25	1	32	1,3	3,9 - 6	0,93	50

for boltless installation of RW dividers in wire mesh tray

Suitable for: wire mesh tray with a wire diameter 3,9-6 mm



59

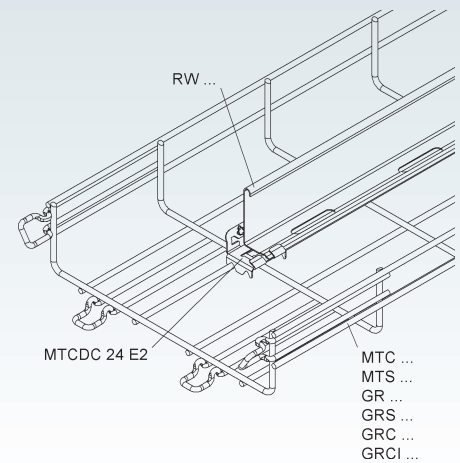
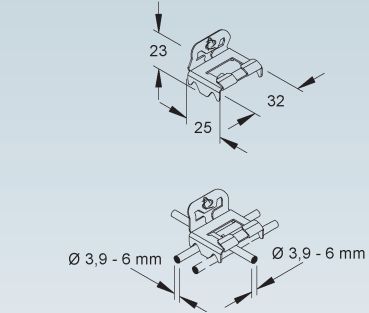

Cable Drop Out

Model no.	Weight per 100 pcs kg	Pack/Box Qty
S GTKA 50 S	16,5	10



55

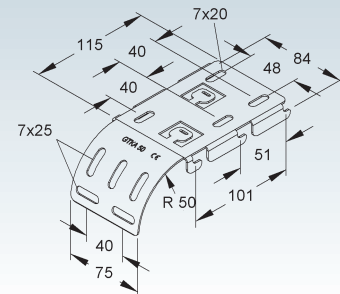

Wall and Box Mount Bracket for Wire Mesh Tray

Model no.	Weight per 100 pcs kg	Pack/Box Qty
S GTMB 65 S	8,97	20

Suitable for: wire mesh tray MTC... only

Does not work with GR... or GRS... trays!



54

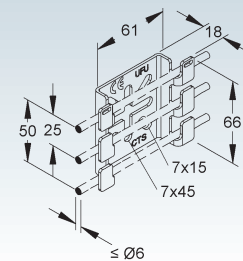

WIRE MESH TRAY SYSTEM ACCESSORIES

Trapeze Hanger for Wire Mesh Tray

Model no.	Weight per 100 pcs kg	Pack/Box Qty
S GTAB 8 S	7	20

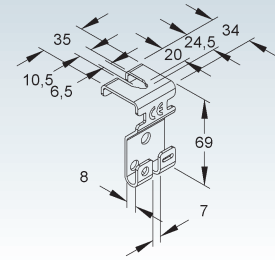

Attachment Clip for Wire Mesh Tray

Model no.	Weight per 100 pcs kg	Pack/Box Qty
S GTWAB 50 S	2,6	50

for attaching wire mesh tray to walls and brackets

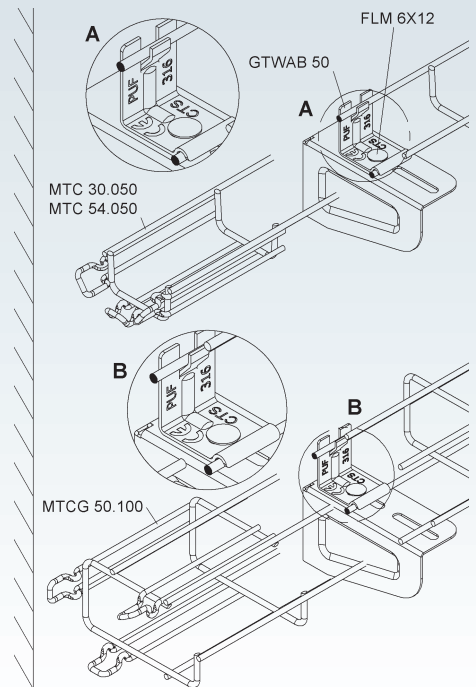
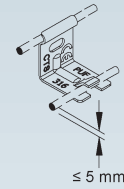
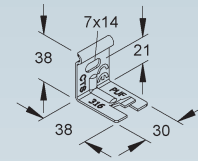

Wire Mesh Mounting Clamp

horizontal and vertical

Model no.	Total length L		Support length L1	F1 Load bearing capacity kN	F2 Load bearing capacity kN	Acc. incl.	Weight per 100 pcs kg	Pack/ Box Qty
	mm	Inch						
S GRKHV 173 S	173	6,8	148	0,6	0,9	1 SK 8X35 V	36,74	10

for mounting wire mesh tray to horizontal or vertical I-beam flanges of up to 20 mm thickness

Suitable for: wire mesh trays GR..., GRS... and MTC... 100-... series



56

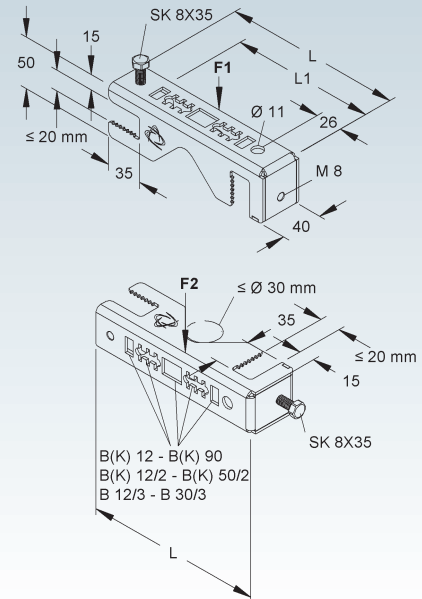

Bracket

Model no.	Height H	Length L		Max. load F at L/2 kN	Weight per 100 pcs kg	Pack/ Box Qty
		mm	Inch			
S KTAC 100 S	77	3	118 4,6	0,60	13	20
S KTAC 150 S	77	3	168 6,6	0,60	16	20
S KTAC 200 S	77	3	218 8,6	0,55	18	20
S KTAC 300 S	107	4,2	318 12,5	1,00	47	20

Suitable for: Suitable for wire mesh tray with 50 mm distance between lengthwires and a wire diameter in between 3.9 and 5 mm.

The load rating shown is only valid for proper anchorage to the building structure.



55

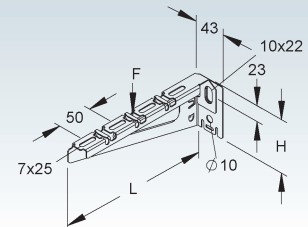

WIRE MESH TRAY SYSTEM ACCESSORIES

C-Bracket for Wire Mesh Tray

	Model no.	Height H		Length L		Upper net width L1 mm	Lower net width L2 mm	Adm. load F1 at L2/2 kN	Adm. load F2 at L2/2 kN	Adm. load F3 at L1/2 kN	Weight per 100 pcs kg	Pack/Box Qty
		mm	Inch	mm	Inch							
S	ZC 100 S	240	9,4	150,0	5,9	133,0	110	0,9	1,5	1,5	40,12	10
S	ZC 150 S	240	9,4	201,5	7,9	179,5	160	0,9	1,5	1,5	63,22	10
S	ZC 200 S	240	9,4	253,0	10	236,0	210	0,8	1,5	1,5	76,47	10
S	ZC 300 S	280	11	365,0	14,4	308,0	310	0,5	1,5	1,5	114,50	10

for mounting on walls and ceilings with M10 hardware

Suitable for: Suitable for wire mesh tray with 50 mm distance between lengthwires and a wire diameter in between 3.9 and 5 mm.

The load rating shown is only valid for proper anchorage to the building structure.

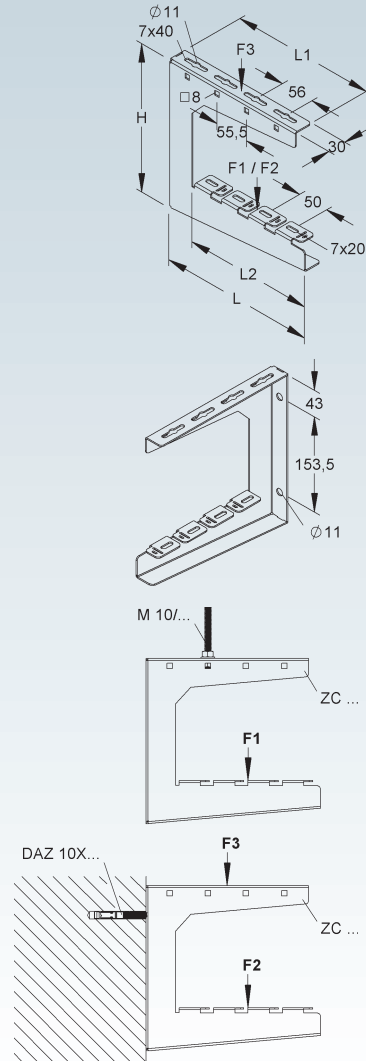

Hold Down Clip for Wire Mesh Tray

boltless

	Model no.	Height H		Width B		Length L		Wire diameter mm	Weight per 100 pcs kg	Pack/Box Qty
		mm	Inch	mm	Inch	mm	Inch			
E2	MTCS22 E2	16,5	0,6	63,5	2,5	32	1,3	3,9 - 6	1,68	25

for boltless installation of wire mesh tray onto framing channels with 22 mm slotwidth

Suitable for: framing channel 2996Z and 2996ZD

Please stagger in reverse order to improve stability.

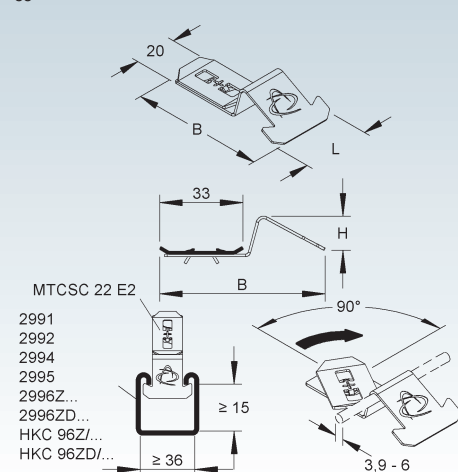

Universal Attachment Bracket

boltless

Model no.	Height H		Width B		Length L		Wire diameter	Weight per 100 pcs kg	Pack/ Box Qty
	mm	Inch	mm	Inch	mm	Inch			
S MTCUP 100 S	94	3,7	10	0,4	104	4,1	3,9 - 6	6,13	25

for attaching junction boxes, yoke clamps as well as various small sizes of cable glands and conduit to the bottom or the side of MTC and GR(S) wire mesh trays with a minimum width of 100 mm (4")

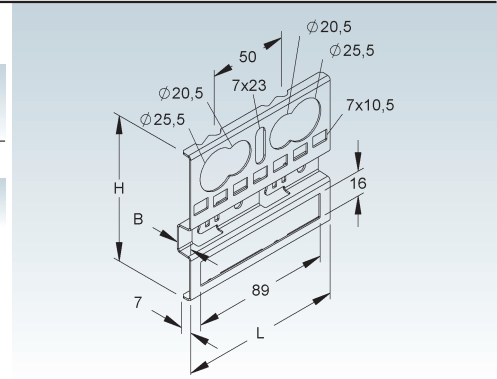

WIRE MESH TRAY SYSTEM E3

Available Side Rail Heights

▲ Height	Nominal	▲ Height	Nominal
60	2 3/8	110	4 3/8
mm	inches	mm	inches

SYSTEM			
	Wire Mesh Tray	GR 60...	Page 168
	Wire Mesh Tray	GRS 60...	Page 169
	Wire Mesh Tray	GRS 110...	Page 169
ACCESSORIES	Peaked Snapon Cover for Wire Mesh Tray	GRD...	Page 170
	Retaining Bracket	GRDHL 30 E3	Page 170
	Universal Splice Bolt for Wire Mesh Tray	GRHKM 6X15 E3	Page 171
	Boltless Splice Plate	GRVS...	Page 171
	Bendable Multifunction Splice Bar	GTVL 300 E3	Page 171
	Square Splice Washer	GTL 20 E3	Page 171
	U-Shaped Square Washer	GTL 30 E3	Page 171
	Large Square Splice Washer/Clamping Bracket	GTL 40 E3	Page 171
	Mushroom Head Bolt	FLM 6X20 E4	Page 171
	Divider	RW...	Page 172
	Splice Plate for Divider	RTV...	Page 172
	Mounting Clamp for Divider	GRTB 6 E3	Page 172
	Mounting Clip for Divider	MTCDC 24 E2	Page 173
	Cable Drop Out	GTKA 50 E3	Page 173
	Wire Mesh Mounting Bracket	GRBP 6 E3	Page 174
	Universal Wire Mesh Mounting Bracket	GRWGK 10 E3	Page 174
	Wire Mesh Mounting Bracket	GRWB 10 E3	Page 175
	Wall and Box Mount Bracket	GRMB 50 E3	Page 176
	Hold Down Clip for Wire Mesh Tray	MTCSC 22 E2	Page 176
	Universal Attachment Bracket	MTCUP 100 E3	Page 177



Load/Span Class Designation in accordance with NEMA VE 1 and CSA C22.2 No. 126.1

Niedax Series	Minimum Area		Load class in accordance to NEMA VE 1		
	(calculational) mm ² / in. ²	in accordance to NEMA VE 2 mm ² / in. ²	Rated Load Kg/m / lb./ft.	Support spacing m / ft.	Load/Span Class
GRX 60.060 E3	38 / 0.06	-	16.5 / 11.1	2 / 6.6	-
GRX 60.100 E3	58 / 0.09	-	16.5 / 11.1	2 / 6.6	-
GRX 60.150 E3	67 / 0.10	-	16.5 / 11.1	2 / 6.6	-
GRX 60.200 E3	77 / 0.12	-	16.5 / 11.1	2 / 6.6	-
GRX 60.300 E3	126 / 0.19	-	31.5 / 21.2	2 / 6.6	-
GRSX 60.100 E3	95 / 0.15	-	25.5 / 17.1	2 / 6.6	-
GRSX 60.150 E3	111 / 0.17	-	25.5 / 17.1	2 / 6.6	-
GRSX 60.200 E3	127 / 0.19	-	25.5 / 17.1	2 / 6.6	-
GRSX 60.300 E3	159 / 0.25	129 / 0.2	63 / 42.3	2 / 6.6	A
GRSX 60.400 E3	191 / 0.3	129 / 0.2	63 / 42.3	2 / 6.6	A
GRSX 110.100 E3	127 / 0.19	-	50 / 33.6	2 / 6.6	-
GRSX 110.200 E3	159 / 0.25	129 / 0.2	50 / 33.6	2 / 6.6	-
GRSX 110.300 E3	191 / 0.30	129 / 0.2	60 / 40.3	2 / 6.6	-
GRSX 110.400 E3	223 / 0.35	129 / 0.2	60 / 40.3	2 / 6.6	-

WIRE MESH TRAY SYSTEM E3

Wire Mesh Tray

Model no.	Height H mm Inch	Width B mm Inch	Steel wire- Ø mm	Weight per 100 m kg	Pack/Box Qty
E3 GR 60.060 E3	60 2,4	60 2,4	3,5	42,56	2 x 3 m

Load Chart: q = uniformly distributed load (tested according to DIN EN IEC 61537 standard)

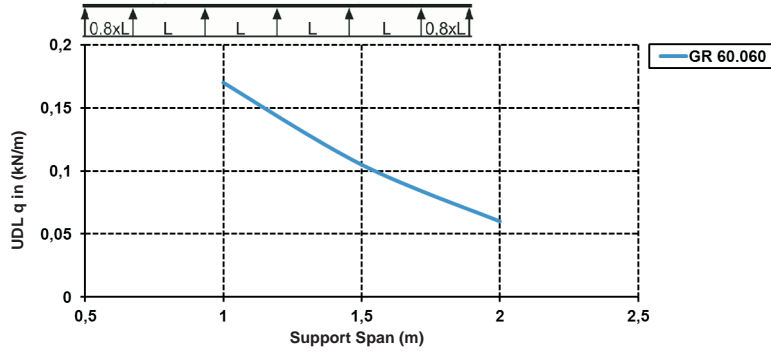

Specified load ratings are independent of splice plate location.

Height 60 mm
Nominal 2 3/8 inches

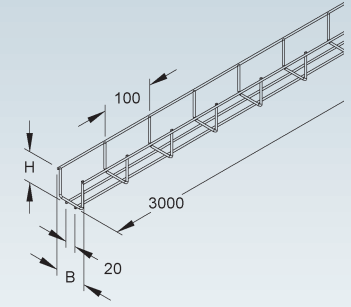

Wire Mesh Tray

Model no.	Height H mm Inch	Width B mm Inch	Steel wire- Ø mm	Weight per 100 m kg	Pack/Box Qty
E3 GR 60.100 E3	60 2,4	100 3,9	3,5	60,87	2 x 3 m
E3 GR 60.150 E3	60 2,4	150 5,9	3,5	72,41	2 x 3 m
E3 GR 60.200 E3	60 2,4	200 7,9	3,5	83,95	2 x 3 m
E3 GR 60.300 E3	60 2,4	300 11,8	4,0	139,45	2 x 3 m

Load Chart: q = uniformly distributed load (tested according to DIN EN IEC 61537 standard)

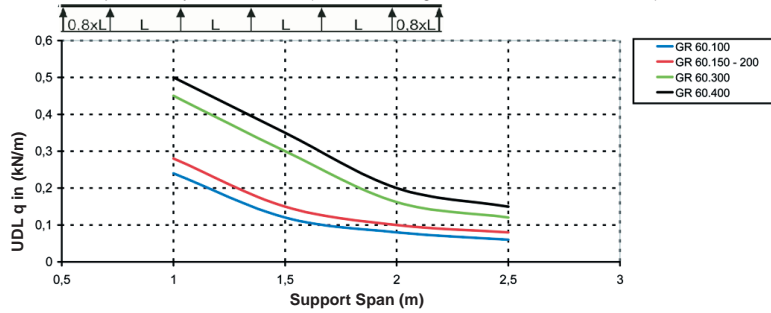

Specified load ratings are independent of splice plate location.

Height 60 mm
Nominal 2 3/8 inches

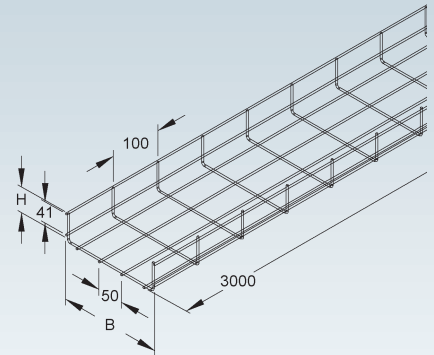
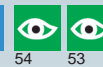

Wire Mesh Tray

Model no.		Height H	Width B	Steel wire- Ø	Dist. A	Weight per 100 m	Pack/ Box Qty
		mm Inch	mm Inch	mm	mm Inch	kg	
E3	GRS 60.100 E3	60 2,4	100 3,9	4,5	37,5 1,5	99,76	2 x 3 m
E3	GRS 60.150 E3	60 2,4	150 5,9	4,5	37,5 1,5	118,84	2 x 3 m
E3	GRS 60.200 E3	60 2,4	200 7,9	4,5	37,5 1,5	137,05	2 x 3 m
E3	GRS 60.300 E3	60 2,4	300 11,8	4,5	37,5 1,5	176,07	2 x 3 m
E3	GRS 60.400 E3	60 2,4	400 15,7	4,5	37,5 1,5	214,23	2 x 3 m

Splice plates have to be ordered separately.

Load Chart: q = uniformly distributed load (tested according to DIN EN IEC 61537 standard)

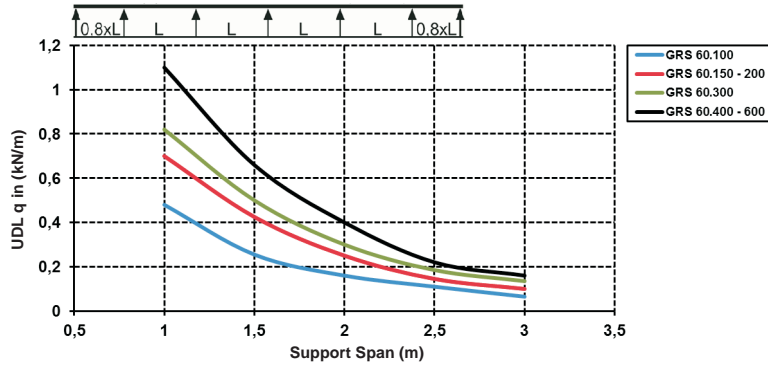

Specified load ratings are independent of splice plate location.

Consult factory for availability of GRS tray in stainless AISI 304 & 316.

Height 60 mm
Nominal 2 3/8 inches
54

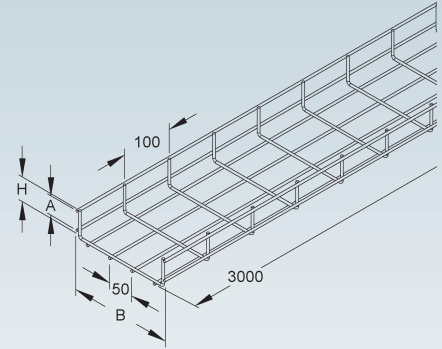

Wire Mesh Tray

Model no.		Height H	Width B	Thickness t	Weight per 100 m	Pack/ Box Qty
		mm Inch	mm Inch	mm	kg	
E3	GRS 110.100 E3	110 4,3	100 3,9	4,5	137,92	2 x 3 m
E3	GRS 110.200 E3	110 4,3	200 7,9	4,5	176,08	2 x 3 m
E3	GRS 110.300 E3	110 4,3	300 11,8	4,5	214,24	2 x 3 m
E3	GRS 110.400 E3	110 4,3	400 15,7	4,5	252,40	2 x 3 m

Splice plates have to be ordered separately.

Load Chart: q = uniformly distributed load (tested according to DIN EN IEC 61537 standard)

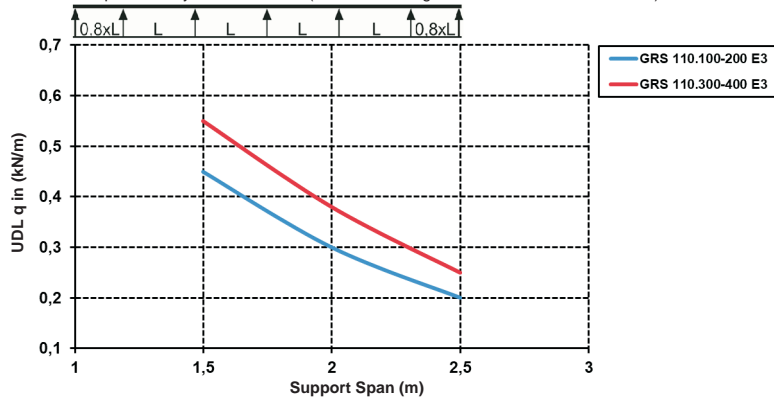

Specified load ratings are independent of splice plate location.

Height 110 mm
Nominal 4 3/8 inches
54

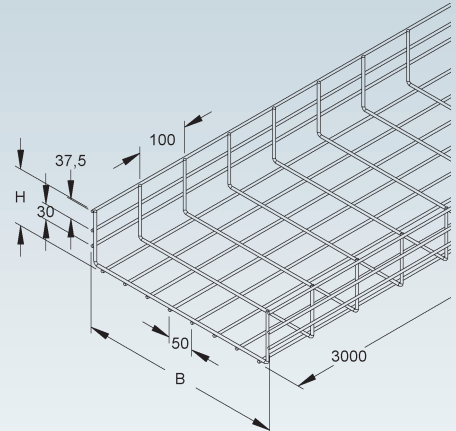

WIRE MESH TRAY SYSTEM E3

Peaked Snapon Cover for Wire Mesh Tray

with 7.5° pitch

Model no.	Inside dimension B mm Inch	Thick-ness t mm	Weight per 100 m kg	Pack/Box Qty
E3 GRD 60/7.5° E3	58,5 2,3	0,8	58,47	2 x 3 m
E3 GRD 100/7.5° E3	97,0 3,8	0,8	83,39	2 x 3 m
E3 GRD 150/7.5° E3	147,0 5,8	0,8	115,27	2 x 3 m
E3 GRD 200/7.5° E3	197,0 7,8	0,8	147,20	2 x 3 m
E3 GRD 300/7.5° E3	297,0 11,7	0,8	210,88	2 x 3 m
E3 GRD 400/7.5° E3	397,0 15,6	0,8	274,66	2 x 3 m

These covers are intended for horizontal installations only. Please use special clamps (e.g. WA 25) to secure the cover in all vertical installations.

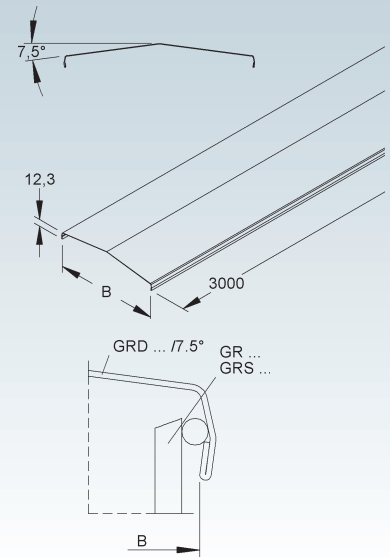

Retaining Bracket

Model no.	Weight per 100 pcs kg	Pack/Box Qty
E3 GRDHL 30 E3	3,29	50

Suitable for: wire mesh tray covers GRD... and MTCC...
For securing covers on vertically mounted trays.
GRSM 6 J-hook bolts are not included.

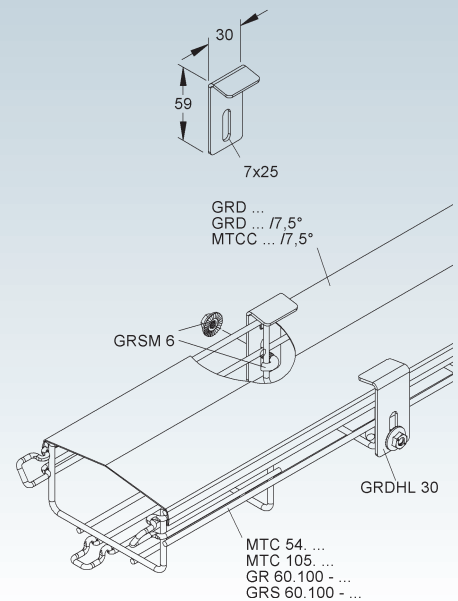

Universal Splice Bolt for Wire Mesh Tray

Model no.	Strength category	Weight per 100 pcs kg	Pack/Box Qty
E3 GRHKM 6X15 E3	70	1,78	50

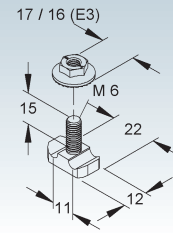

Boltless Splice Plate

Model no.	Height H	Length L	For wire gauge	Weight per 100 pcs kg	Pack/Box Qty
	mm Inch	mm Inch	mm Inch		
E3 GRVS 4 E3	37 1,5	220 8,7	3,5 - 4,0	8,30	20
E3 GRVS 5 E3	38 1,5	220 8,7	4,0 - 5,0	8,05	20

Suitable for: works only with wire mesh trays GR... and GRS...

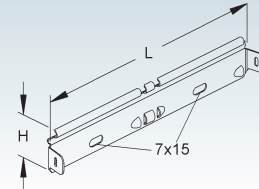
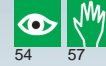

Bendable Multifunction Splice Bar

Model no.	Weight per 100 pcs kg	Pack/Box Qty
E3 GTVL 300 E3	8	50

Available also in F and E4 finish as well as in 600 and 1200 mm length. GRSM 6 hardware not included.

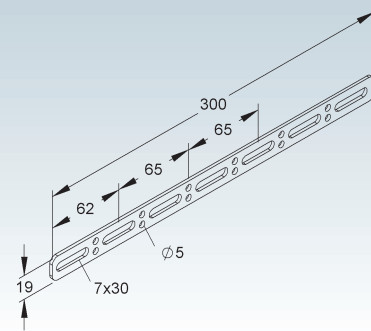

Square Splice Washer

Model no.	Weight per 100 pcs kg	Pack/Box Qty
E3 GTL 20 E3	0,6	50

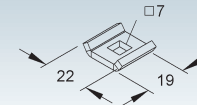

U-Shaped Square Washer

Model no.	Weight per 100 pcs kg	Pack/Box Qty
E3 GTL 30 E3	1,5	50

Use GTL 20 and GTL 30 with FLM 6X20 as heavy duty splicekit.

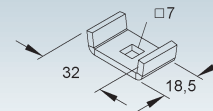

Large Square Splice Washer/Clamping Bracket

Model no.	Weight per 100 pcs kg	Pack/Box Qty
E3 GTL 40 E3	4	50

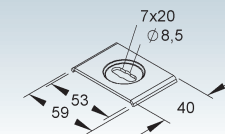

Mushroom Head Bolt

serrated flange nut included

Model no.	Thread M	Length L	Strength category	Weight per 100 pcs kg	Pack/Box Qty
		mm Inch			
E4 FLM 6X20 E4	6	20 0,8	-	0,9	100

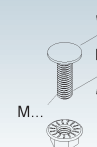

WIRE MESH TRAY SYSTEM E3 ACCESSORIES

Divider

Model no.	Height H mm Inch	Thick-ness t mm	Acc. incl.	Weight per 100 m kg	Pack/Box Qty
E3 RW 60 E3	55 2,2	0,8	4 FLM 6X12 E3	53,97	10 x 3 m
E3 RW 110 E3	98 3,9	0,9	4 FLM 6X12 E3	90,88	10 x 3 m

to separate wires and cables of different voltage levels or with different functions

Height
110 mm
Nominal
4 3/8 inches
69

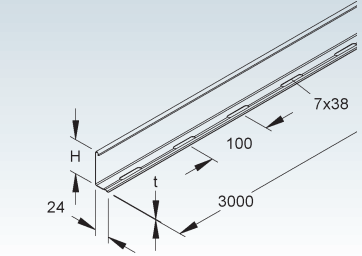

Splice Plate for Divider

Model no.	Height H mm Inch	Length L mm Inch	Weight per 100 pcs kg	Pack/Box Qty
E2 RTV 60 E2	54,5 2,1	80 3,1	1,39	20
E2 RTV 110 E2	97,5 3,8	80 3,1	2,50	20

for positive locking connections and proper bonding of dividers

Height
60 mm
Nominal
2 3/8 inches
Height
110 mm
Nominal
4 3/8 inches
69

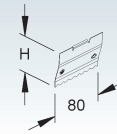

Mounting Clamp for Divider

Model no.	Acc. incl.	Weight per 100 pcs kg	Pack/Box Qty
E3 GRTB 6 E3	1 FLM 6X12 E3	1,73	20

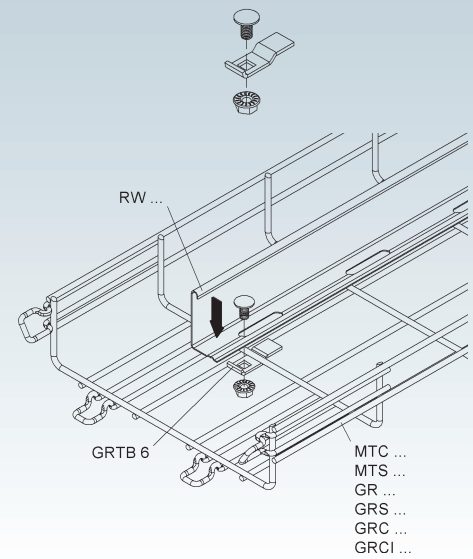

Mounting Clip for Divider

boltless

Model no.	Height H		Width B		Length L		Wire diameter	Weight per 100 pcs kg	Pack/Box Qty
	mm	Inch	mm	Inch	mm	Inch			
E2 MTCDC 24 E2	23	0,9	25	1	32	1,3	3,9 - 6	0,93	50

for boltless installation of RW dividers in wire mesh tray

Suitable for: wire mesh tray with a wire diameter 3,9-6 mm



59

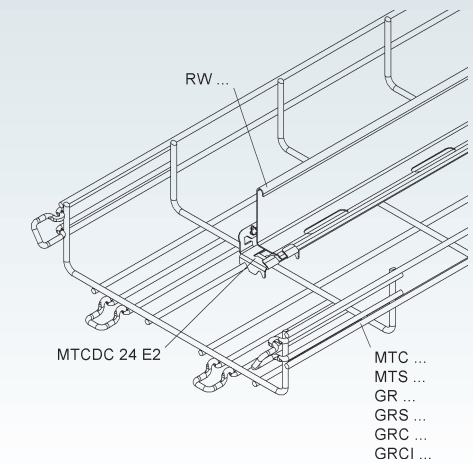
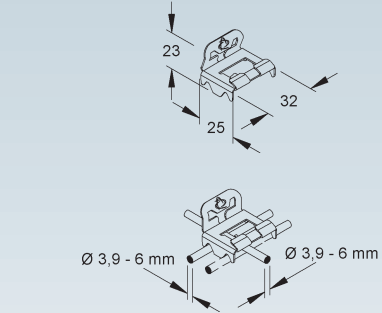

Cable Drop Out

Model no.	Weight per 100 pcs kg	Pack/Box Qty
E3 GTKA 50 E3	14	10

Suitable for: wire mesh trays MTC... and GRS...



55

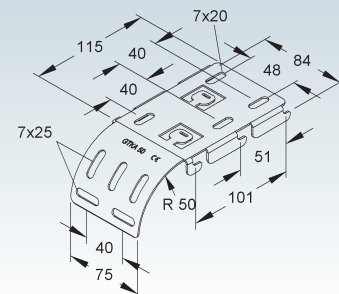

WIRE MESH TRAY SYSTEM E3 ACCESSORIES

Wire Mesh Mounting Bracket

Model no.	Weight per 100 pcs kg	Pack/Box Qty
E3 GRBP 6 E3	1,06	50

Suitable for: wire mesh trays GR..., GRS... and MTC...

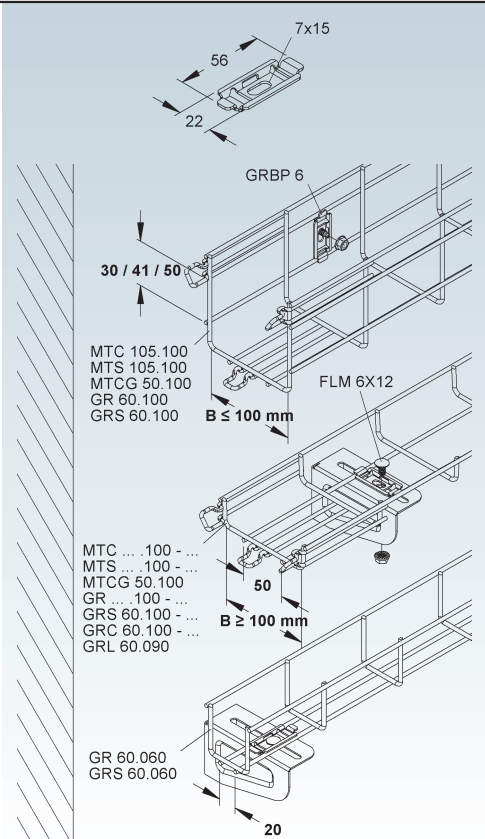

Universal Wire Mesh Mounting Bracket

Model no.	Weight per 100 pcs kg	Pack/Box Qty
E3 GRWGK 10 E3	5,8	25

Can be used for all kinds of wire mesh tray from wire gauge 3.0 mm to 6.0 mm.

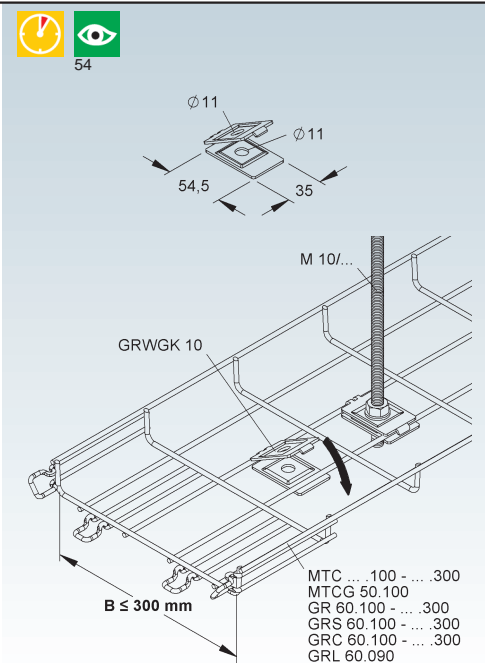

Wire Mesh Mounting Bracket

Model no.	Weight per 100 pcs kg	Pack/Box Qty
E3 GRWB 10 E3	5,8	25

for wall mounting of wire mesh tray MTC...
for floor mounting of wire mesh trays MTC... and GR...

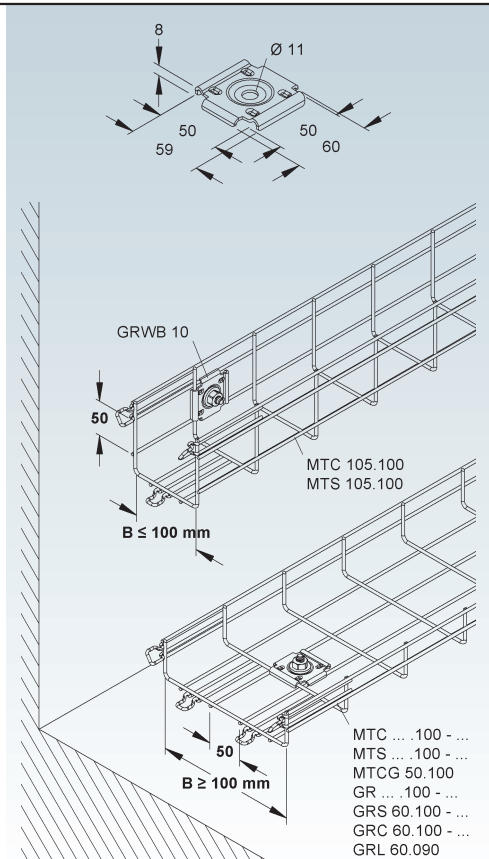

WIRE MESH TRAY SYSTEM E3 ACCESSORIES

Wall and Box Mount Bracket

Model no.	Weight per 100 pcs kg	Pack/Box Qty
E3 GRMB 50 E3	7,27	20

Suitable for: only wire mesh trays GR... and GRS...

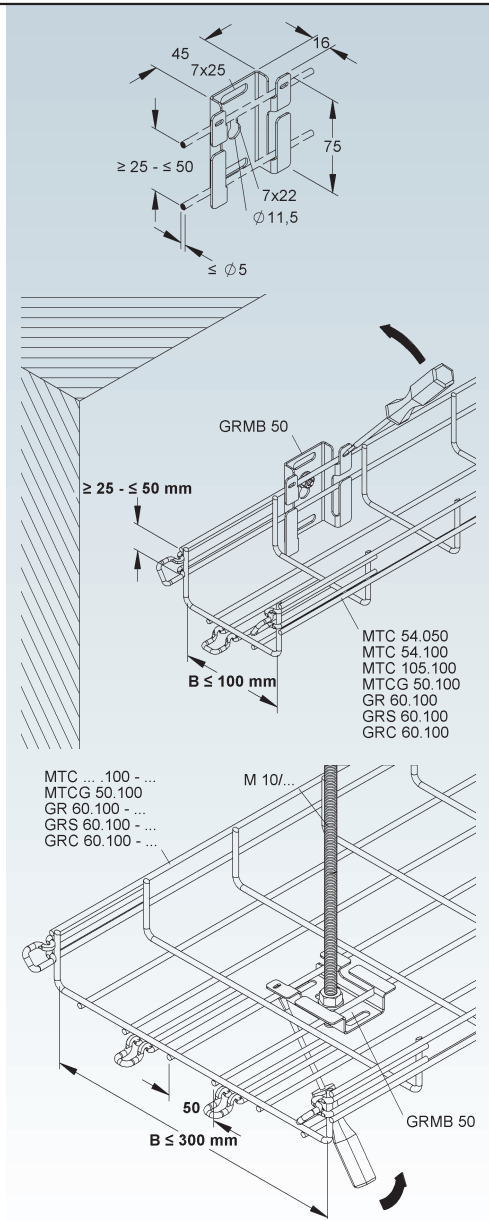

Hold Down Clip for Wire Mesh Tray

boltless

Model no.	Height H	Width B	Length L	Wire diameter	Weight per 100 pcs kg	Pack/Box Qty
E2 MTCSC 22 E2	16,5 0,6	63,5 2,5	32 1,3	3,9 - 6	1,68	25

for boltless installation of wire mesh tray onto framing channels with 22 mm slotwidth

Suitable for: framing channel 2996Z and 2996ZD

Please stagger in reverse order to improve stability.

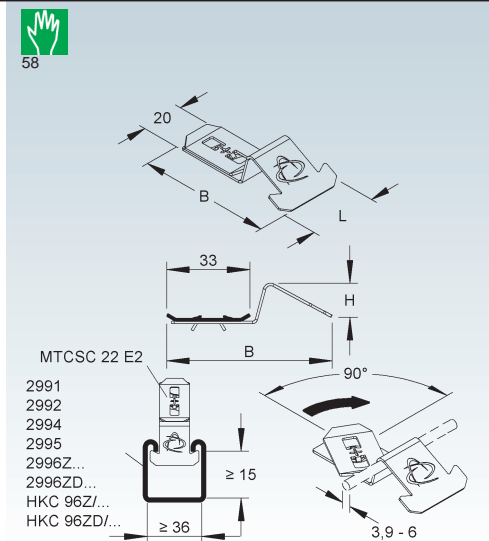

Universal Attachment Bracket

boltless

Model no.	Height H		Width B		Length L		Wire diameter	Weight per 100 pcs kg	Pack/ Box Qty
	mm	Inch	mm	Inch	mm	Inch			
E3 MTCUP 100 E3	94	3,7	10	0,4	104	4,1	3,9 - 6	6,17	25

for attaching junction boxes, yoke clamps as well as various small sizes of cable glands and conduit to the bottom or the side of MTC and GR(S) wire mesh trays with a minimum width of 100 mm (4")

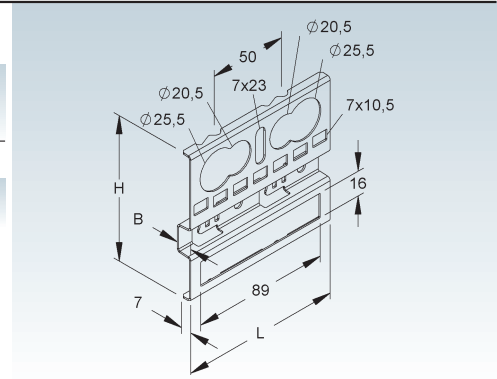

CABLE TRAY SYSTEM

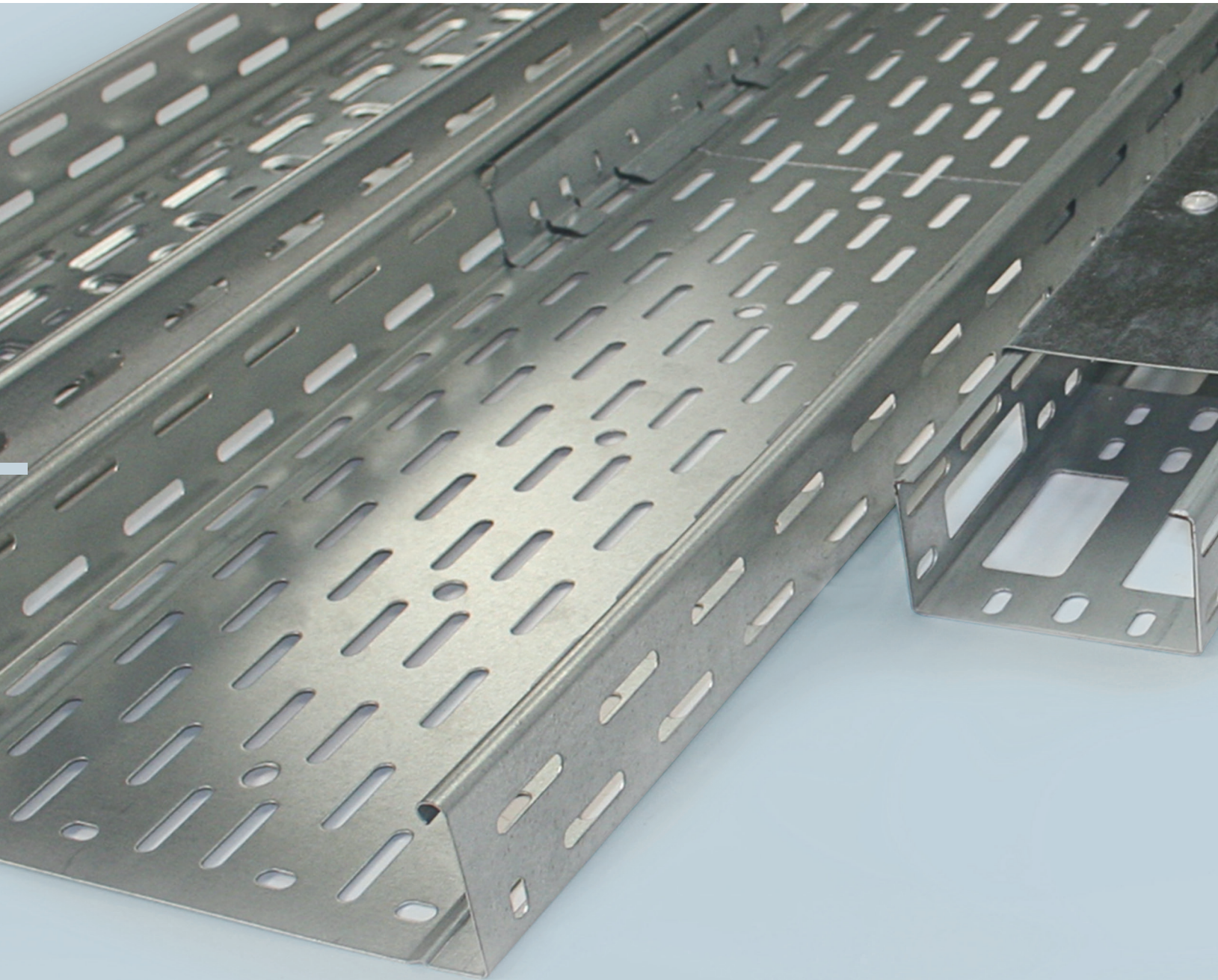



CABLE TRAY SYSTEM

- Cable Tray
- Dividers
- Fittings
- Covers
- Accessories

The Niedax Cable Tray is an extremely versatile and cost effective solution for your cabling needs. You can select from a wide range of tray sizes, fittings and accessories in various material thicknesses and finishes. Niedax Cable Tray is adaptable to your special needs, customized dimensions are available upon request.

All straight sections of cable tray as well as their corresponding system components (fittings, splice plates, covers, ...) are classified by UL in accordance with NEMA VE 1 for the USA and CSA C22.1 No. 126.1 for Canada.

An 'X' in the part number will be added for labeling according to UL instructions (see catalog page 40).



CABLE TRAY SYSTEM

Available Side Rail Heights

SYSTEM	Distribution Cable Tray	RSV 50...	Page 184
ACCESSORIES	Turnbolt Lock	RDRS...	Page 186
	Edge Protection Ring	KSR...	Page 185
	Divider	RW 50...	Page 185
	Splice Plate for Divider	RTV 50 E2	Page 185
	Cover for Distribution Cable Tray	RDSV...	Page 185
	Universal Splice Plate	RVV 50...	Page 186
	Extension Horizontal Tee	RTAK...	Page 187
	Cover for Horizontal Extension Tee	RTAKDV...	Page 187
	Horizontal Elbow 90°	RESK...	Page 187
	Cover for 90° Horizontal Elbow	RESKDV...	Page 187
	Horizontal Tee	RTSK...	Page 187
	Cover for Horizontal Tee	RTSKDV...	Page 188
	Raised Cover Clamp	RDAH 30...	Page 188



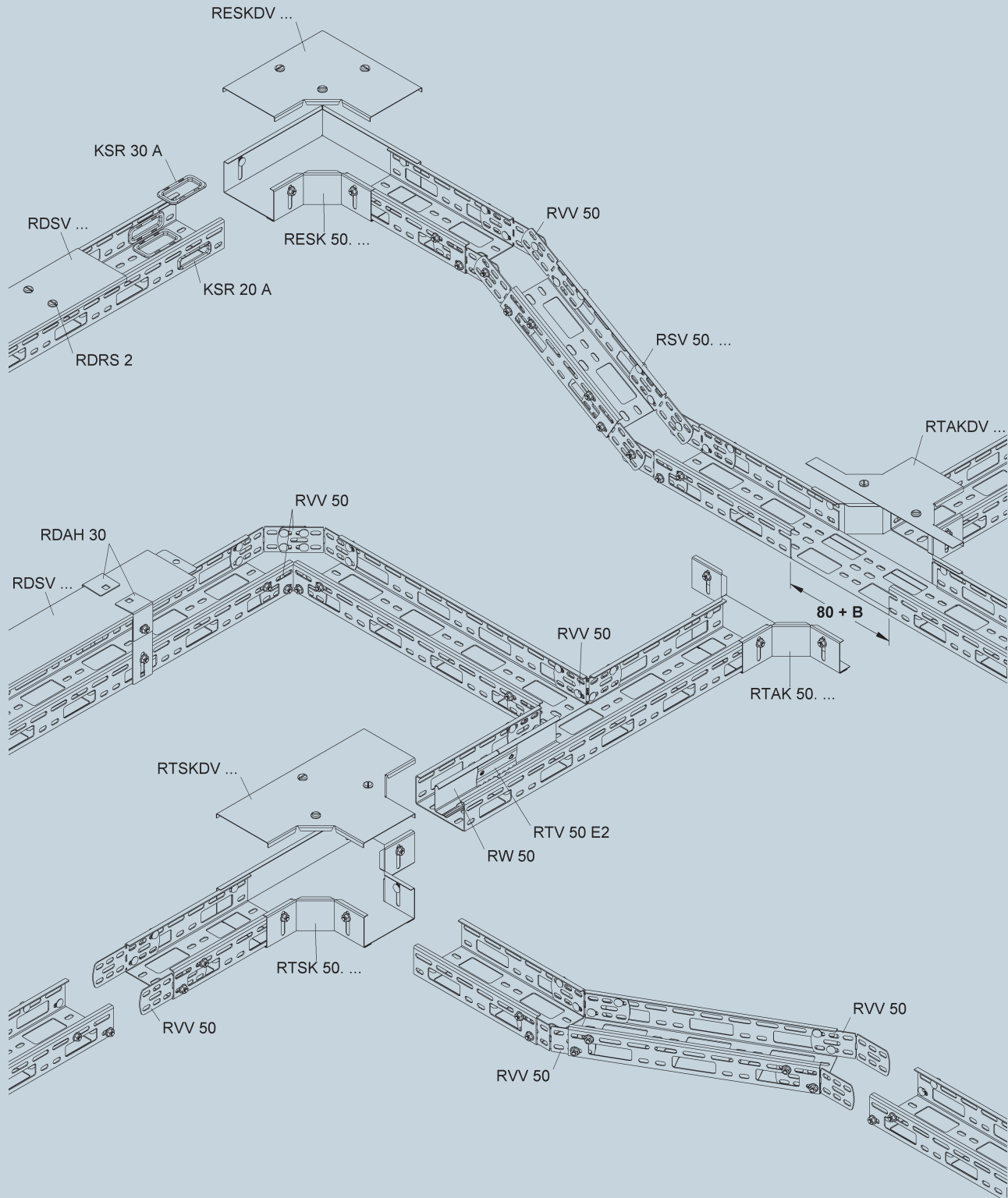

One-Piece Cable Tray Specifications:

A. CABLE TRAY DESIGN

1. Cable Tray shall be made of straight sections, fittings and accessories as defined in the latest NEMA standards per NEMA VE-1. Standard cable trays shall be UL classified as equipment grounding conductors.

B. MATERIAL

1. **Pre-galvanized steel.** The structural quality of the steel shall meet the minimum yield and tensile strength of the ASTM standards (ASTM A 653) with G 90 coating thickness. All cable trays to be labeled for material identification purposes.
2. **Hot dipped galvanized steel.** All trays to be hot-dipped galvanized in accordance with ASTM A123. All trays to be labeled for material identification.
3. **Stainless steel.** All trays are to be constructed of AISI type 304 or type 316 stainless steel. All trays to be labeled for material identification.

C. TRAY TYPES

1. **Ventilated cable tray.** Trays are to be fabricated from continuous roll-formed structural quality steel. Tray shall be ventilated on both the bottom of the tray and on the sides for maximum ventilation of the cables.
2. **Solid cable tray.** Trays are to be fabricated from continuous roll-formed structural quality steel. Sides are to be solid as well as bottom for maximum cable enclosure and support.
3. **Distribution cable tray.** Trays are to be fabricated from continuous roll-formed structural quality steel. Tray shall be ventilated on sides and bottom and will also contain larger openings on both bottom and side for cables to exit and enter the cable tray. Openings shall be insulated with plastic edge protection rings that are purchased separately for cable protection where needed.

D. TRAY SIZE

1. **Height:** Trays shall have an overall height of 2", 2.3", 3.3", and 4.3" (50, 60, 85 and 110 mm). Loading depth is the same as the overall height, as there are no rungs to reduce the fill of the tray.
2. **Width:** Widths shall be 2", 4", 6", 8", 12", 16", 20" and 24" (50, 100, 150, 200, 300, 400, 500 and 600 mm).
3. **Length:** Length shall be a nominal 10' or 3 meters.

E. ACCESSORIES

1. **Covers.** Covers shall be supplied as an option to protect tray cable where needed. Covers will be solid and have the option of containing three pair of turn-bolt locks to secure the covers to the lips of the cable tray. Covers can also be plain, and locks can be installed separately.
2. **Splice plates.** Splice plates shall be supplied with the straight sections of the tray and are installed with four sets of nuts/bolts that are also supplied. Splice plates fit internally to the tray and are one-piece U shaped to fit into both adjoining pieces of cable tray.
3. **Other accessories** shall be furnished as required to protect, support, and install a cable tray system. Fittings shall be made of the same material as the cable tray whenever possible. Fittings can be of factory construction or may also be of a type that allows field constructed fittings.

F. LOADING CAPABILITIES

1. Cable tray shall meet the load/span class designation in accordance with NEMA VE 1 and CSA E22.2 No 126.1. Cable tray shall also meet load/span designation in accordance with IEC 61537.

G. DESIGN AND MANUFACTURE

1. Cable tray design shall be manufactured by The Niedax Group, series RLVX/RLCIX/RLX/RLUX/RSX/RSUX/RLCP-VX/RSVX series.

**Load/Span Class Designation in accordance
with NEMA VE 1 and CSA C22.2 No. 126.1**

Niedax Series	Minimum Area		Load class in accordance to NEMA VE 1		
	(calculational) mm ² / in. ²	in accordance to NEMA VE 2 mm ² / in. ²	Rated Load Kg/m / lb./ft.	Support spacing m / ft.	Load/Span Class
RSVX 50.050 S	112.5 / 0.17	-	60 / 40.3	2 / 6.6	-
RSVX 50.100 S	142.5 / 0.22	129 / 0.2	60 / 40.3	2 / 6.6	-



CABLE TRAY SYSTEM

Distribution Cable Tray

ventilated, with return flange

	Model no.	Height H		Width B		Thick-ness t	Length L		Weight per 100 m kg	Pack/Box Qty
		mm	Inch	mm	Inch		mm	Inch		
S	RSV 50.050	50	2	50	2	1,5	3000	118,1	127,02	2 x 3 m
F	RSV 50.050 F	50	2	50	2	1,5	3000	118,1	139,72	2 x 3 m
E3	RSV 50.050 E3	50	2	50	2	1,5	3000	118,1	127,83	2 x 3 m

bottom and side plates perforated with staggered punch holes
square punch holes of 30x65 mm (bottom) and of 20x65 mm (side rail) are provided for cable or pipe dropouts

Splice plates are not included. Please order two RVV 50 per joint.

Load Chart: q = uniformly distributed load (tested according to DIN EN IEC 61537 standard)

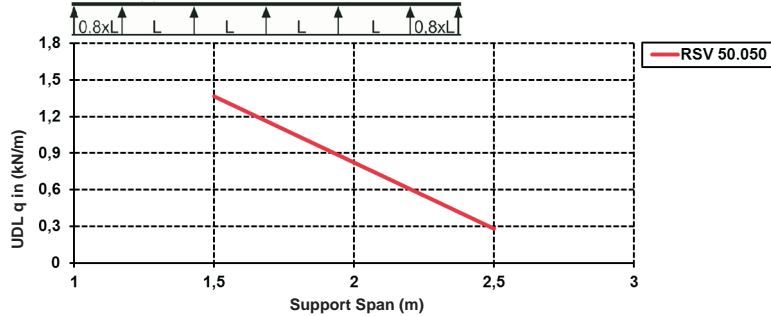

Height 50 mm
Nominal 2 inches

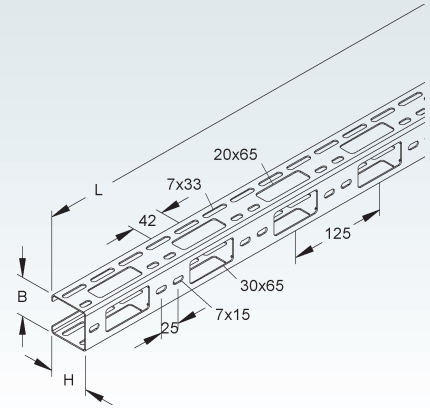
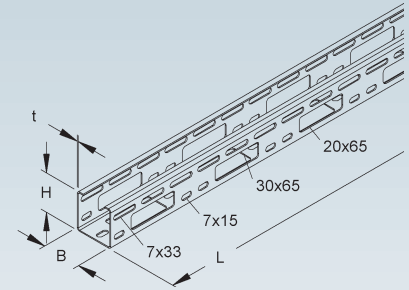

Distribution Cable Tray

ventilated, with return flange

	Model no.	Height H		Width B		Thick-ness t	Length L		Weight per 100 m kg	Pack/Box Qty
		mm	Inch	mm	Inch		mm	Inch		
S	RSV 50.100	50	2	100	3,9	1,5	3000	118,1	163,12	2 x 3 m
F	RSV 50.100 F	50	2	100	3,9	1,5	3000	118,1	179,43	2 x 3 m
E3	RSV 50.100 E3	50	2	100	3,9	1,5	3000	118,1	164,16	2 x 3 m

bottom and side plates perforated with staggered punch holes
square punch holes of 30x65 mm (bottom) and of 20x65 mm (side rail) are provided for cable or pipe dropouts

Splice plates are not included. Please order two RVV 50 per joint.

Load Chart: q = uniformly distributed load (tested according to DIN EN IEC 61537 standard)

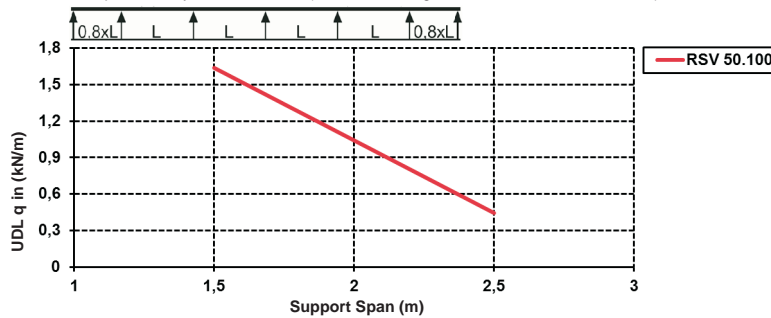

Height 50 mm
Nominal 2 inches

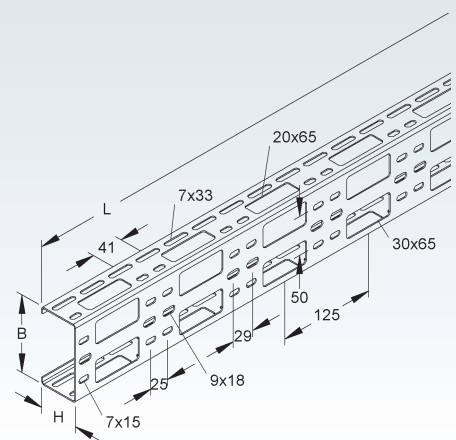
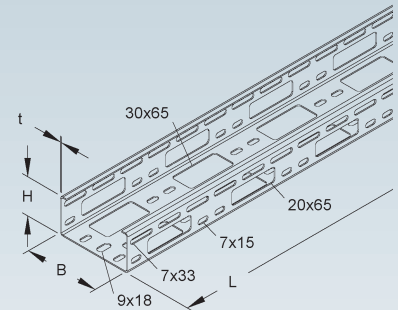

Edge Protection Ring

UV resistant

Model no.	Color	Inside height H		Inside dimension B		Weight per 100 pcs kg	Pack/Box Qty	
		mm	Inch	mm	Inch			
K04	KSR 20 A	black	14,5	0,6	58	2,3	0,32	20
K04	KSR 30 A	black	24,0	0,9	58	2,3	0,38	20

to protect cables at the knockouts

Suitable for: distribution cable trays RSV 50... and RLCI 60...

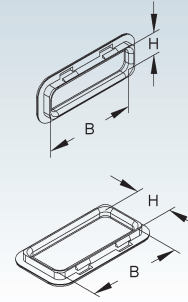

Divider

Model no.	Height H	Thickness t	Acc. incl.	Weight per 100 m kg	Pack/Box Qty		
						mm	Inch
S	RW 50	47	1,9	0,75	4 FLM 6X12	45,68	10 x 3 m
F	RW 50 F	47	1,9	0,75	4 FLM 6X12 F	50,14	10 x 3 m
E3	RW 50 E3	47	1,9	0,80	4 FLM 6X12 E3	48,88	10 x 3 m

to separate wires and cables of different voltage levels or with different functions

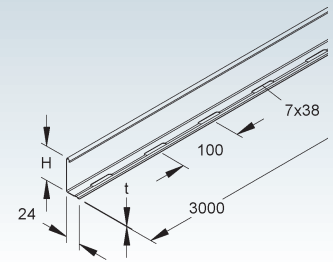
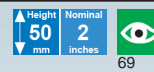

Splice Plate for Divider

Model no.	Height H	Length L	Weight per 100 pcs kg	Pack/Box Qty			
					mm	Inch	mm
E2	RTV 50 E2	46,5	1,8	80	3,1	1,18	20

for positive locking connections and proper bonding of dividers

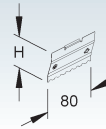

Cover for Distribution Cable Tray

with turnbolt locks

Model no.	Inside dimension B	Weight per 100 m kg	Pack/Box Qty		
				mm	Inch
S	RDSV 50	50	2	38,32	2 x 3 m
S	RDSV 100	100	3,9	68,17	2 x 3 m
F	RDSV 50 F	50	2	42,42	2 x 3 m
F	RDSV 100 F	100	3,9	75,52	2 x 3 m
E3	RDSV 50 E3	50	2	40,06	2 x 3 m
E3	RDSV 100 E3	100	3,9	73,58	2 x 3 m

Suitable for: distribution cable tray RSV 50... and RSV 100...

Please use turnbolt lock RDRS 2 for RDSV 100 covers and RDRS 2/50 for RDSV 50 covers.

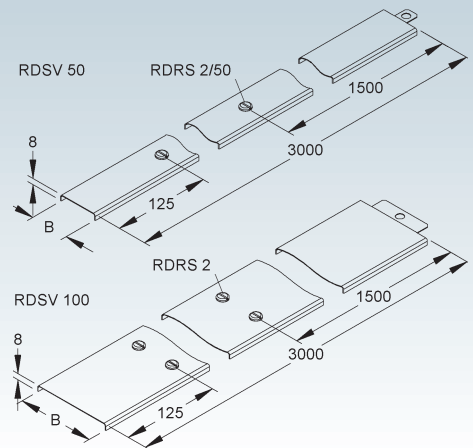

CABLE TRAY SYSTEM

Turnbolt Lock

incl. locking nut

Model no.	Acc. incl.	Weight per 100 pcs kg	Pack/Box Qty
S RDRS 2	1 FL 6X12-S V, 1 SMS 6 V	1,3	100
E3 RDRS 2 E3	1 FL 6X12-S E3, 1 SMS 6 E3	1,5	100

Suitable for: all R-series fitting covers and RSV 50.100 distribution tray covers

Please maintain a 50 mm minimum distance from the edge of the cover for the turn-bolt installation. Not sufficient for securing covers to tray installed vertically or sideways nor for securing covers against windloads. Please use self tapping screws, steel cable ties or coverhinges in addition.

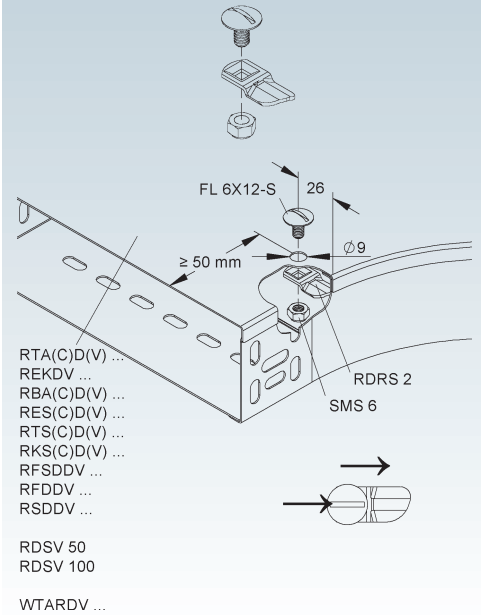

Turnbolt Lock

incl. locking nut

Model no.	Acc. incl.	Weight per 100 pcs kg	Pack/Box Qty
S RDRS 2/50	1 FL 6X12-S V, 1 SMS 6 V	1,3	100
E3 RDRS 2/50 E3	1 FL 6X12-S E3, 1 SMS 6 E3	1,5	100

Suitable for: RSV 50.050 distribution tray covers distribution cable tray covers and fittings in 50 mm width

Please maintain a 50 mm minimum distance from the edge of the cover for the turn-bolt installation. Not sufficient for securing covers to tray installed vertically or sideways nor for securing covers against windloads. Please use self tapping screws, steel cable ties or coverhinges in addition.

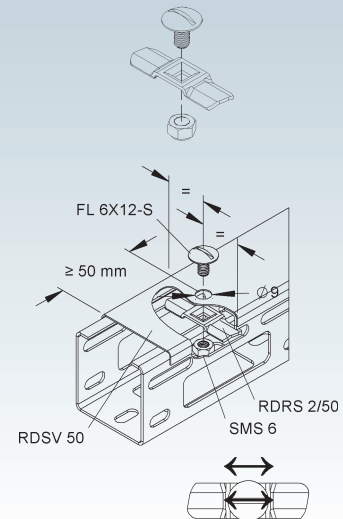

Universal Splice Plate

Model no.	Height H		Width B		Acc. incl.	Weight per 100 pcs kg	Pack/Box Qty
	mm	Inch	mm	Inch			
S RVV 50	44	1,7	135	5,3	4 FLM 6X12	8,70	20
F RVV 50 F	44	1,7	135	5,3	4 FLM 6X12 F	8,69	20
E3 RVV 50 E3	44	1,7	135	5,3	4 FLM 6X12 E3	8,77	20

for straight and angled joints

2 pieces required per joint

Height 50 mm
Nominal 2 inches

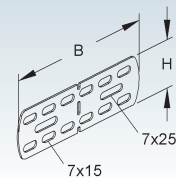

Extension Horizontal Tee

Model no.	Height H mm Inch	Inside dimension B mm Inch	Acc. incl.	Weight per 100 pcs kg	Pack/Box Qty
S RTAK 50.050	50 2	52 2	2 FLM 6X12	25,02	1
S RTAK 50.100	50 2	102 4	2 FLM 6X12	29,73	1

Suitable for: mini cable tray RL 50.050 and distribution cable trays RSV 50...

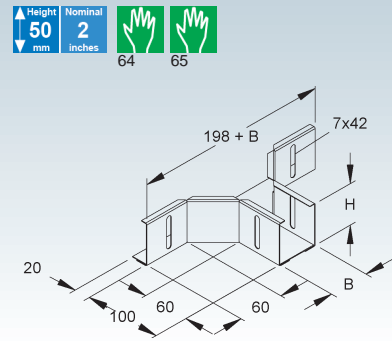

Cover for Horizontal Extension Tee

with turnbolt locks

Model no.	Inside dimension B mm Inch	Weight per 100 pcs kg	Pack/Box Qty
S RTAKDV 50	54 2,1	12,45	1
S RTAKDV 100	104 4,1	17,00	1

Suitable for: horizontal extension tee RTAK...

Hot-dip galvanized covers can be special ordered.

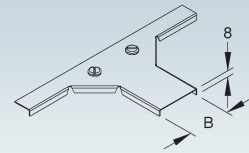

Horizontal Elbow 90°

Model no.	Height H mm Inch	Inside dimension B mm Inch	Acc. incl.	Weight per 100 pcs kg	Pack/Box Qty
S RESK 50.050	50 2	52 2	2 FLM 6X12	32,23	1
S RESK 50.100	50 2	102 4	2 FLM 6X12	50,45	1

Suitable for: mini cable tray RL 50.050 and distribution cable trays RSV 50...

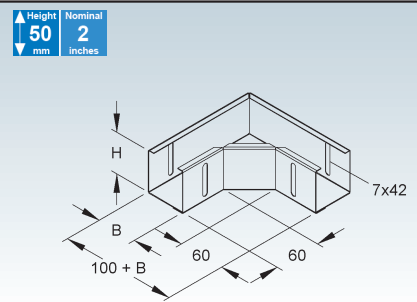

Cover for 90° Horizontal Elbow

with turnbolt locks

Model no.	Inside dimension B mm Inch	Weight per 100 pcs kg	Pack/Box Qty
S RESKDV 50	54 2,1	15,05	1
S RESKDV 100	104 4,1	32,00	1

Suitable for: horizontal 90° elbow RESK...

Hot-dip galvanized covers can be special ordered.

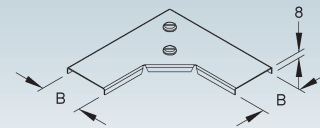

Horizontal Tee

Model no.	Height H mm Inch	Inside dimension B mm Inch	Acc. incl.	Weight per 100 pcs kg	Pack/Box Qty
S RTSK 50.050	50 2	52 2	4 FLM 6X12	43,74	1
S RTSK 50.100	50 2	102 4	4 FLM 6X12	63,62	1

Suitable for: mini cable tray RL 50.050 and distribution cable trays RSV 50...

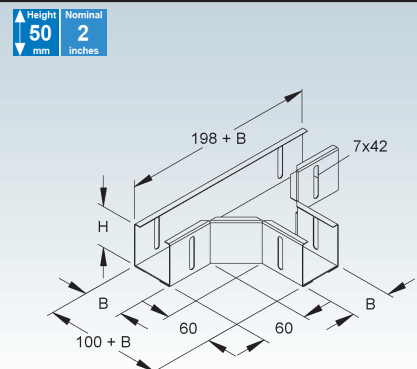

CABLE TRAY SYSTEM

Cover for Horizontal Tee

with turnbolt locks

	Model no.	Inside dimension B mm Inch	Weight per 100 pcs kg	Pack/Box Qty
S	RTSKDV 50	54 2,1	20,37	1
S	RTSKDV 100	104 4,1	39,04	1

Suitable for: horizontal tee RTSK...

Hot-dip galvanized covers can be special ordered.

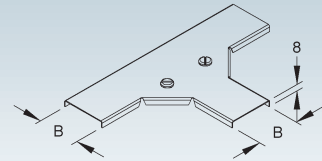

Raised Cover Clamp

spacer block with hold down bracket

	Model no.	Height H mm Inch	Width B mm Inch	Thick-ness t mm	Acc. incl.	Weight per 100 pcs kg	Pack/Box Qty
S	RAHA 30 S	122,5 4,8	40 1,6	1,5	2 FLM 6X12, 2 FLM 8X16 F	16,32	10
E3	RAHA 30 E3	122,5 4,8	40 1,6	1,5	2 FLM 6X12 E3, 2 FLM 8X16 E3	16,22	10

to elevate RD- and WDV-series covers for improved ventilation can be installed on all R-Series cable trays and all KL/WSL/WRL-series cable ladders with a minimum side rail height of 50 mm

Three pairs required for every 3-meter section of covers.

Suitable for: ventilated RL/RS cable trays, KL ladders, and WRL/WSL cable trays & ladders

Six cover clamps are required for any 3-meter piece of cover.

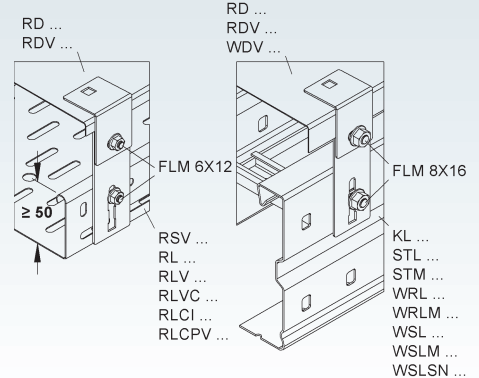
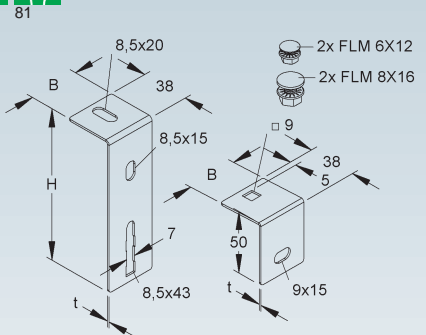

NOTES

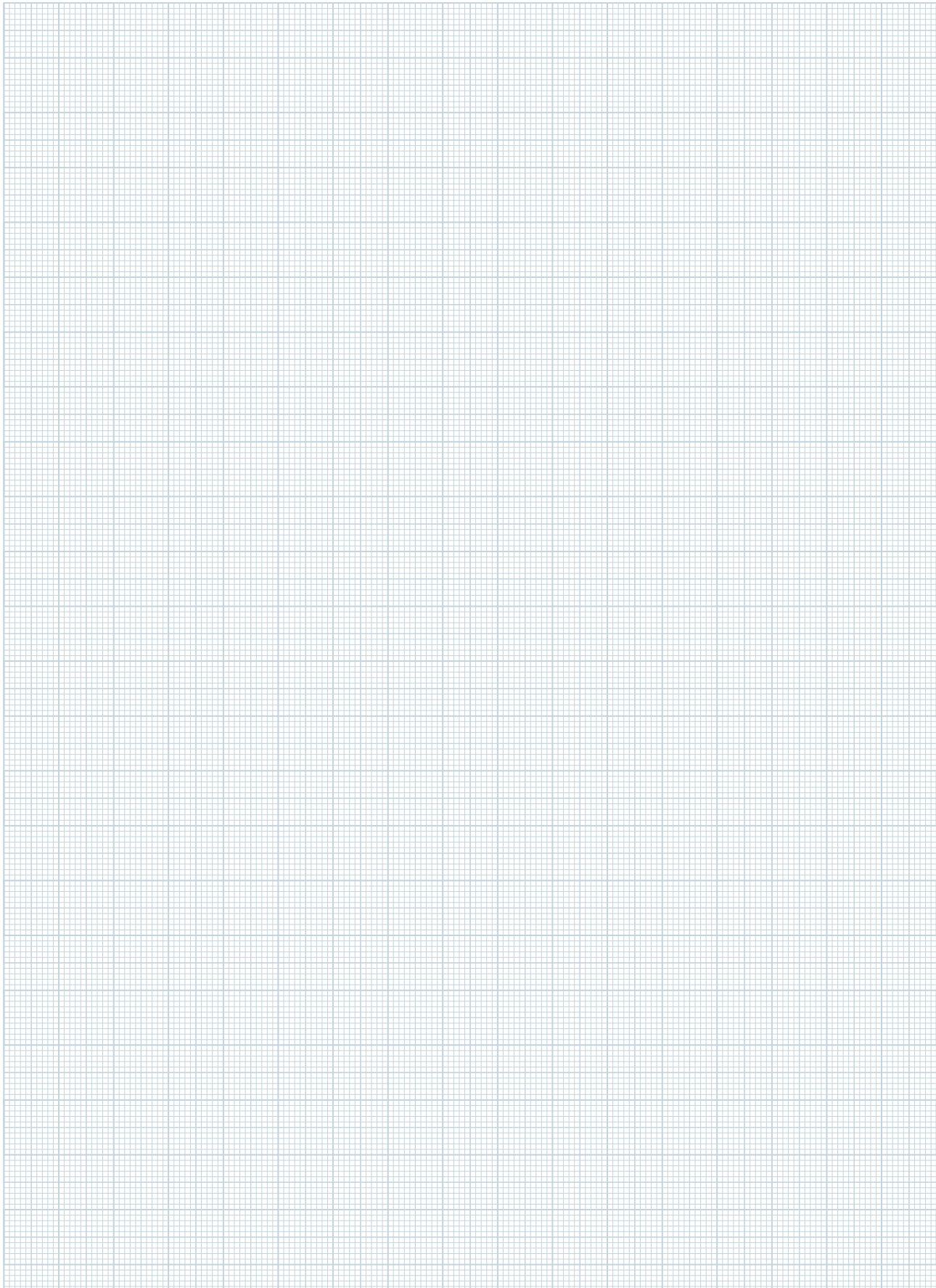

CABLE TRAY SYSTEM

Available Side Rail Heights

SYSTEM	Distribution Cable Tray	RLCI...	Page 193
	Cable Tray	RL...	Page 194
	Cable Tray	RLU...	Page 194
	Heavy Duty Cable Tray	RS...	Page 195
	Heavy Duty Cable Tray	RSU...	Page 195
ACCESSORIES	Boltless Splice Plate	RVC 60	Page 193
	Bottom Connection Plate	RSLC...	Page 193
	Edge Protection Ring	KSR 30 A	Page 194
	U-shaped Splice Plate	RV...	Page 196
	Universal Splice Plate	RVV 50...	Page 196
	Universal Splice Plate	RSUV 60-1.5/200 S	Page 196
	Divider	RW...	Page 196
	Splice Plate for Divider	RTV 60 E2	Page 197
	Mounting Plate for Divider	RTPH 50...	Page 197
	Extension Horizontal Tee	RTA...	Page 198
	Horizontal Elbow Building Block	REK...	Page 198
	Flexible Horizontal Elbow 0-90°	RBAV...	Page 198
	Horizontal Elbow 45°	RBA...	Page 199
	Horizontal Elbow 90°	RES...	Page 199
	Horizontal Tee	RTS...	Page 199
	Horizontal Cross	RKS...	Page 200
	Reducer/Blind End	RA...	Page 200
	Adjustable Horizontal Splice/Reducer/Blind End	RAW...	Page 200
	Adjustable Vertical Splice Plate	RGV...	Page 200
	Splice/Link Kit	RGE...	Page 201
	Vertical Inside Elbow 90°	RSD...	Page 201
	Vertical Outside Elbow 90°	RFD...	Page 201
	Vertical Tee Down, lengthwise	RTL...	Page 202
	Vertical Tee Down, crosswise	RTQ...	Page 202
	Edge Protection Plate	RKB...	Page 202

See covers for cable trays and fittings on page 229 and following.



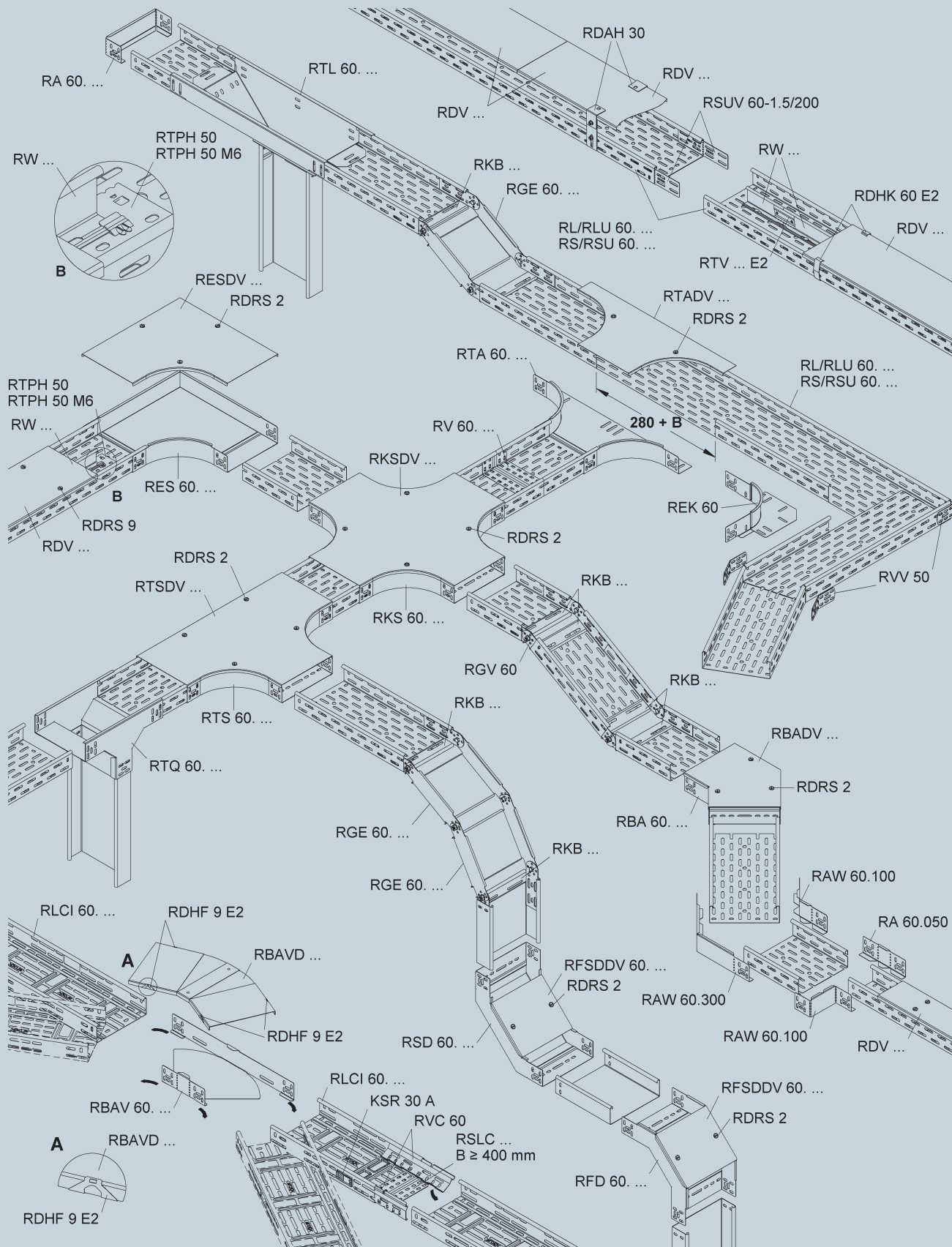

CABLE TRAY SYSTEM

Load/Span Class Designation in accordance with NEMA VE 1 and CSA C22.2 No. 126.1

Niedax Series	Minimum Area		Load class in accordance to NEMA VE 1		
	(calculational) mm ² / in. ²	in accordance to NEMA VE 2 mm ² / in. ²	Rated Load Kg/m / lb./ft.	Support spacing m / ft.	Load/Span Class
RLCIX 60.100 S	152 / 0.24	129 / 0.2	37 / 25	2,4 / 8	8AA
RLCIX 60.200 S	163 / 0.25	129 / 0.2	37 / 25	2,4 / 8	8AA
RLCIX 60.300 S	232 / 0.36	129 / 0.2	37 / 25	2,4 / 8	8AA
RLX 60.100	169 / 0.26	129 / 0.2	93 / 62.5	2 / 6.6	5A, A
RLX 60.150	202 / 0.31	129 / 0.2	93 / 62.5	2 / 6.6	5A, A
RLX 60.200	234 / 0.36	129 / 0.2	93 / 62.5	2 / 6.6	5A, A
RLUX 60.100	220 / 0.34	129 / 0.2	93 / 62.5	2 / 6.6	5A, A
RLUX 60.150	265 / 0.41	258 / 0.4	93 / 62.5	2 / 6.6	5A, A
RLUX 60.200	310 / 0.48	258 / 0.4	93 / 62.5	2 / 6.6	5A, A
RLUX 60.100 E3	195 / 0.30	129 / 0.2	93 / 62.5	2 / 6.6	5A, A
RLUX 60.200 E3	275 / 0.43	258 / 0.4	93 / 62.5	2 / 6.6	5A, A
RSX 60.100, ... F	278 / 0.43	258 / 0.4	173 / 116.3	2 / 6.6	5A, C
RSX 60.200, ... F	386 / 0.60	258 / 0.4	173 / 116.3	2 / 6.6	5A, C
RSX 60.300, ... F	494 / 0.77	452 / 0.7	173 / 116.3	2 / 6.6	5A, C
RSX 60.400, ... F	602 / 0.93	452 / 0.7	173 / 116.3	2 / 6.6	5A, C
RSX 60.500, ... F	710 / 1.10	645 / 1.0	173 / 116.3	2 / 6.6	5A, C
RSX 60.600, ... F	818 / 1.27	645 / 1.0	173 / 116.3	2 / 6.6	5A, C
RSUX 60.100, ... F	362 / 0.56	258 / 0.4	173 / 116.3	2 / 6.6	5A, C
RSUX 60.200, ... F	512 / 0.79	452 / 0.7	173 / 116.3	2 / 6.6	5A, C
RSUX 60.300, ... F	662 / 1.03	645 / 1.0	173 / 116.3	2 / 6.6	5A, C
RSUX 60.400, ... F	812 / 1.26	645 / 1.0	173 / 116.3	2 / 6.6	5A, C
RSUX 60.500, ... F	962 / 1.49	645 / 1.0	173 / 116.3	2 / 6.6	5A, C
RSUX 60.600, ... F	1112 / 1.72	968 / 1.5	173 / 116.3	2 / 6.6	5A, C



Distribution Cable Tray

	Model no.	Height H		Width B		Thick-ness t mm	Weight per 100 m kg	Pack/Box Qty
		mm	Inch	mm	Inch			
S	RLCI 60.100 S	60	2,4	100	3,9	0,9	140,46	2 x 3 m
S	RLCI 60.200 S	60	2,4	200	7,9	0,9	195,54	2 x 3 m
S	RLCI 60.300 S	60	2,4	300	11,8	1,0	272,34	2 x 3 m

designed for installation under sprinkler systems

Two RVC 60 splice plates included with every piece of cable tray.

Load Chart: q = uniformly distributed load (tested according to DIN EN IEC 61537 standard)

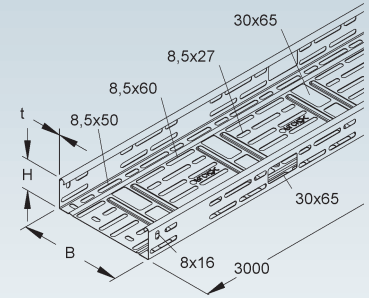
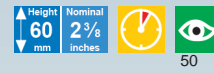
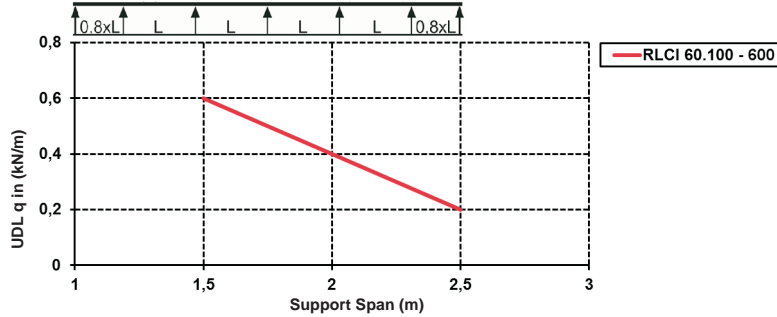

Boltless Splice Plate

	Model no.	Height H		Weight per 100 pcs kg	Pack/Box Qty
		mm	Inch		
S	RVC 60	60	2,4	16,96	50

2 pieces required per joint

Suitable for: cable tray RLCI 60...

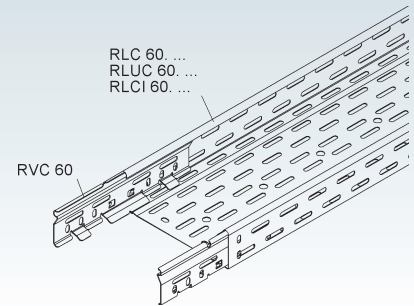
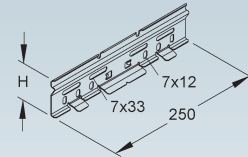

Bottom Connection Plate

	Model no.	Width B		Acc. incl.	Weight per 100 pcs kg	Pack/Box Qty
		mm	Inch			
S	RSLC 100	41,5	1,6	4 FLM 6X12	5,93	10
S	RSLC 200	139,0	5,5	4 FLM 6X12	12,67	10
S	RSLC 300	239,0	9,4	4 FLM 6X12	19,61	10

for stabilizing the bottom plate of cable trays

Suitable for: cable trays RLCI 60... und RLCPV 85...

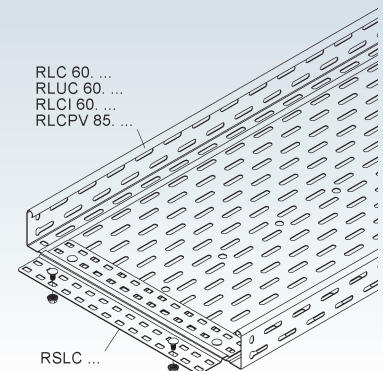
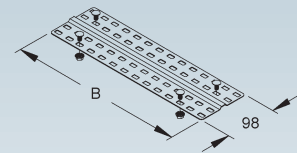

CABLE TRAY SYSTEM

Edge Protection Ring

UV resistant

Model no.	Color	Inside height H mm Inch	Inside dimension B mm Inch	Weight per 100 pcs kg	Pack/Box Qty
K04 KSR 30 A	black	24 0,9	58 2,3	0,38	20

to protect cables at the knockouts

Suitable for: distribution cable trays RSV 50... and RLCI 60...

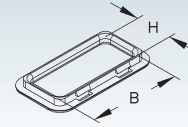

Cable Tray

ventilated

Model no.	Height H mm Inch	Width B mm Inch	Thickness t mm	Acc. incl.	Weight per 100 m kg	Pack/Box Qty
S RL 60.100	60 2,4	100 3,9	0,9	8 FLM 6X12	155,04	2 x 3 m
S RL 60.150	60 2,4	150 5,9	0,9	8 FLM 6X12	185,54	2 x 3 m
S RL 60.200	60 2,4	200 7,9	0,9	8 FLM 6X12	216,03	2 x 3 m

Centered punchholes allow hanging with M10 (3/8") threaded rod. Bottom plate and side rail perforated with staggered punch holes.

One RV... splice plate included with every piece of cable tray.

Load Chart: q = uniformly distributed load (tested according to DIN EN IEC 61537 standard)

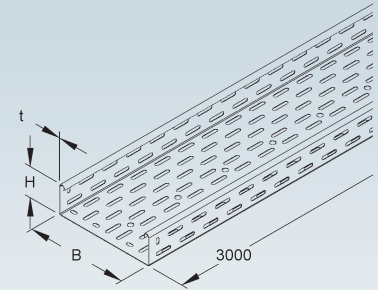
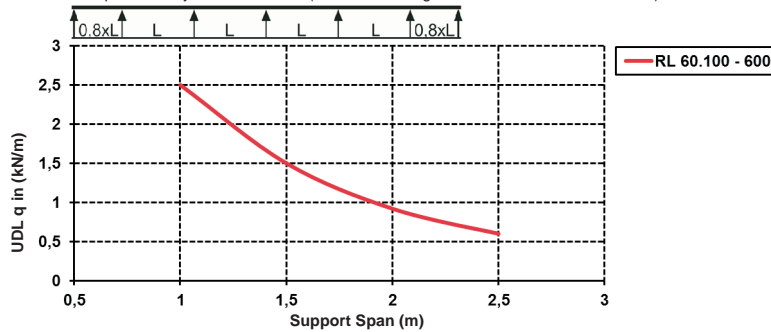

Cable Tray

solid, but with splice plate perforation

Model no.	Height H mm Inch	Width B mm Inch	Thickness t mm	Acc. incl.	Weight per 100 m kg	Pack/Box Qty
S RLU 60.100	60 2,4	100 3,9	0,9	8 FLM 6X12	178,93	2 x 3 m
S RLU 60.150	60 2,4	150 5,9	0,9	8 FLM 6X12	215,28	2 x 3 m
S RLU 60.200	60 2,4	200 7,9	0,9	8 FLM 6X12	251,62	2 x 3 m
E3 RLU 60.100 E3	60 2,4	100 3,9	0,8	8 FLM 6X12 E3	161,18	2 x 3 m
E3 RLU 60.200 E3	60 2,4	200 7,9	0,8	8 FLM 6X12 E3	226,44	2 x 3 m

One RV... splice plate included with every piece of cable tray.

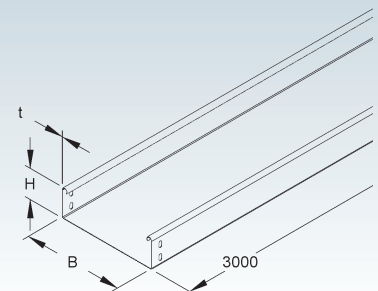

Heavy Duty Cable Tray

ventilated

	Model no.	Height H		Width B		Thick-ness t	Acc. incl.	Weight per 100 m kg	Pack/Box Qty
		mm Inch	mm Inch	mm	mm				
S	RS 60.100	60 2,4	100 3,9	1,5	8 FLM 6X12	250,01	2 x 3 m		
S	RS 60.200	60 2,4	200 7,9	1,5	8 FLM 6X12	350,29	2 x 3 m		
S	RS 60.300	60 2,4	300 11,8	1,5	10 FLM 6X12	451,10	2 x 3 m		
S	RS 60.400	60 2,4	400 15,7	1,5	12 FLM 6X12	551,91	2 x 3 m		
S	RS 60.500	60 2,4	500 19,7	1,5	12 FLM 6X12	652,20	2 x 3 m		
S	RS 60.600	60 2,4	600 23,6	1,5	12 FLM 6X12	752,48	2 x 3 m		
F	RS 60.100 F	60 2,4	100 3,9	1,5	8 FLM 6X12 F	274,80	2 x 3 m		
F	RS 60.200 F	60 2,4	200 7,9	1,5	8 FLM 6X12 F	385,11	2 x 3 m		
F	RS 60.300 F	60 2,4	300 11,8	1,5	10 FLM 6X12 F	495,95	2 x 3 m		
F	RS 60.400 F	60 2,4	400 15,7	1,5	12 FLM 6X12 F	606,79	2 x 3 m		
F	RS 60.500 F	60 2,4	500 19,7	1,5	12 FLM 6X12 F	717,10	2 x 3 m		
F	RS 60.600 F	60 2,4	600 23,6	1,5	12 FLM 6X12 F	827,42	2 x 3 m		

Bottom plate and side rail perforated with staggered punch holes.
Centered punchholes allow hanging with M10 (3/8") threaded rod.

One RV... splice plate included with every piece of cable tray.

Load Chart: q = uniformly distributed load (tested according to DIN EN IEC 61537 standard)

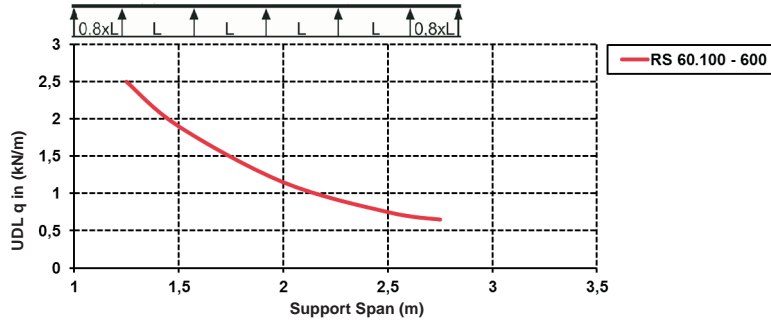

Height 60 mm
Nominal 2 3/8 inches

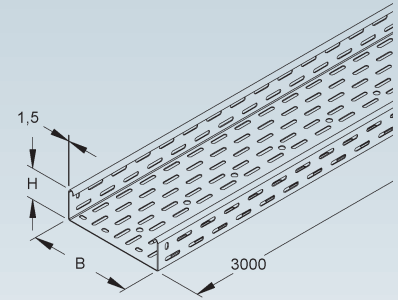

Heavy Duty Cable Tray

solid, but with splice plate perforation

	Model no.	Height H		Width B		Thick-ness t	Acc. incl.	Weight per 100 m kg	Pack/Box Qty
		mm Inch	mm Inch	mm	mm				
S	RSU 60.100	60 2,4	100 3,9	1,5	8 FLM 6X12	289,82	2 x 3 m		
S	RSU 60.200	60 2,4	200 7,9	1,5	8 FLM 6X12	409,62	2 x 3 m		
S	RSU 60.300	60 2,4	300 11,8	1,5	10 FLM 6X12	529,88	2 x 3 m		
S	RSU 60.400	60 2,4	400 15,7	1,5	12 FLM 6X12	650,14	2 x 3 m		
S	RSU 60.500	60 2,4	500 19,7	1,5	12 FLM 6X12	769,93	2 x 3 m		
S	RSU 60.600	60 2,4	600 23,6	1,5	12 FLM 6X12	889,73	2 x 3 m		
F	RSU 60.100 F	60 2,4	100 3,9	1,5	8 FLM 6X12 F	318,55	2 x 3 m		
F	RSU 60.200 F	60 2,4	200 7,9	1,5	8 FLM 6X12 F	450,33	2 x 3 m		
F	RSU 60.300 F	60 2,4	300 11,8	1,5	10 FLM 6X12 F	582,60	2 x 3 m		
F	RSU 60.400 F	60 2,4	400 15,7	1,5	12 FLM 6X12 F	714,79	2 x 3 m		
F	RSU 60.500 F	60 2,4	500 19,7	1,5	12 FLM 6X12 F	846,57	2 x 3 m		
F	RSU 60.600 F	60 2,4	600 23,6	1,5	12 FLM 6X12 F	978,34	2 x 3 m		

One RV... splice plate included with every piece of cable tray.

Height 60 mm
Nominal 2 3/8 inches

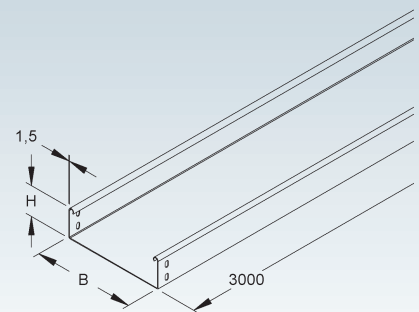

CABLE TRAY SYSTEM

U-Shaped Splice Plate

	Model no.	Height H		Width B		Acc. incl.	Weight per 100 pcs kg	Pack/Box Qty
		mm	Inch	mm	Inch			
S	RV 60.100	49	1,9	96	3,8	8 FLM 6X12	17,63	1
S	RV 60.150	49	1,9	146	5,7	8 FLM 6X12	20,70	1
S	RV 60.200	49	1,9	196	7,7	8 FLM 6X12	23,77	1
S	RV 60.300	49	1,9	296	11,7	10 FLM 6X12	31,48	1
S	RV 60.400	49	1,9	396	15,6	12 FLM 6X12	39,20	1
S	RV 60.500	49	1,9	496	19,5	12 FLM 6X12	45,34	1
S	RV 60.600	49	1,9	596	23,5	12 FLM 6X12	51,47	1
F	RV 60.100 F	49	1,9	96	3,8	8 FLM 6X12 F	18,76	1
F	RV 60.200 F	49	1,9	196	7,7	8 FLM 6X12 F	25,51	1
F	RV 60.300 F	49	1,9	296	11,7	10 FLM 6X12 F	33,84	1
F	RV 60.400 F	49	1,9	396	15,6	12 FLM 6X12 F	42,17	1
F	RV 60.500 F	49	1,9	496	19,5	12 FLM 6X12 F	48,93	1
F	RV 60.600 F	49	1,9	596	23,5	12 FLM 6X12 F	55,67	1
E3	RV 60.100 E3	49	1,9	96	3,8	8 FLM 6X12 E3	17,93	1
E3	RV 60.200 E3	49	1,9	196	7,7	8 FLM 6X12 E3	24,11	1
E3	RV 60.300 E3	49	1,9	296	11,7	10 FLM 6X12 E3	31,92	1
E3	RV 60.400 E3	49	1,9	396	15,6	12 FLM 6X12 E3	39,74	1
E3	RV 60.500 E3	49	1,9	496	19,5	12 FLM 6X12 E3	45,91	1
E3	RV 60.600 E3	49	1,9	596	23,5	12 FLM 6X12 E3	52,09	1

Suitable for: cable trays RL..., RLU..., RS... and RSU...

Height 60 mm
Nominal 2 3/8 inches

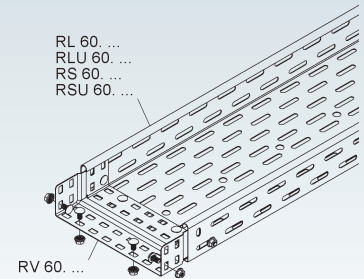
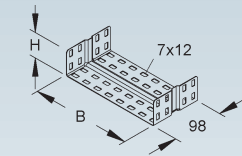

Universal Splice Plate

	Model no.	Height H		Width B		Acc. incl.	Weight per 100 pcs kg	Pack/Box Qty
		mm	Inch	mm	Inch			
S	RVV 50	44	1,7	135	5,3	4 FLM 6X12	8,70	20
F	RVV 50 F	44	1,7	135	5,3	4 FLM 6X12 F	8,69	20
E3	RVV 50 E3	44	1,7	135	5,3	4 FLM 6X12 E3	8,77	20

for straight and angled joints

2 pieces required per joint

Height 50 mm
Nominal 2 inches

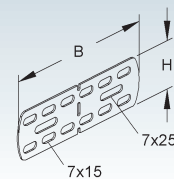

Universal Splice Plate

	Model no.	Height H		Width B		Thickness t	Acc. incl.	Weight per 100 pcs kg	Pack/Box Qty
		mm	Inch	mm	Inch				
S	RSUV 60-1.5/200 S	51	2	200	7,9	1,5	4 FLM 6X12	12,93	50

for straight and angled joints

2 pieces required per joint

Height 60 mm
Nominal 2 3/8 inches

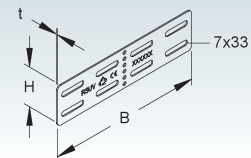

Divider

	Model no.	Height H		Thickness t	Acc. incl.	Weight per 100 m kg	Pack/Box Qty
		mm	Inch				
S	RW 60	55	2,2	0,75	4 FLM 6X12	50,42	10 x 3 m
F	RW 60 F	55	2,2	0,75	4 FLM 6X12 F	55,36	10 x 3 m
E3	RW 60 E3	55	2,2	0,80	4 FLM 6X12 E3	53,97	10 x 3 m

to separate wires and cables of different voltage levels or with different functions

Height 60 mm
Nominal 2 3/8 inches

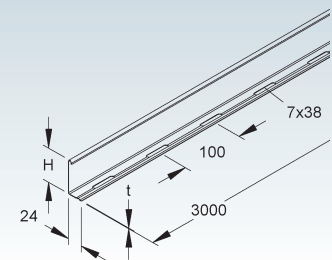

Splice Plate for Divider

Model no.	Height H	Length L	Weight per 100 pcs kg	Pack/ Box Qty
	mm Inch	mm Inch		
E2 RTV 60 E2	54,5 2,1	80 3,1	1,39	20

for positive locking connections and proper bonding of dividers

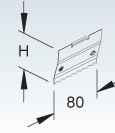

Mounting Plate for Divider

Model no.	Length L	Width B	Thick- ness t	Weight per 100 pcs kg	Pack/ Box Qty
	mm Inch	mm Inch	mm		
S RTPH 50	83 3,3	59 2,3	0,9	3,36	20

Mounting plate with locking mechanism for fast installation of dividers in ventilated cable tray series RL.../RS... series (min. width 100 mm) and ventilated cable trays series RLCI 60... / RLCPV 85... (min. width 200 mm).

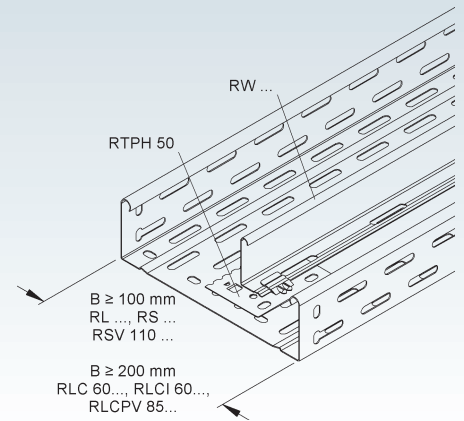
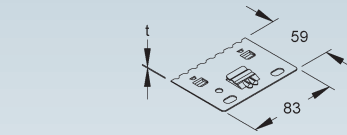

Mounting Plate for Divider with M6 Stud

Model no.	Length L	Width B	Thick- ness t	Acc. incl.	Weight per 100 pcs kg	Pack/ Box Qty
	mm Inch	mm Inch	mm			
S RTPH 50 M6	83 3,3	59 2,3	0,9	1 SMF6	3,98	50

Mounting plate with locking mechanism for fast installation of dividers in ventilated cable tray series RL.../RS... series (min. width 100 mm) and ventilated cable trays series RLCI 60... / RLCPV 85... (min. width 200 mm). With M6 locking stud.

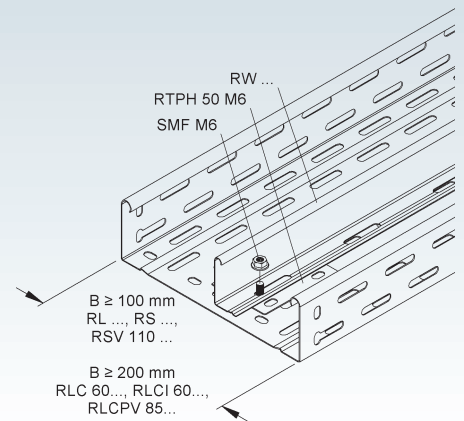
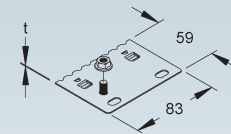

CABLE TRAY SYSTEM

Extension Horizontal Tee

with integrated splice

	Model no.	Height H		Inside dimension B		Acc. incl.	Weight per 100 pcs kg	Pack/Box Qty
		mm	Inch	mm	Inch			
S	RTA 60.100	60	2,4	102	4	10 FLM 6X12	79,21	1
S	RTA 60.150	60	2,4	152	6	10 FLM 6X12	86,50	1
S	RTA 60.200	60	2,4	202	8	10 FLM 6X12	95,01	1
S	RTA 60.300	60	2,4	302	11,9	10 FLM 6X12	113,06	1
S	RTA 60.400	60	2,4	402	15,8	10 FLM 6X12	129,10	1
S	RTA 60.500	60	2,4	502	19,8	10 FLM 6X12	145,50	1
S	RTA 60.600	60	2,4	602	23,7	10 FLM 6X12	162,40	1
F	RTA 60.100 F	60	2,4	102	4	10 FLM 6X12 F	85,00	1
F	RTA 60.150 F	60	2,4	152	6	10 FLM 6X12 F	94,40	1
F	RTA 60.200 F	60	2,4	202	8	10 FLM 6X12 F	104,63	1
F	RTA 60.300 F	60	2,4	302	11,9	10 FLM 6X12 F	122,30	1
F	RTA 60.400 F	60	2,4	402	15,8	10 FLM 6X12 F	141,20	1
F	RTA 60.500 F	60	2,4	502	19,8	10 FLM 6X12 F	159,30	1
F	RTA 60.600 F	60	2,4	602	23,7	10 FLM 6X12 F	177,80	1
E3	RTA 60.100 E3	60	2,4	102	4	10 FLM 6X12 E3	72,09	1
E3	RTA 60.200 E3	60	2,4	202	8	10 FLM 6X12 E3	87,18	1
E3	RTA 60.300 E3	60	2,4	302	11,9	10 FLM 6X12 E3	102,31	1
E3	RTA 60.400 E3	60	2,4	402	15,8	10 FLM 6X12 E3	136,98	1
E3	RTA 60.500 E3	60	2,4	502	19,8	10 FLM 6X12 E3	155,46	1
E3	RTA 60.600 E3	60	2,4	602	23,7	10 FLM 6X12 E3	174,38	1

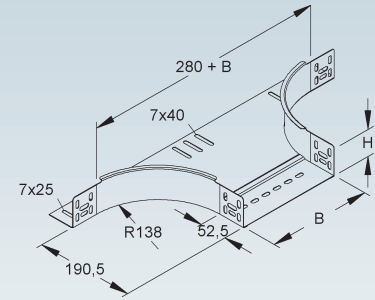
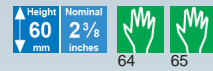

Horizontal Elbow Building Block

with integrated splice

	Model no.	Height H		Acc. incl.	Weight per 100 pcs kg	Pack/Box Qty
		mm	Inch			
S	REK 60	60	2,4	6 FLM 6X12	30,89	10
F	REK 60 F	60	2,4	6 FLM 6X12 F	33,51	10
E3	REK 60 E3	60	2,4	6 FLM 6X12 E3	30,66	10

for building customized horizontal cable tray fittings

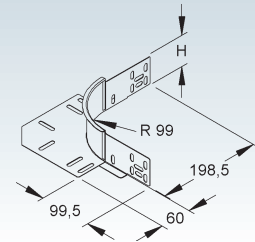
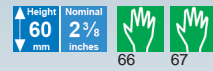

Flexible Horizontal Elbow 0-90°

with integrated splice

	Model no.	Height H		Inside dimension B		Acc. incl.	Weight per 100 pcs kg	Pack/Box Qty
		mm	Inch	mm	Inch			
S	RBAV 60.100	60	2,4	100	3,9	10 FLM 6X12	44,11	1
S	RBAV 60.150	60	2,4	150	5,9	10 FLM 6X12	58,15	1
S	RBAV 60.200	60	2,4	200	7,9	10 FLM 6X12	73,71	1
S	RBAV 60.300	60	2,4	300	11,8	10 FLM 6X12	115,39	1
S	RBAV 60.400	60	2,4	400	15,7	10 FLM 6X12	167,07	1
S	RBAV 60.500	60	2,4	500	19,7	14 FLM 6X12	237,47	1
S	RBAV 60.600	60	2,4	600	23,6	14 FLM 6X12	315,84	1

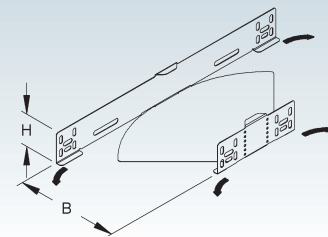
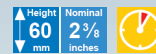

Horizontal Elbow 45°

with integrated splice

Model no.		Height H	Inside dimension B	Acc. incl.	Weight per 100 pcs kg	Pack/Box Qty
		mm Inch	mm Inch			
S	RBA 60.100	60 2,4	102 4	4 FLM 6X12	42,90	1
S	RBA 60.150	60 2,4	152 6	4 FLM 6X12	59,98	1
S	RBA 60.200	60 2,4	202 8	5 FLM 6X12	75,88	1
S	RBA 60.300	60 2,4	302 11,9	5 FLM 6X12	109,10	1
S	RBA 60.400	60 2,4	402 15,8	6 FLM 6X12	152,10	1
S	RBA 60.500	60 2,4	502 19,8	6 FLM 6X12	205,43	1
S	RBA 60.600	60 2,4	602 23,7	6 FLM 6X12	260,46	1
F	RBA 60.100 F	60 2,4	102 4	4 FLM 6X12 F	50,14	1
F	RBA 60.150 F	60 2,4	152 6	4 FLM 6X12 F	46,00	1
F	RBA 60.200 F	60 2,4	202 8	5 FLM 6X12 F	83,61	1
F	RBA 60.300 F	60 2,4	302 11,9	5 FLM 6X12 F	122,81	1
F	RBA 60.400 F	60 2,4	402 15,8	6 FLM 6X12 F	163,60	1
F	RBA 60.500 F	60 2,4	502 19,8	6 FLM 6X12 F	216,60	1
F	RBA 60.600 F	60 2,4	602 23,7	6 FLM 6X12 F	276,80	1

Height 60 mm
Nominal 2 3/8 inches

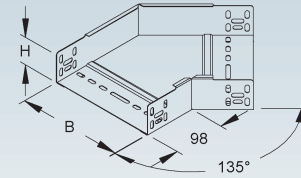

Horizontal Elbow 90°

with integrated splice

Model no.		Height H	Inside dimension B	Acc. incl.	Weight per 100 pcs kg	Pack/Box Qty
		mm Inch	mm Inch			
S	RES 60.100	60 2,4	102 4	4 FLM 6X12	90,36	1
S	RES 60.150	60 2,4	152 6	4 FLM 6X12	118,51	1
S	RES 60.200	60 2,4	202 8	5 FLM 6X12	160,44	1
S	RES 60.300	60 2,4	302 11,9	5 FLM 6X12	241,31	1
S	RES 60.400	60 2,4	402 15,8	6 FLM 6X12	338,24	1
S	RES 60.500	60 2,4	502 19,8	6 FLM 6X12	450,50	1
S	RES 60.600	60 2,4	602 23,7	6 FLM 6X12	578,46	1
F	RES 60.100 F	60 2,4	102 4	4 FLM 6X12 F	99,42	1
F	RES 60.150 F	60 2,4	152 6	4 FLM 6X12 F	125,00	1
F	RES 60.200 F	60 2,4	202 8	5 FLM 6X12 F	176,54	1
F	RES 60.300 F	60 2,4	302 11,9	5 FLM 6X12 F	265,49	1
F	RES 60.400 F	60 2,4	402 15,8	6 FLM 6X12 F	358,90	1
F	RES 60.500 F	60 2,4	502 19,8	6 FLM 6X12 F	479,50	1
F	RES 60.600 F	60 2,4	602 23,7	6 FLM 6X12 F	617,10	1
E3	RES 60.100 E3	60 2,4	102 4	4 FLM 6X12 E3	81,67	1
E3	RES 60.200 E3	60 2,4	202 8	5 FLM 6X12 E3	136,10	1
E3	RES 60.300 E3	60 2,4	302 11,9	5 FLM 6X12 E3	202,25	1
E3	RES 60.400 E3	60 2,4	402 15,8	6 FLM 6X12 E3	281,62	1
E3	RES 60.500 E3	60 2,4	502 19,8	6 FLM 6X12 E3	373,05	1
E3	RES 60.600 E3	60 2,4	602 23,7	6 FLM 6X12 E3	477,11	1

Height 60 mm
Nominal 2 3/8 inches

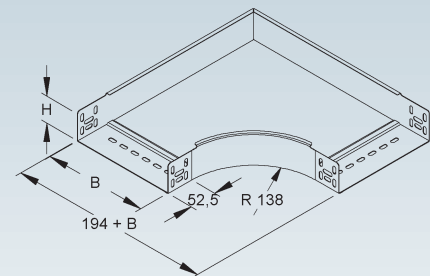

Horizontal Tee

with integrated splice

Model no.		Height H	Inside dimension B	Acc. incl.	Weight per 100 pcs kg	Pack/Box Qty
		mm Inch	mm Inch			
S	RTS 60.100	60 2,4	102 4	8 FLM 6X12	115,40	1
S	RTS 60.150	60 2,4	152 6	8 FLM 6X12	147,20	1
S	RTS 60.200	60 2,4	202 8	10 FLM 6X12	195,40	1
S	RTS 60.300	60 2,4	302 11,9	12 FLM 6X12	294,05	1
S	RTS 60.400	60 2,4	402 15,8	12 FLM 6X12	399,68	1
S	RTS 60.500	60 2,4	502 19,8	12 FLM 6X12	520,95	1
S	RTS 60.600	60 2,4	602 23,7	12 FLM 6X12	657,87	1
F	RTS 60.100 F	60 2,4	102 4	8 FLM 6X12 F	133,41	1
F	RTS 60.150 F	60 2,4	152 6	8 FLM 6X12 F	167,80	1
F	RTS 60.200 F	60 2,4	202 8	10 FLM 6X12 F	210,00	1
F	RTS 60.300 F	60 2,4	302 11,9	12 FLM 6X12 F	322,62	1
F	RTS 60.400 F	60 2,4	402 15,8	12 FLM 6X12 F	420,00	1
F	RTS 60.500 F	60 2,4	502 19,8	12 FLM 6X12 F	550,30	1
F	RTS 60.600 F	60 2,4	602 23,7	12 FLM 6X12 F	697,50	1

Height 60 mm
Nominal 2 3/8 inches

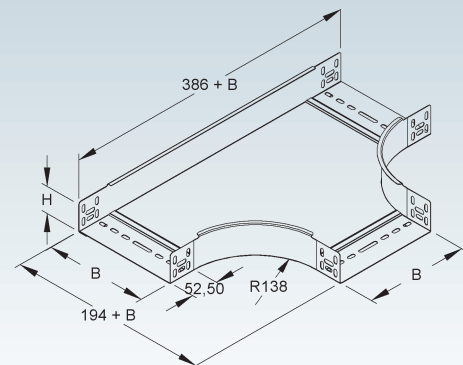

CABLE TRAY SYSTEM

Horizontal Cross

with integrated splice

	Model no.	Height H		Inside dimension B		Acc. incl.	Weight per 100 pcs kg	Pack/Box Qty
		mm	Inch	mm	Inch			
S	RKS 60.100	60	2,4	102	4	12 FLM 6X12	159,37	1
S	RKS 60.150	60	2,4	152	6	12 FLM 6X12	190,20	1
S	RKS 60.200	60	2,4	202	8	15 FLM 6X12	233,70	1
S	RKS 60.300	60	2,4	302	11,9	15 FLM 6X12	332,40	1
S	RKS 60.400	60	2,4	402	15,8	18 FLM 6X12	460,47	1
S	RKS 60.500	60	2,4	502	19,8	18 FLM 6X12	577,10	1
S	RKS 60.600	60	2,4	602	23,7	18 FLM 6X12	722,90	1
F	RKS 60.100 F	60	2,4	102	4	12 FLM 6X12 F	161,90	1
F	RKS 60.150 F	60	2,4	152	6	12 FLM 6X12 F	205,00	1
F	RKS 60.200 F	60	2,4	202	8	15 FLM 6X12 F	251,20	1
F	RKS 60.300 F	60	2,4	302	11,9	15 FLM 6X12 F	357,40	1
F	RKS 60.400 F	60	2,4	402	15,8	18 FLM 6X12 F	480,40	1
F	RKS 60.500 F	60	2,4	502	19,8	18 FLM 6X12 F	620,30	1
F	RKS 60.600 F	60	2,4	602	23,7	18 FLM 6X12 F	777,10	1

Height 60 mm
Nominal 2 3/8 inches

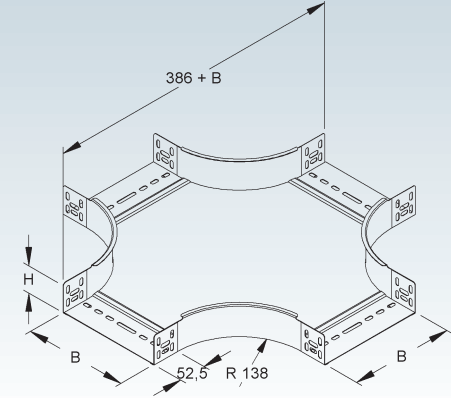

Reducer/Blind End

	Model no.	Height H		Width B		Width B1		Acc. incl.	Weight per 100 pcs kg	Pack/Box Qty
		mm	Inch	mm	Inch	mm	Inch			
S	RA 60.050	60	2,4	50	2	172	6,8	4 FLM 6X12	11,01	20
S	RA 60.150	60	2,4	150	5,9	272	10,7	4 FLM 6X12	16,94	20
S	RA 60.200	60	2,4	200	7,9	322	12,7	4 FLM 6X12	19,90	20
S	RA 60.400	60	2,4	400	15,7	522	20,6	4 FLM 6X12	31,77	20
S	RA 60.500	60	2,4	500	19,7	622	24,5	4 FLM 6X12	37,70	20
S	RA 60.600	60	2,4	600	23,6	722	28,4	4 FLM 6X12	43,63	20
F	RA 60.150 F	60	2,4	150	5,9	272	10,7	4 FLM 6X12 F	18,32	1
F	RA 60.200 F	60	2,4	200	7,9	322	12,7	4 FLM 6X12 F	21,58	1
F	RA 60.400 F	60	2,4	400	15,7	522	20,6	4 FLM 6X12 F	34,64	1
F	RA 60.500 F	60	2,4	500	19,7	622	24,5	4 FLM 6X12 F	41,16	1
F	RA 60.600 F	60	2,4	600	23,6	722	28,4	4 FLM 6X12 F	47,68	1
E3	RA 60.200 E3	60	2,4	200	7,9	322	12,7	4 FLM 6X12 E3	18,29	20
E3	RA 60.400 E3	60	2,4	400	15,7	522	20,6	4 FLM 6X12 E3	28,94	20
E3	RA 60.500 E3	60	2,4	500	19,7	622	24,5	4 FLM 6X12 E3	34,26	20
E3	RA 60.600 E3	60	2,4	600	23,6	722	28,4	4 FLM 6X12 E3	39,58	20

Height 60 mm
Nominal 2 3/8 inches

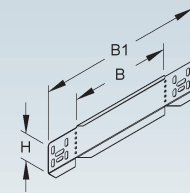

can be used as blind end or as reducer for cable trays

Adjustable Horizontal Splice/Reducer/Blind End

	Model no.	Height H		Width B		Width B1		Acc. incl.	Weight per 100 pcs kg	Pack/Box Qty
		mm	Inch	mm	Inch	mm	Inch			
S	RAW 60.100	60	2,4	100	3,9	222	8,7	4 FLM 6X12	13,71	20
S	RAW 60.300	60	2,4	300	11,8	422	16,6	4 FLM 6X12	25,58	20
F	RAW 60.100 F	60	2,4	100	3,9	222	8,7	4 FLM 6X12 F	14,77	1
F	RAW 60.300 F	60	2,4	300	11,8	422	16,6	4 FLM 6X12 F	27,83	1
E3	RAW 60.100 E3	60	2,4	100	3,9	222	8,7	4 FLM 6X12 E3	12,74	20
E3	RAW 60.300 E3	60	2,4	300	11,8	422	16,6	4 FLM 6X12 E3	23,38	20

Height 60 mm
Nominal 2 3/8 inches

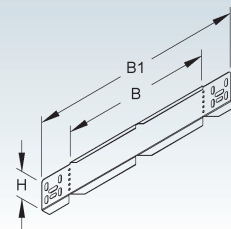

can be used as blind end or as reducer for cable trays

Adjustable Vertical Splice Plate

	Model no.	Height H		Acc. incl.	Weight per 100 pcs kg	Pack/Box Qty
		mm	Inch			
S	RGV 60	47	1,9	4 FLM 6X12	19,23	50
F	RGV 60 F	47	1,9	4 FLM 6X12 F	20,58	50
E3	RGV 60 E3	47	1,9	4 FLM 6X12 E3	14,38	20

Height 60 mm
Nominal 2 3/8 inches

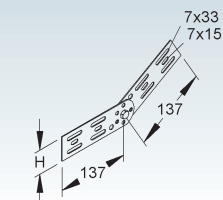

2 pieces required per joint



Splice/Link Kit

	Model no.	Height H		Width B		Acc. incl.	Weight per 100 pcs kg	Pack/Box Qty
		mm	Inch	mm	Inch			
S	RGE 60.100	60	2,4	100	3,9	2 SKM 8X16 V	52,51	1
S	RGE 60.150	60	2,4	150	5,9	2 SKM 8X16 V	57,65	1
S	RGE 60.200	60	2,4	200	7,9	2 SKM 8X16 V	62,79	1
S	RGE 60.300	60	2,4	300	11,8	2 SKM 8X16 V	73,07	1
S	RGE 60.400	60	2,4	400	15,7	2 SKM 8X16 V	83,35	1
S	RGE 60.500	60	2,4	500	19,7	2 SKM 8X16 V	93,63	1
S	RGE 60.600	60	2,4	600	23,6	2 SKM 8X16 V	103,91	1
F	RGE 60.100 F	60	2,4	100	3,9	2 SKM 8X16 F	57,42	1
F	RGE 60.150 F	60	2,4	150	5,9	2 SKM 8X16 F	63,07	1
F	RGE 60.200 F	60	2,4	200	7,9	2 SKM 8X16 F	68,73	1
F	RGE 60.300 F	60	2,4	300	11,8	2 SKM 8X16 F	80,03	1
F	RGE 60.400 F	60	2,4	400	15,7	2 SKM 8X16 F	91,34	1
F	RGE 60.500 F	60	2,4	500	19,7	2 SKM 8X16 F	102,65	1
F	RGE 60.600 F	60	2,4	600	23,6	2 SKM 8X16 F	113,96	1

Height 60 mm
Nominal 2 3/8 inches

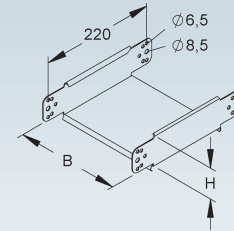

for linking sections of tray with a vertical displacement
With rounded edges to protect cables.

Vertical Inside Elbow 90°

with integrated splice

	Model no.	Height H		Inside dimension B		Acc. incl.	Weight per 100 pcs kg	Pack/Box Qty
		mm	Inch	mm	Inch			
S	RSD 60.100	60	2,4	102	4	4 FLM 6X12	78,00	1
S	RSD 60.150	60	2,4	152	6	4 FLM 6X12	95,19	1
S	RSD 60.200	60	2,4	202	8	5 FLM 6X12	113,30	1
S	RSD 60.300	60	2,4	302	11,9	5 FLM 6X12	147,68	1
S	RSD 60.400	60	2,4	402	15,8	6 FLM 6X12	182,98	1
S	RSD 60.500	60	2,4	502	19,8	6 FLM 6X12	217,36	1
S	RSD 60.600	60	2,4	602	23,7	6 FLM 6X12	251,74	1
F	RSD 60.100 F	60	2,4	102	4	4 FLM 6X12 F	85,98	1
F	RSD 60.200 F	60	2,4	202	8	5 FLM 6X12 F	124,86	1
F	RSD 60.300 F	60	2,4	302	11,9	5 FLM 6X12 F	162,68	1
F	RSD 60.400 F	60	2,4	402	15,8	6 FLM 6X12 F	201,55	1
F	RSD 60.500 F	60	2,4	502	19,8	6 FLM 6X12 F	239,37	1
F	RSD 60.600 F	60	2,4	602	23,7	6 FLM 6X12 F	277,19	1

Height 60 mm
Nominal 2 3/8 inches

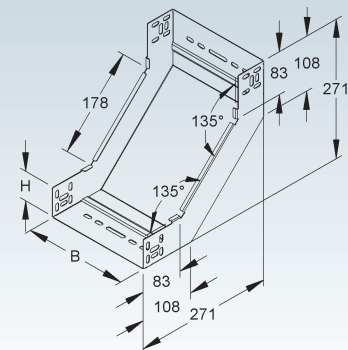

Vertical Outside Elbow 90°

with integrated splice

	Model no.	Height H		Inside dimension B		Acc. incl.	Weight per 100 pcs kg	Pack/Box Qty
		mm	Inch	mm	Inch			
S	RFD 60.100	60	2,4	102	4	4 FLM 6X12	71,70	1
S	RFD 60.150	60	2,4	152	6	4 FLM 6X12	85,48	1
S	RFD 60.200	60	2,4	202	8	5 FLM 6X12	99,22	1
S	RFD 60.300	60	2,4	302	11,9	5 FLM 6X12	125,95	1
S	RFD 60.400	60	2,4	402	15,8	6 FLM 6X12	153,47	1
S	RFD 60.500	60	2,4	502	19,8	6 FLM 6X12	180,19	1
S	RFD 60.600	60	2,4	602	23,7	6 FLM 6X12	206,91	1
F	RFD 60.100 F	60	2,4	102	4	4 FLM 6X12 F	78,95	1
F	RFD 60.200 F	60	2,4	202	8	5 FLM 6X12 F	109,24	1
F	RFD 60.300 F	60	2,4	302	11,9	5 FLM 6X12 F	138,65	1
F	RFD 60.400 F	60	2,4	402	15,8	6 FLM 6X12 F	168,94	1
F	RFD 60.500 F	60	2,4	502	19,8	6 FLM 6X12 F	198,33	1
F	RFD 60.600 F	60	2,4	602	23,7	6 FLM 6X12 F	227,72	1

Height 60 mm
Nominal 2 3/8 inches

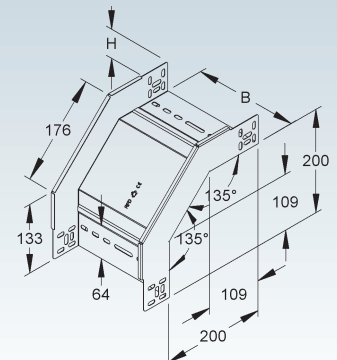

CABLE TRAY SYSTEM

Vertical Tee Down, lengthwise

with integrated splice

	Model no.	Height H		Inside dimension B		Length A		Height H1	Acc. incl.	Weight per 100 pcs kg	Pack/Box Qty
		mm	Inch	mm	Inch	mm	Inch				
S	RTL 60.100	60	2,4	102	4	360	14,2	131	16 FLM 6X12	152,49	1
S	RTL 60.150	60	2,4	152	6	410	16,1	131	16 FLM 6X12	186,97	1
S	RTL 60.200	60	2,4	202	8	500	19,7	153	19 FLM 6X12	263,28	1
S	RTL 60.300	60	2,4	302	11,9	780	30,7	244	21 FLM 6X12	519,06	1
S	RTL 60.400	60	2,4	402	15,8	880	34,6	243	24 FLM 6X12	664,44	1
S	RTL 60.500	60	2,4	502	19,8	980	38,6	243	24 FLM 6X12	818,83	1
S	RTL 60.600	60	2,4	602	23,7	1080	42,5	243	24 FLM 6X12	988,21	1

Size of run and tap tray is identical.

Delivered as a kit (not assembled).

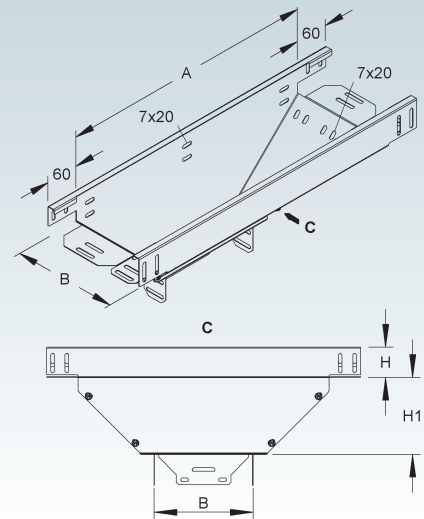
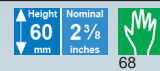

Vertical Tee Down, crosswise

with integrated splice

	Model no.	Height H		Inside dimension B		Length A		Acc. incl.	Weight per 100 pcs kg	Pack/Box Qty
		mm	Inch	mm	Inch	mm	Inch			
S	RTQ 60.100	60	2,4	102	4	311	12,2	8 FLM 6X12	100,75	1
S	RTQ 60.150	60	2,4	152	6	311	12,2	8 FLM 6X12	118,03	1
S	RTQ 60.200	60	2,4	202	8	311	12,2	10 FLM 6X12	136,91	1
S	RTQ 60.300	60	2,4	302	11,9	311	12,2	12 FLM 6X12	173,07	1
S	RTQ 60.400	60	2,4	402	15,8	311	12,2	12 FLM 6X12	207,63	1
S	RTQ 60.500	60	2,4	502	19,8	311	12,2	12 FLM 6X12	242,19	1
S	RTQ 60.600	60	2,4	602	23,7	311	12,2	12 FLM 6X12	276,75	1

Size of run and tap tray is identical.

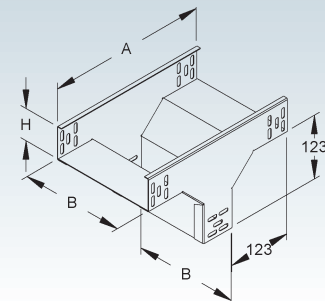

Edge Protection Plate

	Model no.	Width B		Acc. incl.	Weight per 100 pcs kg	Pack/Box Qty
		mm	Inch			
S	RKB 100	92	3,6	1 FLM 6X12	4,40	10
S	RKB 150	142	5,6	2 FLM 6X12	7,15	10
S	RKB 200	192	7,6	2 FLM 6X12	9,13	10
S	RKB 300	292	11,5	2 FLM 6X12	13,27	10
S	RKB 400	392	15,4	2 FLM 6X12	17,40	10
S	RKB 500	492	19,4	2 FLM 6X12	21,53	10
S	RKB 600	592	23,3	2 FLM 6X12	25,67	10
F	RKB 100 F	92	3,6	1 FLM 6X12 F	4,89	50
F	RKB 150 F	142	5,6	2 FLM 6X12 F	7,96	50
F	RKB 200 F	192	7,6	2 FLM 6X12 F	10,13	50
F	RKB 300 F	292	11,5	2 FLM 6X12 F	14,69	50
F	RKB 400 F	392	15,4	2 FLM 6X12 F	19,23	50
F	RKB 500 F	492	19,4	2 FLM 6X12 F	23,77	50
F	RKB 600 F	592	23,3	2 FLM 6X12 F	28,33	50

with rounded edges to protect cables at the joint and to reinforce the bottom of cable trays

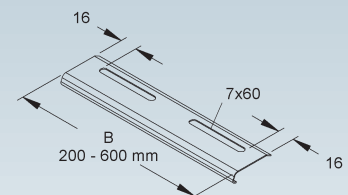

NOTES

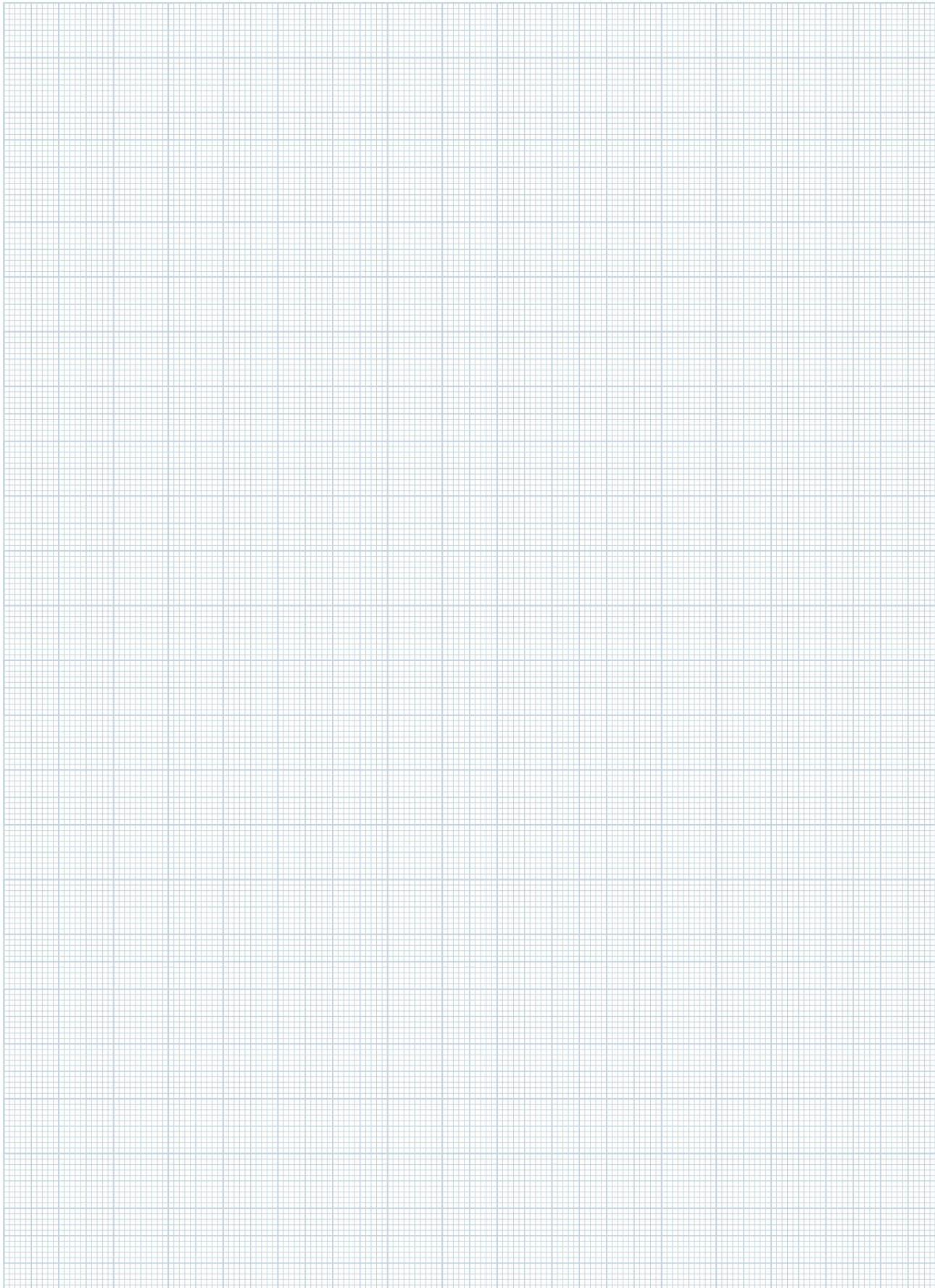

CABLE TRAY SYSTEM

Available Side Rail Heights

SYSTEM	Distribution Cable Tray	RLCPV...	Page 207
	Heavy Duty Cable Tray	RS...	Page 208
	Heavy Duty Cable Tray	RSU...	Page 209
ACCESSORIES	Boltless Splice Plate	RVC 85	Page 207
	Bottom Connection Plate	RSLC 400	Page 208
	Edge Protection Ring	KSR 40 A	Page 208
	Universal Splice Plate	RSUV 85-1.5/200 S	Page 209
	U-shaped Splice Plate	RV...	Page 209
	Divider	RW 85...	Page 209
	Splice Plate for Divider	RTV 85 E2	Page 210
	Mounting Plate for Divider	RTPH 50	Page 210
	Mounting Plate for Divider with M6 Stud	RTPH 50 M6	Page 210
	Extension Horizontal Tee	RTA...	Page 211
	Horizontal Elbow Building Block	REK...	Page 211
	Flexible Horizontal Elbow 0-90°	RBAV...	Page 211
	Horizontal Elbow 45°	RBA...	Page 211
	Horizontal Elbow 90°	RES...	Page 212
	Horizontal Tee	RTS...	Page 212
	Horizontal Cross	RKS...	Page 212
	Reducer/Blind End	RA...	Page 213
	Adjustable Horizontal Splice/Reducer/Blind End	RAW...	Page 213
	Adjustable Vertical Splice Plate	RGV...	Page 213
	Splice/Link Kit	RGE...	Page 213
	Vertical Inside Elbow 45°	RSB...	Page 214
	Vertical Inside Elbow 90°	RSD...	Page 214
	Vertical Outside Elbow 45°	RFB...	Page 214
	Vertical Outside Elbow 90°	RFD...	Page 214
	Vertical Tee Down, lengthwise	RTL...	Page 215
	Vertical Tee Down, crosswise	RTQ...	Page 215
	Edge Protection Plate	RKB...	Page 215

See covers for cable trays and fittings on page 229 and following.



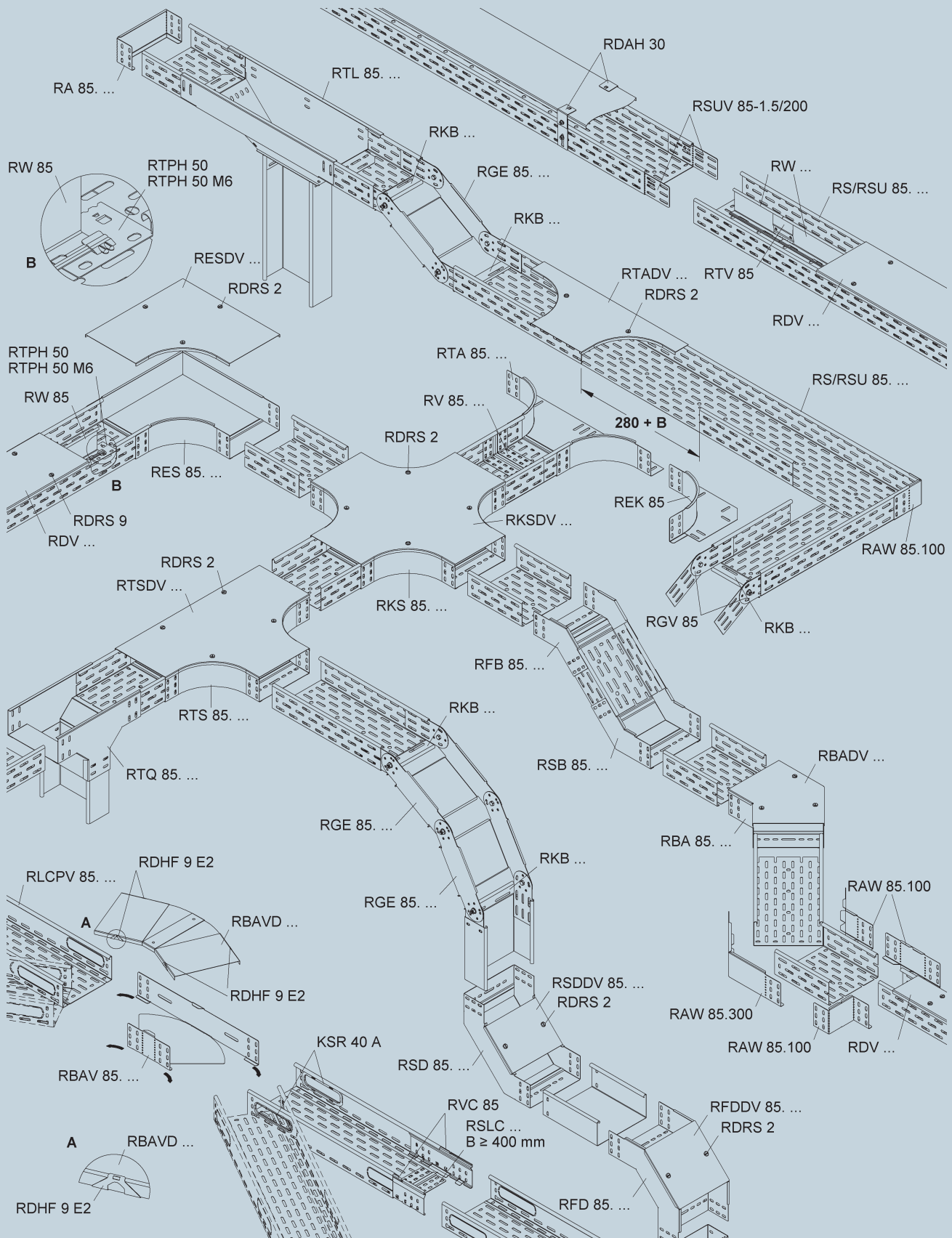

CABLE TRAY SYSTEM

Load/Span Class Designation in accordance with NEMA VE 1 and CSA C22.2 No. 126.1

Niedax Series	Minimum Area		Load class in accordance to NEMA VE 1		
	(calculational) mm ² / in. ²	in accordance to NEMA VE 2 mm ² / in. ²	Rated Load Kg/m / lb./ft.	Support spacing m / ft.	Load/Span Class
RLCPVX 85.100 OV	186.0 / 0.29	129 / 0.2	116 / 78.4	2.4 / 8	8B, C
RLCPVX 85.200 OV	272.0 / 0.42	258 / 0.4	116 / 78.4	2.4 / 8	8B, C
RLCPVX 85.300 OV	358.0 / 0.55	258 / 0.4	116 / 78.4	2.4 / 8	8B, C
RLCPVX 85.400 OV	444.0 / 0.69	258 / 0.4	116 / 78.4	2.4 / 8	8B, C
RSX 85.100, ... F	331.5 / 0.51	258 / 0.4	266.5 / 179	2 / 6.6	5A, A
RSX 85.200, ... F	439.5 / 0.68	258 / 0.4	266.5 / 179	2 / 6.6	5A, A
RSX 85.300, ... F	547.5 / 0.85	452 / 0.7	266.5 / 179	2 / 6.6	5A, A
RSX 85.400, ... F	655.5 / 1.02	645 / 1.0	266.5 / 179	2 / 6.6	5A, A
RSX 85.500, ... F	763.5 / 1.18	645 / 1.0	266.5 / 179	2 / 6.6	5A, A
RSX 85.600, ... F	871.5 / 1.35	645 / 1.0	266.5 / 179	2 / 6.6	5A, A
RSUX 85.100, ... F	436.5 / 0.68	258 / 0.4	266.5 / 179	2 / 6.6	5A, A
RSUX 85.200, ... F	586.5 / 0.91	452 / 0.7	266.5 / 179	2 / 6.6	5A, A
RSUX 85.300, ... F	736.5 / 1.14	645 / 1.0	266.5 / 179	2 / 6.6	5A, A
RSUX 85.400, ... F	886.5 / 1.37	645 / 1.0	266.5 / 179	2 / 6.6	5A, A
RSUX 85.500, ... F	1036.5 / 1.61	968 / 1.5	266.5 / 179	2 / 6.6	5A, A
RSUX 85.600, ... F	1186.5 / 1.84	968 / 1.5	266.5 / 179	2 / 6.6	5A, A



Distribution Cable Tray

ventilated

	Model no.	Height H		Width B		Thick-ness t mm	Weight per 100 m kg	Pack/Box Qty
		mm	Inch	mm	Inch			
S	RLCPV 85.100 OV	85	3,3	100	3,9	1	210,61	2 x 3 m
S	RLCPV 85.200 OV	85	3,3	200	7,9	1	276,10	2 x 3 m
S	RLCPV 85.300 OV	85	3,3	300	11,8	1	341,60	2 x 3 m
S	RLCPV 85.400 OV	85	3,3	400	15,7	1	407,09	2 x 3 m

With pre-cut cable drop outs, size 40 mm x 150 mm.

Please order two RVC 85 splice plates for every piece of tray.

Load Chart: q = uniformly distributed load (tested according to DIN EN IEC 61537 standard)

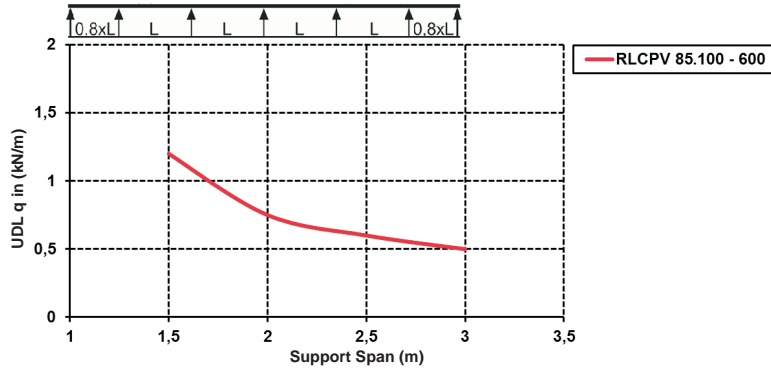

Height 85 mm
Nominal 3 3/8 inches
Eye icon
52

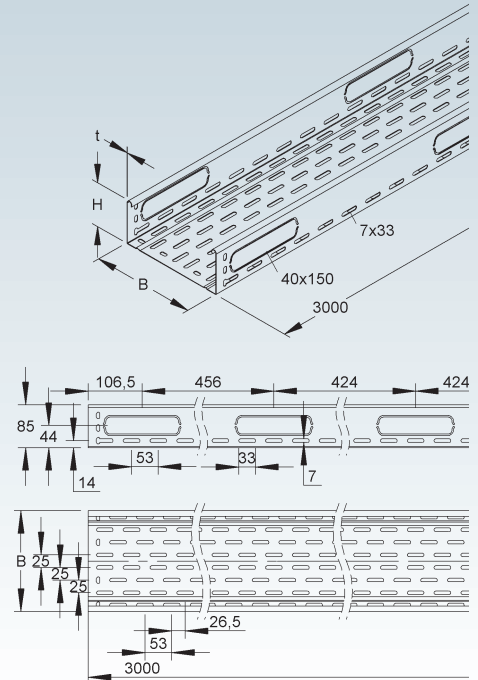

Boltless Splice Plate

	Model no.	Height H		Weight per 100 pcs kg	Pack/Box Qty
		mm	Inch		
S	RVC 85	85	3,3	23,54	50

2 pieces required per joint

Suitable for: cable tray RLCPV 85...

Height 85 mm
Nominal 3 3/8 inches
Clock icon

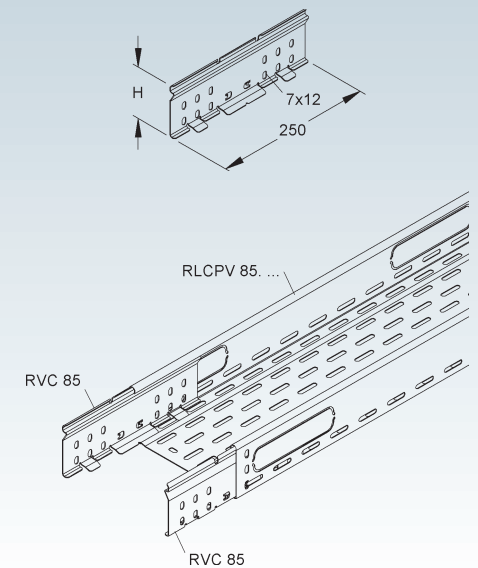

CABLE TRAY SYSTEM

Bottom Connection Plate

Model no.	Width B mm Inch	Acc. incl.	Weight per 100 pcs kg	Pack/Box Qty
S RSLC 400	339 13,3	4 FLM 6X12	26,55	10

for stabilizing the bottom plate of cable trays

Suitable for: cable trays RLCI 60... und RLCPV 85...

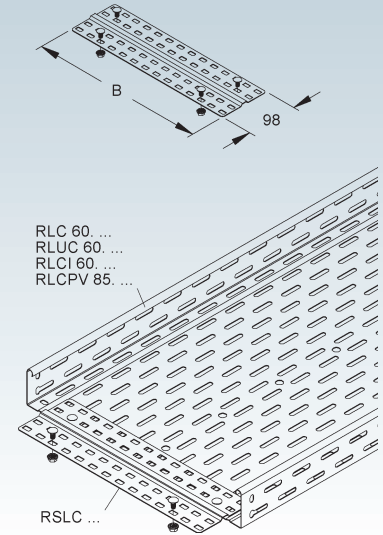

Edge Protection Ring

UV resistant

Model no.	Color	Inside height H mm Inch	Inside dimension B mm Inch	Weight per 100 pcs kg	Pack/Box Qty
K04 KSR 40 A	black	34,5 1,4	144,5 5,7	0,97	20

to protect cables at the knockouts

Suitable for: distribution cable trays RLCPV 85... and RSV 110...

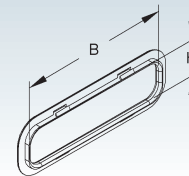

Heavy Duty Cable Tray

ventilated

Model no.	Height H mm Inch	Width B mm Inch	Thickness t mm	Acc. incl.	Weight per 100 m kg	Pack/Box Qty
S RS 85.100	85 3,3	100 3,9	1,5	8 FLM 6X12	298,00	2 x 3 m
S RS 85.200	85 3,3	200 7,9	1,5	10 FLM 6X12	397,73	2 x 3 m
S RS 85.300	85 3,3	300 11,8	1,5	10 FLM 6X12	496,94	2 x 3 m
S RS 85.400	85 3,3	400 15,7	1,5	12 FLM 6X12	596,67	2 x 3 m
S RS 85.500	85 3,3	500 19,7	1,5	12 FLM 6X12	695,88	2 x 3 m
S RS 85.600	85 3,3	600 23,6	1,5	12 FLM 6X12	795,09	2 x 3 m
F RS 85.100 F	85 3,3	100 3,9	1,5	8 FLM 6X12 F	327,58	2 x 3 m
F RS 85.200 F	85 3,3	200 7,9	1,5	10 FLM 6X12 F	437,24	2 x 3 m
F RS 85.300 F	85 3,3	300 11,8	1,5	10 FLM 6X12 F	546,37	2 x 3 m
F RS 85.400 F	85 3,3	400 15,7	1,5	12 FLM 6X12 F	656,02	2 x 3 m
F RS 85.500 F	85 3,3	500 19,7	1,5	12 FLM 6X12 F	765,15	2 x 3 m
F RS 85.600 F	85 3,3	600 23,6	1,5	12 FLM 6X12 F	874,28	2 x 3 m

Centered punchholes allow hanging with M10 (3/8") threaded rod.

Bottom plate and side rail perforated with staggered punch holes.

One RV... splice plate included with every piece of cable tray.

Load Chart: q = uniformly distributed load (tested according to DIN EN IEC 61537 standard)

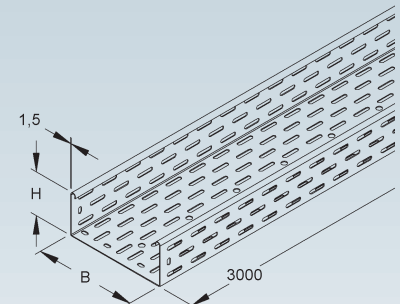
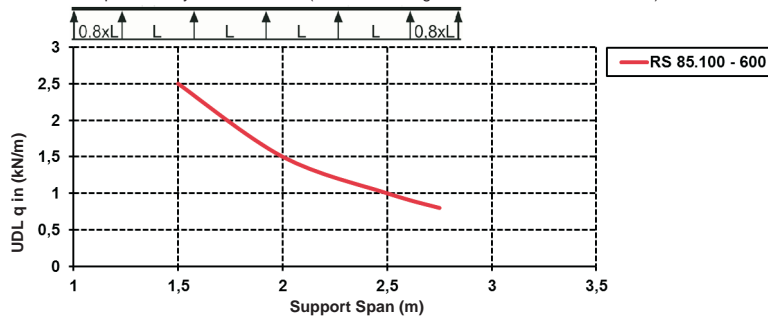

Heavy Duty Cable Tray

solid, but with splice plate perforation

	Model no.	Height H		Width B		Thick-ness t	Acc. incl.	Weight per 100 m kg	Pack/Box Qty
		mm	Inch	mm	Inch				
S	RSU 85.100	85	3,3	100	3,9	1,5	8 FLM 6X12	349,72	2 x 3 m
S	RSU 85.200	85	3,3	200	7,9	1,5	10 FLM 6X12	470,04	2 x 3 m
S	RSU 85.300	85	3,3	300	11,8	1,5	10 FLM 6X12	589,77	2 x 3 m
S	RSU 85.400	85	3,3	400	15,7	1,5	12 FLM 6X12	710,03	2 x 3 m
S	RSU 85.500	85	3,3	500	19,7	1,5	12 FLM 6X12	829,83	2 x 3 m
S	RSU 85.600	85	3,3	600	23,6	1,5	12 FLM 6X12	949,62	2 x 3 m
F	RSU 85.100 F	85	3,3	100	3,9	1,5	8 FLM 6X12 F	384,44	2 x 3 m
F	RSU 85.200 F	85	3,3	200	7,9	1,5	10 FLM 6X12 F	516,74	2 x 3 m
F	RSU 85.300 F	85	3,3	300	11,8	1,5	10 FLM 6X12 F	648,45	2 x 3 m
F	RSU 85.400 F	85	3,3	400	15,7	1,5	12 FLM 6X12 F	780,68	2 x 3 m
F	RSU 85.500 F	85	3,3	500	19,7	1,5	12 FLM 6X12 F	912,45	2 x 3 m
F	RSU 85.600 F	85	3,3	600	23,6	1,5	12 FLM 6X12 F	1.044,23	2 x 3 m

One RV... splice plate included with every piece of cable tray.

Height 85 mm
Nominal 3 3/8 inches

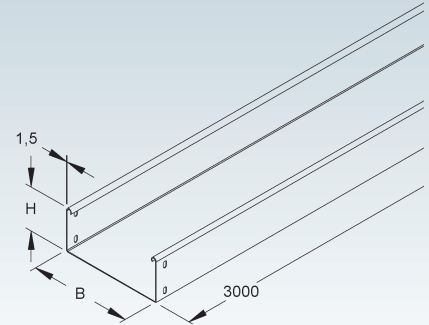

Universal Splice Plate

	Model no.	Height H		Width B		Thick-ness t	Acc. incl.	Weight per 100 pcs kg	Pack/Box Qty
		mm	Inch	mm	Inch				
S	RSUV 85-1.5/200 S	73	2,9	200	7,9	1,5	4 FLM 6X12	17,01	50

for straight and angled joints

2 pieces required per joint

Height 85 mm
Nominal 3 3/8 inches

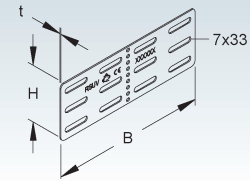

U-Shaped Splice Plate

	Model no.	Height H		Width B		Acc. incl.	Weight per 100 pcs kg	Pack/Box Qty
		mm	Inch	mm	Inch			
S	RV 85.100	73	2,9	97	3,8	8 FLM 6X12	20,70	1
S	RV 85.200	73	2,9	197	7,8	10 FLM 6X12	28,41	1
S	RV 85.300	73	2,9	297	11,7	10 FLM 6X12	34,55	1
S	RV 85.400	73	2,9	397	15,6	12 FLM 6X12	42,27	1
S	RV 85.500	73	2,9	497	19,6	12 FLM 6X12	48,40	1
S	RV 85.600	73	2,9	597	23,5	12 FLM 6X12	54,54	1
F	RV 85.100 F	73	2,9	97	3,8	8 FLM 6X12 F	22,14	1
F	RV 85.200 F	73	2,9	197	7,8	10 FLM 6X12 F	30,46	1
F	RV 85.300 F	73	2,9	297	11,7	10 FLM 6X12 F	37,21	1
F	RV 85.400 F	73	2,9	397	15,6	12 FLM 6X12 F	45,55	1
F	RV 85.500 F	73	2,9	497	19,6	12 FLM 6X12 F	52,29	1
F	RV 85.600 F	73	2,9	597	23,5	12 FLM 6X12 F	59,05	1

Suitable for: cable trays RL..., RLU..., RS... and RSU...

Height 85 mm
Nominal 3 3/8 inches

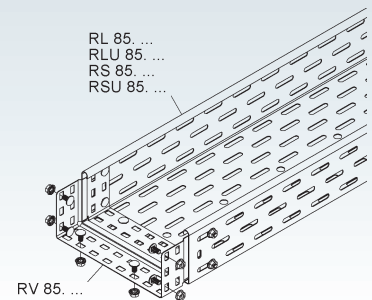
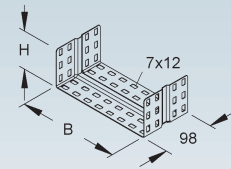

Divider

	Model no.	Height H		Thick-ness t	Acc. incl.	Weight per 100 m kg	Pack/Box Qty
		mm	Inch				
S	RW 85	80	3,1	0,9	4 FLM 6X12	77,65	10 x 3 m
F	RW 85 F	80	3,1	0,9	4 FLM 6X12 F	85,30	10 x 3 m

to separate wires and cables of different voltage levels or with different functions

Height 85 mm
Nominal 3 3/8 inches

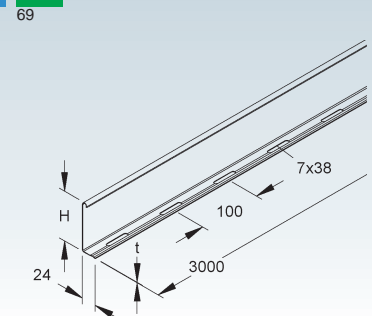

CABLE TRAY SYSTEM

Splice Plate for Divider

Model no.	Height H	Length L	Weight per 100 pcs kg	Pack/ Box Qty
	mm Inch	mm Inch		
E2 RTV 85 E2	79,5 3,1	80 3,1	2,03	20

for positive locking connections and proper bonding of dividers

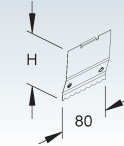
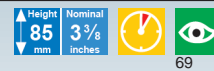

Mounting Plate for Divider

Model no.	Length L	Width B	Thick- ness t	Weight per 100 pcs kg	Pack/ Box Qty
	mm Inch	mm Inch	mm		
S RTPH 50	83 3,3	59 2,3	0,9	3,36	20

Mounting plate with locking mechanism for fast installation of dividers in ventilated cable tray series RL.../RS... series (min. width 100 mm) and ventilated cable trays series RLCI 60... / RLCPV 85... (min. width 200 mm).

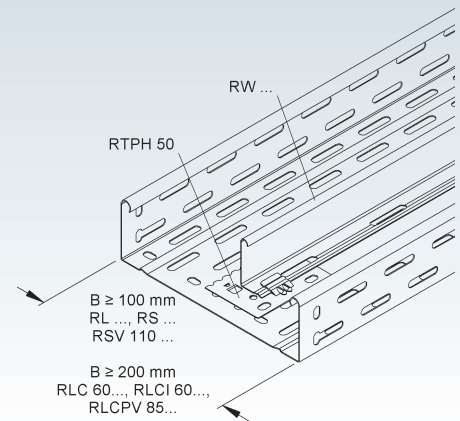
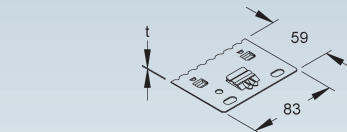

Mounting Plate for Divider with M6 Stud

Model no.	Length L	Width B	Thick- ness t	Acc. incl.	Weight per 100 pcs kg	Pack/ Box Qty
	mm Inch	mm Inch	mm			
S RTPH 50 M6	83 3,3	59 2,3	0,9	1 SMF6	3,98	50

Mounting plate with locking mechanism for fast installation of dividers in ventilated cable tray series RL.../RS... series (min. width 100 mm) and ventilated cable trays series RLCI 60... / RLCPV 85... (min. width 200 mm). With M6 locking stud.

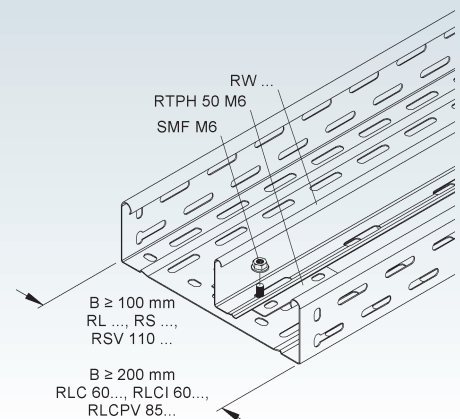
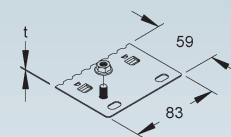

Extension Horizontal Tee

with integrated splice

	Model no.	Height H		Inside dimension B		Acc. incl.	Weight per 100 pcs kg	Pack/Box Qty
		mm	Inch	mm	Inch			
S	RTA 85.100	85	3,3	102	4	10 FLM 6X12	94,6	1
S	RTA 85.200	85	3,3	202	8	10 FLM 6X12	111,5	1
S	RTA 85.300	85	3,3	302	11,9	10 FLM 6X12	128,4	1
S	RTA 85.400	85	3,3	402	15,8	10 FLM 6X12	145,6	1
S	RTA 85.500	85	3,3	502	19,8	10 FLM 6X12	162,1	1
S	RTA 85.600	85	3,3	602	23,7	10 FLM 6X12	179,0	1
F	RTA 85.100 F	85	3,3	102	4	10 FLM 6X12 F	103,3	1
F	RTA 85.200 F	85	3,3	202	8	10 FLM 6X12 F	121,9	1
F	RTA 85.300 F	85	3,3	302	11,9	10 FLM 6X12 F	140,4	1
F	RTA 85.400 F	85	3,3	402	15,8	10 FLM 6X12 F	159,4	1
F	RTA 85.500 F	85	3,3	502	19,8	10 FLM 6X12 F	177,5	1
F	RTA 85.600 F	85	3,3	602	23,7	10 FLM 6X12 F	196,1	1

Height 85 mm Nominal 3 3/8 inches
64 65

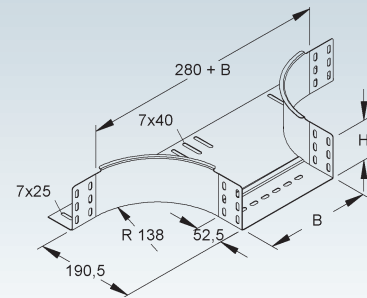

Horizontal Elbow Building Block

with integrated splice

	Model no.	Height H		Acc. incl.	Weight per 100 pcs kg	Pack/Box Qty
		mm	Inch			
S	REK 85	85	3,3	6 FLM 6X12	46,07	1
F	REK 85 F	85	3,3	6 FLM 6X12 F	44,10	1

for building customized horizontal cable tray fittings

Height 85 mm Nominal 3 3/8 inches
66 67

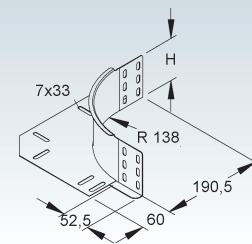

Flexible Horizontal Elbow 0-90°

with integrated splice

	Model no.	Height H		Inside dimension B		Acc. incl.	Weight per 100 pcs kg	Pack/Box Qty
		mm	Inch	mm	Inch			
S	RBAV 85.100	85	3,3	100	3,9	10 FLM 6X12	54,48	1
S	RBAV 85.200	85	3,3	200	7,9	10 FLM 6X12	86,81	1
S	RBAV 85.300	85	3,3	300	11,8	10 FLM 6X12	131,92	1
S	RBAV 85.400	85	3,3	400	15,7	10 FLM 6X12	186,69	1
S	RBAV 85.500	85	3,3	500	19,7	14 FLM 6X12	260,28	1
S	RBAV 85.600	85	3,3	600	23,6	14 FLM 6X12	341,84	1

Height 85 mm Nominal 3 3/8 inches

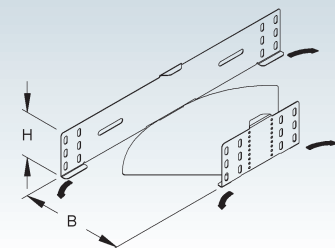

Horizontal Elbow 45°

with integrated splice

	Model no.	Height H		Inside dimension B		Acc. incl.	Weight per 100 pcs kg	Pack/Box Qty
		mm	Inch	mm	Inch			
S	RBA 85.100	85	3,3	102	4	4 FLM 6X12	54,70	1
S	RBA 85.200	85	3,3	202	8	5 FLM 6X12	86,70	1
S	RBA 85.300	85	3,3	302	11,9	5 FLM 6X12	125,20	1
S	RBA 85.400	85	3,3	402	15,8	6 FLM 6X12	170,40	1
S	RBA 85.500	85	3,3	502	19,8	6 FLM 6X12	221,80	1
S	RBA 85.600	85	3,3	602	23,7	6 FLM 6X12	280,00	1
F	RBA 85.100 F	85	3,3	102	4	4 FLM 6X12 F	58,80	1
F	RBA 85.200 F	85	3,3	202	8	5 FLM 6X12 F	93,20	1
F	RBA 85.300 F	85	3,3	302	11,9	5 FLM 6X12 F	134,60	1
F	RBA 85.400 F	85	3,3	402	15,8	6 FLM 6X12 F	191,75	1
F	RBA 85.500 F	85	3,3	502	19,8	6 FLM 6X12 F	238,50	1
F	RBA 85.600 F	85	3,3	602	23,7	6 FLM 6X12 F	301,00	1

Height 85 mm Nominal 3 3/8 inches

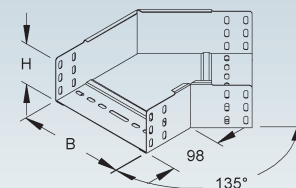

CABLE TRAY SYSTEM

Horizontal Elbow 90°

with integrated splice

Model no.		Height H		Inside dimension B		Acc. incl.	Weight per 100 pcs kg	Pack/Box Qty
		mm	Inch	mm	Inch			
S	RES 85.100	85	3,3	102	4	4 FLM 6X12	110,50	1
S	RES 85.200	85	3,3	202	8	5 FLM 6X12	185,00	1
S	RES 85.300	85	3,3	302	11,9	5 FLM 6X12	271,10	1
S	RES 85.400	85	3,3	402	15,8	6 FLM 6X12	372,40	1
S	RES 85.500	85	3,3	502	19,8	6 FLM 6X12	489,90	1
S	RES 85.600	85	3,3	602	23,7	6 FLM 6X12	623,10	1
F	RES 85.100 F	85	3,3	102	4	4 FLM 6X12 F	125,16	1
F	RES 85.200 F	85	3,3	202	8	5 FLM 6X12 F	198,90	1
F	RES 85.300 F	85	3,3	302	11,9	5 FLM 6X12 F	291,40	1
F	RES 85.400 F	85	3,3	402	15,8	6 FLM 6X12 F	400,40	1
F	RES 85.500 F	85	3,3	502	19,8	6 FLM 6X12 F	526,60	1
F	RES 85.600 F	85	3,3	602	23,7	6 FLM 6X12 F	669,80	1

▲ Height 85 mm
▼ Nominal 3 3/8 inches

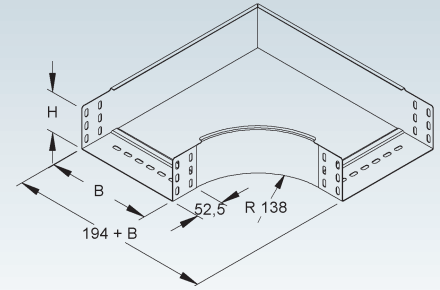

Horizontal Tee

with integrated splice

Model no.		Height H		Inside dimension B		Acc. incl.	Weight per 100 pcs kg	Pack/Box Qty
		mm	Inch	mm	Inch			
S	RTS 85.100	85	3,3	102	4	8 FLM 6X12	143,90	1
S	RTS 85.200	85	3,3	202	8	10 FLM 6X12	226,50	1
S	RTS 85.300	85	3,3	302	11,9	10 FLM 6X12	318,90	1
S	RTS 85.400	85	3,3	402	15,8	12 FLM 6X12	427,00	1
S	RTS 85.500	85	3,3	502	19,8	12 FLM 6X12	550,80	1
S	RTS 85.600	85	3,3	602	23,7	12 FLM 6X12	690,30	1
F	RTS 85.100 F	85	3,3	102	4	8 FLM 6X12 F	166,69	1
F	RTS 85.200 F	85	3,3	202	8	10 FLM 6X12 F	243,40	1
F	RTS 85.300 F	85	3,3	302	11,9	10 FLM 6X12 F	342,80	1
F	RTS 85.400 F	85	3,3	402	15,8	12 FLM 6X12 F	459,00	1
F	RTS 85.500 F	85	3,3	502	19,8	12 FLM 6X12 F	592,10	1
F	RTS 85.600 F	85	3,3	602	23,7	12 FLM 6X12 F	742,10	1

▲ Height 85 mm
▼ Nominal 3 3/8 inches

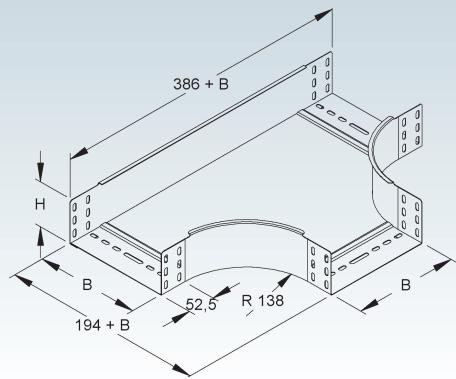

Horizontal Cross

with integrated splice

Model no.		Height H		Inside dimension B		Acc. incl.	Weight per 100 pcs kg	Pack/Box Qty
		mm	Inch	mm	Inch			
S	RKS 85.100	85	3,3	102	4	12 FLM 6X12	182,9	1
S	RKS 85.200	85	3,3	202	8	15 FLM 6X12	266,0	1
S	RKS 85.300	85	3,3	302	11,9	15 FLM 6X12	364,8	1
S	RKS 85.400	85	3,3	402	15,8	18 FLM 6X12	479,2	1
S	RKS 85.500	85	3,3	502	19,8	18 FLM 6X12	609,4	1
S	RKS 85.600	85	3,3	602	23,7	18 FLM 6X12	755,3	1
F	RKS 85.100 F	85	3,3	102	4	12 FLM 6X12 F	196,6	1
F	RKS 85.200 F	85	3,3	202	8	15 FLM 6X12 F	285,9	1
F	RKS 85.300 F	85	3,3	302	11,9	15 FLM 6X12 F	392,1	1
F	RKS 85.400 F	85	3,3	402	15,8	18 FLM 6X12 F	515,2	1
F	RKS 85.500 F	85	3,3	502	19,8	18 FLM 6X12 F	655,1	1
F	RKS 85.600 F	85	3,3	602	23,7	18 FLM 6X12 F	811,9	1

▲ Height 85 mm
▼ Nominal 3 3/8 inches

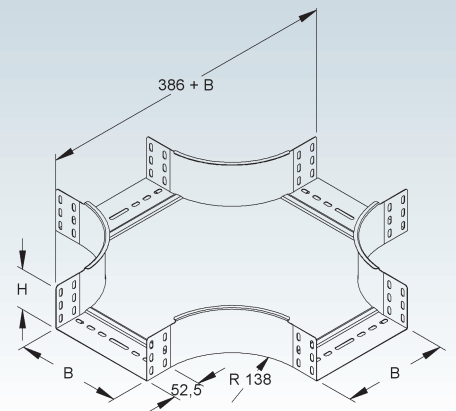

Reducer/Blind End

	Model no.	Height H	Width B	Width B1	Acc. incl.	Weight per 100 pcs kg	Pack/Box Qty
		mm Inch	mm Inch	mm Inch			
S	RA 85.200	85 3,3	200 7,9	322 12,7	4 FLM 6X12	28,17	20
S	RA 85.400	85 3,3	400 15,7	522 20,6	4 FLM 6X12	45,24	20
S	RA 85.500	85 3,3	500 19,7	622 24,5	4 FLM 6X12	54,17	20
S	RA 85.600	85 3,3	600 23,6	722 28,4	4 FLM 6X12	62,30	20
F	RA 85.200 F	85 3,3	200 7,9	322 12,7	4 FLM 6X12 F	31,17	1
F	RA 85.400 F	85 3,3	400 15,7	522 20,6	4 FLM 6X12 F	50,38	1
F	RA 85.500 F	85 3,3	500 19,7	622 24,5	4 FLM 6X12 F	59,33	1
F	RA 85.600 F	85 3,3	600 23,6	722 28,4	4 FLM 6X12 F	68,71	1

can be used as blind end or as reducer for cable tray

Height 85 mm
Nominal 3 3/8 inches

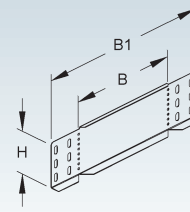

Adjustable Horizontal Splice/Reducer/Blind End

	Model no.	Height H	Width B	Width B1	Acc. incl.	Weight per 100 pcs kg	Pack/Box Qty
		mm Inch	mm Inch	mm Inch			
S	RAW 85.100	85 3,3	100 3,9	222 8,7	4 FLM 6X12	27,97	20
S	RAW 85.300	85 3,3	300 11,8	422 16,6	4 FLM 6X12	36,21	20
F	RAW 85.100 F	85 3,3	100 3,9	222 8,7	4 FLM 6X12 F	30,95	1
F	RAW 85.300 F	85 3,3	300 11,8	422 16,6	4 FLM 6X12 F	40,01	1

can be used as blind end or as reducer for cable tray

Height 85 mm
Nominal 3 3/8 inches

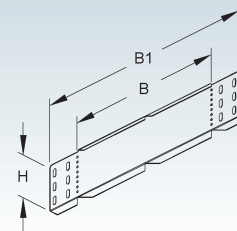

Adjustable Vertical Splice Plate

	Model no.	Height H	Acc. incl.	Weight per 100 pcs kg	Pack/Box Qty
		mm Inch			
S	RGV 85	73 2,9	4 FLM 6X12	29,63	25
F	RGV 85 F	73 2,9	4 FLM 6X12 F	32,02	25

2 pieces required per joint

Height 85 mm
Nominal 3 3/8 inches

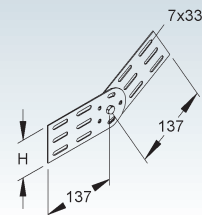

Splice/Link Kit

	Model no.	Height H	Width B	Acc. incl.	Weight per 100 pcs kg	Pack/Box Qty
		mm Inch	mm Inch			
S	RGE 85.100	85 3,3	100 3,9	2 SKM 8X16 V	78,59	1
S	RGE 85.200	85 3,3	200 7,9	2 SKM 8X16 V	88,87	1
S	RGE 85.300	85 3,3	300 11,8	2 SKM 8X16 V	99,15	1
S	RGE 85.400	85 3,3	400 15,7	2 SKM 8X16 V	109,43	1
S	RGE 85.500	85 3,3	500 19,7	2 SKM 8X16 V	119,71	1
S	RGE 85.600	85 3,3	600 23,6	2 SKM 8X16 V	129,99	1
F	RGE 85.100 F	85 3,3	100 3,9	2 SKM 8X16 F	86,11	1
F	RGE 85.200 F	85 3,3	200 7,9	2 SKM 8X16 F	97,41	1
F	RGE 85.300 F	85 3,3	300 11,8	2 SKM 8X16 F	108,72	1
F	RGE 85.400 F	85 3,3	400 15,7	2 SKM 8X16 F	120,03	1
F	RGE 85.500 F	85 3,3	500 19,7	2 SKM 8X16 F	131,34	1
F	RGE 85.600 F	85 3,3	600 23,6	2 SKM 8X16 F	142,65	1

for linking sections of tray with a vertical displacement

Height 85 mm
Nominal 3 3/8 inches

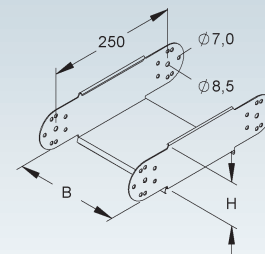

CABLE TRAY SYSTEM

Vertical Inside Elbow 45°

with integrated splice

	Model no.	Height H		Inside dimension B		Acc. incl.	Weight per 100 pcs kg	Pack/Box Qty
		mm	Inch	mm	Inch			
S	RSB 85.100	85	3,3	102	4	4 FLM 6X12	58,74	1
S	RSB 85.200	85	3,3	202	8	5 FLM 6X12	81,07	1
S	RSB 85.300	85	3,3	302	11,9	5 FLM 6X12	102,59	1
S	RSB 85.400	85	3,3	402	15,8	6 FLM 6X12	124,90	1
S	RSB 85.500	85	3,3	502	19,8	6 FLM 6X12	146,43	1
S	RSB 85.600	85	3,3	602	23,7	6 FLM 6X12	167,95	1

Height 85 mm
Nominal 3 3/8 inches

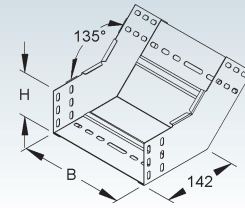

Vertical Inside Elbow 90°

with integrated splice

	Model no.	Height H		Inside dimension B		Acc. incl.	Weight per 100 pcs kg	Pack/Box Qty
		mm	Inch	mm	Inch			
S	RSD 85.100	85	3,3	102	4	4 FLM 6X12	90,07	1
S	RSD 85.200	85	3,3	202	8	5 FLM 6X12	125,37	1
S	RSD 85.300	85	3,3	302	11,9	5 FLM 6X12	159,75	1
S	RSD 85.400	85	3,3	402	15,8	6 FLM 6X12	195,05	1
S	RSD 85.500	85	3,3	502	19,8	6 FLM 6X12	229,43	1
S	RSD 85.600	85	3,3	602	23,7	6 FLM 6X12	263,81	1

Height 85 mm
Nominal 3 3/8 inches

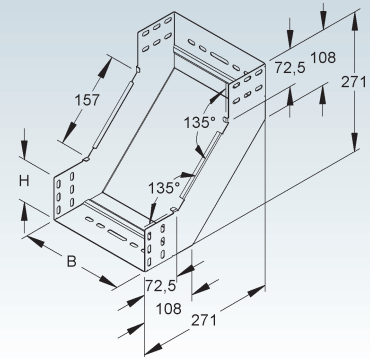

Vertical Outside Elbow 45°

with integrated splice

	Model no.	Height H		Inside dimension B		Acc. incl.	Weight per 100 pcs kg	Pack/Box Qty
		mm	Inch	mm	Inch			
S	RFB 85.100	85	3,3	102	4	4 FLM 6X12	47,54	1
S	RFB 85.200	85	3,3	202	8	5 FLM 6X12	62,80	1
S	RFB 85.300	85	3,3	302	11,9	5 FLM 6X12	77,27	1
S	RFB 85.400	85	3,3	402	15,8	6 FLM 6X12	92,52	1
S	RFB 85.500	85	3,3	502	19,8	6 FLM 6X12	106,98	1
S	RFB 85.600	85	3,3	602	23,7	6 FLM 6X12	121,44	1

Height 85 mm
Nominal 3 3/8 inches

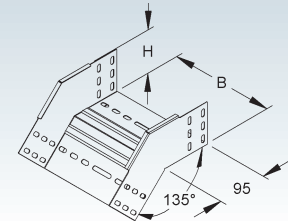

Vertical Outside Elbow 90°

with integrated splice

	Model no.	Height H		Inside dimension B		Acc. incl.	Weight per 100 pcs kg	Pack/Box Qty
		mm	Inch	mm	Inch			
S	RFD 85.100	85	3,3	102	4	4 FLM 6X12	88,27	1
S	RFD 85.200	85	3,3	202	8	5 FLM 6X12	115,75	1
S	RFD 85.300	85	3,3	302	11,9	5 FLM 6X12	142,43	1
S	RFD 85.400	85	3,3	402	15,8	6 FLM 6X12	169,90	1
S	RFD 85.500	85	3,3	502	19,8	6 FLM 6X12	196,59	1
S	RFD 85.600	85	3,3	602	23,7	6 FLM 6X12	223,27	1

Height 85 mm
Nominal 3 3/8 inches

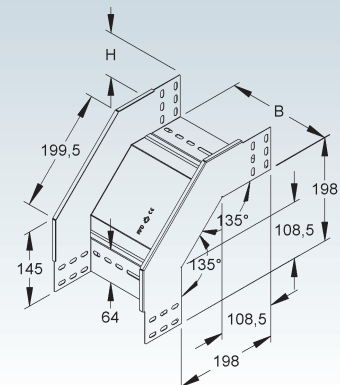

Vertical Tee Down, lengthwise

with integrated splice

	Model no.	Height H		Inside dimension B		Length A		Height H1	Acc. incl.	Weight per 100 pcs kg	Pack/Box Qty
		mm	Inch	mm	Inch	mm	Inch				
S	RTL 85.100	85	3,3	102	4	360	14,2	121	16 FLM 6X12	146,06	1
S	RTL 85.200	85	3,3	202	8	500	19,7	153	19 FLM 6X12	271,97	1
S	RTL 85.300	85	3,3	302	11,9	780	30,7	244	21 FLM 6X12	537,68	1
S	RTL 85.400	85	3,3	402	15,8	880	34,6	244	24 FLM 6X12	681,09	1
S	RTL 85.500	85	3,3	502	19,8	980	38,6	244	24 FLM 6X12	834,97	1
S	RTL 85.600	85	3,3	602	23,7	1080	42,5	244	24 FLM 6X12	1.010,70	1

Size of run and tap tray is identical.

Delivered as a kit (not assembled).

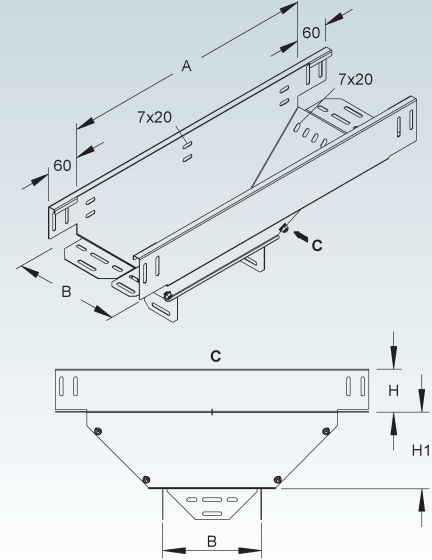
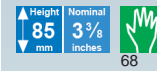

Vertical Tee Down, crosswise

with integrated splice

	Model no.	Height H		Inside dimension B		Length A	Acc. incl.	Weight per 100 pcs kg	Pack/Box Qty	
		mm	Inch	mm	Inch					
S	RTQ 85.100	85	3,3	102	4	336	13,2	8 FLM 6X12	122,19	1
S	RTQ 85.200	85	3,3	202	8	336	13,2	10 FLM 6X12	158,35	1
S	RTQ 85.300	85	3,3	302	11,9	336	13,2	10 FLM 6X12	192,91	1
S	RTQ 85.400	85	3,3	402	15,8	336	13,2	12 FLM 6X12	229,07	1
S	RTQ 85.500	85	3,3	502	19,8	336	13,2	12 FLM 6X12	263,63	1
S	RTQ 85.600	85	3,3	602	23,7	336	13,2	12 FLM 6X12	298,19	1

Size of run and tap tray is identical.

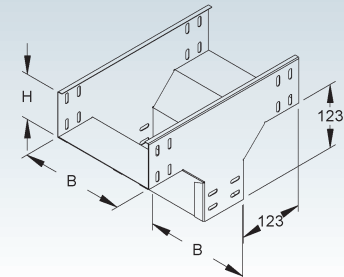

Edge Protection Plate

	Model no.	Width B		Acc. incl.	Weight per 100 pcs kg	Pack/Box Qty
		mm	Inch			
S	RKB 100	92	3,6	1 FLM 6X12	4,40	10
S	RKB 200	192	7,6	2 FLM 6X12	9,13	10
S	RKB 300	292	11,5	2 FLM 6X12	13,27	10
S	RKB 400	392	15,4	2 FLM 6X12	17,40	10
S	RKB 500	492	19,4	2 FLM 6X12	21,53	10
S	RKB 600	592	23,3	2 FLM 6X12	25,67	10
F	RKB 100 F	92	3,6	1 FLM 6X12 F	4,89	50
F	RKB 200 F	192	7,6	2 FLM 6X12 F	10,13	50
F	RKB 300 F	292	11,5	2 FLM 6X12 F	14,69	50
F	RKB 400 F	392	15,4	2 FLM 6X12 F	19,23	50
F	RKB 500 F	492	19,4	2 FLM 6X12 F	23,77	50
F	RKB 600 F	592	23,3	2 FLM 6X12 F	28,33	50

with rounded edges to protect cables at the joint and to reinforce the bottom of cable trays

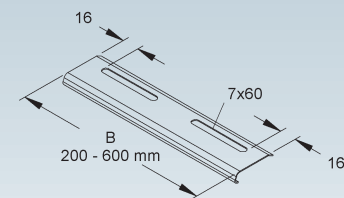

CABLE TRAY SYSTEM

Available Side Rail Heights

SYSTEM	Cable Tray	RLU...	Page 219
	Heavy Duty Cable Tray	RS...	Page 219
	Heavy Duty Cable Tray	RSU...	Page 220
	Distribution Cable Tray	RSV...	Page 220
ACCESSORIES	Edge Protection Ring	KSR 40 A	Page 220
	U-shaped Splice Plate	RV...	Page 221
	Three Piece Splice Plate Kit	RVV 110...	Page 221
	Splice Plate	RVV 110 E3	Page 221
	Universal Splice Plate	RSUV 110-1.5/200 S	Page 222
	Divider	RW 110...	Page 222
	Splice Plate for Divider	RTV 110 E2	Page 222
	Mounting Plate for Divider	RTPH 50	Page 222
	Mounting Plate for Divider with M6 Stud	RTPH 50 M6	Page 223
	Extension Horizontal Tee	RTA...	Page 223
	Horizontal Elbow Building Block	REK...	Page 223
	Flexible Horizontal Elbow 0-90°	RBAV...	Page 224
	Horizontal Elbow 45°	RBA...	Page 224
	Horizontal Elbow 90°	RES...	Page 224
	Horizontal Tee	RTS...	Page 225
	Horizontal Cross	RKS...	Page 225
	Reducer/Blind End	RA...	Page 225
	Adjustable Horizontal Splice/Reducer/Blind End	RAW...	Page 226
	Adjustable Vertical Splice Plate	RGV...	Page 226
	Splice/Link Kit	RGE...	Page 226
	Vertical Inside Elbow 45°	RSB...	Page 226
	Vertical Inside Elbow 90°	RSD...	Page 227
	Vertical Outside Elbow 45°	RFB...	Page 227
	Vertical Outside Elbow 90°	RFD...	Page 227
	Vertical Tee Down, lengthwise	RTL...	Page 228
	Vertical Tee Down, crosswise	RTQ...	Page 228
	Edge Protection Plate	RKB...	Page 228

See covers for cable trays and fittings on page 229 and following.



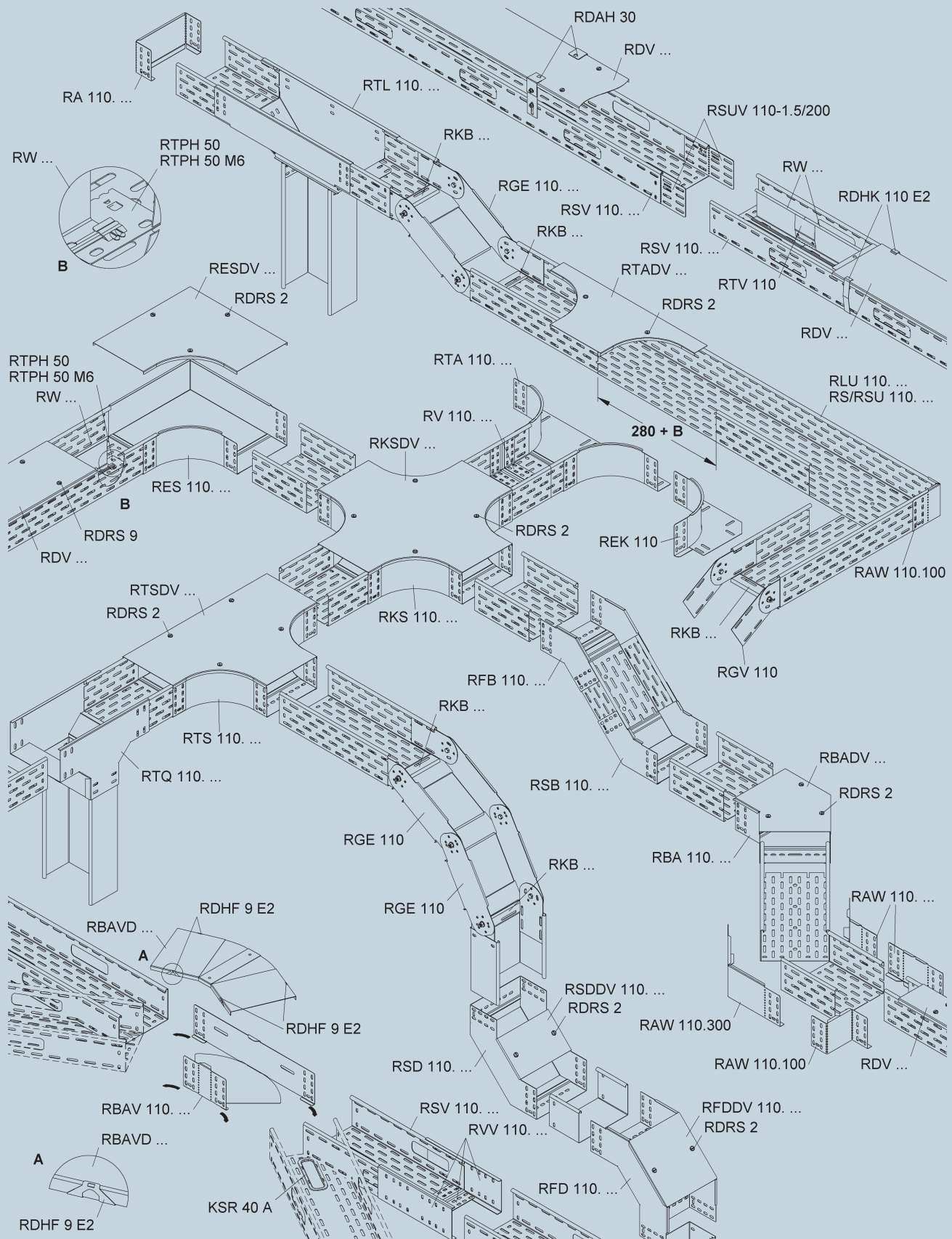

CABLE TRAY SYSTEM

Load/Span Class Designation in accordance with NEMA VE 1 and CSA C22.2 No. 126.1

Niedax Series	Minimum Area		Load class in accordance to NEMA VE 1		
	(calculational) mm ² / in. ²	in accordance to NEMA VE 2 mm ² / in. ²	Rated Load Kg/m / lb./ft.	Support spacing m / ft.	Load/Span Class
RLUX 110.100 E3	275 / 0.43	258 / 0.4	113 / 76	2 / 6.6	5A, A
RLUX 110.200 E3	355 / 0.55	258 / 0.4	113 / 76	2 / 6.6	5A, A
RLUX 110.300 E3	435 / 0.67	258 / 0.4	113 / 76	2 / 6.6	5A, A
RLUX 110.400 E3	580 / 0.90	452 / 0.7	113 / 76	2 / 6.6	5A, A
RSX 110.100, ... F	386 / 0.60	258 / 0.4	224 / 151	2 / 6.6	5A, C
RSX 110.200, ... F	494 / 0.77	452 / 0.7	224 / 151	2 / 6.6	5A, C
RSX 110.300, ... F	602 / 0.93	452 / 0.7	224 / 151	2 / 6.6	5A, C
RSX 110.400, ... F	710 / 1.10	645 / 1.0	224 / 151	2 / 6.6	5A, C
RSX 110.500, ... F	818 / 1.27	645 / 1.0	224 / 151	2 / 6.6	5A, C
RSX 110.600, ... F	930 / 1.44	645 / 1.0	224 / 151	2 / 6.6	5A, C
RSUX 110.100, ... F	512 / 0.79	452 / 0.7	224 / 151	2 / 6.6	5A, C
RSUX 110.200, ... F	662 / 1.03	645 / 1.0	224 / 151	2 / 6.6	5A, C
RSUX 110.300, ... F	812 / 1.26	645 / 1.0	224 / 151	2 / 6.6	5A, C
RSUX 110.400, ... F	961 / 1.49	645 / 1.0	224 / 151	2 / 6.6	5A, C
RSUX 110.500, ... F	1112 / 1.72	968 / 1.5	224 / 151	2 / 6.6	5A, C
RSUX 110.600, ... F	1266 / 1.96	968 / 1.5	224 / 151	2 / 6.6	5A, C
RSVX 110.100 S, ... F *	368 / 0.57	258 / 0.4	67 / 45	3 / 9.8	8A, A, 10AA
RSVX 110.150 S, ... F *	383 / 0.59	258 / 0.4	67 / 45	3 / 9.8	8A, A, 10AA
RSVX 110.200 S, ... F *	437 / 0.68	258 / 0.4	67 / 45	3 / 9.8	8A, A, 10AA
RSVX 110.300 S, ... F *	587 / 0.91	452 / 0.7	67 / 45	3 / 9.8	8A, A, 10AA
RSVX 110.400 S, ... F *	758 / 1.17	645 / 1.0	67 / 45	3 / 9.8	8A, A, 10AA

* - tested by UL with the three piece splice plate kit RVVX in the middle of two supports



Cable Tray

solid, but with splice plate perforation

Model no.	Height H		Width B		Thick-ness t	Acc. incl.	Weight per 100 m kg	Pack/Box Qty
	mm	Inch	mm	Inch				
E3 RLU 110.100 E3	110	4,3	100	3,9	0,8	8 FLM 6X12 E3	226,44	2 x 3 m
E3 RLU 110.200 E3	110	4,3	200	7,9	0,8	10 FLM 6X12 E3	292,25	2 x 3 m
E3 RLU 110.300 E3	110	4,3	300	11,8	0,8	10 FLM 6X12 E3	357,47	2 x 3 m
E3 RLU 110.400 E3	110	4,3	400	15,7	0,9	12 FLM 6X12 E3	473,84	2 x 3 m

One RV... splice plate included with every piece of cable tray.

Height 110 mm
Nominal 4 3/8 Inches

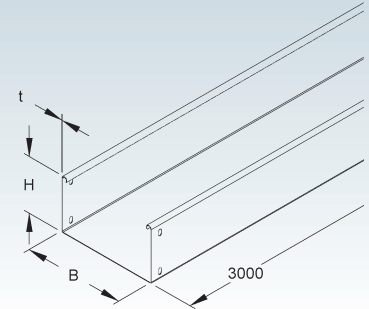

Heavy Duty Cable Tray

ventilated

Model no.	Height H		Width B		Thick-ness t	Acc. incl.	Weight per 100 m kg	Pack/Box Qty
	mm	Inch	mm	Inch				
S RS 110.100	110	4,3	100	3,9	1,5	8 FLM 6X12	350,29	2 x 3 m
S RS 110.200	110	4,3	200	7,9	1,5	10 FLM 6X12	451,10	2 x 3 m
S RS 110.300	110	4,3	300	11,8	1,5	10 FLM 6X12	551,39	2 x 3 m
S RS 110.400	110	4,3	400	15,7	1,5	12 FLM 6X12	652,20	2 x 3 m
S RS 110.500	110	4,3	500	19,7	1,5	12 FLM 6X12	752,48	2 x 3 m
S RS 110.600	110	4,3	600	23,6	1,5	12 FLM 6X12	852,76	2 x 3 m
F RS 110.100 F	110	4,3	100	3,9	1,5	8 FLM 6X12 F	385,11	2 x 3 m
F RS 110.200 F	110	4,3	200	7,9	1,5	10 FLM 6X12 F	495,95	2 x 3 m
F RS 110.300 F	110	4,3	300	11,8	1,5	10 FLM 6X12 F	606,26	2 x 3 m
F RS 110.400 F	110	4,3	400	15,7	1,5	12 FLM 6X12 F	717,10	2 x 3 m
F RS 110.500 F	110	4,3	500	19,7	1,5	12 FLM 6X12 F	827,42	2 x 3 m
F RS 110.600 F	110	4,3	600	23,6	1,5	12 FLM 6X12 F	937,72	2 x 3 m

Bottom plate and side rail perforated with staggered punch holes. Centered punchholes allow hanging with M10 (3/8") threaded rod.

One RV... splice plate included with every piece of cable tray.

Load Chart: q = uniformly distributed load (tested according to DIN EN IEC 61537 standard)

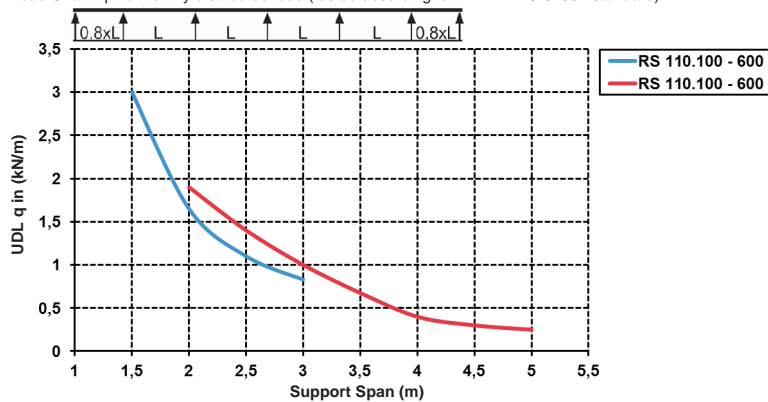

Load rating with heavy duty splice plate RVV... in red.

Load rating with splice plate RV... in blue.

Height 110 mm
Nominal 4 3/8 Inches

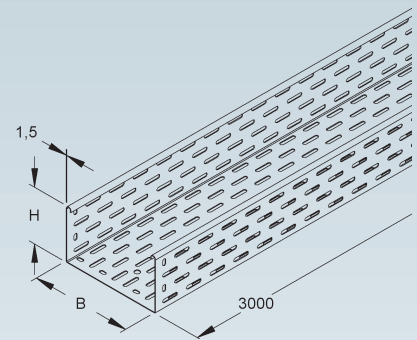

CABLE TRAY SYSTEM

Heavy Duty Cable Tray

solid, but with splice plate perforation

	Model no.	Height H		Width B		Thick-ness t mm	Acc. incl.	Weight per 100 m kg	Pack/ Box Qty
		mm	Inch	mm	Inch				
S	RSU 110.100	110	4,3	100	3,9	1,5	8 FLM 6X12	409,62	2 x 3 m
S	RSU 110.200	110	4,3	200	7,9	1,5	10 FLM 6X12	529,94	2 x 3 m
S	RSU 110.300	110	4,3	300	11,8	1,5	10 FLM 6X12	649,67	2 x 3 m
S	RSU 110.400	110	4,3	400	15,7	1,5	12 FLM 6X12	769,93	2 x 3 m
S	RSU 110.500	110	4,3	500	19,7	1,5	12 FLM 6X12	889,73	2 x 3 m
S	RSU 110.600	110	4,3	600	23,6	1,5	12 FLM 6X12	1.009,52	2 x 3 m
F	RSU 110.100 F	110	4,3	100	3,9	1,5	8 FLM 6X12 F	450,63	2 x 3 m
F	RSU 110.200 F	110	4,3	200	7,9	1,5	10 FLM 6X12 F	583,01	2 x 3 m
F	RSU 110.300 F	110	4,3	300	11,8	1,5	10 FLM 6X12 F	714,76	2 x 3 m
F	RSU 110.400 F	110	4,3	400	15,7	1,5	12 FLM 6X12 F	847,03	2 x 3 m
F	RSU 110.500 F	110	4,3	500	19,7	1,5	12 FLM 6X12 F	978,81	2 x 3 m
F	RSU 110.600 F	110	4,3	600	23,6	1,5	12 FLM 6X12 F	1.111,18	2 x 3 m

One RV... splice plate included with every piece of cable tray.

Height 110 mm
Nominal 4 3/8 inches

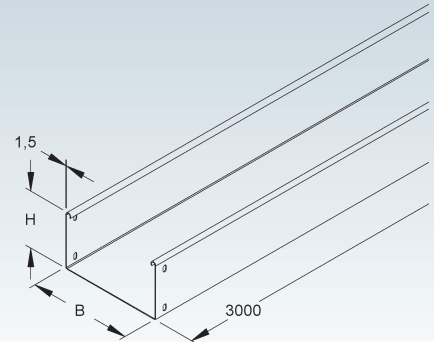

Distribution Cable Tray

ventilated

	Model no.	Height H		Width B		Thick-ness t mm	Acc. incl.	Weight per 100 m kg	Pack/ Box Qty
		mm	Inch	mm	Inch				
S	RSV 110.100 S	110	4,3	100	3,9	1,5	12 FLM 6X12	333,57	2 x 3 m
S	RSV 110.150 S	110	4,3	150	5,9	1,5	12 FLM 6X12	383,71	2 x 3 m
S	RSV 110.200 S	110	4,3	200	7,9	1,5	12 FLM 6X12	433,86	2 x 3 m
S	RSV 110.300 S	110	4,3	300	11,8	1,5	12 FLM 6X12	537,38	2 x 3 m
S	RSV 110.400 S	110	4,3	400	15,7	1,5	12 FLM 6X12	647,36	2 x 3 m
F	RSV 110.100 F	110	4,3	100	3,9	1,5	12 FLM 6X12 F	366,62	2 x 3 m
F	RSV 110.150 F	110	4,3	150	5,9	1,5	12 FLM 6X12 F	421,77	2 x 3 m
F	RSV 110.200 F	110	4,3	200	7,9	1,5	12 FLM 6X12 F	476,93	2 x 3 m
F	RSV 110.300 F	110	4,3	300	11,8	1,5	12 FLM 6X12 F	590,81	2 x 3 m
F	RSV 110.400 F	110	4,3	400	15,7	1,5	12 FLM 6X12 F	711,78	2 x 3 m

Hole pattern may vary based on width of tray.

Multiple cable drop outs are punched into the bottom part and the flange of tray.

One RV... splice plate included with every piece of cable tray.

Load Chart: q = uniformly distributed load (tested according to DIN EN IEC 61537 standard)

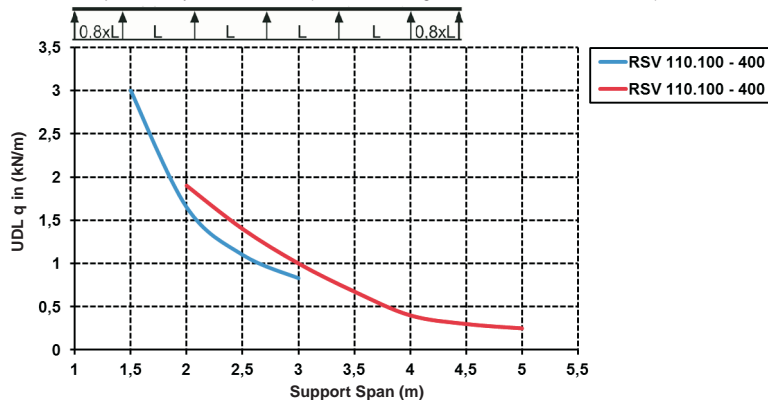

Load rating with heavy duty splice plate RVV... in red.
Load rating with splice plate RV... in blue.

Height 110 mm
Nominal 4 3/8 inches



51

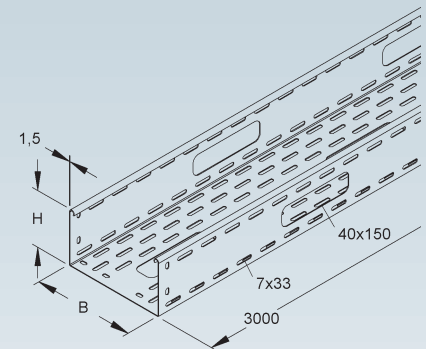

Edge Protection Ring

UV resistant

	Model no.	Color	Inside height H		Inside dimension B		Weight per 100 pcs kg	Pack/ Box Qty
			mm	Inch	mm	Inch		
K04	KSR 40 A	black	34,5	1,4	144,5	5,7	0,97	20

to protect cables at the knockouts

Suitable for: distribution cable trays RLCPV 85... and RSV 110...

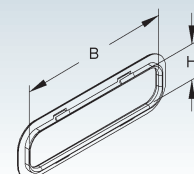

U-Shaped Splice Plate

	Model no.	Height H		Width B		Acc. incl.	Weight per 100 pcs kg	Pack/Box Qty
		mm	Inch	mm	Inch			
S	RV 110.100	98	3,9	97	3,8	8 FLM 6X12	23,77	1
S	RV 110.200	98	3,9	197	7,8	10 FLM 6X12	31,48	1
S	RV 110.300	98	3,9	297	11,7	10 FLM 6X12	37,62	1
S	RV 110.400	98	3,9	397	15,6	12 FLM 6X12	45,34	1
S	RV 110.500	98	3,9	497	19,6	12 FLM 6X12	51,47	1
S	RV 110.600	98	3,9	597	23,5	12 FLM 6X12	57,61	1
F	RV 110.100 F	98	3,9	97	3,8	8 FLM 6X12 F	25,51	1
F	RV 110.150 F	98	3,9	147	5,8	8 FLM 6X12 F	28,88	1
F	RV 110.200 F	98	3,9	197	7,8	10 FLM 6X12 F	33,84	1
F	RV 110.300 F	98	3,9	297	11,7	10 FLM 6X12 F	40,59	1
F	RV 110.400 F	98	3,9	397	15,6	12 FLM 6X12 F	48,93	1
F	RV 110.500 F	98	3,9	497	19,6	12 FLM 6X12 F	55,67	1
F	RV 110.600 F	98	3,9	597	23,5	12 FLM 6X12 F	62,42	1
E3	RV 110.100 E3	98	3,9	97	3,8	8 FLM 6X12 E3	24,11	1
E3	RV 110.200 E3	98	3,9	197	7,8	10 FLM 6X12 E3	31,92	1
E3	RV 110.300 E3	98	3,9	297	11,7	10 FLM 6X12 E3	38,10	1
E3	RV 110.400 E3	98	3,9	397	15,6	12 FLM 6X12 E3	45,91	1
E3	RV 110.500 E3	98	3,9	497	19,6	12 FLM 6X12 E3	52,09	1
E3	RV 110.600 E3	98	3,9	597	23,5	12 FLM 6X12 E3	58,26	1

Suitable for: cable trays RLU..., RS..., RSU... and RSV...

Height
110 mm
Nominal
4 3/8 inches

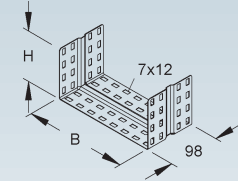

RL 110 ...
RLU 110 ...
RS 110 ...
RSU 110 ...
RSV 110 ...

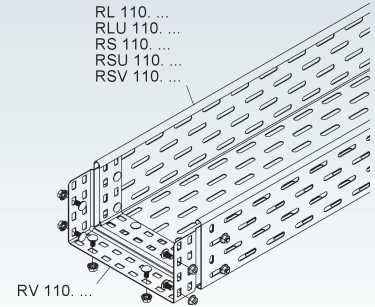

Three Piece Splice Plate Kit

	Model no.	Height H		Width B		Acc. incl.	Weight per 100 pcs kg	Pack/Box Qty
		mm	Inch	mm	Inch			
S	RVV 110.100	111	4,4	100	3,9	12 FLM 6X12	112,36	5
S	RVV 110.150	111	4,4	150	5,9	12 FLM 6X12	115,83	5
S	RVV 110.200	111	4,4	200	7,9	12 FLM 6X12	119,30	5
S	RVV 110.300	111	4,4	300	11,8	12 FLM 6X12	126,24	5
S	RVV 110.400	111	4,4	400	15,7	12 FLM 6X12	133,18	5
S	RVV 110.500	111	4,4	500	19,7	12 FLM 6X12	140,12	5
S	RVV 110.600	111	4,4	600	23,6	12 FLM 6X12	147,06	5
F	RVV 110.100 F	111	4,4	100	3,9	12 FLM 6X12 F	124,14	5
F	RVV 110.150 F	111	4,4	150	5,9	12 FLM 6X12 F	127,95	5
F	RVV 110.200 F	111	4,4	200	7,9	12 FLM 6X12 F	131,77	5
F	RVV 110.300 F	111	4,4	300	11,8	12 FLM 6X12 F	139,40	5
F	RVV 110.400 F	111	4,4	400	15,7	12 FLM 6X12 F	147,04	5
F	RVV 110.500 F	111	4,4	500	19,7	12 FLM 6X12 F	154,67	5
F	RVV 110.600 F	111	4,4	600	23,6	12 FLM 6X12 F	162,31	5

heavy duty splice kit to extend support span

Suitable for: extending support span of RS.../RSV 110... tray up to 5 meters

Height
110 mm
Nominal
4 3/8 inches

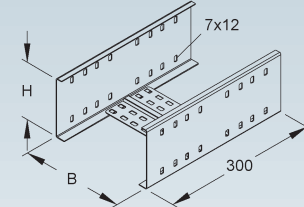

RS 110 ...
RSV 110 ...

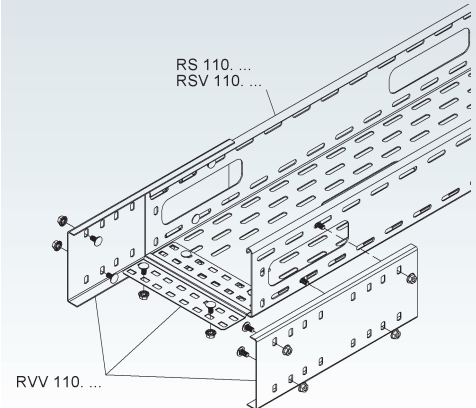

Splice Plate

	Model no.	Height H		Acc. incl.	Weight per 100 pcs kg	Pack/Box Qty
		mm	Inch			
E3	RVV 110 E3	111	4,4	4 FLM 6X12 E3	51,18	10

heavy duty splice kit to extend support span

2 pieces required per joint

Height
110 mm
Nominal
4 3/8 inches

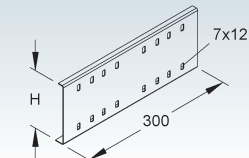

CABLE TRAY SYSTEM

Universal Splice Plate

	Model no.	Height H		Width B		Thick-ness t	Acc. incl.	Weight per 100 pcs kg	Pack/Box Qty
		mm	Inch	mm	Inch				
S	RSUV 110-1.5/200 S	102	4	200	7,9	1,5	4 FLM 6X12	22,75	50

for straight and angled joints

2 pieces required per joint

Height 110 mm
Nominal 4 3/8 inches

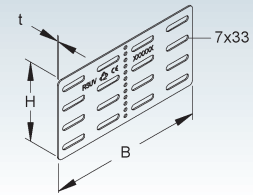

Divider

	Model no.	Height H		Thick-ness t	Acc. incl.	Weight per 100 m kg	Pack/Box Qty
		mm	Inch				
S	RW 110	98	3,9	0,9	4 FLM 6X12	90,29	10 x 3 m
F	RW 110 F	98	3,9	0,9	4 FLM 6X12 F	99,21	10 x 3 m
E3	RW 110 E3	98	3,9	0,9	4 FLM 6X12 E3	90,88	10 x 3 m

to separate wires and cables of different voltage levels or with different functions

Height 110 mm
Nominal 4 3/8 inches



69

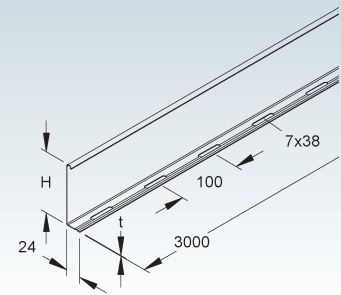

Splice Plate for Divider

	Model no.	Height H		Length L		Weight per 100 pcs kg	Pack/Box Qty
		mm	Inch	mm	Inch		
E2	RTV 110 E2	97,5	3,8	80	3,1	2,5	20

for positive locking connections and proper bonding of dividers

Height 110 mm
Nominal 4 3/8 inches



69

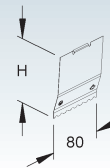

Mounting Plate for Divider

	Model no.	Length L		Width B		Thick-ness t	Weight per 100 pcs kg	Pack/Box Qty
		mm	Inch	mm	Inch			
S	RTPH 50	83	3,3	59	2,3	0,9	3,36	20

Mounting plate with locking mechanism for fast installation of dividers in ventilated cable tray series RL.../RS... series (min. width 100 mm) and ventilated cable trays series RLCI 60... / RLCPV 85... (min. width 200 mm).

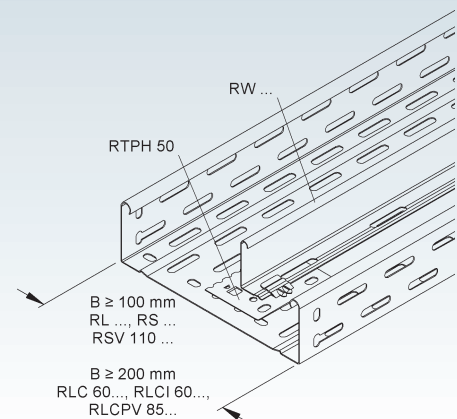
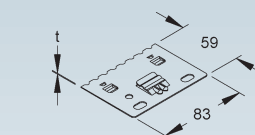

Mounting Plate for Divider with M6 Stud

Model no.	Length L		Width B		Thickness t	Acc. incl.	Weight per 100 pcs kg	Pack/Box Qty
	mm	Inch	mm	Inch				
S RTPH 50 M6	83	3,3	59	2,3	0,9	1 SMF6	3,98	50

Mounting plate with locking mechanism for fast installation of dividers in ventilated cable tray series RL.../RS... series (min. width 100 mm) and ventilated cable trays series RLCI 60... / RLCPV 85... (min. width 200 mm). With M6 locking stud.

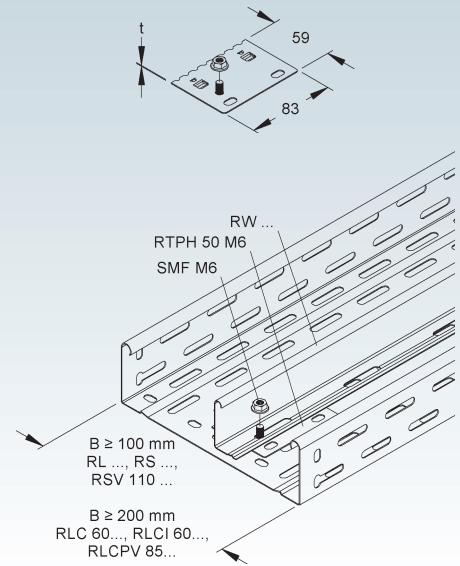

Extension Horizontal Tee

with integrated splice

Model no.	Height H		Inside dimension B		Acc. incl.	Weight per 100 pcs kg	Pack/Box Qty
	mm	Inch	mm	Inch			
S RTA 110.100	110	4,3	102	4	10 FLM 6X12	106,56	1
S RTA 110.150	110	4,3	152	6	10 FLM 6X12	115,02	1
S RTA 110.200	110	4,3	202	8	10 FLM 6X12	123,48	1
S RTA 110.300	110	4,3	302	11,9	10 FLM 6X12	140,40	1
S RTA 110.400	110	4,3	402	15,8	10 FLM 6X12	157,60	1
S RTA 110.500	110	4,3	502	19,8	10 FLM 6X12	174,06	1
S RTA 110.600	110	4,3	602	23,7	10 FLM 6X12	192,18	1
F RTA 110.100 F	110	4,3	102	4	10 FLM 6X12 F	117,42	1
F RTA 110.150 F	110	4,3	152	6	10 FLM 6X12 F	126,72	1
F RTA 110.200 F	110	4,3	202	8	10 FLM 6X12 F	136,03	1
F RTA 110.300 F	110	4,3	302	11,9	10 FLM 6X12 F	154,64	1
F RTA 110.400 F	110	4,3	402	15,8	10 FLM 6X12 F	173,56	1
F RTA 110.500 F	110	4,3	502	19,8	10 FLM 6X12 F	191,67	1
F RTA 110.600 F	110	4,3	602	23,7	10 FLM 6X12 F	211,85	1
E3 RTA 110.100 E3	110	4,3	102	4	10 FLM 6X12 E3	98,25	1
E3 RTA 110.200 E3	110	4,3	202	8	10 FLM 6X12 E3	113,34	1
E3 RTA 110.300 E3	110	4,3	302	11,9	10 FLM 6X12 E3	128,48	1
E3 RTA 110.400 E3	110	4,3	402	15,8	10 FLM 6X12 E3	163,15	1
E3 RTA 110.500 E3	110	4,3	502	19,8	10 FLM 6X12 E3	181,62	1
E3 RTA 110.600 E3	110	4,3	602	23,7	10 FLM 6X12 E3	200,54	1

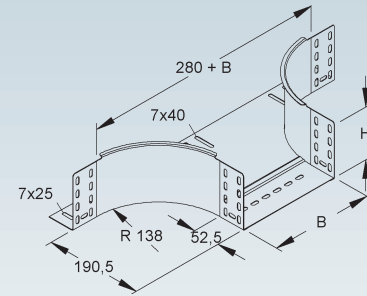
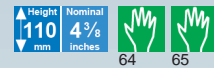

Horizontal Elbow Building Block

with integrated splice

Model no.	Height H		Acc. incl.	Weight per 100 pcs kg	Pack/Box Qty
	mm	Inch			
S REK 110	110	4,3	6 FLM 6X12	51,84	1
F REK 110 F	110	4,3	6 FLM 6X12 F	57,14	1
E3 REK 110 E3	110	4,3	6 FLM 6X12 E3	47,88	1

for building customized horizontal cable tray fittings

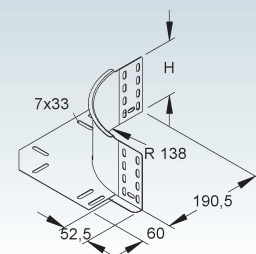
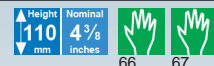

CABLE TRAY SYSTEM

Flexible Horizontal Elbow 0-90°

with integrated splice

	Model no.	Height H		Inside dimension B		Acc. incl.	Weight per 100 pcs kg	Pack/Box Qty
		mm	Inch	mm	Inch			
S	RBAV 110.100	110	4,3	100	3,9	10 FLM 6X12	63,79	1
S	RBAV 110.150	110	4,3	150	5,9	10 FLM 6X12	80,92	1
S	RBAV 110.200	110	4,3	200	7,9	10 FLM 6X12	98,85	1
S	RBAV 110.300	110	4,3	300	11,8	10 FLM 6X12	147,40	1
S	RBAV 110.400	110	4,3	400	15,7	10 FLM 6X12	205,26	1
S	RBAV 110.500	110	4,3	500	19,7	14 FLM 6X12	282,04	1
S	RBAV 110.600	110	4,3	600	23,6	14 FLM 6X12	366,80	1

Height 110 mm
Nominal 4 3/8 inches

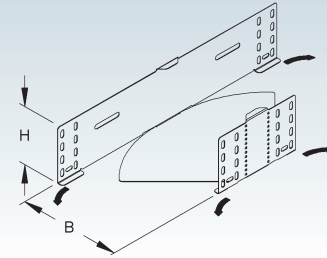

Horizontal Elbow 45°

with integrated splice

	Model no.	Height H		Inside dimension B		Acc. incl.	Weight per 100 pcs kg	Pack/Box Qty
		mm	Inch	mm	Inch			
S	RBA 110.100	110	4,3	102	4	4 FLM 6X12	63,30	1
S	RBA 110.150	110	4,3	152	6	4 FLM 6X12	79,30	1
S	RBA 110.200	110	4,3	202	8	5 FLM 6X12	96,90	1
S	RBA 110.300	110	4,3	302	11,9	5 FLM 6X12	137,00	1
S	RBA 110.400	110	4,3	402	15,8	6 FLM 6X12	183,80	1
S	RBA 110.500	110	4,3	502	19,8	6 FLM 6X12	236,90	1
S	RBA 110.600	110	4,3	602	23,7	6 FLM 6X12	300,12	1
F	RBA 110.100 F	110	4,3	102	4	4 FLM 6X12 F	72,94	1
F	RBA 110.150 F	110	4,3	152	6	4 FLM 6X12 F	85,20	1
F	RBA 110.200 F	110	4,3	202	8	5 FLM 6X12 F	111,33	1
F	RBA 110.300 F	110	4,3	302	11,9	5 FLM 6X12 F	155,18	1
F	RBA 110.400 F	110	4,3	402	15,8	6 FLM 6X12 F	207,49	1
F	RBA 110.500 F	110	4,3	502	19,8	6 FLM 6X12 F	265,65	1
F	RBA 110.600 F	110	4,3	602	23,7	6 FLM 6X12 F	331,19	1

Height 110 mm
Nominal 4 3/8 inches

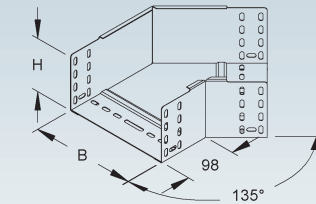

Horizontal Elbow 90°

with integrated splice

	Model no.	Height H		Inside dimension B		Acc. incl.	Weight per 100 pcs kg	Pack/Box Qty
		mm	Inch	mm	Inch			
S	RES 110.100	110	4,3	102	4	4 FLM 6X12	130,87	1
S	RES 110.150	110	4,3	152	6	4 FLM 6X12	163,59	1
S	RES 110.200	110	4,3	202	8	5 FLM 6X12	210,10	1
S	RES 110.300	110	4,3	302	11,9	5 FLM 6X12	300,12	1
S	RES 110.400	110	4,3	402	15,8	6 FLM 6X12	406,21	1
S	RES 110.500	110	4,3	502	19,8	6 FLM 6X12	527,62	1
S	RES 110.600	110	4,3	602	23,7	6 FLM 6X12	664,74	1
F	RES 110.100 F	110	4,3	102	4	4 FLM 6X12 F	144,04	1
F	RES 110.150 F	110	4,3	152	6	4 FLM 6X12 F	180,03	1
F	RES 110.200 F	110	4,3	202	8	5 FLM 6X12 F	231,21	1
F	RES 110.300 F	110	4,3	302	11,9	5 FLM 6X12 F	330,23	1
F	RES 110.400 F	110	4,3	402	15,8	6 FLM 6X12 F	446,95	1
F	RES 110.500 F	110	4,3	502	19,8	6 FLM 6X12 F	580,50	1
F	RES 110.600 F	110	4,3	602	23,7	6 FLM 6X12 F	731,33	1

Height 110 mm
Nominal 4 3/8 inches

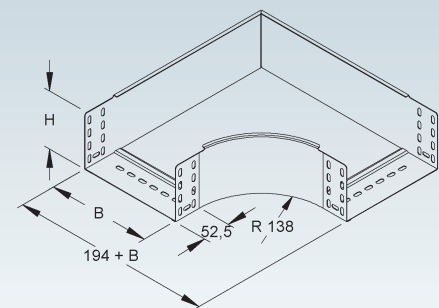

Horizontal Tee

with integrated splice

Model no.		Height H	Inside dimension B	Acc. incl.	Weight per 100 pcs kg	Pack/Box Qty
		mm Inch	mm Inch			
S	RTS 110.100	110 4,3	102 4	8 FLM 6X12	171,34	1
S	RTS 110.150	110 4,3	152 6	8 FLM 6X12	205,51	1
S	RTS 110.200	110 4,3	202 8	10 FLM 6X12	257,52	1
S	RTS 110.300	110 4,3	302 11,9	10 FLM 6X12	351,91	1
S	RTS 110.400	110 4,3	402 15,8	12 FLM 6X12	463,60	1
S	RTS 110.500	110 4,3	502 19,8	12 FLM 6X12	589,39	1
S	RTS 110.600	110 4,3	602 23,7	12 FLM 6X12	732,32	1
F	RTS 110.100 F	110 4,3	102 4	8 FLM 6X12 F	188,63	1
F	RTS 110.150 F	110 4,3	152 6	8 FLM 6X12 F	226,22	1
F	RTS 110.200 F	110 4,3	202 8	10 FLM 6X12 F	283,47	1
F	RTS 110.300 F	110 4,3	302 11,9	10 FLM 6X12 F	387,30	1
F	RTS 110.400 F	110 4,3	402 15,8	12 FLM 6X12 F	510,20	1
F	RTS 110.500 F	110 4,3	502 19,8	12 FLM 6X12 F	648,57	1
F	RTS 110.600 F	110 4,3	602 23,7	12 FLM 6X12 F	804,21	1

Height Nominal
110 mm 4 3/8 inches

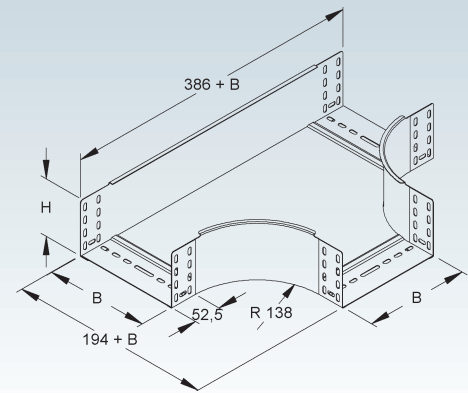

Horizontal Cross

with integrated splice

Model no.		Height H	Inside dimension B	Acc. incl.	Weight per 100 pcs kg	Pack/Box Qty
		mm Inch	mm Inch			
S	RKS 110.100	110 4,3	102 4	12 FLM 6X12	216,46	1
S	RKS 110.150	110 4,3	152 6	12 FLM 6X12	256,03	1
S	RKS 110.200	110 4,3	202 8	15 FLM 6X12	301,93	1
S	RKS 110.300	110 4,3	302 11,9	15 FLM 6X12	400,69	1
S	RKS 110.400	110 4,3	402 15,8	18 FLM 6X12	517,56	1
S	RKS 110.500	110 4,3	502 19,8	18 FLM 6X12	647,72	1
S	RKS 110.600	110 4,3	602 23,7	18 FLM 6X12	797,59	1
F	RKS 110.100 F	110 4,3	102 4	12 FLM 6X12 F	238,35	1
F	RKS 110.150 F	110 4,3	152 6	12 FLM 6X12 F	281,87	1
F	RKS 110.200 F	110 4,3	202 8	15 FLM 6X12 F	332,42	1
F	RKS 110.300 F	110 4,3	302 11,9	15 FLM 6X12 F	441,06	1
F	RKS 110.400 F	110 4,3	402 15,8	18 FLM 6X12 F	569,68	1
F	RKS 110.500 F	110 4,3	502 19,8	18 FLM 6X12 F	712,85	1
F	RKS 110.600 F	110 4,3	602 23,7	18 FLM 6X12 F	878,25	1

Height Nominal
110 mm 4 3/8 inches

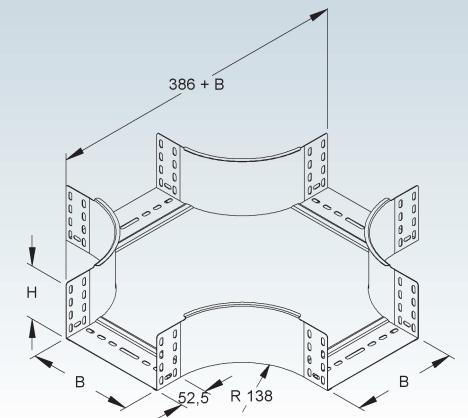

Reducer/Blind End

Model no.		Height H	Width B	Width B1	Acc. incl.	Weight per 100 pcs kg	Pack/Box Qty
		mm Inch	mm Inch	mm Inch			
S	RA 110.050	110 4,3	50 2	172 6,8	4 FLM 6X12	18,64	20
S	RA 110.150	110 4,3	150 5,9	272 10,7	4 FLM 6X12	29,14	20
S	RA 110.200	110 4,3	200 7,9	322 12,7	4 FLM 6X12	34,39	20
S	RA 110.350	110 4,3	350 13,8	472 18,6	4 FLM 6X12	50,13	20
S	RA 110.400	110 4,3	400 15,7	522 20,6	4 FLM 6X12	55,38	20
S	RA 110.500	110 4,3	500 19,7	622 24,5	4 FLM 6X12	65,87	20
S	RA 110.600	110 4,3	600 23,6	722 28,4	4 FLM 6X12	76,37	20
F	RA 110.050 F	110 4,3	50 2	172 6,8	4 FLM 6X12 F	20,68	1
F	RA 110.150 F	110 4,3	150 5,9	272 10,7	4 FLM 6X12 F	32,23	1
F	RA 110.200 F	110 4,3	200 7,9	322 12,7	4 FLM 6X12 F	38,01	1
F	RA 110.350 F	110 4,3	350 13,8	472 18,6	4 FLM 6X12 F	55,32	1
F	RA 110.400 F	110 4,3	400 15,7	522 20,6	4 FLM 6X12 F	61,10	1
F	RA 110.500 F	110 4,3	500 19,7	622 24,5	4 FLM 6X12 F	72,64	1
F	RA 110.600 F	110 4,3	600 23,6	722 28,4	4 FLM 6X12 F	84,19	1
E3	RA 110.050 E3	110 4,3	50 2	172 6,8	4 FLM 6X12 E3	17,30	20
E3	RA 110.200 E3	110 4,3	200 7,9	322 12,7	4 FLM 6X12 E3	31,58	20
E3	RA 110.400 E3	110 4,3	400 15,7	522 20,6	4 FLM 6X12 E3	50,63	20
E3	RA 110.500 E3	110 4,3	500 19,7	622 24,5	4 FLM 6X12 E3	60,15	20
E3	RA 110.600 E3	110 4,3	600 23,6	722 28,4	4 FLM 6X12 E3	69,68	20

Height Nominal
110 mm 4 3/8 inches

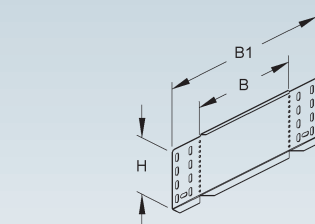

can be used as blind end or as reducer for cable trays

CABLE TRAY SYSTEM

Adjustable Horizontal Splice/Reducer/Blind End

	Model no.	Height H		Width B		Width B1	Acc. incl.	Weight per 100 pcs kg	Pack/Box Qty	
		mm	Inch	mm	Inch					mm
S	RAW 110.100	110	4,3	100	3,9	222	8,7	4 FLM 6X12	23,60	20
S	RAW 110.300	110	4,3	300	11,8	422	16,6	4 FLM 6X12	44,59	20
F	RAW 110.100 F	110	4,3	100	3,9	222	8,7	4 FLM 6X12 F	26,14	1
F	RAW 110.300 F	110	4,3	300	11,8	422	16,6	4 FLM 6X12 F	49,23	1
E3	RAW 110.100 E3	110	4,3	100	3,9	222	8,7	4 FLM 6X12 E3	21,36	20
E3	RAW 110.300 E3	110	4,3	300	11,8	422	16,6	4 FLM 6X12 E3	40,41	20

can be used as blind end or as reducer for cable trays

Height 110 mm
Nominal 4 3/8 inches

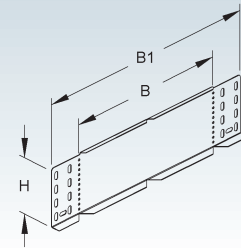

Adjustable Vertical Splice Plate

	Model no.	Height H		Acc. incl.	Weight per 100 pcs kg	Pack/Box Qty
		mm	Inch			
S	RGV 110	93	3,7	4 FLM 6X12	40,99	25
F	RGV 110 F	93	3,7	4 FLM 6X12 F	44,51	25
E3	RGV 110 E3	93	3,7	4 FLM 6X12 E3	28,98	25

2 pieces required per joint

Height 110 mm
Nominal 4 3/8 inches

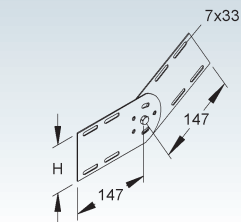

Splice/Link Kit

	Model no.	Height H		Width B		Acc. incl.	Weight per 100 pcs kg	Pack/Box Qty
		mm	Inch	mm	Inch			
S	RGE 110.100	110	4,3	100	3,9	2 SKM 8X16 V	97,55	1
S	RGE 110.150	110	4,3	150	5,9	2 SKM 8X16 V	102,69	1
S	RGE 110.200	110	4,3	200	7,9	2 SKM 8X16 V	107,83	1
S	RGE 110.300	110	4,3	300	11,8	2 SKM 8X16 V	118,11	1
S	RGE 110.400	110	4,3	400	15,7	2 SKM 8X16 V	128,39	1
S	RGE 110.500	110	4,3	500	19,7	2 SKM 8X16 V	138,67	1
S	RGE 110.600	110	4,3	600	23,6	2 SKM 8X16 V	148,94	1
F	RGE 110.100 F	110	4,3	100	3,9	2 SKM 8X16 F	106,96	1
F	RGE 110.150 F	110	4,3	150	5,9	2 SKM 8X16 F	112,62	1
F	RGE 110.200 F	110	4,3	200	7,9	2 SKM 8X16 F	118,27	1
F	RGE 110.300 F	110	4,3	300	11,8	2 SKM 8X16 F	129,58	1
F	RGE 110.400 F	110	4,3	400	15,7	2 SKM 8X16 F	140,89	1
F	RGE 110.500 F	110	4,3	500	19,7	2 SKM 8X16 F	152,19	1
F	RGE 110.600 F	110	4,3	600	23,6	2 SKM 8X16 F	163,49	1

for linking sections of tray with a vertical displacement

Height 110 mm
Nominal 4 3/8 inches

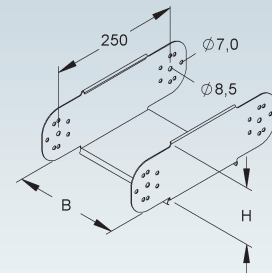

Vertical Inside Elbow 45°

with integrated splice

	Model no.	Height H		Inside dimension B	Acc. incl.	Weight per 100 pcs kg	Pack/Box Qty	
		mm	Inch					mm
S	RSB 110.100	110	4,3	102	4	4 FLM 6X12	64,86	1
S	RSB 110.150	110	4,3	152	6	4 FLM 6X12	75,62	1
S	RSB 110.200	110	4,3	202	8	5 FLM 6X12	87,18	1
S	RSB 110.300	110	4,3	302	11,9	5 FLM 6X12	108,70	1
S	RSB 110.400	110	4,3	402	15,8	6 FLM 6X12	131,02	1
S	RSB 110.500	110	4,3	502	19,8	6 FLM 6X12	152,54	1
S	RSB 110.600	110	4,3	602	23,7	6 FLM 6X12	174,06	1

Height 110 mm
Nominal 4 3/8 inches

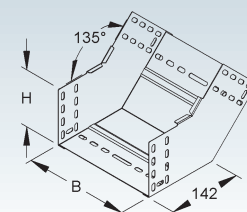

Vertical Inside Elbow 90°

with integrated splice

	Model no.	Height H		Inside dimension B		Acc. incl.	Weight per 100 pcs kg	Pack/Box Qty
		mm	Inch	mm	Inch			
S	RSD 110.100	110	4,3	102	4	4 FLM 6X12	100,16	1
S	RSD 110.150	110	4,3	152	6	4 FLM 6X12	117,35	1
S	RSD 110.200	110	4,3	202	8	5 FLM 6X12	135,46	1
S	RSD 110.300	110	4,3	302	11,9	5 FLM 6X12	169,84	1
S	RSD 110.400	110	4,3	402	15,8	6 FLM 6X12	205,14	1
S	RSD 110.500	110	4,3	502	19,8	6 FLM 6X12	239,52	1
S	RSD 110.600	110	4,3	602	23,7	6 FLM 6X12	273,90	1

Height 110 mm
Nominal 4 3/8 inches

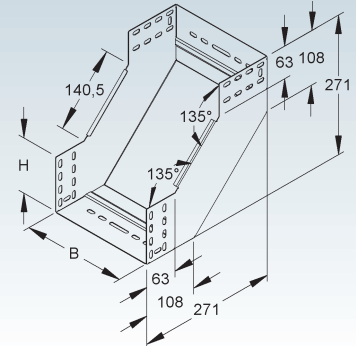

Vertical Outside Elbow 45°

with integrated splice

	Model no.	Height H		Inside dimension B		Acc. incl.	Weight per 100 pcs kg	Pack/Box Qty
		mm	Inch	mm	Inch			
S	RFB 110.100	110	4,3	102	4	4 FLM 6X12	56,53	1
S	RFB 110.150	110	4,3	152	6	4 FLM 6X12	63,76	1
S	RFB 110.200	110	4,3	202	8	5 FLM 6X12	71,79	1
S	RFB 110.300	110	4,3	302	11,9	5 FLM 6X12	86,25	1
S	RFB 110.400	110	4,3	402	15,8	6 FLM 6X12	101,50	1
S	RFB 110.500	110	4,3	502	19,8	6 FLM 6X12	115,97	1
S	RFB 110.600	110	4,3	602	23,7	6 FLM 6X12	130,43	1

Height 110 mm
Nominal 4 3/8 inches

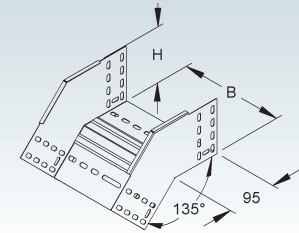

Vertical Outside Elbow 90°

with integrated splice

	Model no.	Height H		Inside dimension B		Acc. incl.	Weight per 100 pcs kg	Pack/Box Qty
		mm	Inch	mm	Inch			
S	RFD 110.100	110	4,3	102	4	4 FLM 6X12	105,85	1
S	RFD 110.150	110	4,3	152	6	4 FLM 6X12	119,19	1
S	RFD 110.200	110	4,3	202	8	5 FLM 6X12	133,33	1
S	RFD 110.300	110	4,3	302	11,9	5 FLM 6X12	160,02	1
S	RFD 110.400	110	4,3	402	15,8	6 FLM 6X12	187,49	1
S	RFD 110.500	110	4,3	502	19,8	6 FLM 6X12	214,17	1
S	RFD 110.600	110	4,3	602	23,7	6 FLM 6X12	240,85	1

Height 110 mm
Nominal 4 3/8 inches

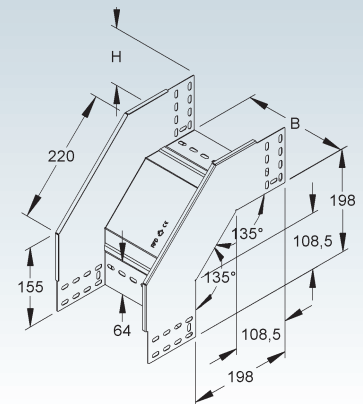

CABLE TRAY SYSTEM

Vertical Tee Down, lengthwise

with integrated splice

	Model no.	Height H		Inside dimension B		Length A		Height H1	Acc. incl.	Weight per 100 pcs kg	Pack/ Box Qty
		mm	Inch	mm	Inch	mm	Inch				
S	RTL 110.150	110	4,3	152	6	330	13	93	16 FLM 6X12	187,06	1
S	RTL 110.200	110	4,3	202	8	430	16,9	118	19 FLM 6X12	264,54	1
S	RTL 110.300	110	4,3	302	11,9	630	24,8	168	21 FLM 6X12	446,99	1
S	RTL 110.400	110	4,3	402	15,8	730	28,7	168	24 FLM 6X12	575,62	1
S	RTL 110.500	110	4,3	502	19,8	830	32,7	168	24 FLM 6X12	712,49	1
S	RTL 110.600	110	4,3	602	23,7	930	36,6	168	24 FLM 6X12	868,26	1

Size of run and tap tray is identical.
Delivered as a kit (not assembled).

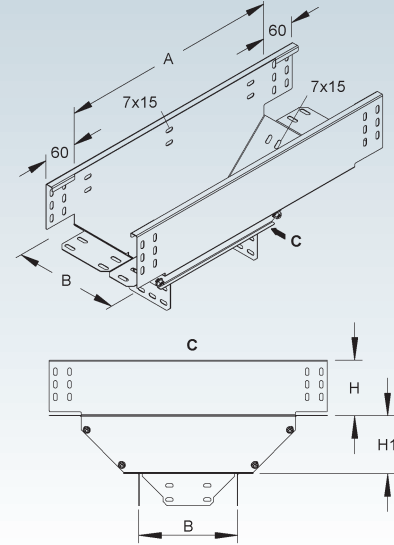
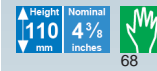

Vertical Tee Down, crosswise

with integrated splice

	Model no.	Height H		Inside dimension B		Length A		Acc. incl.	Weight per 100 pcs kg	Pack/ Box Qty
		mm	Inch	mm	Inch	mm	Inch			
S	RTQ 110.100	110	4,3	102	4	361	14,2	8 FLM 6X12	144,98	1
S	RTQ 110.150	110	4,3	152	6	361	14,2	8 FLM 6X12	162,26	1
S	RTQ 110.200	110	4,3	202	8	361	14,2	10 FLM 6X12	181,14	1
S	RTQ 110.300	110	4,3	302	11,9	361	14,2	10 FLM 6X12	215,70	1
S	RTQ 110.400	110	4,3	402	15,8	361	14,2	12 FLM 6X12	251,86	1
S	RTQ 110.500	110	4,3	502	19,8	361	14,2	12 FLM 6X12	286,42	1
S	RTQ 110.600	110	4,3	602	23,7	361	14,2	12 FLM 6X12	322,42	1

Size of run and tap tray is identical.

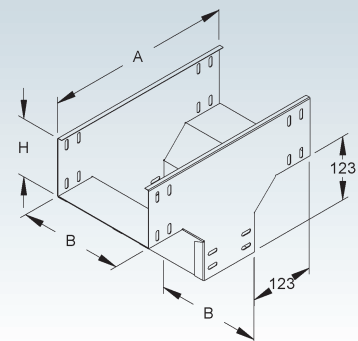

Edge Protection Plate

	Model no.	Width B		Acc. incl.	Weight per 100 pcs kg	Pack/ Box Qty
		mm	Inch			
S	RKB 100	92	3,6	1 FLM 6X12	4,40	10
S	RKB 150	142	5,6	2 FLM 6X12	7,15	10
S	RKB 200	192	7,6	2 FLM 6X12	9,13	10
S	RKB 300	292	11,5	2 FLM 6X12	13,27	10
S	RKB 400	392	15,4	2 FLM 6X12	17,40	10
S	RKB 500	492	19,4	2 FLM 6X12	21,53	10
S	RKB 600	592	23,3	2 FLM 6X12	25,67	10
F	RKB 100 F	92	3,6	1 FLM 6X12 F	4,89	50
F	RKB 150 F	142	5,6	2 FLM 6X12 F	7,96	50
F	RKB 200 F	192	7,6	2 FLM 6X12 F	10,13	50
F	RKB 300 F	292	11,5	2 FLM 6X12 F	14,69	50
F	RKB 400 F	392	15,4	2 FLM 6X12 F	19,23	50
F	RKB 500 F	492	19,4	2 FLM 6X12 F	23,77	50
F	RKB 600 F	592	23,3	2 FLM 6X12 F	28,33	50
E3	RKB 100 E3	92	3,6	1 FLM 6X12 E3	4,43	10
E3	RKB 200 E3	192	7,6	2 FLM 6X12 E3	9,20	10
E3	RKB 300 E3	292	11,5	2 FLM 6X12 E3	13,36	10
E3	RKB 400 E3	392	15,4	2 FLM 6X12 E3	17,52	10
E3	RKB 500 E3	492	19,4	2 FLM 6X12 E3	21,68	10
E3	RKB 600 E3	592	23,3	2 FLM 6X12 E3	25,84	10

with rounded edges to protect cables at the joint and to reinforce the bottom of cable trays

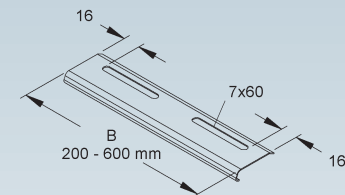

Cover for Cable Tray/Ladder

with turnbolt locks

Model no.		Inside dimension B	Weight per 100 m	Pack/Box Qty
		mm Inch	kg	
S	RDV 100	102 4	74,17	2 x 3 m
S	RDV 150	152 6	103,81	2 x 3 m
S	RDV 200	202 8	133,44	2 x 3 m
S	RDV 300	302 11,9	231,02	2 x 3 m
S	RDV 400	402 15,8	335,56	2 x 3 m
S	RDV 500	502 19,8	414,60	2 x 3 m
S	RDV 600	602 23,7	493,63	2 x 3 m
F	RDV 100 F	102 4	81,59	2 x 3 m
F	RDV 150 F	152 6	114,19	2 x 3 m
F	RDV 200 F	202 8	146,79	2 x 3 m
F	RDV 300 F	302 11,9	254,13	2 x 3 m
F	RDV 400 F	402 15,8	369,12	2 x 3 m
F	RDV 500 F	502 19,8	456,06	2 x 3 m
F	RDV 600 F	602 23,7	542,99	2 x 3 m
E3	RDV 100 E3	102 4	80,01	2 x 3 m
E3	RDV 200 E3	202 8	143,64	2 x 3 m
E3	RDV 300 E3	302 11,9	207,26	2 x 3 m
E3	RDV 400 E3	402 15,8	269,62	2 x 3 m
E3	RDV 500 E3	502 19,8	376,11	2 x 3 m
E3	RDV 600 E3	602 23,7	447,70	2 x 3 m

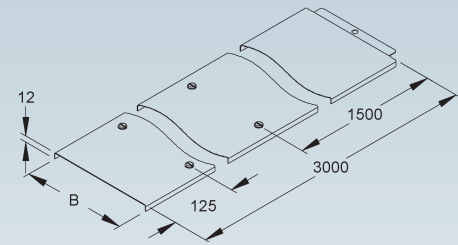

Suitable for: all straight sections of cable tray (other than RSV 50...) as well as for cable ladders KL...
For outdoor service covers need to be secured against windloads using heavy duty cover clamps or steel cable ties.

Cover for Horizontal Extension Tee

with turnbolt locks

Model no.		Inside dimension B	Weight per 100 pcs	Pack/Box Qty
		mm Inch	kg	
S	RTADV 100	104 4,1	43,37	1
S	RTADV 150	154 6,1	51,99	1
S	RTADV 200	204 8	60,61	1
S	RTADV 300	304 12	77,85	1
S	RTADV 400	404 15,9	95,09	1
S	RTADV 500	504 19,8	112,32	1
S	RTADV 600	604 23,8	129,56	1
F	RTADV 100 F	104 4,1	52,44	1
F	RTADV 150 F	154 6,1	57,97	1
F	RTADV 200 F	204 8	67,45	1
F	RTADV 300 F	304 12	86,42	1
F	RTADV 400 F	404 15,9	105,37	1
F	RTADV 500 F	504 19,8	124,33	1
F	RTADV 600 F	604 23,8	143,29	1
E3	RTADV 100 E3	104 4,1	39,61	1
E3	RTADV 200 E3	204 8	55,03	1
E3	RTADV 300 E3	304 12	70,45	1
E3	RTADV 400 E3	404 15,9	106,91	1
E3	RTADV 500 E3	504 19,8	126,19	1
E3	RTADV 600 E3	604 23,8	145,47	1

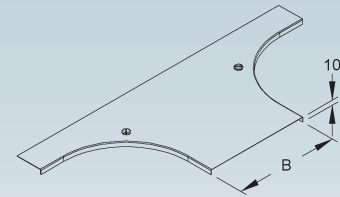

Suitable for: extension horizontal tee RTA...

For outdoor service covers need to be secured against windloads using heavy duty cover clamps or steel cable ties.

CABLE TRAY SYSTEM COVERS

Cover for Flexible Horizontal Fitting

	Model no.	Inside dimension B mm Inch	Weight per 100 pcs kg	Pack/Box Qty
S	RBAVD 100	102 4	32,22	1
S	RBAVD 150	152 6	60,75	1
S	RBAVD 200	202 8	97,66	1
S	RBAVD 300	302 11,9	197,83	1
S	RBAVD 400	402 15,8	332,19	1
S	RBAVD 500	502 19,8	501,43	1
S	RBAVD 600	602 23,7	704,80	1

adjustable from 0-90°

Suitable for: flexible horizontal elbow RBAV...

RDHF 9 E2 cover clamps shall not be used when covers are installed vertically.

4 x RDHF 9 E2 cover clips required per cover. Please order separately.

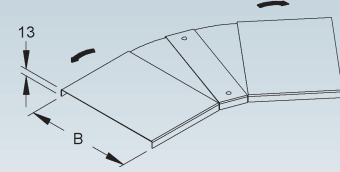

Cover for 45° Horizontal Elbow

with turnbolt locks

	Model no.	Inside dimension B mm Inch	Weight per 100 pcs kg	Pack/Box Qty
S	RBADV 100	104 4,1	24,99	1
S	RBADV 150	154 6,1	37,29	1
S	RBADV 200	204 8	51,21	1
S	RBADV 300	304 12	83,94	1
S	RBADV 400	404 15,9	123,17	1
S	RBADV 500	504 19,8	168,90	1
S	RBADV 600	604 23,8	221,13	1
F	RBADV 100 F	104 4,1	28,71	1
F	RBADV 150 F	154 6,1	42,24	1
F	RBADV 200 F	204 8	57,55	1
F	RBADV 300 F	304 12	93,54	1
F	RBADV 400 F	404 15,9	136,70	1
F	RBADV 500 F	504 19,8	187,00	1
F	RBADV 600 F	604 23,8	244,46	1

Suitable for: horizontal elbow 45° RBA...

For outdoor service covers need to be secured against windloads using heavy duty cover clamps or steel cable ties.

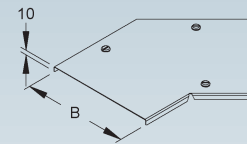

Cover for 90° Horizontal Elbow

with turnbolt locks

	Model no.	Inside dimension B mm Inch	Weight per 100 pcs kg	Pack/Box Qty
S	RESDV 100	104 4,1	39,00	1
S	RESDV 150	154 6,1	69,62	1
S	RESDV 200	204 8	96,39	1
S	RESDV 300	304 12	160,52	1
S	RESDV 400	404 15,9	238,78	1
S	RESDV 500	504 19,8	367,73	1
S	RESDV 600	604 23,8	486,08	1
F	RESDV 100 F	104 4,1	44,10	1
F	RESDV 150 F	154 6,1	77,79	1
F	RESDV 200 F	204 8	107,23	1
F	RESDV 300 F	304 12	177,78	1
F	RESDV 400 F	404 15,9	263,87	1
F	RESDV 500 F	504 19,8	405,71	1
F	RESDV 600 F	604 23,8	535,91	1
E3	RESDV 100 E3	104 4,1	42,80	1
E3	RESDV 200 E3	204 8	87,54	1
E3	RESDV 300 E3	304 12	144,91	1
E3	RESDV 400 E3	404 15,9	267,85	1
E3	RESDV 500 E3	504 19,8	371,16	1
E3	RESDV 600 E3	604 23,8	490,27	1

Suitable for: horizontal 90° elbow RES...

For outdoor service covers need to be secured against windloads using heavy duty cover clamps or steel cable ties.

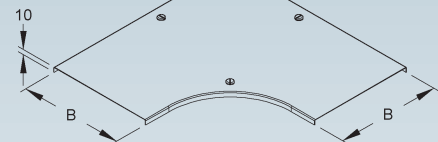

Cover for Horizontal Tee

with turnbolt locks

Model no.		Inside dimension B mm Inch	Weight per 100 pcs kg	Pack/Box Qty
S	RTSDV 100	104 4,1	72,24	1
S	RTSDV 150	154 6,1	105,14	1
S	RTSDV 200	204 8	141,97	1
S	RTSDV 300	304 12	227,41	1
S	RTSDV 400	404 15,9	328,54	1
S	RTSDV 500	504 19,8	445,38	1
S	RTSDV 600	604 23,8	577,92	1
F	RTSDV 100 F	104 4,1	81,08	1
F	RTSDV 150 F	154 6,1	117,30	1
F	RTSDV 200 F	204 8	157,82	1
F	RTSDV 300 F	304 12	251,90	1
F	RTSDV 400 F	404 15,9	363,04	1
F	RTSDV 500 F	504 19,8	491,56	1
F	RTSDV 600 F	604 23,8	637,35	1

Suitable for: horizontal tee RTS...

For outdoor service covers need to be secured against windloads using heavy duty cover clamps or steel cable ties.

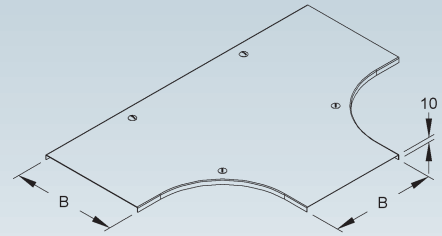

Cover for Horizontal Cross

with turnbolt locks

Model no.		Inside dimension B mm Inch	Weight per 100 pcs kg	Pack/Box Qty
S	RKSDV 100	104 4,1	95,41	1
S	RKSDV 150	154 6,1	135,44	1
S	RKSDV 200	204 8	179,40	1
S	RKSDV 300	304 12	279,10	1
S	RKSDV 400	404 15,9	394,49	1
S	RKSDV 500	504 19,8	525,59	1
S	RKSDV 600	604 23,8	672,38	1
F	RKSDV 100 F	104 4,1	106,57	1
F	RKSDV 150 F	154 6,1	150,60	1
F	RKSDV 200 F	204 8	198,96	1
F	RKSDV 300 F	304 12	308,63	1
F	RKSDV 400 F	404 15,9	435,56	1
F	RKSDV 500 F	504 19,8	579,77	1
F	RKSDV 600 F	604 23,8	741,24	1

Suitable for: horizontal cross RKS...

For outdoor service covers need to be secured against windloads using heavy duty cover clamps or steel cable ties.

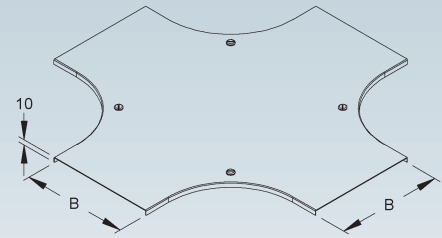

Cover for Vertical Inside/Outside Elbow Kit

with turnbolt locks

Model no.		Inside dimension B mm Inch	Weight per 100 pcs kg	Pack/Box Qty
S	RFSDDV 60.100	104 4,1	19,31	1
S	RFSDDV 60.150	154 6,1	24,99	1
S	RFSDDV 60.200	204 8	32,00	1
S	RFSDDV 60.300	304 12	46,00	1
S	RFSDDV 60.400	404 15,9	60,70	1
S	RFSDDV 60.500	504 19,8	73,90	1
S	RFSDDV 60.600	604 23,8	87,90	1

Suitable for: vertical inside/outside elbow kit with a side rail height of 60 mm, RFD 60... and RSD 60...

For outdoor service covers need to be secured against windloads using heavy duty cover clamps or steel cable ties.

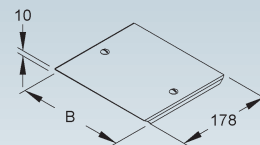

CABLE TRAY SYSTEM COVERS

Cover for Vertical Outside Elbow Kit

with turnbolt locks

	Model no.	Inside dimension B		Weight per 100 pcs kg	Pack/Box Qty
		mm	Inch		
S	RFDDV 85.100	104	4,1	20,7	1
S	RFDDV 85.200	204	8	36,4	1
S	RFDDV 85.300	304	12	52,1	1
S	RFDDV 85.400	404	15,9	67,8	1
S	RFDDV 85.500	504	19,8	83,5	1
S	RFDDV 85.600	604	23,8	99,2	1

Suitable for: vertical inside/outside elbow kit with a side rail height of 85 mm, RFD 85...

For outdoor service covers need to be secured against windloads using heavy duty cover clamps or steel cable ties.

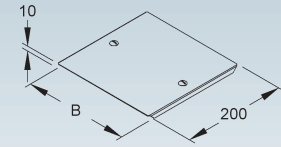

Cover for Vertical Outside Elbow Kit

with turnbolt locks

	Model no.	Inside dimension B		Weight per 100 pcs kg	Pack/Box Qty
		mm	Inch		
S	RFDDV 110.100	104	4,1	22,60	1
S	RFDDV 110.150	154	6,1	31,20	1
S	RFDDV 110.200	204	8	39,31	1
S	RFDDV 110.300	304	12	57,10	1
S	RFDDV 110.400	404	15,9	74,40	1
S	RFDDV 110.500	504	19,8	91,70	1
S	RFDDV 110.600	604	23,8	108,90	1

Suitable for: vertical inside/outside elbow kit with a side rail height of 110 mm, RFD 110...

For outdoor service covers need to be secured against windloads using heavy duty cover clamps or steel cable ties.

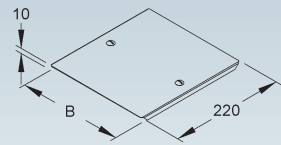

Cover for Vertical Inside Elbow

with turnbolt locks

	Model no.	Inside dimension B		Weight per 100 pcs kg	Pack/Box Qty
		mm	Inch		
S	RSDDV 85.100	104	4,1	16,25	1
S	RSDDV 85.200	204	8	28,49	1
S	RSDDV 85.300	304	12	40,74	1
S	RSDDV 85.400	404	15,9	52,99	1
S	RSDDV 85.500	504	19,8	65,23	1
S	RSDDV 85.600	604	23,8	77,48	1

Suitable for: cable tray vertical inside/outside elbow for side rail height of 85 mm, RSD 85...

For outdoor service covers need to be secured against windloads using heavy duty cover clamps or steel cable ties.

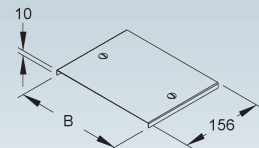

Cover for Vertical Inside Elbow

with turnbolt locks

	Model no.	Inside dimension B		Weight per 100 pcs kg	Pack/Box Qty
		mm	Inch		
S	RSDDV 110.100	104	4,1	14,23	1
S	RSDDV 110.150	154	6,1	19,52	1
S	RSDDV 110.200	204	8	24,82	1
S	RSDDV 110.300	304	12	35,42	1
S	RSDDV 110.400	404	15,9	46,02	1
S	RSDDV 110.500	504	19,8	56,62	1
S	RSDDV 110.600	604	23,8	67,21	1

Suitable for: cable tray vertical inside/outside elbow for side rail height of 110 mm, RSD 110 ...

For outdoor service covers need to be secured against windloads using heavy duty cover clamps or steel cable ties.

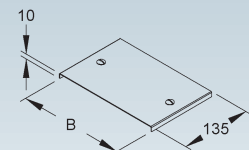

Turnbolt Lock

incl. locking nut

Model no.	Acc. incl.	Weight per 100 pcs kg	Pack/Box Qty
S RDRS 9	1 FL 6X12-S V, 1 SMS 6 V	1,2	100
F RDRS 9 F	1 FL 6X12-S E3, 1 SMS 6 E3	1,6	100
E3 RDRS 9 E3	1 FL 6X12-S E3, 1 SMS 6 E3	1,6	100

for field modifications of covers

Suitable for: cover RDV...

Please maintain a 50 mm minimum distance from the edge of the cover for the turn-bolt installation. Not sufficient for securing covers to tray installed vertically or sideways nor for securing covers against windloads. Please use self tapping screws, steel cable ties or coverhinges in addition.

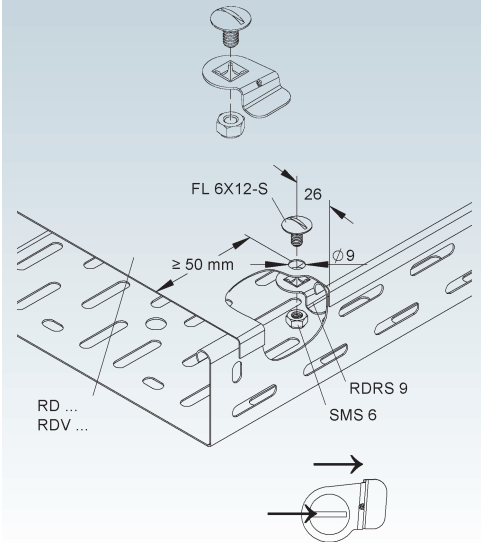

Turnbolt Lock

incl. locking nut

Model no.	Acc. incl.	Weight per 100 pcs kg	Pack/Box Qty
S RDRS 2	1 FL 6X12-S V, 1 SMS 6 V	1,3	100
E3 RDRS 2 E3	1 FL 6X12-S E3, 1 SMS 6 E3	1,5	100

Suitable for: all R-series fitting covers and RSV 50.100 distribution tray covers

Please maintain a 50 mm minimum distance from the edge of the cover for the turn-bolt installation. Not sufficient for securing covers to tray installed vertically or sideways nor for securing covers against windloads. Please use self tapping screws, steel cable ties or coverhinges in addition.

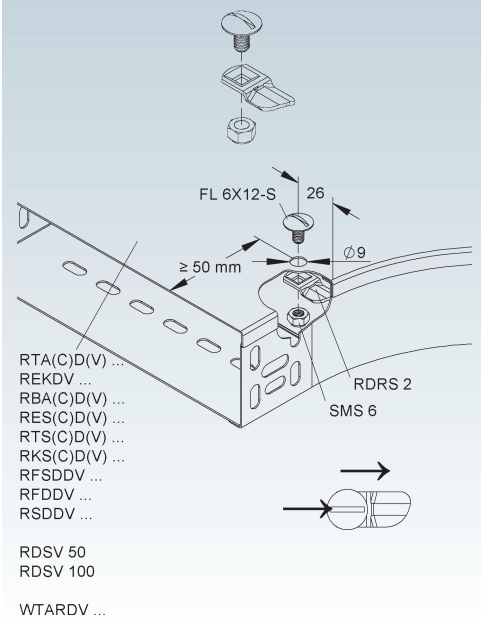

Exterior Cover Clamp

Model no.	Height H mm Inch	Weight per 100 pcs kg	Pack/Box Qty
E2 RDHK 60 E2	58 2,3	2,0	50
E2 RDHK 110 E2	108 4,3	2,2	50

Suitable for: all tray and fitting covers in 60 mm or 110 mm height

Please maintain a 50 mm minimum distance from the edge of the cover for the cover clamp installation.

Not sufficient for securing covers to tray installed vertically or sideways nor for securing covers against windloads. Please use self tapping screws, steel cable ties or coverhinges in addition.

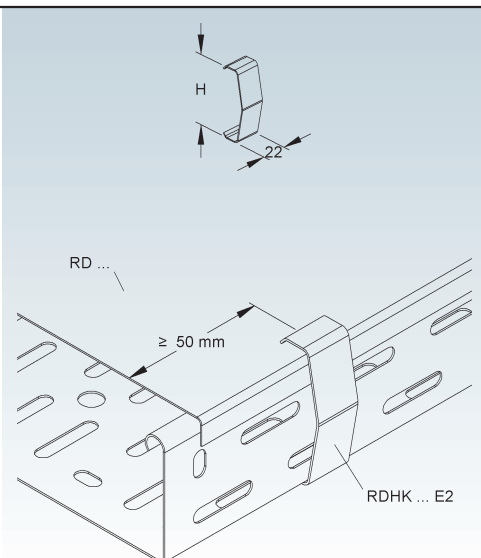

CABLE TRAY SYSTEM COVERS

Cover Clamp

Model no.	Weight per 100 pcs kg	Pack/Box Qty
E2 RDHF 9 E2	0,47	60

Suitable for: covers RDV... and RBAVD...

Please maintain a 50 mm minimum distance from the edge of the cover for the cover clamp installation.

Not sufficient for securing covers to tray installed vertically or sideways nor for securing covers against windloads. Please use self tapping screws, steel cable ties or coverhinges in addition.

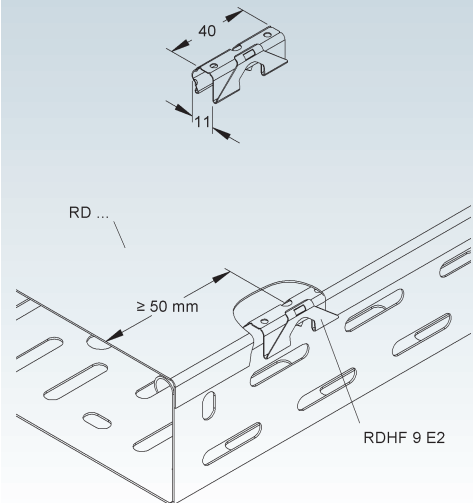

Raised Cover Clamp

spacer block with hold down bracket

Model no.	Height H mm Inch	Width B mm Inch	Thickness t mm	Acc. incl.	Weight per 100 pcs kg	Pack/Box Qty
S RDAH 30 S	122,5 4,8	40 1,6	1,5	2 FLM 6X12, 2 FLM 8X16 F	16,32	10
E3 RDAH 30 E3	122,5 4,8	40 1,6	1,5	2 FLM 6X12 E3, 2 FLM 8X16 E3	16,22	10

to elevate RD- and WDV-series covers for improved ventilation can be installed on all R-Series cable trays and all KL/WSL/WRL-series cable ladders with a minimum side rail height of 50 mm

Three pairs required for every 3-meter section of covers.

Suitable for: ventilated RL/RS cable trays, KL ladders, and WRL/WSL cable trays & ladders

Six cover clamps are required for any 3-meter piece of cover.

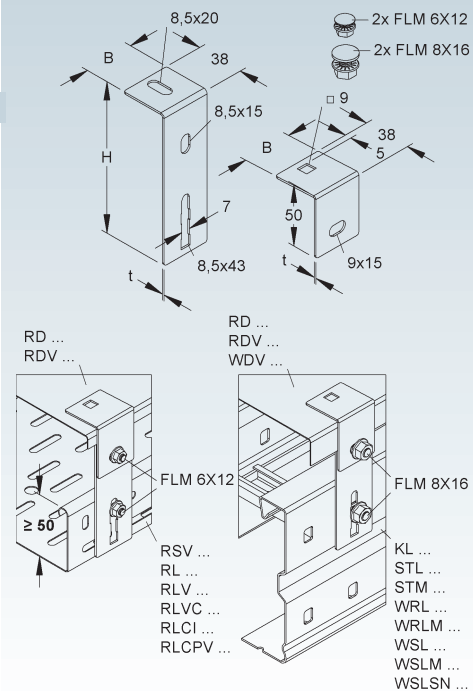
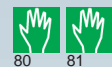

NOTES

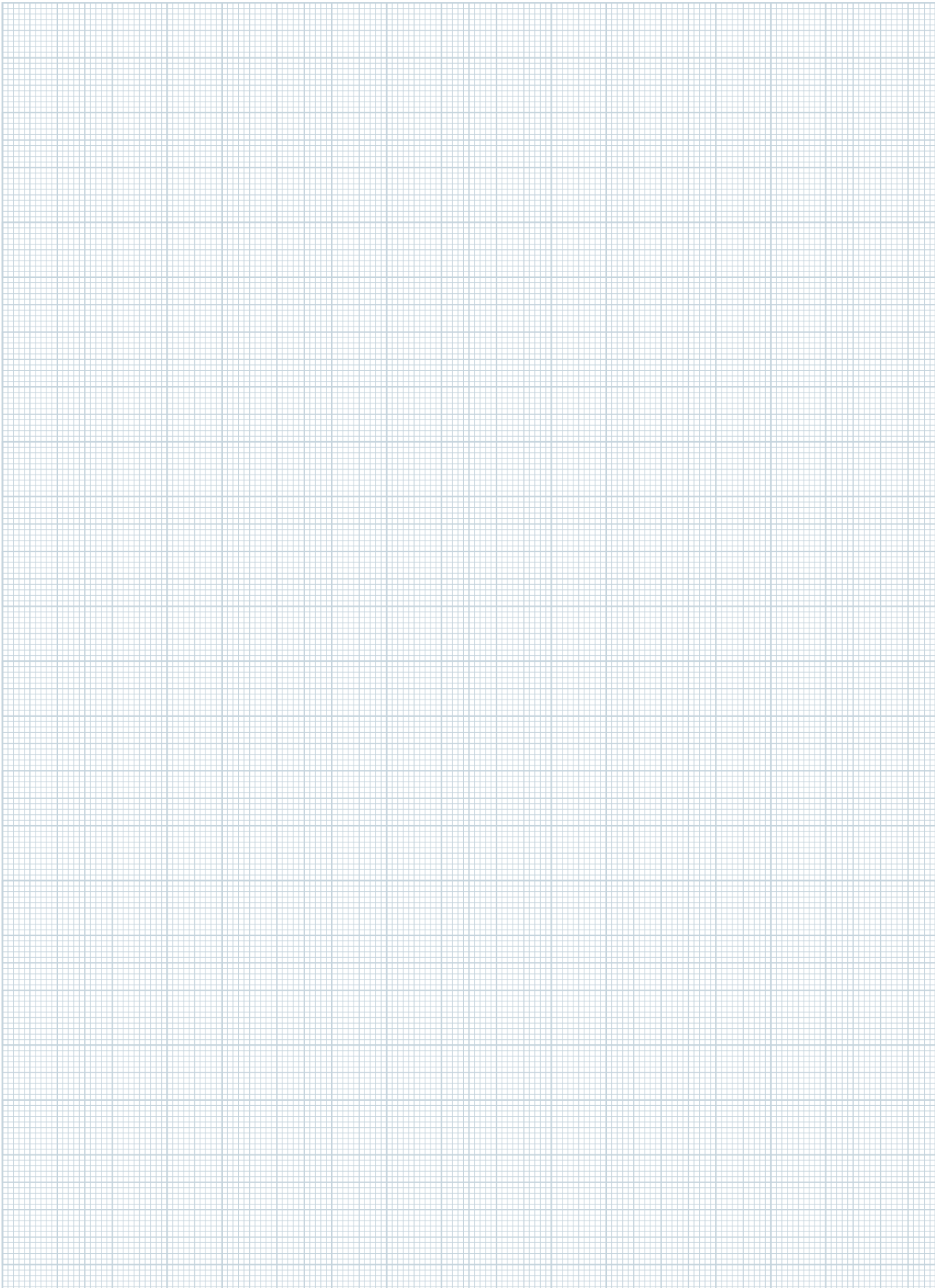

CABLE TRAY SYSTEM





FLOOR-MOUNT CABLE TRAY

- Floor-Mount Cable Tray
- Dividers
- Fittings
- Covers
- Accessories

Niedax cable trays are the perfect solution for routing and protecting control, signal, and power cables. The extra heavy-duty version with sturdy covers was designed to meet the stringent requirements of the automotive industry for “floor mounted” installations in bodyshops. This system guarantees utmost protection of cables on shopfloors of manufacturing plants against any kind of mechanical impact.



FLOOR-MOUNT CABLE TRAY SYSTEM

Available Side Rail Heights

Height 60 mm	Nominal 2 3/8 inches	Height 100 mm	Nominal 4 inches	Height 110 mm	Nominal 4 3/8 inches
--------------------	----------------------------	---------------------	------------------------	---------------------	----------------------------

SYSTEM			60	100	110
	Heavy Duty Cable Tray	RSUS 60...	↓ 60		Page 240
	Heavy Duty Cable Tray	RSSKP...	↑ 100		Page 241
ACCESSORIES	Heavy Duty Cable Tray	RSSUP...	↑ 100		Page 241
	Universal Splice Plate	RSUV 60-1.5	↓ 60		Page 240
	Universal Splice Plate	RSUVKS...	↑ 100		Page 241
	Heavy Duty Divider	RW 60-2.0 S	↓ 60		Page 240
	Heavy Duty Divider	RW...	↑ 100		Page 241
	Pair of Protective Caps	SKKSA 60	↓ 60		Page 240
	Pair of Protective Caps	SKKSA 100/ SKKSA 110	↑ 100		Page 242
	Flexible Divider	RTSQF...	↑ 100		Page 242
	Elbow 45°	RBAS...	↑ 100		Page 242
	Elbow 90°	RESS...	↑ 100		Page 242
	Extension Tee	RTAS...	↑ 100		Page 243
	Horizontal Tee	RTSS...	↑ 100		Page 243
	Vertical Outside Elbow 90° (2x45°)	RFDU...	↑ 100		Page 243
	Vertical Inside Elbow 90° (2x45°)	RSDU...	↑ 100		Page 243
	Reducer/Blind End	RA...	↑ 100		Page 244
	Adjustable Horizontal Splice/Reducer/Blind End	RAW...	↑ 100		Page 244
	End Plate with Cover Lock	RADS...	↑ 100		Page 244
	Mounting Bracket for Heavy Duty Cable Tray	STWBKS 100/110-1.5 S			Page 248
	Heavy Duty Antiskid Cover (DIN 51130 class R10)	RDRS...			Page 249
	Heavy Duty Antiskid Cover for 45° Horizontal Elbow	RBADVRS...			Page 249
	Heavy Duty Antiskid Cover for 90° Horizontal Elbow	RESVRS...			Page 249
	Heavy Duty Antiskid Cover for Horizontal Extension Tee	RTADVRS...			Page 249
	Heavy Duty Antiskid Cover for Horizontal Tee	RTSDVRS...			Page 250
	Heavy Duty Turnbolt Lock / Turnbolt Lock	RDRS 9X2/RDRS 2			Page 250/251
	Heavy Duty Cover Clamp	RDHFS 9 VZL			Page 251
	Dust Protection Strip	DSL...			Page 252
	Cover Removing Tool	DHBKS 170 S			Page 252
	Bearing for Framing Channel	TR 86 S			Page 252
	Tee-Connector	TV 40			Page 253
	2986 Framing Channel	2986/...			Page 253
	Floor Mounting Bracket (height: 50 mm)	RZP 50/...			Page 253
	Floor Mounting Bracket (height: 100 mm)	RZP 100/...			Page 254
	Floor Clamp	RZPBL 25.90			Page 254
	Floor Mounting Bracket	RSSZS...			Page 254
	Skirting Panel	VBASB...			Page 254
	Retaining Clip for Skirting Panel	HKVB 85-110 E2			Page 254
	Floor Stand (height: 85 mm)	RDB 85...			Page 255
	Skirting Panel	VBASB 92.8-1.5/3000 S			Page 255
	Floor Stand	RSSTAU 108...			Page 255
	Skirting Panel	VBASB 106.7-2.0/3000 S			Page 256
	Large Diameter Washer	UGM...			Page 256
	Carriage Bolt with Nut	FLM...			Page 256
	Pan-Head Torx Bolt	LFM 6X16-TX V			Page 256
	Self-Tapping Screw with Pan-Head	B 4.2X13-TX V			Page 256
	Expansion Anchor	DAZ...			Page 256
	Concrete Screw Anchor	NSA 7.5X...			Page 257



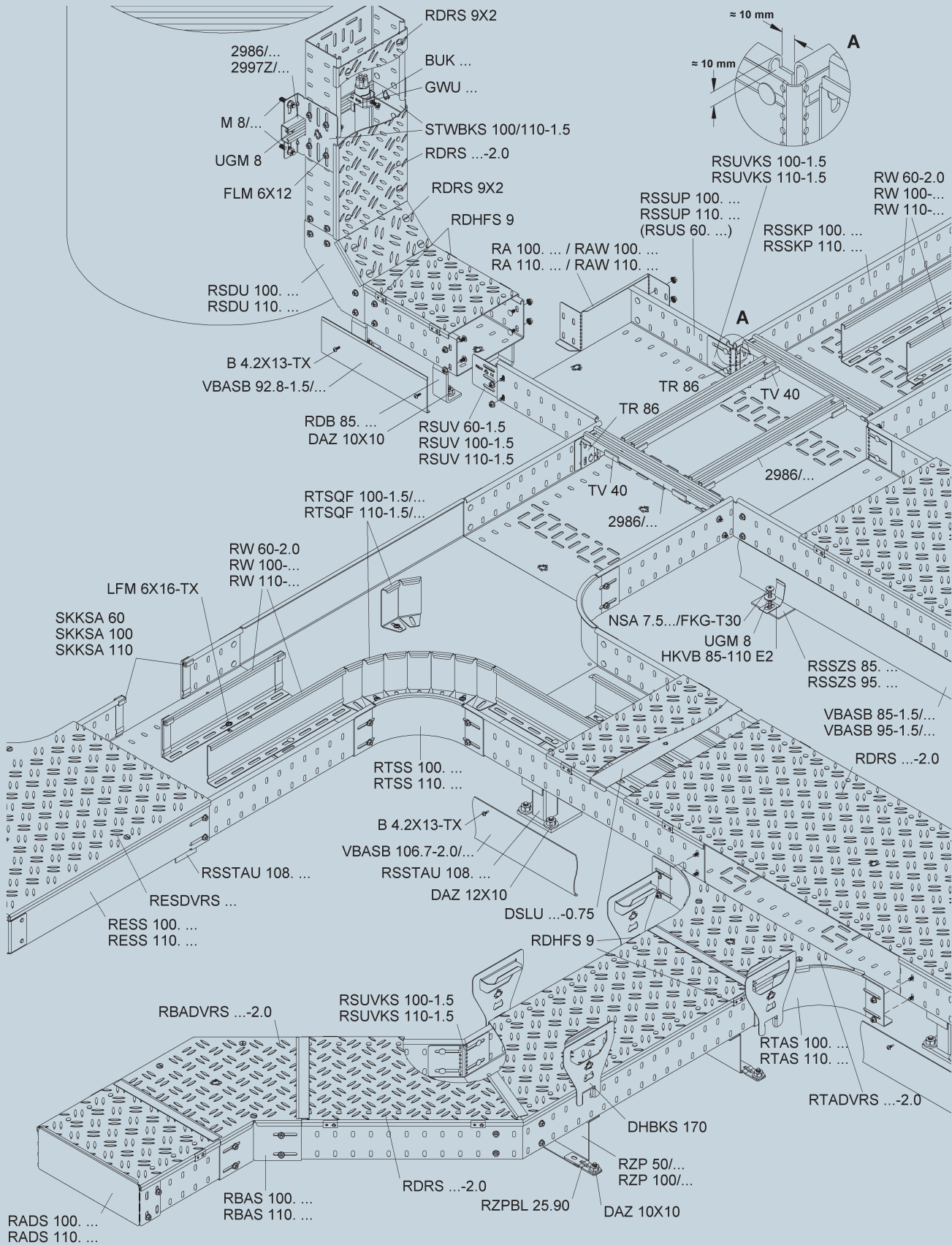

FLOOR-MOUNT CABLE TRAY SYSTEM

Heavy Duty Cable Tray

splice plates not included

	Model no.	Height H		Width B		Thick-ness t	Weight per 100 m	Pack/Box Qty
		mm	Inch	mm	Inch			
S	RSUS 60.100 OV	60	2,4	100	3,9	2	373,63	2 x 3 m
S	RSUS 60.200 OV	60	2,4	200	7,9	2	530,63	2 x 3 m
S	RSUS 60.300 OV	60	2,4	300	11,8	2	687,55	2 x 3 m

with splice plate holes on both ends, as well as stabilizing rolled longitudinal edges

Standard fittings can be used in combination with covers for the walkable system.

Please order 2 universal splice plates RSUV 60-1.5 for each joint extra.

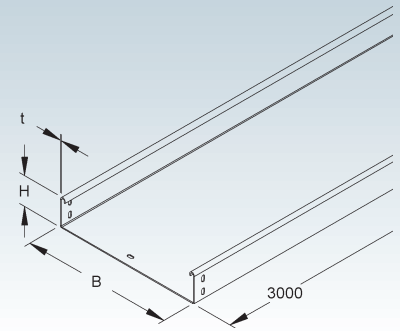

Universal Splice Plate

	Model no.	Height H		Width B		Thick-ness t	Acc. incl.	Weight per 100 pcs	Pack/Box Qty
		mm	Inch	mm	Inch				
S	RSUV 60-1.5	51	2	150	5,9	1,5	4 FLM 6X12	11,48	50

for straight and angled joints

Height 60 mm
Nominal 2 3/8 inches

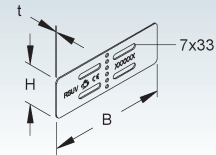

Heavy Duty Divider

with longitudinal hole pattern

	Model no.	Height H		Thick-ness t	Acc. incl.	Weight per 100 m	Pack/Box Qty
		mm	Inch				
S	RW 60-2.0 S	58	2,3	2	4 FLM 6X12	146,23	3 m

for continuously variable sizing of cable compartments

Minimum number of dividers required to support the floor-mount covers:

for cover width 100 and 200 mm = none

for cover width 300 mm and 400 mm = 1 piece with a maximum compartment width of 200 mm

for cover width 500 mm and 600 mm = 2 pieces with a maximum compartment width of 200 mm

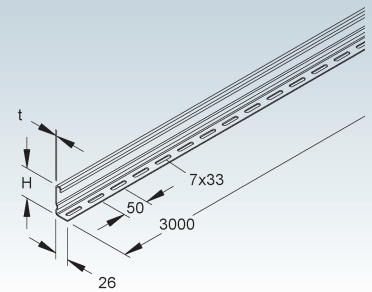

Pair of Protective Caps

	Model no.	Color	Height H		Weight per 100 pair	Pack/Box Qty
			mm	Inch		
K03	SKKSA 60	black	58	2,3	0,94	25 pair

for covering the cable trays/barrier strip ends with 60 mm edge height and 1.5 to 2 mm material thickness

to protect the installed cables from damage

Suitable for: cable trays RSUS 60..., RS 60... and RSU 60... as well as barrier strip RW 60-2.0...

To ensure that the protective caps can be fitted without any problems, a distance of at least 25 mm from the cable tray/barrier strip ends must be kept free of hardware obstructions.

Height 60 mm
Nominal 2 3/8 inches

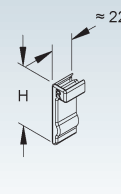

Heavy Duty Cable Tray

ventilated bottom, solid sides, embossed knockouts

	Model no.	Height H		Width B		Thick-ness t mm	Weight per 100 m kg	Pack/Box Qty
		mm	Inch	mm	Inch			
S	RSSKP 100.100 S OV	100	3,9	100	3,9	2	493,89	2 x 3 m
S	RSSKP 100.200 S OV	100	3,9	200	7,9	2	641,66	2 x 3 m
S	RSSKP 100.300 S OV	100	3,9	300	11,8	2	789,43	2 x 3 m
S	RSSKP 100.400 S OV	100	3,9	400	15,7	2	937,20	2 x 3 m
S	RSSKP 100.500 S OV	100	3,9	500	19,7	2	1.084,97	2 x 3 m
S	RSSKP 100.600 S OV	100	3,9	600	23,6	2	1.232,74	2 x 3 m

with perforated bottom for floor stand and divider mounting
with 4 prepunched holes for splice plates on each end and embossed knockouts for additional holes that may be required

RSUVKS 100-1.5 S splice plates are not included, 2 pieces are required per section of tray

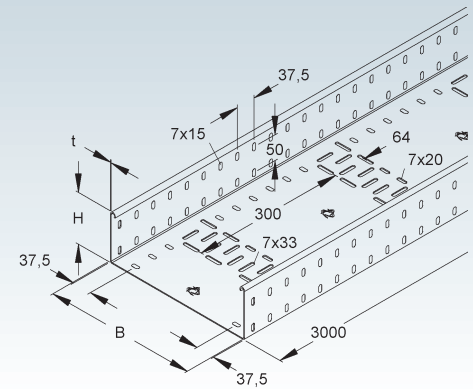
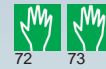

Heavy Duty Cable Tray

with solid bottom, solid sides, embossed knockouts

	Model no.	Height H		Width B		Thick-ness t mm	Weight per 100 m kg	Pack/Box Qty
		mm	Inch	mm	Inch			
S	RSSUP 100.100 S OV	100	3,9	100	3,9	2	497,65	2 x 3 m
S	RSSUP 100.200 S OV	100	3,9	200	7,9	2	654,65	2 x 3 m
S	RSSUP 100.300 S OV	100	3,9	300	11,8	2	811,65	2 x 3 m
S	RSSUP 100.400 S OV	100	3,9	400	15,7	2	968,17	2 x 3 m
S	RSSUP 100.500 S OV	100	3,9	500	19,7	2	1.125,65	2 x 3 m
S	RSSUP 100.600 S OV	100	3,9	600	23,6	2	1.282,17	2 x 3 m

with 4 prepunched holes for splice plates on each end and embossed knockouts for additional holes that may be required

RSUVKS 100-1.5 S splice plates are not included, 2 pieces are required per section of tray

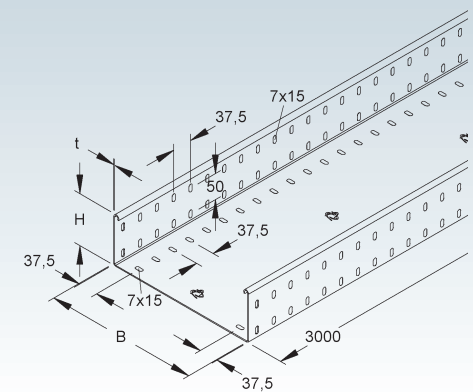
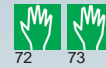

Universal Splice Plate

with rounded ridge for protecting cables at angled joints

	Model no.	Height H	Width B	Thick-ness t mm	Acc. incl.	Weight per 100 pcs kg	Pack/Box Qty	
		mm	Inch	mm				
S	RSUVKS 100-1.5 S	79	3,1	148	5,8	1,5	4 FLM 6X12 15,18	50

for straight and angled horizontal joints

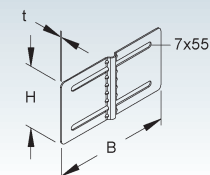

Heavy Duty Divider

with longitudinal hole pattern

	Model no.	Height H	Thick-ness t mm	Acc. incl.	Weight per 100 m kg	Pack/Box Qty	
		mm	Inch				
S	RW 100-1.5 S	98	3,9	1,5	4 FLM 6X12	159,60	3 m
S	RW 100-2.0 S	98	3,9	2,0	4 FLM 6X12	209,03	3 m

for continuously variable sizing of cable compartments

Minimum number of dividers required to support the floor-mount covers:

for cover width 100 and 200 mm = none

for cover width 300 mm and 400 mm = 1 piece with a maximum compartment width of 200 mm

for cover width 500 mm and 600 mm = 2 pieces with a maximum compartment width of 200 mm

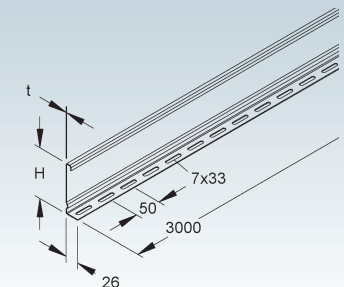

FLOOR-MOUNT CABLE TRAY SYSTEM

Pair of Protective Caps

Model no.	Color	Height H mm Inch	Weight per 100 pair kg	Pack/Box Qty
K03 SKKSA 100	black	98 3,9	1,47	25 pair

for covering the cable trays/barrier strip ends with 100 mm edge height and 1.5 to 2 mm material thickness to protect the installed cables from damage

Suitable for: cable trays RSSKP 100... and RSSUP 100... as well as barrier strips RW 100-... and RTSQF 100-...

To ensure that the protective caps can be fitted without any problems, a distance of at least 25 mm from the cable tray/barrier strip ends must be kept free of hardware obstructions.

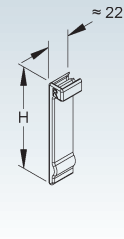

Flexible Divider

with elongated mounting holes

Model no.	Height H mm Inch	Thickness t mm	Acc. incl.	Weight per 100 m kg	Pack/Box Qty
S RTSQF 100-1.5/1000 S	98 3,9	1,5	3 FLM 6X12	156,98	1 m

segmented for easy horizontal bending

Minimum number of dividers required to support the floor-mount covers:

for cover width 100 and 200 mm = none

for cover width 300 mm and 400 mm = 1 piece with a maximum compartment width of 200 mm

for cover width 500 mm and 600 mm = 2 pieces with a maximum compartment width of 200 mm

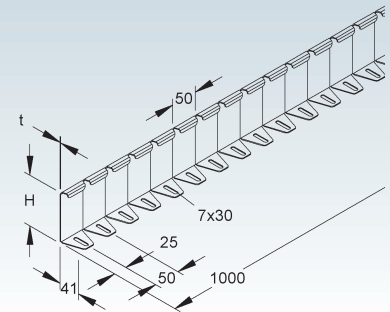
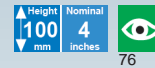

Elbow 45°

solid sides with integrated splice plate

Model no.	Height H mm Inch	Inside dimension B mm Inch	Thickness t mm	Acc. incl.	Weight per 100 pcs kg	Pack/Box Qty
S RBAS 100.100 S	100 3,9	100 3,9	2	8 FLM 6X12	114,28	1
S RBAS 100.200 S	100 3,9	200 7,9	2	8 FLM 6X12	160,42	1
S RBAS 100.300 S	100 3,9	300 11,8	2	8 FLM 6X12	219,56	1
S RBAS 100.400 S	100 3,9	400 15,7	2	8 FLM 6X12	291,71	1
S RBAS 100.500 S	100 3,9	500 19,7	2	8 FLM 6X12	376,87	1
S RBAS 100.600 S	100 3,9	600 23,6	2	8 FLM 6X12	475,03	1

for horizontal 45° deviations

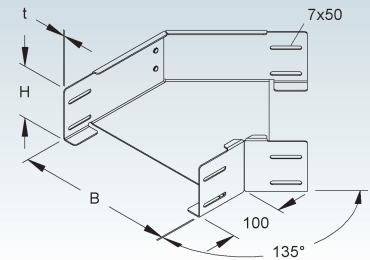

Elbow 90°

solid sides with integrated splice plate

Model no.	Height H mm Inch	Inside dimension B mm Inch	Thickness t mm	Acc. incl.	Weight per 100 pcs kg	Pack/Box Qty
S RESS 100.100 S	100 3,9	100 3,9	2	8 FLM 6X12	240,70	1
S RESS 100.200 S	100 3,9	200 7,9	2	8 FLM 6X12	362,90	1
S RESS 100.300 S	100 3,9	300 11,8	2	8 FLM 6X12	516,51	1
S RESS 100.400 S	100 3,9	400 15,7	2	8 FLM 6X12	701,51	1
S RESS 100.500 S	100 3,9	500 19,7	2	8 FLM 6X12	917,92	1
S RESS 100.600 S	100 3,9	600 23,6	2	8 FLM 6X12	1.165,72	1

for horizontal 90° deviations

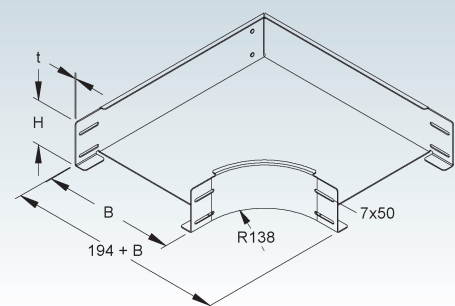

Extension Tee

solid sides with integrated splice plate

	Model no.	Height H		Inside dimension B		Thick-ness t	Acc. incl.	Weight per 100 pcs kg	Pack/Box Qty
		mm	Inch	mm	Inch				
S	RTAS 100.100 S	100	3,9	100	3,9	2	8 FLM 6X12	172,55	1
S	RTAS 100.200 S	100	3,9	200	7,9	2	8 FLM 6X12	193,27	1
S	RTAS 100.300 S	100	3,9	300	11,8	2	8 FLM 6X12	213,99	1
S	RTAS 100.400 S	100	3,9	400	15,7	2	8 FLM 6X12	234,72	1
S	RTAS 100.500 S	100	3,9	500	19,7	2	8 FLM 6X12	255,44	1
S	RTAS 100.600 S	100	3,9	600	23,6	2	8 FLM 6X12	276,17	1

for horizontal tee connections of cable trays

Height 100 mm
Nominal 4 inches

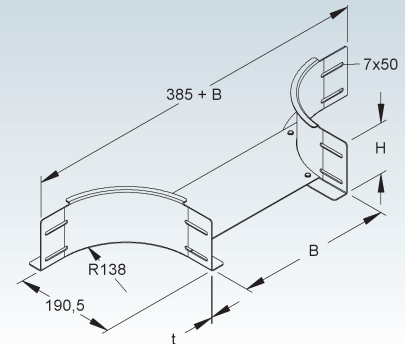

Horizontal Tee

solid sides with integrated splice plate

	Model no.	Height H		Inside dimension B		Thick-ness t	Acc. incl.	Weight per 100 pcs kg	Pack/Box Qty
		mm	Inch	mm	Inch				
S	RTSS 100.100 S	100	3,9	100	3,9	2	12 FLM 6X12	319,79	1
S	RTSS 100.200 S	100	3,9	200	7,9	2	12 FLM 6X12	441,34	1
S	RTSS 100.300 S	100	3,9	300	11,8	2	12 FLM 6X12	598,87	1
S	RTSS 100.400 S	100	3,9	400	15,7	2	12 FLM 6X12	787,81	1
S	RTSS 100.500 S	100	3,9	500	19,7	2	12 FLM 6X12	1.008,15	1
S	RTSS 100.600 S	100	3,9	600	23,6	2	12 FLM 6X12	1.259,89	1

for horizontal tee connections of cable trays with identical width

Height 100 mm
Nominal 4 inches

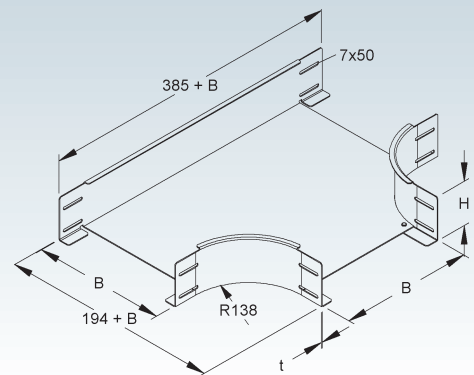

Vertical Outside Elbow 90° (2x45°)

solid sides with mounting holes for splice plates

	Model no.	Height H		Width B		Thick-ness t	Weight per 100 pc kg	Pack/Box Qty
		mm	Inch	mm	Inch			
S	RFDU 100.100-1.5 S OV	97,5	3,8	100	3,9	1,5	76,46	1
S	RFDU 100.200-1.5 S OV	97,5	3,8	200	7,9	1,5	90,99	1
S	RFDU 100.300-1.5 S OV	97,5	3,8	300	11,8	1,5	105,52	1
S	RFDU 100.400-1.5 S OV	97,5	3,8	400	15,7	1,5	120,05	1
S	RFDU 100.500-1.5 S OV	97,5	3,8	500	19,7	1,5	134,59	1
S	RFDU 100.600-1.5 S OV	97,5	3,8	600	23,6	1,5	149,12	1

Please order two RSUVKS 100 splice plates for every fitting.

Height 100 mm
Nominal 4 inches

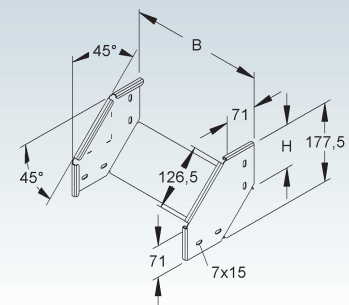

Vertical Inside Elbow 90° (2x45°)

solid sides with mounting holes for splice plates

	Model no.	Height H		Width B		Thick-ness t	Weight per 100 pc kg	Pack/Box Qty
		mm	Inch	mm	Inch			
S	RSDU 100.100-1.5 S OV	92,5	3,6	100	3,9	1,5	89,45	1
S	RSDU 100.200-1.5 S OV	92,5	3,6	200	7,9	1,5	124,08	1
S	RSDU 100.300-1.5 S OV	92,5	3,6	300	11,8	1,5	158,71	1
S	RSDU 100.400-1.5 S OV	92,5	3,6	400	15,7	1,5	193,34	1
S	RSDU 100.500-1.5 S OV	92,5	3,6	500	19,7	1,5	227,97	1
S	RSDU 100.600-1.5 S OV	92,5	3,6	600	23,6	1,5	262,60	1

Please order two RSUVKS 100 splice plates for every fitting.

Height 100 mm
Nominal 4 inches

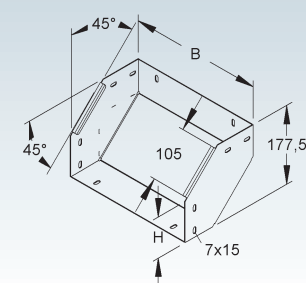

FLOOR-MOUNT CABLE TRAY SYSTEM

Reducer/Blind End

	Model no.	Height H		Width B		Width B1		Acc. incl.	Weight per 100 pcs kg	Pack/Box Qty
		mm	Inch	mm	Inch	mm	Inch			
S	RA 100.200 S	100	3,9	200	7,9	322	12,7	4 FLM 6X12	32,20	20
S	RA 100.400 S	100	3,9	400	15,7	522	20,6	4 FLM 6X12	51,62	20
S	RA 100.500 S	100	3,9	500	19,7	622	24,5	4 FLM 6X12	61,33	20
S	RA 100.600 S	100	3,9	600	23,6	722	28,4	4 FLM 6X12	71,04	20

can be used as a blind end or as a reducer for cable trays

Height
100
mm

Nominal
4
inches

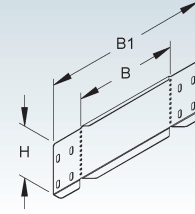

Adjustable Horizontal Splice/Reducer/Blind End

	Model no.	Height H		Width B		Width B1		Acc. incl.	Weight per 100 pcs kg	Pack/Box Qty
		mm	Inch	mm	Inch	mm	Inch			
S	RAW 100.100 S	100	3,9	100	3,9	222	8,7	4 FLM 6X12	22,14	20
S	RAW 100.300 S	100	3,9	300	11,8	422	16,6	4 FLM 6X12	41,56	20

can be used as a blind end or as a reducer for cable trays

Height
100
mm

Nominal
4
inches

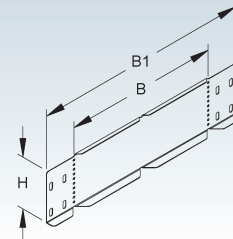

Blind End with Cover Lock

	Model no.	Height H		Width B		Width B1		Acc. incl.	Weight per 100 pcs kg	Pack/Box Qty
		mm	Inch	mm	Inch	mm	Inch			
S	RADS 100.100 S	107,5	4,2	100	3,9	222	8,7	4 FLM 6X12	20,72	20
S	RADS 100.200 S	107,5	4,2	200	7,9	322	12,7	4 FLM 6X12	29,66	20
S	RADS 100.300 S	107,5	4,2	300	11,8	422	16,6	4 FLM 6X12	38,60	20
S	RADS 100.400 S	107,5	4,2	400	15,7	522	20,6	4 FLM 6X12	47,53	20
S	RADS 100.500 S	107,5	4,2	500	19,7	622	24,5	4 FLM 6X12	56,47	20
S	RADS 100.600 S	107,5	4,2	600	23,6	722	28,4	4 FLM 6X12	65,41	20

for terminating floor-mount cable tray, with elevated flange to prevent covers from sliding lengthwise

Height
100
mm

Nominal
4
inches

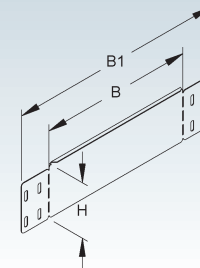

Heavy Duty Cable Tray

ventilated bottom, solid sides, embossed knockouts

	Model no.	Height H		Width B		Thick-ness t	Weight per 100 m	Pack/Box Qty
		mm	Inch	mm	Inch			
S	RSSKP 110.100 S OV	110	4,3	100	3,9	2	525,39	2 x 3 m
S	RSSKP 110.200 S OV	110	4,3	200	7,9	2	673,07	2 x 3 m
S	RSSKP 110.300 S OV	110	4,3	300	11,8	2	820,83	2 x 3 m
S	RSSKP 110.400 S OV	110	4,3	400	15,7	2	968,60	2 x 3 m
S	RSSKP 110.500 S OV	110	4,3	500	19,7	2	1.116,37	2 x 3 m
S	RSSKP 110.600 S OV	110	4,3	600	23,6	2	1.264,14	2 x 3 m

with perforated bottom for floor stand and divider mounting
with 4 prepunched holes for splice plates on each end and embossed knockouts for additional holes that may be required

RSUVKS 110-1.5 S splice plates are not included, 2 pieces are required per section of tray

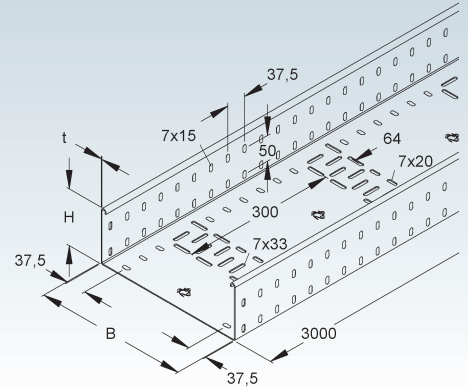
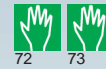

Heavy Duty Cable Tray

with solid bottom, solid sides, embossed knockouts

	Model no.	Height H		Width B		Thick-ness t	Weight per 100 m	Pack/Box Qty
		mm	Inch	mm	Inch			
S	RSSUP 110.100 S OV	110	4,3	100	3,9	2	529,05	2 x 3 m
S	RSSUP 110.200 S OV	110	4,3	200	7,9	2	686,05	2 x 3 m
S	RSSUP 110.300 S OV	110	4,3	300	11,8	2	843,05	2 x 3 m
S	RSSUP 110.400 S OV	110	4,3	400	15,7	2	1.000,05	2 x 3 m
S	RSSUP 110.500 S OV	110	4,3	500	19,7	2	1.157,05	2 x 3 m
S	RSSUP 110.600 S OV	110	4,3	600	23,6	2	1.314,05	2 x 3 m

with 4 prepunched holes for splice plates on each end and embossed knockouts for additional holes that may be required

RSUVKS 110-1.5 S splice plates are not included, 2 pieces are required per section of tray

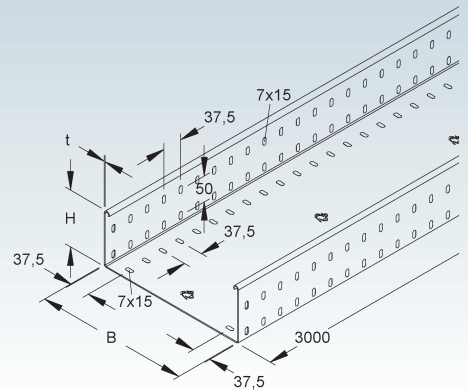
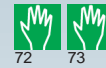

Universal Splice Plate

with rounded ridge for protecting cables at angled joints

	Model no.	Height H	Width B	Thick-ness t	Acc. incl.	Weight per 100 pcs	Pack/Box Qty
		mm	mm	mm		kg	
S	RSUVKS 110-1.5 S	94	148	1,5	4 FLM 6X12	17,81	50

for straight and angled horizontal joints

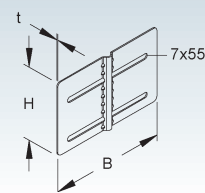

Heavy Duty Divider

with longitudinal hole pattern

	Model no.	Height H	Thick-ness t	Acc. incl.	Weight per 100 m	Pack/Box Qty
		mm	mm		kg	
S	RW 110-1.5 S	108	1,5	4 FLM 6X12	171,37	3 m
S	RW 110-2.0 S	108	2,0	4 FLM 6X12	224,73	3 m

for continuously variable sizing of cable compartments

Minimum number of dividers required to support the floor-mount covers:

for cover width 100 and 200 mm = none

for cover width 300 mm and 400 mm = 1 piece with a maximum compartment width of 200 mm

for cover width 500 mm and 600 mm = 2 pieces with a maximum compartment width of 200 mm

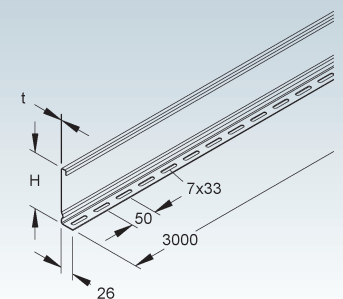

FLOOR-MOUNT CABLE TRAY SYSTEM

Pair of Protective Caps

Model no.	Color	Height H mm Inch	Weight per 100 pair kg	Pack/Box Qty
K03 SKKSA 110	black	108 4,3	1,61	25 pair

for covering the cable trays/barrier strip ends with 110 mm edge height and 1.5 to 2 mm material thickness to protect the installed cables from damage

Suitable for: Cable trays RSSKP 110..., RSSUP 110..., RSU 110... and RSV 110... as well as barrier strips RW 110... and RTSQF 110-...

To ensure that the protective caps can be fitted without any problems, a distance of at least 25 mm from the cable tray/barrier strip ends must be kept free of hardware obstructions.

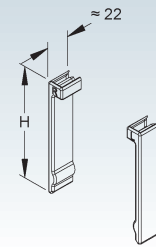

Flexible Divider

with elongated mounting holes

Model no.	Height H mm Inch	Thickness t mm	Acc. incl.	Weight per 100 m kg	Pack/Box Qty
S RTSQF 110-1.5/1000 S	108 4,3	1,5	3 FLM 6X12	168,72	1 m

segmented for easy horizontal bending

Minimum number of dividers required to support the floor-mount covers:

for cover width 100 and 200 mm = none

for cover width 300 mm and 400 mm = 1 piece with a maximum compartment width of 200 mm

for cover width 500 mm and 600 mm = 2 pieces with a maximum compartment width of 200 mm

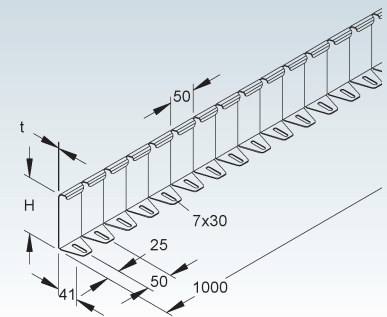
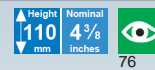

Elbow 45°

solid sides with integrated splice plate

Model no.	Height H mm Inch	Inside dimension B mm Inch	Thickness t mm	Acc. incl.	Weight per 100 pcs kg	Pack/Box Qty
S RBAS 110.100	110 4,3	100 3,9	2	8 FLM 6X12	121,79	1
S RBAS 110.200	110 4,3	200 7,9	2	8 FLM 6X12	169,23	1
S RBAS 110.300	110 4,3	300 11,8	2	8 FLM 6X12	229,67	1
S RBAS 110.400	110 4,3	400 15,7	2	8 FLM 6X12	303,39	1
S RBAS 110.500	110 4,3	500 19,7	2	8 FLM 6X12	389,58	1
S RBAS 110.600	110 4,3	600 23,6	2	8 FLM 6X12	489,04	1

for horizontal 45° deviations

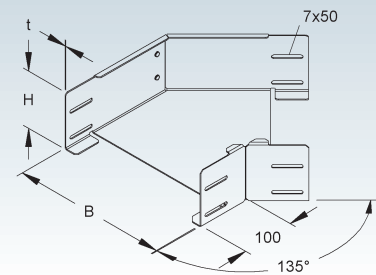

Elbow 90°

solid sides with integrated splice plate

Model no.	Height H mm Inch	Inside dimension B mm Inch	Thickness t mm	Acc. incl.	Weight per 100 pcs kg	Pack/Box Qty
S RESS 110.100	110 4,3	100 3,9	2	8 FLM 6X12	255,75	1
S RESS 110.200	110 4,3	200 7,9	2	8 FLM 6X12	381,09	1
S RESS 110.300	110 4,3	300 11,8	2	8 FLM 6X12	537,84	1
S RESS 110.400	110 4,3	400 15,7	2	8 FLM 6X12	725,98	1
S RESS 110.500	110 4,3	500 19,7	2	8 FLM 6X12	945,53	1
S RESS 110.600	110 4,3	600 23,6	2	8 FLM 6X12	1.196,47	1

for horizontal 90° deviations

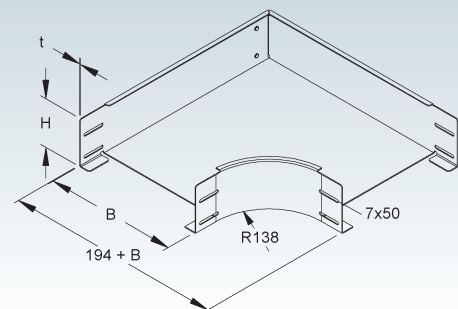

Extension Tee

solid sides with integrated splice plate

	Model no.	Height H		Inside dimension B		Thick-ness t	Acc. incl.	Weight per 100 pcs kg	Pack/Box Qty
		mm	Inch	mm	Inch				
S	RTAS 110.100	110	4,3	100	3,9	2	8 FLM 6X12	182,77	1
S	RTAS 110.200	110	4,3	200	7,9	2	8 FLM 6X12	203,50	1
S	RTAS 110.300	110	4,3	300	11,8	2	8 FLM 6X12	224,22	1
S	RTAS 110.400	110	4,3	400	15,7	2	8 FLM 6X12	244,95	1
S	RTAS 110.500	110	4,3	500	19,7	2	8 FLM 6X12	265,67	1
S	RTAS 110.600	110	4,3	600	23,6	2	8 FLM 6X12	286,39	1

for horizontal tee connections of cable trays

Height 110 mm
Nominal 4 3/8 inches

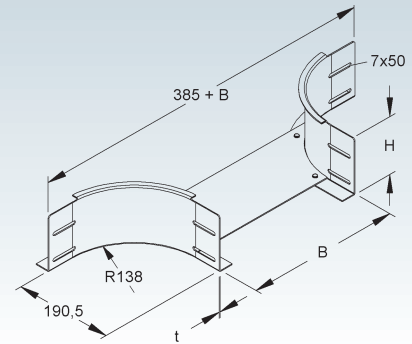

Horizontal Tee

solid sides with integrated splice plate

	Model no.	Height H		Inside dimension B		Thick-ness t	Acc. incl.	Weight per 100 pcs kg	Pack/Box Qty
		mm	Inch	mm	Inch				
S	RTSS 110.100	110	4,3	100	3,9	2	12 FLM 6X12	333,04	1
S	RTSS 110.200	110	4,3	200	7,9	2	12 FLM 6X12	460,75	1
S	RTSS 110.300	110	4,3	300	11,8	2	12 FLM 6X12	619,86	1
S	RTSS 110.400	110	4,3	400	15,7	2	12 FLM 6X12	810,36	1
S	RTSS 110.500	110	4,3	500	19,7	2	12 FLM 6X12	1.032,27	1
S	RTSS 110.600	110	4,3	600	23,6	2	12 FLM 6X12	1.285,58	1

for horizontal tee connections of cable trays with identical width

Height 110 mm
Nominal 4 3/8 inches

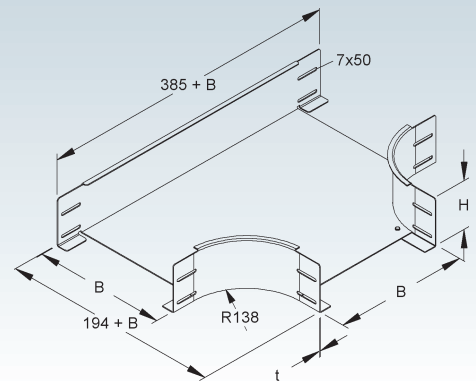

Vertical Outside Elbow 90° (2x45°)

solid sides with mounting holes for splice plates

	Model no.	Height H		Width B		Thick-ness t	Weight per 100 pc kg	Pack/Box Qty
		mm	Inch	mm	Inch			
S	RFDU 110.100-1.5 S OV	107,5	4,2	100	3,9	1,5	84,23	1
S	RFDU 110.200-1.5 S OV	107,5	4,2	200	7,9	1,5	98,76	1
S	RFDU 110.300-1.5 S OV	107,5	4,2	300	11,8	1,5	113,30	1
S	RFDU 110.400-1.5 S OV	107,5	4,2	400	15,7	1,5	127,83	1
S	RFDU 110.500-1.5 S OV	107,5	4,2	500	19,7	1,5	142,36	1
S	RFDU 110.600-1.5 S OV	107,5	4,2	600	23,6	1,5	156,89	1

Please order two RSUVKS 110 splice plates for every fitting.

Height 110 mm
Nominal 4 3/8 inches

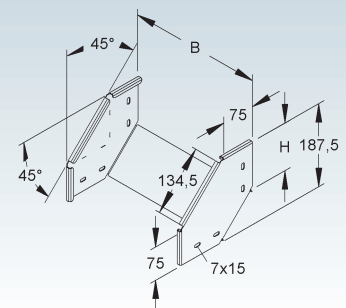

Vertical Inside Elbow 90° (2x45°)

solid sides with mounting holes for splice plates

	Model no.	Height H		Width B		Thick-ness t	Weight per 100 pc kg	Pack/Box Qty
		mm	Inch	mm	Inch			
S	RSDU 110.100-1.5 S OV	106,5	4,2	100	3,9	1,5	97,93	1
S	RSDU 110.200-1.5 S OV	106,5	4,2	200	7,9	1,5	134,22	1
S	RSDU 110.300-1.5 S OV	106,5	4,2	300	11,8	1,5	170,52	1
S	RSDU 110.400-1.5 S OV	106,5	4,2	400	15,7	1,5	206,82	1
S	RSDU 110.500-1.5 S OV	106,5	4,2	500	19,7	1,5	243,11	1
S	RSDU 110.600-1.5 S OV	106,5	4,2	600	23,6	1,5	279,41	1

Please order two RSUVKS 110 splice plates for every fitting.

Height 110 mm
Nominal 4 3/8 inches

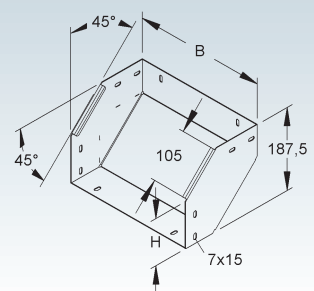

FLOOR-MOUNT CABLE TRAY SYSTEM

Reducer/Blind End

	Model no.	Height H	Width B	Width B1	Acc. incl.	Weight per 100 pcs kg	Pack/ Box Qty
		mm Inch	mm Inch	mm Inch			
S	RA 110.200	110 4,3	200 7,9	322 12,7	4 FLM 6X12	34,39	20
S	RA 110.400	110 4,3	400 15,7	522 20,6	4 FLM 6X12	55,38	20
S	RA 110.600	110 4,3	600 23,6	722 28,4	4 FLM 6X12	76,37	20

can be used as blind end or as reducer for cable trays

▲ Height
110
mm
▼

Nominal
4 3/8
inches

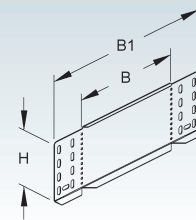

Adjustable Horizontal Splice/Reducer/Blind End

	Model no.	Height H	Width B	Width B1	Acc. incl.	Weight per 100 pcs kg	Pack/ Box Qty
		mm Inch	mm Inch	mm Inch			
S	RAW 110.100	110 4,3	100 3,9	222 8,7	4 FLM 6X12	23,60	20
S	RAW 110.300	110 4,3	300 11,8	422 16,6	4 FLM 6X12	44,59	20

can be used as blind end or as reducer for cable trays

▲ Height
110
mm
▼

Nominal
4 3/8
inches

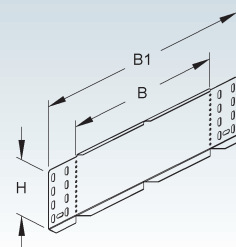

Blind End with Cover Lock

	Model no.	Height H	Width B	Width B1	Acc. incl.	Weight per 100 pcs kg	Pack/ Box Qty
		mm Inch	mm Inch	mm Inch			
S	RADS 110.100 S	117,5 4,6	100 3,9	222 8,7	4 FLM 6X12	22,43	20
S	RADS 110.200 S	117,5 4,6	200 7,9	322 12,7	4 FLM 6X12	31,63	20
S	RADS 110.300 S	117,5 4,6	300 11,8	422 16,6	4 FLM 6X12	41,88	20
S	RADS 110.400 S	117,5 4,6	400 15,7	522 20,6	4 FLM 6X12	51,60	20
S	RADS 110.500 S	117,5 4,6	500 19,7	622 24,5	4 FLM 6X12	61,32	20
S	RADS 110.600 S	117,5 4,6	600 23,6	722 28,4	4 FLM 6X12	71,05	20

for terminating floor-mount cable tray, with elevated flange to prevent covers from sliding lengthwise

▲ Height
110
mm
▼

Nominal
4 3/8
inches

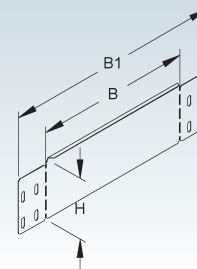

Mounting Bracket for Heavy Duty Cable Tray

	Model no.	Height H	Width B	Thick- ness t	Acc. incl.	Weight per 100 pcs kg	Pack/ Box Qty
		mm Inch	mm Inch	mm			
S	STWBKS 100/110-1.5 S	119 4,7	150 5,9	1,5	5 FLM 6X12	26,99	10

designed as a splice plate and mounting bracket for vertical installations of heavy duty cable tray
The centered notch allows the installation of 2986.../2997Z... cut-to-length channel segments in between two pieces of tray

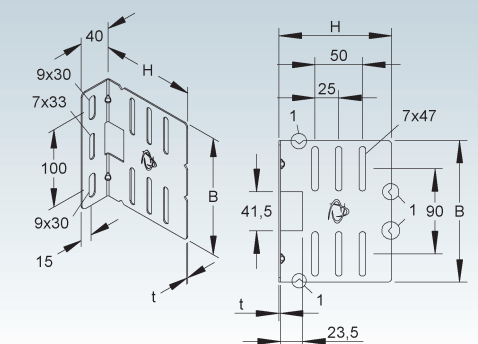

Heavy Duty Antiskid Cover (DIN 51130 class R10)

with embossed notches for turnbolt installation

Model no.		Inside dimension B		Thick-ness t	Weight per 100 m	Pack/Box Qty
		mm	Inch			
S	RDRS 100-2.0 S	105	4,1	3,25	201,91	3 m
S	RDRS 200-2.0 S	205	8,1	3,25	359,19	3 m
S	RDRS 300-2.0 S	305	12	3,25	516,48	3 m
S	RDRS 400-2.0 S	405	15,9	3,25	673,78	3 m
S	RDRS 500-2.0 S	505	19,9	3,25	831,07	3 m
S	RDRS 600-2.0 S	605	23,8	3,25	988,36	3 m

The nominal thickness "t" includes the diamond pattern.

RDRS 9X2 turn-bolt locks or RDHFS 9 VZL cover clamps are required to fix the cover on the tray. Please order separately.

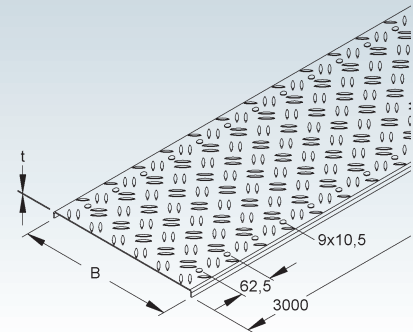

Heavy Duty Antiskid Cover for 45° Horizontal Elbow

with preinstalled turnbolt locks

Model no.		Inside dimension B		Thick-ness t	Weight per 100 pcs	Pack/Box Qty
		mm	Inch			
S	RBADVRS 100-2.0 S	105	4,1	3,25	49,81	1
S	RBADVRS 200-2.0 S	205	8,1	3,25	102,76	1
S	RBADVRS 300-2.0 S	305	12	3,25	168,79	1
S	RBADVRS 400-2.0 S	405	15,9	3,25	247,87	1
S	RBADVRS 500-2.0 S	505	19,9	3,25	339,93	1
S	RBADVRS 600-2.0 S	605	23,8	3,25	445,04	1

The nominal thickness "t" includes the diamond pattern.

Please install the requested number of heavy duty dividers to support the floor-mount cover.

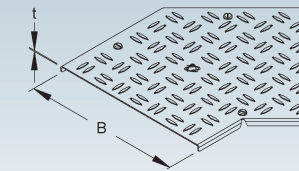

Heavy Duty Antiskid Cover for 90° Horizontal Elbow

with preinstalled turnbolt locks

Model no.		Inside dimension B		Thick-ness t	Weight per 100 pcs	Pack/Box Qty
		mm	Inch			
S	RESDVRS 100-2.0 S	105	4,1	3,25	99,34	1
S	RESDVRS 200-2.0 S	205	8,1	3,25	211,39	1
S	RESDVRS 300-2.0 S	305	12	3,25	354,91	1
S	RESDVRS 400-2.0 S	405	15,9	3,25	529,88	1
S	RESDVRS 500-2.0 S	505	19,9	3,25	736,30	1
S	RESDVRS 600-2.0 S	605	23,8	3,25	974,24	1

The nominal thickness "t" includes the diamond pattern.

Please install the requested number of heavy duty dividers to support the floor-mount cover.

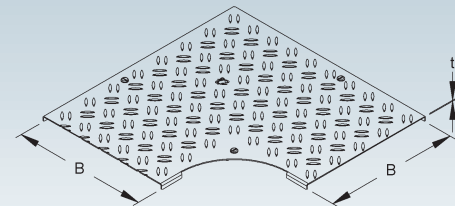

Heavy Duty Antiskid Cover for Horizontal Extension Tee

with preinstalled turnbolt locks

Model no.		Inside dimension B		Thick-ness t	Weight per 100 pcs	Pack/Box Qty
		mm	Inch			
S	RTADVRS 100-2.0 S	105	4,1	3,25	48,39	1
S	RTADVRS 200-2.0 S	205	8,1	3,25	78,74	1
S	RTADVRS 300-2.0 S	305	12	3,25	109,10	1
S	RTADVRS 400-2.0 S	405	15,9	3,25	139,45	1
S	RTADVRS 500-2.0 S	505	19,9	3,25	169,81	1
S	RTADVRS 600-2.0 S	605	23,8	3,25	200,16	1

The nominal thickness "t" includes the diamond pattern.

Please install the requested number of heavy duty dividers to support the floor-mount cover.

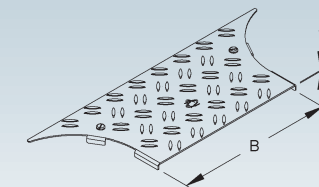

FLOOR-MOUNT CABLE TRAY SYSTEM

Heavy Duty Antiskid Cover for Horizontal Tee

with preinstalled turnbolt locks

	Model no.	Inside dimension B mm Inch	Thick-ness t mm	Weight per 100 pcs kg	Pack/Box Qty
S	RTSDVRS 100-2.0 S	105 4,1	3,25	137,24	1
S	RTSDVRS 200-2.0 S	205 8,1	3,25	277,56	1
S	RTSDVRS 300-2.0 S	305 12	3,25	449,36	1
S	RTSDVRS 400-2.0 S	405 15,9	3,25	652,59	1
S	RTSDVRS 500-2.0 S	505 19,9	3,25	887,33	1
S	RTSDVRS 600-2.0 S	605 23,8	3,25	1.153,49	1

The nominal thickness "t" includes the diamond pattern.

Please install the requested number of heavy duty dividers to support the floor-mount cover.

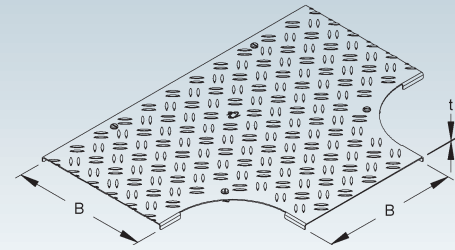

Heavy Duty Turnbolt Lock

incl. locking nut according to DIN EN ISO 10511

	Model no.	Thick-ness t mm	Acc. incl.	Weight per 100 pcs kg	Pack/Box Qty
S	RDRS 9X2	2	1 FL 6X12-S V, 1 SMS 6 V	1,84	100

Suitable for: covers RDSV..., RDRS..., RDVSRSL... and RDVSRs...

Please maintain a 50 mm minimum distance from the edge of the cover for the turn-bolt installation. Not sufficient for securing covers to tray installed vertically or sideways nor for securing covers against windloads. Please use self tapping screws, steel cable ties or coverhinges in addition.

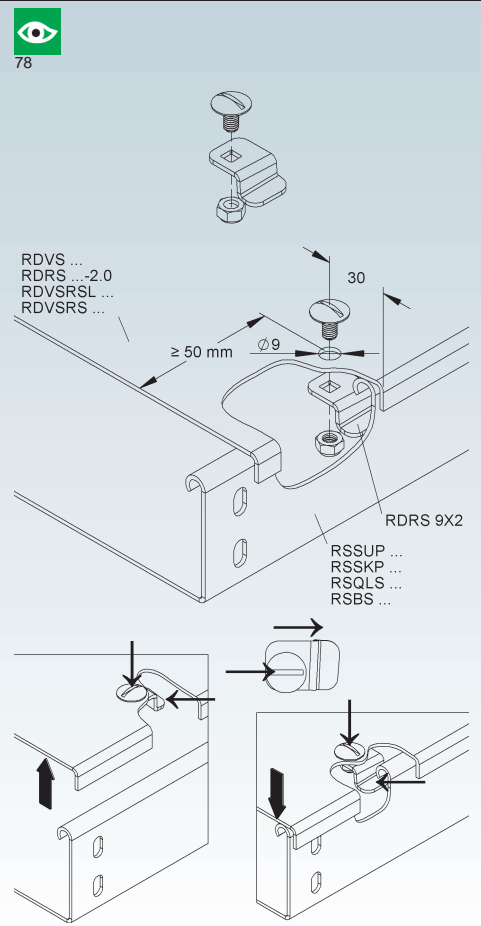

Turnbolt Lock

incl. locking nut

Model no.	Acc. incl.	Weight per 100 pcs kg	Pack/Box Qty
S RDRS 2	1 FL 6X12-S V, 1 SMS 6 V	1,3	100

Suitable for: all R-series fitting covers and RSV 50.100 distribution tray covers

Please maintain a 50 mm minimum distance from the edge of the cover for the turn-bolt installation. Not sufficient for securing covers to tray installed vertically or sideways nor for securing covers against windloads. Please use self tapping screws, steel cable ties or coverhinges in addition.

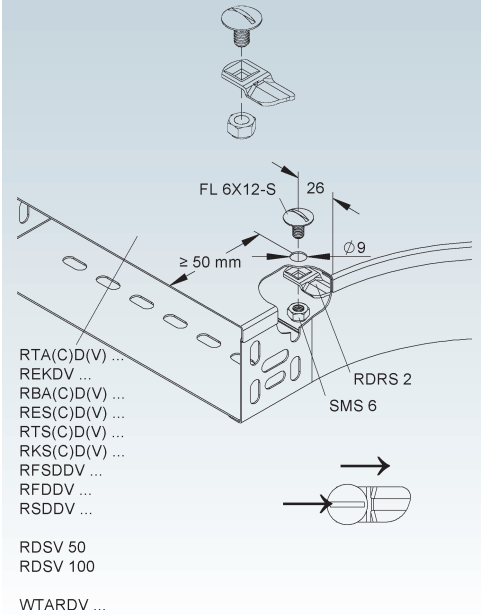

Heavy Duty Cover Clamp

Model no.	Weight per 100 pcs kg	Pack/Box Qty
VZL RDHFS 9 VZL	1,07	60

Suitable for: all heavy duty covers in S and F finish for cable trays and fittings as well as for vertical ladder enclosure panels

Please maintain a 50 mm minimum distance from the edge of the cover for the cover clamp installation.

Not sufficient for securing covers against windloads. Please use self tapping screws, steel cable ties or coverhinges in addition.

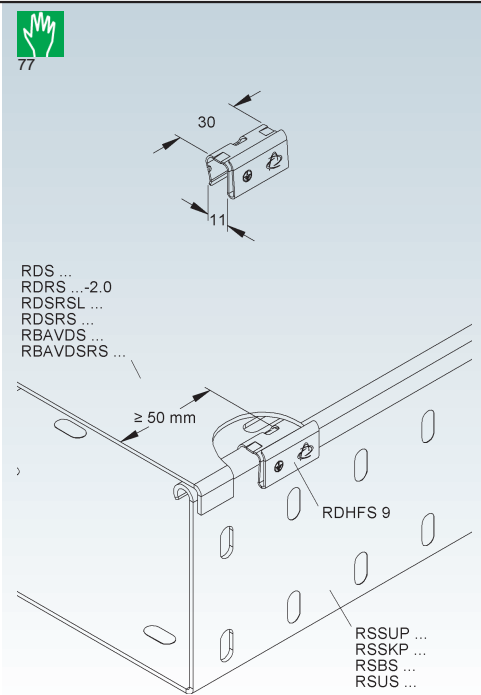

FLOOR-MOUNT CABLE TRAY SYSTEM

Dust Protection Strip

U-shaped

	Model no.	Width B		Thick-ness t	Weight per 100 pcs	Pack/Box Qty
		mm	Inch			
S	DSL 100-0.75 S	104	4,1	0,75	3,69	1
S	DSL 200-0.75 S	204	8	0,75	6,63	1
S	DSL 300-0.75 S	304	12	0,75	9,58	1
S	DSL 400-0.75 S	404	15,9	0,75	12,52	1
S	DSL 500-0.75 S	504	19,8	0,75	15,46	1
S	DSL 600-0.75 S	604	23,8	0,75	18,41	1

to be installed under straight joints of cable tray covers

Suitable for: all floor-mount tray covers

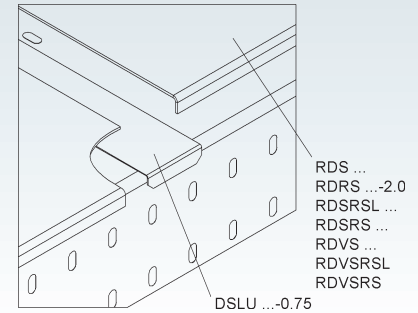
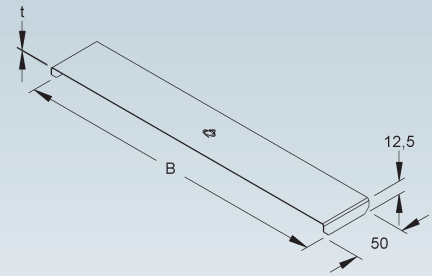

Cover Removing Tool

	Model no.	Thick-ness t	Weight per 100 pair	Pack/Box Qty
		mm	kg	
S	DHBKS 170 S	1,5	39,97	10 pair

to deinstall floor-mount tray covers

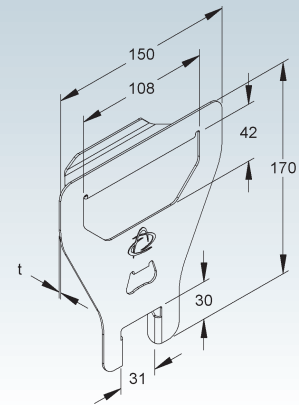

Bearing for Framing Channel

to support floor-mount tray covers with framing channel

	Model no.	Height H		Width B		Depth T	Thick-ness t	Acc. incl.	Weight per 100 pcs	Pack/Box Qty
		mm	Inch	mm	Inch					
S	TR 86 S	82	3,2	46	1,8	31	2	2 FLM 6X16 F	7,67	20

2 pieces per bearing required

Suitable for: framing channel 2986...

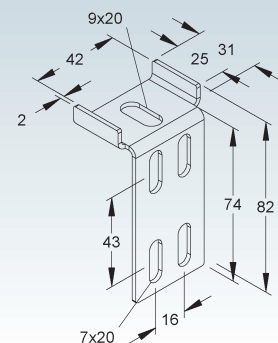
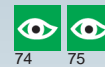

Tee-Connector

Model no.	Weight per 100 pcs kg	Pack/Box Qty
G TV 40	10,85	100

Suitable for: framing channel (width 40 mm) 2986...
hardware not included

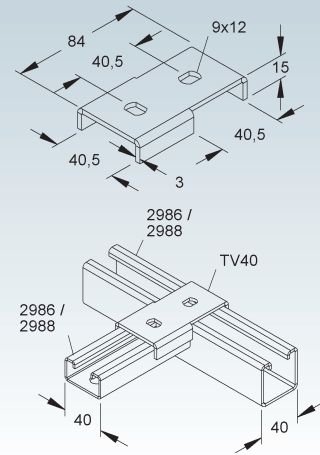

2986 Framing Channel

C-profile, slot width 18 mm, perforated, according to DIN EN 60715 standard

	Model no.	Length L		Perforation	Distance between drill holes		Weight per 100 pcs/m kg	Pack/Box Qty
		mm	Inch		mm	mm		
S	2986/100 SL	100	3,9	11,5x30	50	2	14,91	1
S	2986/200 SL	200	7,9	11,5x30	50	2	29,81	1
S	2986/300 SL	300	11,8	11,5x30	50	2	44,72	1
S	2986/400 SL	400	15,7	11,5x30	50	2	59,63	1
S	2986/500 SL	500	19,7	11,5x30	50	2	74,53	1
S	2986/600 SL	600	23,6	11,5x30	50	2	89,44	1
S	2986/3 SL	3000	118,1	11,5x30	50	2	149,07	5 x 3 m

matching yoke-clamp BUK...

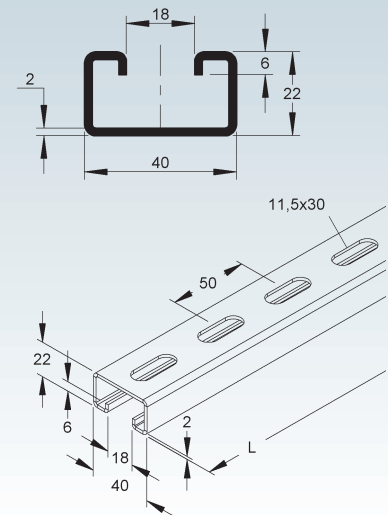
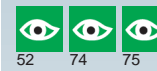

Floor Mounting Bracket (height: 50 mm)

with slotted holes

	Model no.	Height H		Width B	Thick-ness t	Acc. incl.	Weight per 100 pcs kg	Pack/Box Qty	
		mm	Inch						mm
S	RZP 50/100	50	2	100	3,9	2	2 FLM 6X12	18,06	10
S	RZP 50/200	50	2	200	7,9	2	2 FLM 6X12	34,50	10
S	RZP 50/300	50	2	300	11,8	2	2 FLM 6X12	50,95	10
S	RZP 50/400	50	2	400	15,7	2	2 FLM 6X12	67,39	10
S	RZP 50/500	50	2	500	19,7	2	2 FLM 6X12	83,84	10
S	RZP 50/600	50	2	600	23,6	2	2 FLM 6X12	100,28	10

Alternate mounting of Z-shaped bracket is strongly recommended.

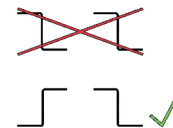
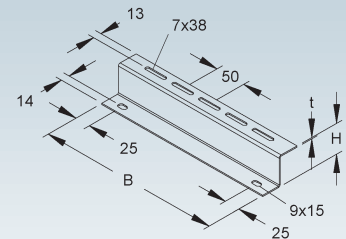

FLOOR-MOUNT CABLE TRAY SYSTEM

Floor Mounting Bracket (height: 100 mm)

with slotted holes

	Model no.	Height H		Width B		Thick-ness t mm	Acc. incl.	Weight per 100 pcs kg	Pack/Box Qty
		mm	Inch	mm	Inch				
S	RZP 100/100 S	102	4	100	3,9	2	2 FLM 6X12	26,06	10
S	RZP 100/200 S	102	4	200	7,9	2	2 FLM 6X12	50,52	10
S	RZP 100/300 S	102	4	300	11,8	2	2 FLM 6X12	74,97	10
S	RZP 100/400 S	102	4	400	15,7	2	2 FLM 6X12	99,42	10
S	RZP 100/500 S	102	4	500	19,7	2	2 FLM 6X12	123,87	10
S	RZP 100/600 S	102	4	600	23,6	2	2 FLM 6X12	148,32	10
S	RZP 100/3000 S	102	4	3000	118,1	2	2 FLM 6X12	732,66	1

Alternate mounting of Z-shaped bracket is strongly recommended.

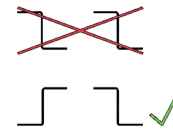
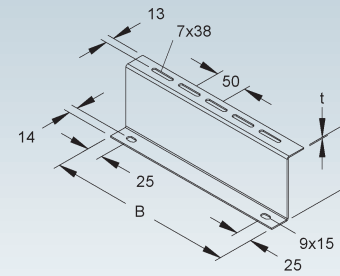

Floor Clamp

	Model no.	Width B		Length L	Thick-ness t mm	Weight per 100 pcs kg	Pack/Box Qty	
		mm	Inch					
V	RZPBL 25.90	25	1	90	3,5	3	4,9	50

for fixing premounted RZP... brackets to the floor

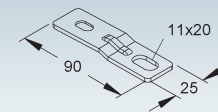

Floor Mounting Bracket

Z-shaped

	Model no.	Height H		Width B		Thick-ness t mm	Weight per 100 pcs kg	Pack/Box Qty
		mm	Inch	mm	Inch			
F	RSSZS 85.40 F	85	3,3	40	1,6	3	17,52	50
F	RSSZS 85.80 F	85	3,3	80	3,1	3	36,03	50
F	RSSZS 95.40 F	95	3,7	40	1,6	3	18,56	50
F	RSSZS 95.80 F	95	3,7	80	3,1	3	38,10	50

2 pieces required per supporting point

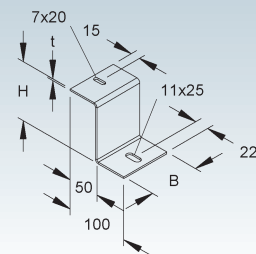

Skirting Panel

	Model no.	Height H		Length L		Thick-ness t mm	Weight per 100 m kg	Pack/Box Qty
		mm	Inch	mm	Inch			
S	VBASB 85-1.5/3000 S	85	3,3	3000	118,1	1,5	100,09	3 m
S	VBASB 95-1.5/3000 S	95	3,7	3000	118,1	1,5	111,86	3 m

for shielding the space underneath floor-mount cable trays

Suitable for: floor mounting brackets RSSZS 85... and 95...

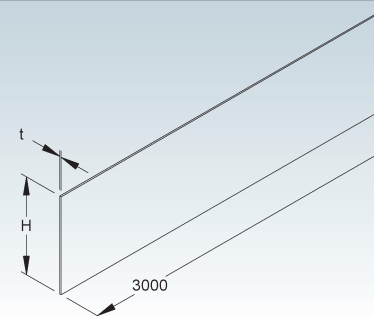

Retaining Clip for Skirting Panel

	Model no.	Height H		Width B		Length L	Thick-ness t mm	Weight per 100 pcs kg	Pack/Box Qty
		mm	Inch	mm	Inch				
E2	HKVB 85-110 E2	51,5	2	54,5	2,1	24	0,9	1,61	500

for attaching VBASB... skirting panels to RSSZS... floor mounting brackets

Suitable for: skirting panel VBASB 85... and 95...

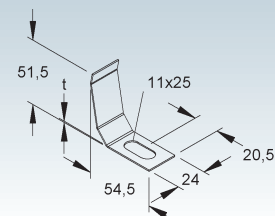

Floor Stand

Model no.	Height H	Width B	Length L	Thickness t	Acc. incl.	Weight per 100 pcs kg	Pack/Box Qty
	mm Inch	mm Inch	mm Inch	mm			
V RDB 85.100 V	85 3,3	100 3,9	50 2	5	2 FLM 6X16 F	60,3	1
V RDB 85.200 V	85 3,3	200 7,9	40 1,6	5	2 FLM 6X16 F	62,1	1
V RDB 85.300 V	85 3,3	300 11,8	40 1,6	5	2 FLM 6X16 F	77,8	1
V RDB 85.400 V	85 3,3	400 15,7	40 1,6	5	2 FLM 6X16 F	93,5	1
V RDB 85.500 V	85 3,3	500 19,7	40 1,6	5	2 FLM 6X16 F	109,2	1
V RDB 85.600 V	85 3,3	600 23,6	40 1,6	5	2 FLM 6X16 F	124,9	1

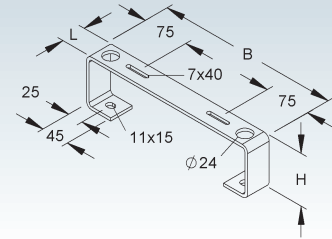

Skirting Panel

Model no.	Height H	Width B	Length L	Thickness t	Weight per 100 m kg	Pack/Box Qty
	mm Inch	mm Inch	mm Inch	mm		
S VBASB 92.8-1.5/3000 S	92 3,6	8,5 0,3	3000 118,1	1,5	115,27	3 m

for shielding the space underneath floor-mount cable trays

Suitable for: floor stand RDB 85...

Item also available in different heights

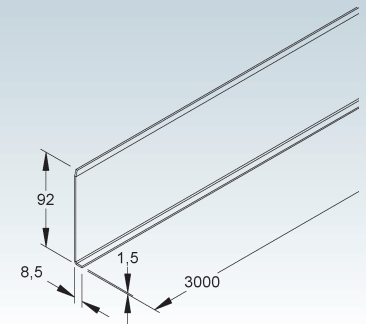

Floor Stand

asymmetric, solid channel with closed ends

Model no.	Height H	Width B	Dist. A	Dist. C	Weight per 100 pcs kg	Pack/Box Qty
	mm Inch	mm Inch	mm Inch	mm Inch		
V RSSTAU 108.100 V	108 4,3	92 3,6	12 0,5	60 2,4	86,75	1
V RSSTAU 108.200 V	108 4,3	192 7,6	12 0,5	160 6,3	103,52	1
V RSSTAU 108.300 V	108 4,3	292 11,5	18 0,7	234 9,2	125,32	1
V RSSTAU 108.400 V	108 4,3	392 15,4	18 0,7	334 13,1	142,10	1
V RSSTAU 108.500 V	108 4,3	492 19,4	118 4,6	334 13,1	158,87	1
V RSSTAU 108.600 V	108 4,3	592 23,3	218 8,6	334 13,1	175,65	1

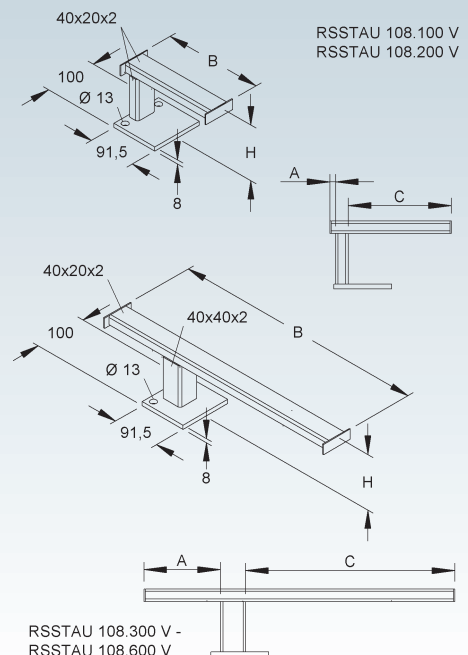

FLOOR-MOUNT CABLE TRAY SYSTEM

Skirting Panel

Model no.	Height H mm Inch	Width B mm Inch	Length L mm Inch	Thick- ness t mm	Weight per 100 m kg	Pack/ Box Qty
S VBASB 106.7-2.0/3000 S	106 4,2	7 0,3	3000 118,1	2	172,59	3 m

for shielding the space underneath floor-mount cable trays

Suitable for: floor stand RSSTAU 108...

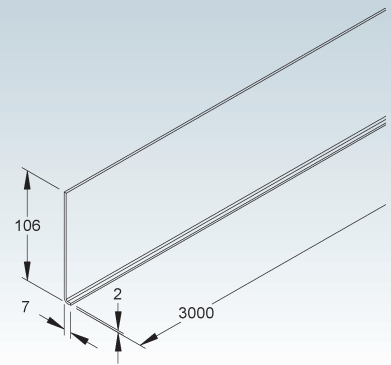

Large Diameter Washer

Model no.	Inner diameter mm Inch	mm	Thick- ness t mm	Weight per 100 pcs kg	Pack/ Box Qty
V UGM 8	8,4 0,3	24	2	0,68	100
E3 UGM 8 E3	8,4 0,3	24	2	0,68	100

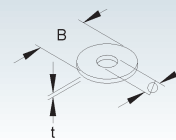

Carriage Bolt with Nut

serrated flange nut included

Model no.	Thread M	Length L mm Inch	Strength category	Weight per 100 pcs kg	Pack/ Box Qty
V FLM 6X12	6	12 0,5	-	0,79	100
F FLM 8X16 F	8	16 0,6	8.8	2,09	50

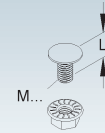

Pan-Head Torx Bolt

serrated flange nut included

Model no.	Thread M	Length L mm Inch	Strength category	Weight per 100 pcs kg	Pack/ Box Qty
V LFM 6X16-TX V	6	16 0,6	-	0,88	50

for fitting cable trays on spacer plates/brackets and for fitting dividers, etc.

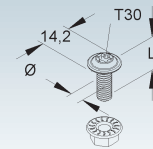

Self-Tapping Screw with Pan-Head

Model no.	Thread M	Length L mm Inch	Strength category	Weight per 100 pcs kg	Pack/ Box Qty
V B 4.2X13-TX V	4,2	13 0,5	-	0,18	1000

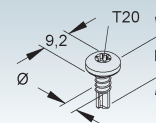

Expansion Anchor

Approval No.: ETA-18/0542, with nut and large washer

Model no.	Connection thread metric	Length L mm Inch	Diameter drillhole mm	Washer diameter mm	Clamping range t fix mm	Effective anchoring depth h ef mm	Weight per 100 pcs kg	Pack/ Box Qty
V DAZ 8X10	8	75 3	8	24	≤ 10	45	3,16	50
V DAZ 10X10	10	95 3,7	10	25	≤ 10	60	6,33	50
V DAZ 12X10	12	110 4,3	12	30	≤ 10	70	10,27	20

Please always follow the enclosed installation instructions and contact Niedax for detailed technical specifications.

Recommended Torque:

DAZ 8X10 - tightening torque 20 Nm

DAZ 10X10 - tightening torque 45 Nm

DAZ 12X10 - tightening torque 60 Nm

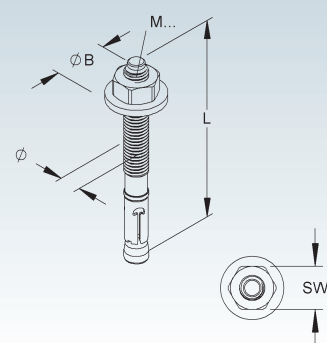

Concrete Screw Anchor

Approval No.: ETA 15/0784, Torx T30 large diameter pan-head

Model no.	Diameter (Ø) mm	Length L mm Inch	Drive size	Diameter drillhole mm	Max. mounting thickness mm	Weight per 100 pcs kg	Pack/Box Qty
V NSA 7.5X50/FGK-T30 V	7,5	50 2	T30	6	15	1,62	100

for indoor use only

Suitable for: mounting e.g. framing channel

Recommended screw tightening torque 20 Nm



48

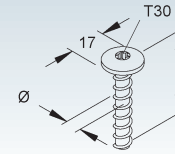

CABLE TRAY SYSTEM





CABLE LADDER SYSTEM

- Cable Ladder
- Covers
- Fittings
- Accessories

Cable ladders are ideal to install large volumes of heavy duty power cables. The long rung spacing means full free air rating of cables. Higher current flow can be achieved at the same cable cross-section. Overheating and consecutive damaging of cables is avoided. The new shape of the side rail allows higher cable loads at similar support spans, the continuous perforation in the siderails guarantees easy mounting of fittings. Cables can be installed and fixed to the rungs using appropriate yoke clamps. Niedax Cable ladders can be slit together to minimize transport and storage volume needs.

All straight sections of cable tray as well as their corresponding system components (fittings, splice plates, covers, ...) are classified by UL in accordance with NEMA VE 1 for the USA and CSA C22.1 No. 126.1 for Canada. An ‚X‘ in the part number will be added for labeling according to UL instructions (see catalog page 40).



CABLE LADDER SYSTEM

Available Side Rail Heights

SYSTEM	Cable Ladder	KL...	Page 264
ACCESSORIES	Splice Plate	KSV 100 S	Page 264
	Adjustable Splice Plate	KGV 100 S	Page 264
	Adjustable Splice Plate	KWV 100 S	Page 265
	Divider	RW 85	Page 265
	Splice Plate for Divider	RTV 85 E2	Page 265
	Mounting Clamp for Divider	KLWC 16	Page 265
	Horizontal Elbow 90°, small radius	KLBK...	Page 265
	Extension Horizontal Tee	KLTA...	Page 266
	Protective End Cap	SKSP 70	Page 266
	Horizontal Tee	KLT...	Page 266
	Adjustable Vertical Elbow	KGS...	Page 267
	Cable Ladder Connection Bracket	KLAS 100	Page 267
	Pair of Protective End Caps	SKK 100	Page 267
	Ladder Drop Out	KLAB...	Page 267
	Cable Ladder Mounting Bracket	KLTB 6	Page 268
	Cable Ladder Mounting Bracket	KLTB 96 F	Page 268
	Two Hole Corner Angle	WWU 150/8	Page 268
	Three Hole Corner Angle	WWA 100	Page 268
	Cover for Cable Tray/Ladder	RDV...	Page 269
	Cover for 90° Horizontal Elbow, small radius	KLBKDV...	Page 269
	Cover for Horizontal Tee	KLTDV...	Page 269
	Turnbolt Lock	RDRS 9	Page 269
	Raised Cover Clamp	RDAH 30...	Page 270

CABLE LADDER SYSTEM

Cable Ladder Specifications:

A. CABLE TRAY DESIGN

1. Cable Tray shall be made of straight sections, fittings and accessories as defined in the latest NEMA standards per NEMA VE-1. Standard cable trays shall be UL classified as equipment grounding conductors.

B. MATERIAL

1. **Pre-galvanized steel.** The structural quality of the steel shall meet the minimum yield and tensile strength of the ASTM standards (ASTM A 653) with G 90 coating thickness.
All cable trays to be labeled for material identification purposes.
2. **Hot dipped galvanized steel.** All trays to be hot-dipped galvanized in accordance with ASTM A123.
All trays to be labeled for material identification.
3. **Stainless steel.** All trays are to be constructed of AISA type 304 or 316 stainless steel.
All trays to be labeled for material identification.

C. TRAY TYPES

1. **Ladder cable tray.** Ladder shall consist of two side-rails with rungs riveted to the bottom flange of the side-rails. Rungs shall be spaced 8" or 12" (200 or 300 mm) on center. Rungs shall not protrude below the bottom of the side-rail.

D. TRAY SIZE

1. **Height:** Ladder shall have an overall height of 4" (100 mm).
Minimum load depth shall be 3.5" (90 mm).
2. **Width:** Widths shall be 8", 12", 16", 20" and 24" (200, 300, 400, 500 and 600 mm)
3. **Length:** Length shall be a nominal 10' or 3 meters and 20' or 6 meters

E. ACCESSORIES

1. **Covers.** Covers shall be supplied to protect tray cable where needed. Covers will be solid and contain three pair of turn-bolt locks to secure the covers to the lips of the cable tray, requiring only the use of a slotted screwdriver.
2. **Splice plates.** Splice plates shall fasten to the outside of the cable tray side-rails and wrap around and snap onto each section of tray. Bolts and nuts are used to fasten to the tray and are included with splice plates.
Plates shall not exceed the NEMA VE-1 resistance of 330 micro ohms.
3. **Other accessories** shall be furnished as required to protect, support, and install a cable tray system.
Fittings shall made of the same material as the cable tray whenever possible.
Fittings can be of factory construction or also be of a type that allows field constructed fittings.

F. LOADING CAPABILITIES

1. Cable tray shall meet the load/span class designation in accordance with NEMA VE 1 and CSA E22.2 No 126.1.
Cable tray shall also meet load/span designation in accordance with IEC 61537

G. DESIGN AND MANUFACTURE

1. Cable tray design shall be manufactured by The Niedax Group.

**Load/Span Class Designation in accordance
with NEMA VE 1 and CSA C22.2 No. 126.1**

Niedax Series	Minimum Area		Load class in accordance to NEMA VE 1		
	(calculational) mm ² / in. ²	in accordance to NEMA VE 2 mm ² / in. ²	Rated Load Kg/m / lb./ft.	Support spacing m / ft.	Load/Span Class
KLX 100.203/3-2970 S	414.0 / 0.64	258 / 0.4	107 / 72	2 / 6.6	5A, A
KLX 100.303/3-2970 S	414.0 / 0.64	258 / 0.4	107 / 72	2 / 6.6	5A, A
KLX 100.403/3-2970 S	414.0 / 0.64	258 / 0.4	107 / 72	2 / 6.6	5A, A
KLX 100.503/3-2970 S	414.0 / 0.64	258 / 0.4	107 / 72	2 / 6.6	5A, A
KLX 100.603/3-2970 S	414.0 / 0.64	258 / 0.4	107 / 72	2 / 6.6	5A, A



CABLE LADDER SYSTEM

Cable Ladder

C-channel rungs with 16 mm slot width, standard spacing 300 mm

	Model no.	Height H		Width B		Length L		Thick-ness t mm	Weight per 100 m kg	Pack/Box Qty
		mm	Inch	mm	Inch	mm	Inch			
S	KL 100.203/3-2970 S	100	3,9	200	7,9	3000	118,1	1,5	361,92	3 m
S	KL 100.303/3-2970 S	100	3,9	300	11,8	3000	118,1	1,5	387,08	3 m
S	KL 100.403/3-2970 S	100	3,9	400	15,7	3000	118,1	1,5	412,25	3 m
S	KL 100.503/3-2970 S	100	3,9	500	19,7	3000	118,1	1,5	437,40	3 m
S	KL 100.603/3-2970 S	100	3,9	600	23,6	3000	118,1	1,5	462,54	3 m

KSV 100... splice plates have to be ordered separately.
matching yoke-clamp BK...

Load Chart: q = uniformly distributed load (tested according to DIN EN IEC 61537 standard)

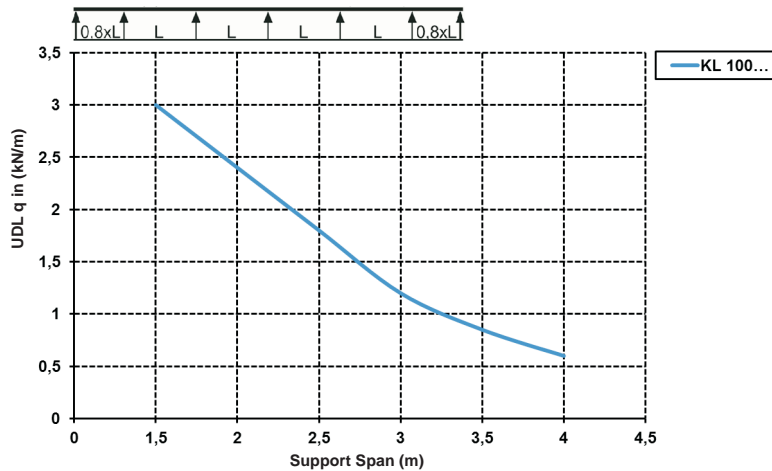

Specified load ratings are independent of splice plate location.

Height 100 mm
Nominal 4 inches

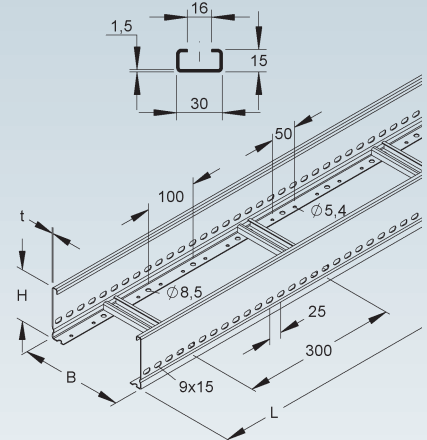

Splice Plate

	Model no.	Height H		Acc. incl.	Weight per 100 pcs kg	Pack/Box Qty
		mm	Inch			
S	KSV 100 S	100	3,9	2 FLM 8X13 F	26,37	10

form-locking straight splice plate for cable ladders
UL classified splice plates ensure electrical continuity and proper bonding.

Height 100 mm
Nominal 4 inches

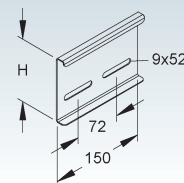

Adjustable Splice Plate

vertical

	Model no.	Height H		Acc. incl.	Weight per 100 pcs kg	Pack/Box Qty
		mm	Inch			
S	KGV 100 S	100	3,9	2 FLM 8X13 F	53,21	10

2 pieces required per joint
UL classified splice plates ensure electrical continuity and proper bonding.

Height 100 mm
Nominal 4 inches

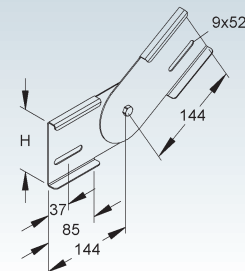

Adjustable Splice Plate

horizontal

Model no.	Height H mm Inch	Acc. incl.	Weight per 100 pcs kg	Pack/Box Qty
S KVV 100 S	100 3,9	4 FLM 8X13 F	54,87	10

2 pieces required per joint

UL classified splice plates ensure electrical continuity and proper bonding.

Height
100 mm
Nominal
4 inches

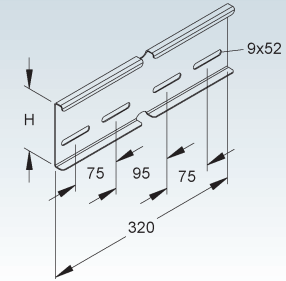

Divider

Model no.	Height H mm Inch	Thickness t mm	Acc. incl.	Weight per 100 m kg	Pack/Box Qty
S RW 85	80 3,1	0,9	4 FLM 6X12	77,65	10 x 3 m

to separate wires and cables of different voltage levels or with different functions

Height
85 mm
Nominal
3 3/8 inches
69

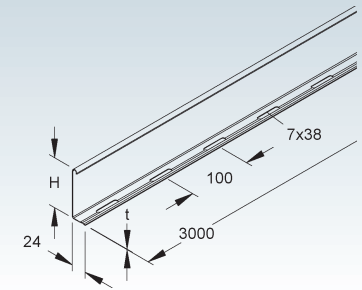

Splice Plate for Divider

Model no.	Height H mm Inch	Length L mm Inch	Weight per 100 pcs kg	Pack/Box Qty
E2 RTV 85 E2	79,5 3,1	80 3,1	2,03	20

for positive locking connections and proper bonding of dividers

Height
85 mm
Nominal
3 3/8 inches
69

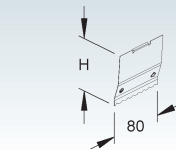

Mounting Clamp for Divider

Model no.	Acc. incl.	Weight per 100 pcs kg	Pack/Box Qty
S KLWC 16	1 FK 6X12 V, GSM 406 G	2,64	50

Suitable for: divider RW...

69

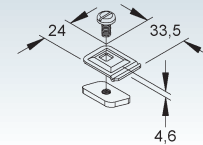

Horizontal Elbow 90° (small radius)

with perforated siderails

Model no.	Height H mm Inch	Width B mm Inch	Weight per 100 pcs kg	Pack/Box Qty
S KLBK 100.203	100 3,9	200 7,9	468,08	1
S KLBK 100.303	100 3,9	300 11,8	534,27	1
S KLBK 100.403	100 3,9	400 15,7	600,52	1
S KLBK 100.503	100 3,9	500 19,7	666,74	1
S KLBK 100.603	100 3,9	600 23,6	732,91	1

This product is built with 2970 rungs (w=30 mm, h=15 mm, t=1.5 mm, slot width 16 mm).
KSV 100... splice plates have to be ordered separately.

Height
100 mm
Nominal
4 inches

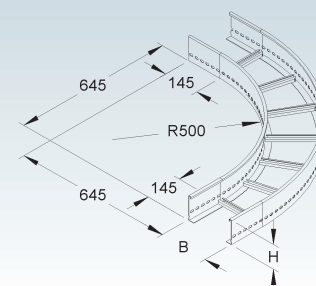

CABLE LADDER SYSTEM

Extension Horizontal Tee

with perforated siderails

	Model no.	Height H		Width B		Weight per 100 pcs kg	Pack/Box Qty
		mm	Inch	mm	Inch		
S	KLTA 100.203	100	3,9	200	7,9	550,86	1
S	KLTA 100.303	100	3,9	300	11,8	576,56	1
S	KLTA 100.403	100	3,9	400	15,7	601,18	1
S	KLTA 100.503	100	3,9	500	19,7	625,68	1
S	KLTA 100.603	100	3,9	600	23,6	650,19	1

This product is built with 2970 rungs (w=30 mm, h=15 mm, t=1.5 mm, slot width 16 mm).
KSV 100... splice plates have to be ordered separately.

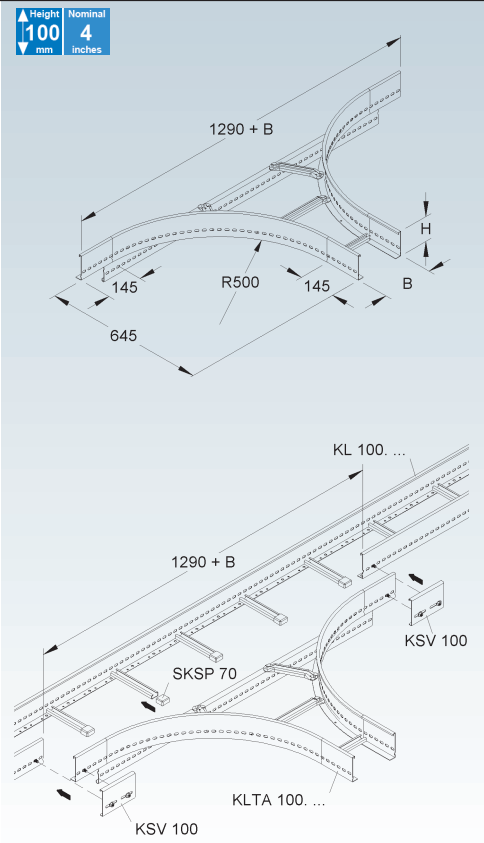

Protective End Cap

	Model no.	Height H		Color	Weight per 100 pcs kg	Pack/Box Qty
		mm	Inch			
K04	SKSP 70	15	0,6	grey	0,57	20

Suitable for: framing channel 2970... and SP 70 rungs

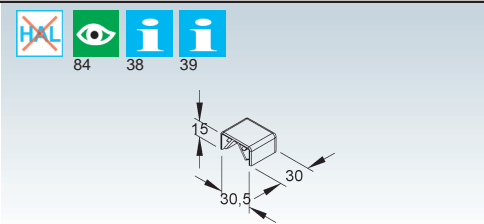

Horizontal Tee

with perforated siderails

	Model no.	Height H		Width B		Weight per 100 pcs kg	Pack/Box Qty
		mm	Inch	mm	Inch		
S	KLT 100.203	100	3,9	200	7,9	869,88	1
S	KLT 100.303	100	3,9	300	11,8	953,28	1
S	KLT 100.403	100	3,9	400	15,7	1.035,59	1
S	KLT 100.503	100	3,9	500	19,7	1.117,79	1
S	KLT 100.603	100	3,9	600	23,6	1.245,39	1

This product is built with 2970 rungs (w=30 mm, h=15 mm, t=1.5 mm, slot width 16 mm).
KSV 100... splice plates have to be ordered separately.

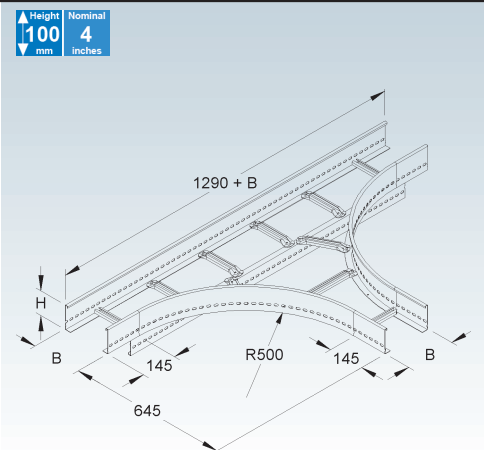

Adjustable Vertical Elbow

vertical

	Model no.	Height H		Width B		Acc. incl.	Weight per 100 pcs kg	Pack/Box Qty
		mm	Inch	mm	Inch			
S	KGS 100.203	100	3,9	200	7,9	16 FLM 8X13 F	660,83	1
S	KGS 100.303	100	3,9	300	11,8	16 FLM 8X13 F	684,50	1
S	KGS 100.403	100	3,9	400	15,7	16 FLM 8X13 F	708,18	1
S	KGS 100.503	100	3,9	500	19,7	16 FLM 8X13 F	731,85	1
S	KGS 100.603	100	3,9	600	23,6	16 FLM 8X13 F	755,53	1

This product is built with 2970 rungs (w=30 mm, h=15 mm, t=1.5 mm, slot width 16 mm).
Delivered as a kit (not assembled).

Height
100 mm
Nominal
4 inches

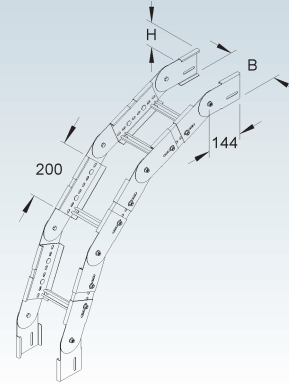

Cable Ladder Connection Bracket

	Model no.	Height H		Acc. incl.	Weight per 100 pcs kg	Pack/Box Qty
		mm	Inch			
F	KLAS 100	100	3,9	1 KLTB 6 F	20,51	20

cable ladder connector bracket for field made horizontal tees

Height
100 mm
Nominal
4 inches

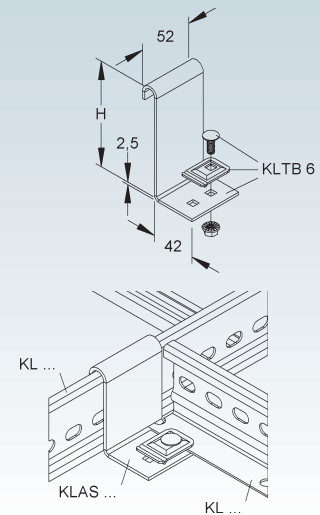

Pair of Protective End Caps

	Model no.	Height H		Color	Weight per 100 pair kg	Pack/Box Qty
		mm	Inch			
K10	SKK 100	100	3,9	yellow	5	10 pair

Suitable for: cable ladder KL...

Height
100 mm
Nominal
4 inches

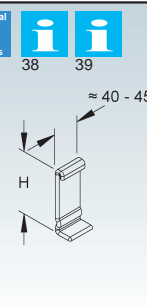

Ladder Drop Out

with rounded edges

	Model no.	Width B		Acc. incl.	Weight per 100 pcs kg	Pack/Box Qty
		mm	Inch			
S	KLAB 200	190	7,5	2 FK 6X12, 2 GSM 306	40,89	1
S	KLAB 300	290	11,4	2 FK 6X12, 2 GSM 306	63,64	1
S	KLAB 400	390	15,4	2 FK 6X12, 2 GSM 306	86,39	1
S	KLAB 500	490	19,3	2 FK 6X12, 2 GSM 306	143,41	1
S	KLAB 600	590	23,2	2 FK 6X12, 2 GSM 306	173,46	1

Suitable for: cable ladder KL...

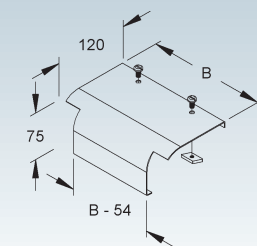

CABLE LADDER SYSTEM

Cable Ladder Mounting Bracket

Model no.	Acc. incl.	Weight per 100 pcs kg	Pack/Box Qty
S KLTB 6	1 FLM 6X16 F	2,13	50

hold down clamp to fix cable ladders on brackets

2 pieces required per bracket

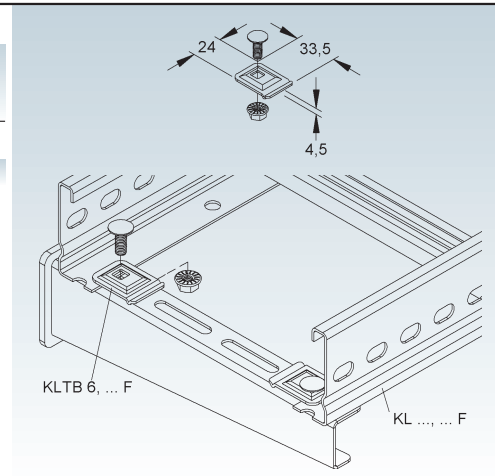

Cable Ladder Mounting Bracket

Model no.	Acc. incl.	Weight per 100 pcs kg	Pack/Box Qty
F KLTB 96 F	1 GMZF M6-22 F, 1 SK 6X20 F, 1 US M 6 F	5,44	50

2 pieces required per bracket

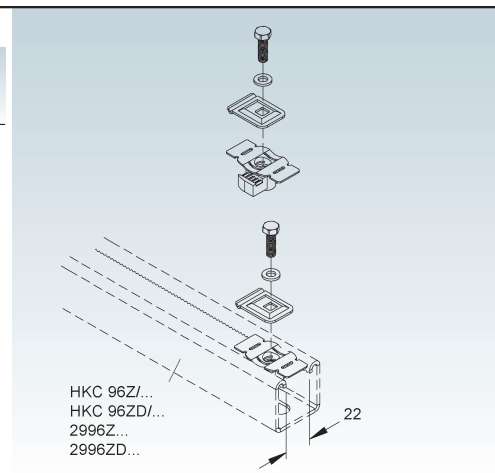

Two Hole Corner Angle

Model no.	Thickness t mm	Acc. incl.	Weight per 100 pcs kg	Pack/Box Qty
F WWU 150/8	5	1 FLM 8X16 F	19,11	50

for floor-, ceiling- or wall-mounting

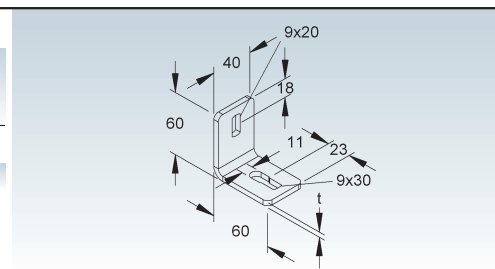

Three Hole Corner Angle

Model no.	Width B mm Inch	Thickness t mm	Acc. incl.	Weight per 100 pcs kg	Pack/Box Qty
F WWA 100	50 2	5	1 FLM 10X25 F	24,98	50

for floor-, ceiling- or wall-mounting

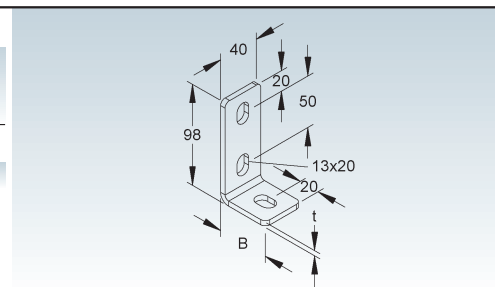

Cover for Cable Tray/Ladder

with turnbolt locks

Model no.	Inside dimension B mm Inch	Weight per 100 m kg	Pack/Box Qty
S RDV 200	202 8	133,44	2 x 3 m
S RDV 300	302 11,9	231,02	2 x 3 m
S RDV 400	402 15,8	335,56	2 x 3 m
S RDV 500	502 19,8	414,60	2 x 3 m
S RDV 600	602 23,7	493,63	2 x 3 m

Suitable for: all straight sections of cable tray (other than RSV 50...) as well as for cable ladders KL...
For outdoor service covers need to be secured against windloads using heavy duty cover clamps or steel cable ties.

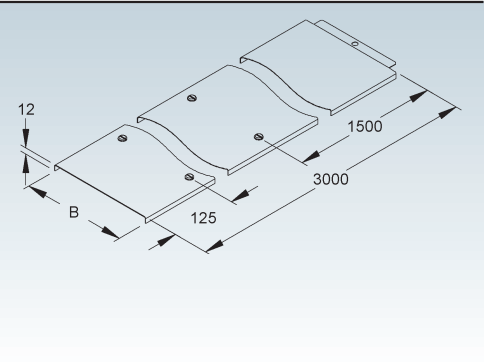

Cover for 90° Horizontal Elbow (small radius)

with turnbolt locks

Model no.	Inside dimension B mm Inch	Weight per 100 pcs kg	Pack/Box Qty
S KLBKDV 200	203 8	202,76	1
S KLBKDV 300	303 11,9	317,53	1
S KLBKDV 400	403 15,9	444,62	1
S KLBKDV 500	503 19,8	584,04	1
S KLBKDV 600	603 23,7	735,79	1

Suitable for: horizontal elbows 90° (small radius) KLBK...

For outdoor service covers need to be secured against windloads using heavy duty cover clamps or steel cable ties.

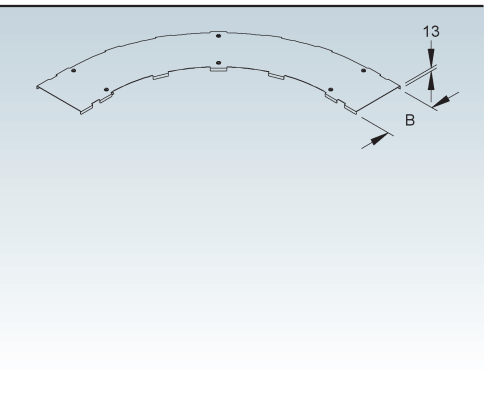

Cover for Horizontal Tee

with turnbolt locks

Model no.	Inside dimension B mm Inch	Weight per 100 pcs kg	Pack/Box Qty
S KLTDV 200	203 8	444,10	1
S KLTDV 300	303 11,9	636,22	1
S KLTDV 400	403 15,9	844,03	1
S KLTDV 500	503 19,8	1.067,55	1
S KLTDV 600	603 23,7	1.306,77	1

Suitable for: horizontal tees KLT...

For outdoor service covers need to be secured against windloads using heavy duty cover clamps or steel cable ties.

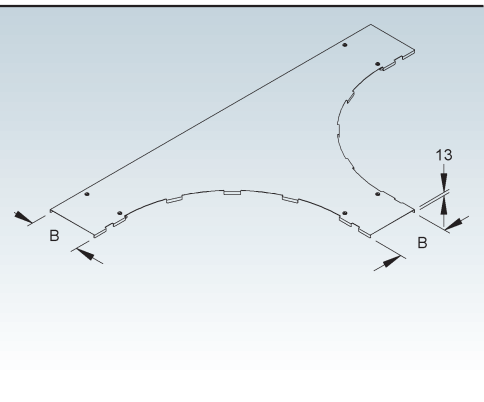

Turnbolt Lock

incl. locking nut

Model no.	Acc. incl.	Weight per 100 pcs kg	Pack/Box Qty
S RDRS 9	1 FL 6X12-S V, 1 SMS 6 V	1,2	100

Suitable for: cover RDV...

Please maintain a 50 mm minimum distance from the edge of the cover for the turn-bolt installation. Not sufficient for securing covers to tray installed vertically or sideways nor for securing covers against windloads. Please use self tapping screws, steel cable ties or coverhinges in addition.

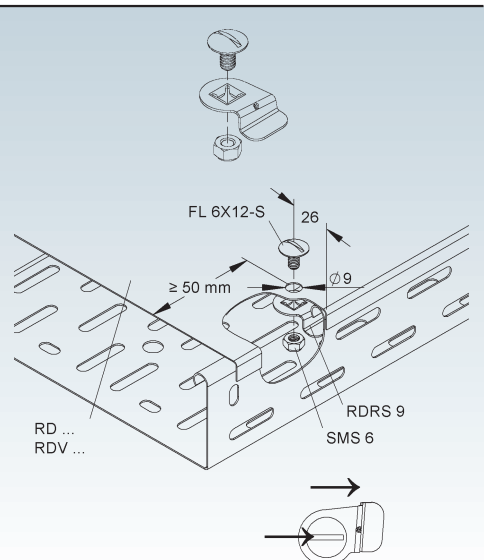

CABLE LADDER SYSTEM ACCESSORIES

Raised Cover Clamp

spacer block with hold down bracket

	Model no.	Height H		Width B		Thick-ness t mm	Acc. incl.	Weight per 100 pcs kg	Pack/Box Qty
		mm	Inch	mm	Inch				
S	RDH 30 S	122,5	4,8	40	1,6	1,5	2 FLM 6X12, 2 FLM 8X16 F	16,32	10
E3	RDH 30 E3	122,5	4,8	40	1,6	1,5	2 FLM 6X12 E3, 2 FLM 8X16 E3	16,22	10

to elevate RD- and WDV-series covers for improved ventilation can be installed on all R-Series cable trays and all KL/WSL/WRL-series cable ladders with a minimum side rail height of 50 mm

Three pairs required for every 3-meter section of covers.

Suitable for: ventilated RL/RS cable trays, KL ladders, and WRL/WSL cable trays & ladders

Six cover clamps are required for any 3-meter piece of cover.

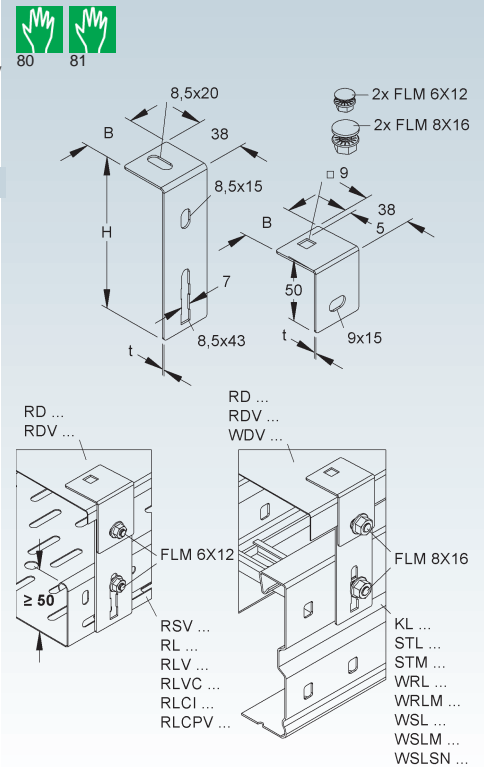

NOTES

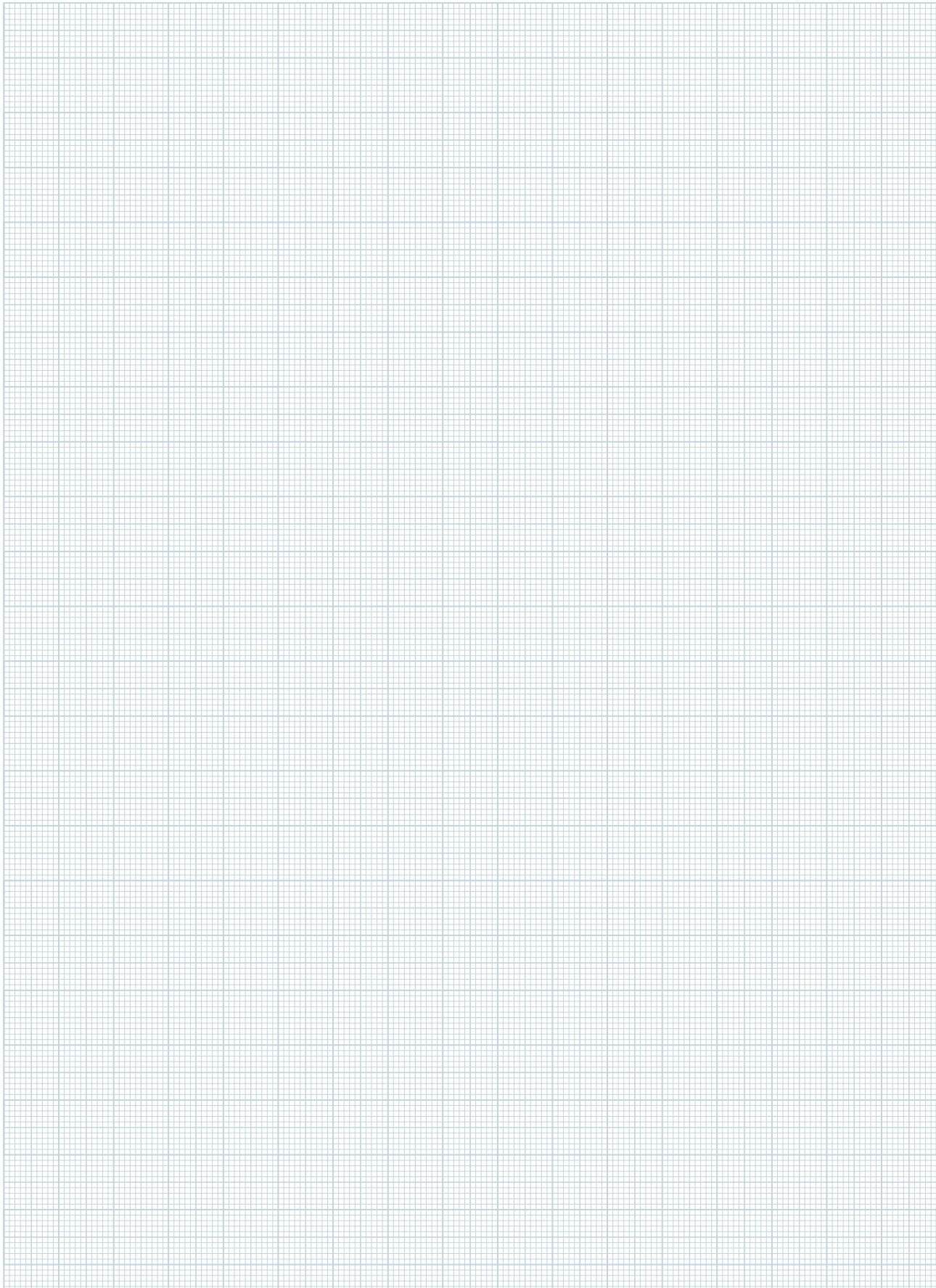

CABLE TRAY SYSTEM



VERTICAL CABLE LADDER SYSTEM

- Vertical Cable Ladder
- Accessories
- Splice Plates

Niedax vertical cable ladders are available in a wide range of sizes and finishes. They are designed to mount cables directly to the horizontal rungs using various kinds and sizes of Niedax yoke clamps. Light and medium duty versions can be bolted directly to the wall, the heavy duty version based on the I 80 profile is mounted using a wall support bracket.

All straight sections of cable tray as well as their corresponding system components (fittings, splice plates, covers, ...) are classified by UL in accordance with NEMA VE 1 for the USA and CSA C22.1 No. 126.1 for Canada.

An 'X' in the part number will be added for labeling according to UL instructions (see catalog page 40).



VERTICAL CABLE LADDER SYSTEM

Available Side Rail Heights

Height	Nominal	Height	Nominal
60	2 3/8	80	3
mm	inches	mm	inches

SYSTEM	Vertical Cable Ladder	STUC...	Page 276
	Vertical Cable Ladder	STIC...	Page 278
ACCESSORIES	Rungs for Vertical Cable Ladders	SPCKL...	Page 276
	Mounting Clamp for Divider	KLWC 18 F	Page 276/279
	Straight Splice Plate	VB 6040	Page 277
	Profile U 6040	U 6040...	Page 277
	Protective End Cap	SKU 6040	Page 277
	Two Hole Corner Angle	WWU 150	Page 277
	Three Hole Corner Angle	WWA 100	Page 278
	Rungs for Vertical Cable Ladders	SPC 86/...	Page 279
	Straight Splice Plate	VBI 80	Page 279
	Head Plate	KI 80	Page 279
	Head Plate	KIQ 80	Page 279
	Profile I 80	I 80/...	Page 280
	Protective End Cap	SKI 80	Page 280
	Two Hole Corner Angle for I 80	WWI 80	Page 280
	Enclosure Panel Kit for Vertical Ladder	STVWA...	Page 281
	Enclosure Panel Kit for Vertical Ladder	STVFA...	Page 281
	Mounting Kit for Enclosure Panel	STVDP 30.43...	Page 281
	Heavy Duty Cover Clamp	RDHFS 9 VZL	Page 282



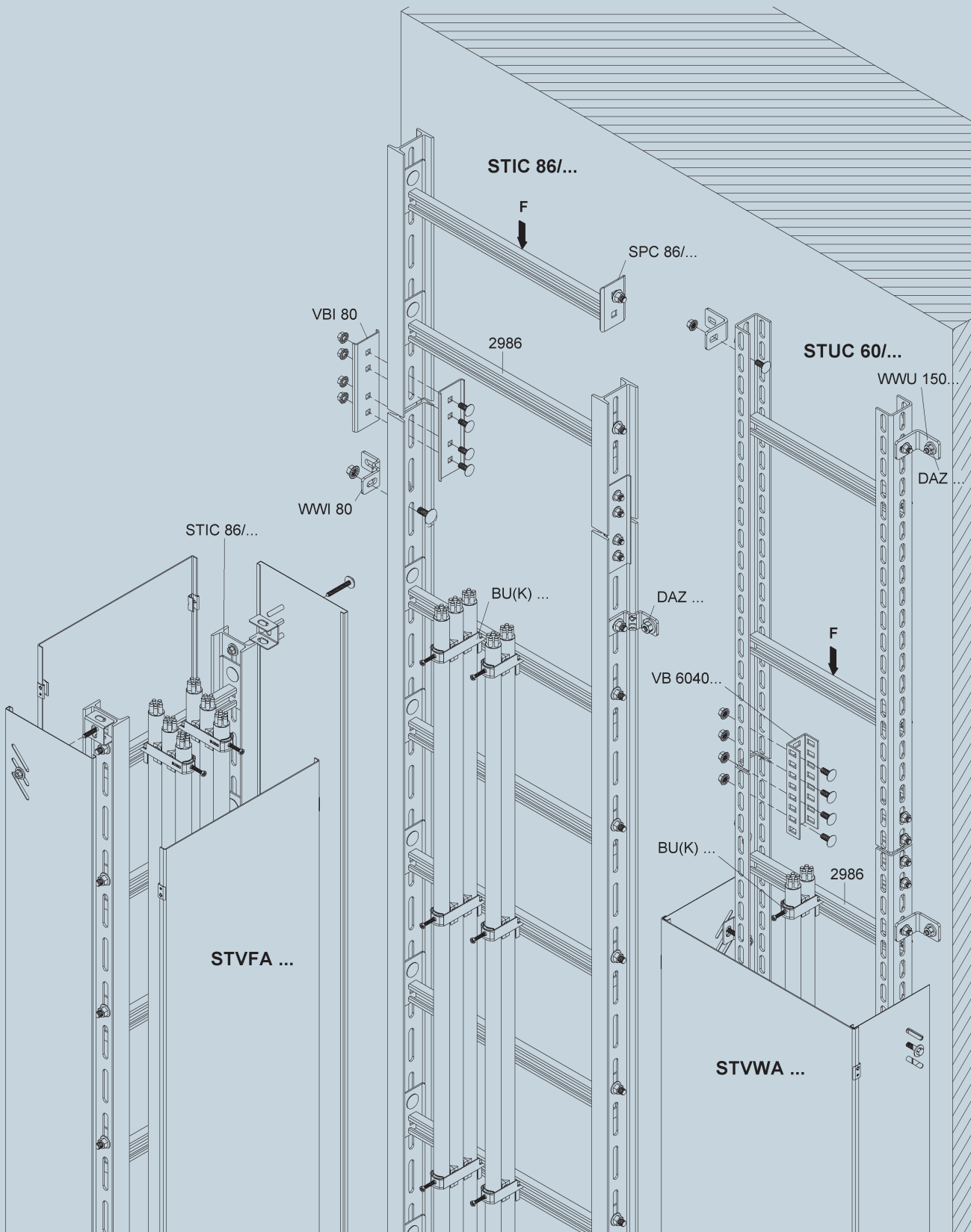

VERTICAL CABLE LADDER SYSTEM

Vertical Cable Ladder

delivered as a kit (not assembled)

	Model no.	Height H		Width B		Length L		Max. load F	Weight per 100 m kg	Pack/Box Qty
		mm	Inch	mm	Inch	mm	Inch			
F	STUC 60/205 F	60	2,4	215	8,5	4500	177,2	1,75	752,90	4,5 m
F	STUC 60/305 F	60	2,4	315	12,4	4500	177,2	1,75	785,78	4,5 m
F	STUC 60/405 F	60	2,4	415	16,3	4500	177,2	1,75	818,66	4,5 m
F	STUC 60/505 F	60	2,4	515	20,3	4500	177,2	1,75	851,55	4,5 m
F	STUC 60/605 F	60	2,4	615	24,2	4500	177,2	1,75	884,43	4,5 m
F	STUC 60/705 F	60	2,4	715	28,1	4500	177,2	1	917,31	4,5 m
F	STUC 60/805 F	60	2,4	815	32,1	4500	177,2	1	950,20	4,5 m
F	STUC 60/905 F	60	2,4	915	36	4500	177,2	1	983,08	4,5 m
F	STUC 60/1005 F	60	2,4	1015	40	4500	177,2	1	1.015,96	4,5 m
F	STUC 60/1105 F	60	2,4	1115	43,9	4500	177,2	1	1.048,85	4,5 m
F	STUC 60/1205 F	60	2,4	1215	47,8	4500	177,2	1	1.081,73	4,5 m

50 mm center distance for punch holes 13x40 mm on all 3 sides of the rail

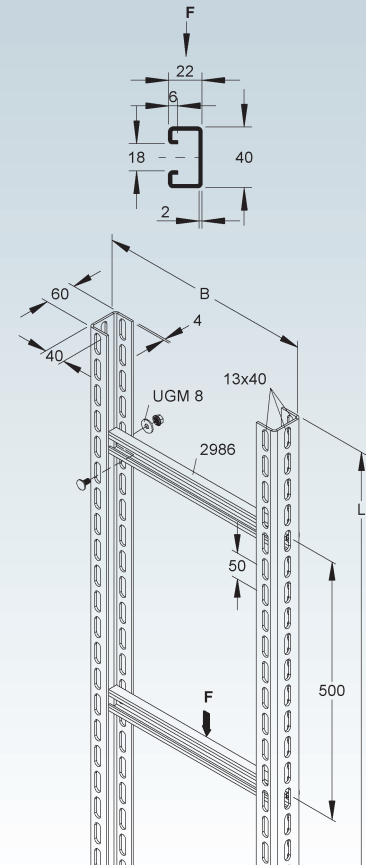

Rungs for Vertical Cable Ladders

C-rail type 2986 (40x22x2 mm), for additional needs

	Model no.	Width B		Max. load F	Acc. incl.	Weight per 100 pcs kg	Pack/Box Qty
		mm	Inch				
F	SPCKL 86/200 F	200	7,9	1,75	2 FLM 8X16 F, 2 UGM 8 F	37,96	1
F	SPCKL 86/300 F	300	11,8	1,75	2 FLM 8X16 F, 2 UGM 8 F	54,40	1
F	SPCKL 86/400 F	400	15,7	1,75	2 FLM 8X16 F, 2 UGM 8 F	70,85	1
F	SPCKL 86/500 F	500	19,7	1,75	2 FLM 8X16 F, 2 UGM 8 F	87,29	1
F	SPCKL 86/600 F	600	23,6	1,75	2 FLM 8X16 F, 2 UGM 8 F	103,73	1
F	SPCKL 86/700 F	700	27,6	1	2 FLM 8X16 F, 2 UGM 8 F	120,17	1
F	SPCKL 86/800 F	800	31,5	1	2 FLM 8X16 F, 2 UGM 8 F	136,62	1
F	SPCKL 86/900 F	900	35,4	1	2 FLM 8X16 F, 2 UGM 8 F	153,05	1
F	SPCKL 86/1000 F	1000	39,4	1	2 FLM 8X16 F, 2 UGM 8 F	169,50	1
F	SPCKL 86/1100 F	1100	43,3	1	2 FLM 8X16 F, 2 UGM 8 F	185,94	1
F	SPCKL 86/1200 F	1200	47,2	1	2 FLM 8X16 F, 2 UGM 8 F	202,39	1

Suitable for: vertical cable ladder STUC 60/...F

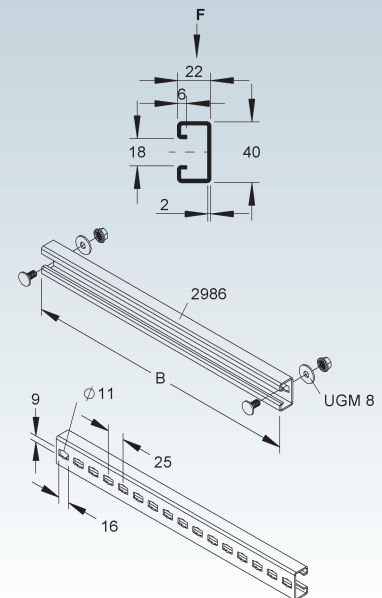

Mounting Clamp for Divider

	Model no.	Acc. incl.	Weight per 100 pcs kg	Pack/Box Qty
F	KLWC 18 F	FK 6X16 E3, GMZ M6 F	4,97	50

for framing channel with a slot width of 18 mm (e.g. STUC 60... and STIC 86...)

Suitable for: divider RW...

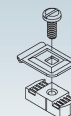

Straight Splice Plate

Model no.	Acc. incl.	Weight per 100 pcs kg	Pack/Box Qty
F VB 6040	4 FLM 10X25 F	61,2	10

Suitable for: profile U 4530/... and U 6040/...
Slotted hole size 11x18 mm, 25 mm pitch.

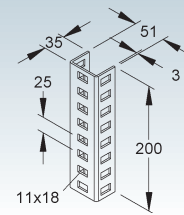

Profile U 6040

Model no.	Length L		Weight per 100 m kg	Pack/Box Qty
	mm	Inch		
F U 6040/3000 F	3000	118,1	338,68	3 m
F U 6040/6000 F	6000	236,2	338,68	6 m

1. Section modulus and moment of inertia are calculated for the perforated section of the profile.

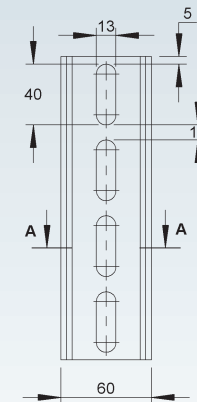
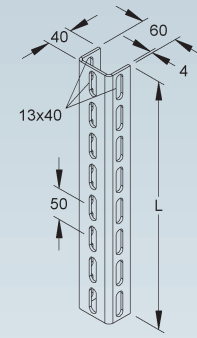

A-A

1.

$$I_y = 6,79 \text{ cm}^4$$

$$I_z = 19,8 \text{ cm}^4$$

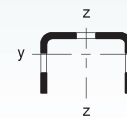

$$W_y = 2,52 \text{ cm}^3$$

$$W_z = 6,62 \text{ cm}^3$$

Protective End Cap

Model no.	Color	Weight per 100 pcs kg	Pack/Box Qty
K03 SKU 6040	yellow	1,32	20

Suitable for: profile U 6040/..., overhead hanger HU 6040/... and vertical cable ladder STUC...



38 39

≈ 27

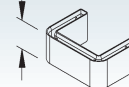

Two Hole Corner Angle

Model no.	Acc. incl.	Weight per 100 pcs kg	Pack/Box Qty
F WWU 150	1 FLM 10X25 F	21,03	50

for floor-, ceiling- or wall-mounting

Suitable for: U-profiles U 4530/..., U 5050/... and U 6040/...

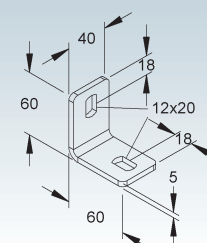

VERTICAL CABLE LADDER SYSTEM

Three Hole Corner Angle

Model no.	Width B mm Inch	Thick-ness t mm	Acc. incl.	Weight per 100 pcs kg	Pack/Box Qty
F WWA 100	50 2	5	1 FLM 10X25 F	24,98	50

for floor-, ceiling- or wall-mounting

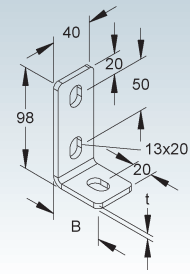

Vertical Cable Ladder

heavy-duty version, delivered as a kit (not assembled)

Model no.	Height H mm Inch	Width B mm Inch	Max. load F kN	Acc. incl.	Weight per 100 m kg	Pack/Box Qty
F STIC 86/206	80 3,1	280 11	1,75	20 FLM 12X30 F	1.388,73	6 m
F STIC 86/306	80 3,1	380 15	1,75	20 FLM 12X30 F	1.417,89	6 m
F STIC 86/406	80 3,1	480 18,9	1,75	20 FLM 12X30 F	1.447,04	6 m
F STIC 86/506	80 3,1	580 22,8	1,75	20 FLM 12X30 F	1.476,19	6 m
F STIC 86/606	80 3,1	680 26,8	1,75	20 FLM 12X30 F	1.505,34	6 m
F STIC 86/706	80 3,1	780 30,7	1	20 FLM 12X30 F	1.534,49	6 m
F STIC 86/806	80 3,1	880 34,6	1	20 FLM 12X30 F	1.563,64	6 m
F STIC 86/906	80 3,1	980 38,6	1	20 FLM 12X30 F	1.592,80	6 m
F STIC 86/1006	80 3,1	1080 42,5	1	20 FLM 12X30 F	1.621,95	6 m
F STIC 86/1106	80 3,1	1180 46,5	1	20 FLM 12X30 F	1.651,10	6 m
F STIC 86/1206	80 3,1	1280 50,4	1	20 FLM 12X30 F	1.680,25	6 m

side rails are made of profile I 80 (DIN 1025 compliant), rungs are made of framing channel 2986...

Standard rung spacing A=600 mm (24 Inch)

1. Section modulus and moment of inertia are calculated for the perforated section of the profile.

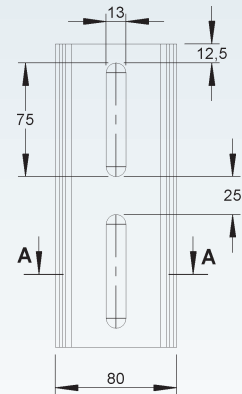
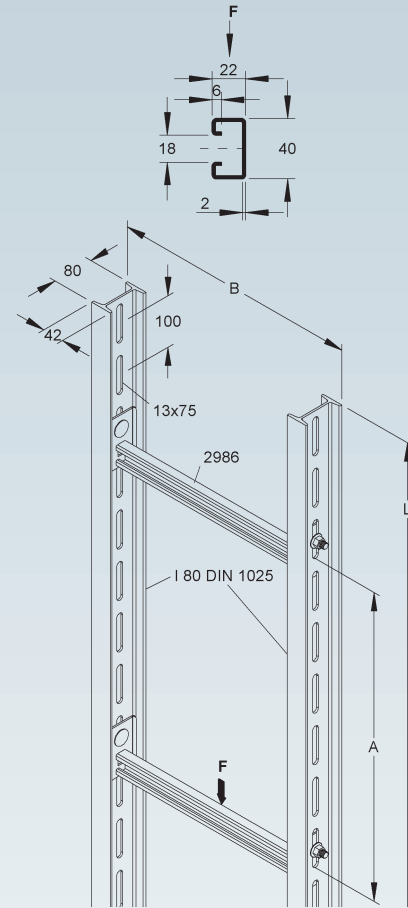

1.

$$\begin{aligned}
 I_y &= 6,27 \text{ cm}^4 & I_z &= 77,63 \text{ cm}^4 & W_y &= 1,49 \text{ cm}^3 & W_z &= 19,4 \text{ cm}^3
 \end{aligned}$$



Rungs for Vertical Cable Ladders

C-rail type 2986 (40x22x2 mm), for additional needs

	Model no.	Width B		Max. load F	Acc. incl.	Weight per 100 pcs kg	Pack/Box Qty
		mm	Inch				
F	SPC 86/200	234	9,2	1,75	2 FLM 12X30 F	87,70	1
F	SPC 86/300	334	13,1	1,75	2 FLM 12X30 F	105,19	1
F	SPC 86/400	434	17,1	1,75	2 FLM 12X30 F	122,68	1
F	SPC 86/500	534	21	1,75	2 FLM 12X30 F	140,17	1
F	SPC 86/600	634	25	1,75	2 FLM 12X30 F	157,66	1
F	SPC 86/700	734	28,9	1	2 FLM 12X30 F	175,15	1
F	SPC 86/800	834	32,8	1	2 FLM 12X30 F	192,64	1
F	SPC 86/900	934	36,8	1	2 FLM 12X30 F	210,13	1
F	SPC 86/1000	1034	40,7	1	2 FLM 12X30 F	227,62	1
F	SPC 86/1100	1134	44,6	1	2 FLM 12X30 F	245,11	1
F	SPC 86/1200	1234	48,6	1	2 FLM 12X30 F	262,60	1

Suitable for: vertical cable ladder STIC 86/...

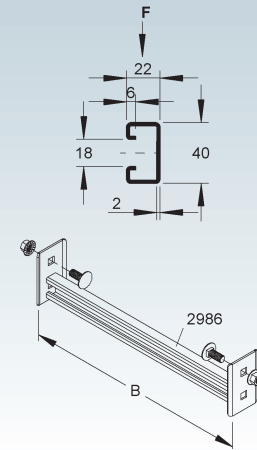

Mounting Clamp for Divider

Model no.	Acc. incl.	Weight per 100 pcs kg	Pack/Box Qty
F KLWC 18 F	FK 6X16 E3, GMZ M6 F	4,97	50

for framing channel with a slot width of 18 mm (e.g. STUC 60... and STIC 86...)

Suitable for: divider RW...

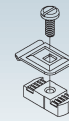

Straight Splice Plate

Model no.	Acc. incl.	Weight per 100 pair kg	Pack/Box Qty
F VBI 80	4 FLM 10X25 F	75,7	5 pair

2 pieces required per joint

Suitable for: profile I 80/... and overhead hanger HI 80/...

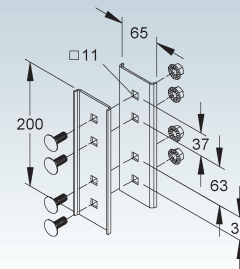

Head Plate

Model no.	Total length L	Thickness of the head plate t	Acc. incl.	Weight per 100 pcs kg	Pack/Box Qty
	mm Inch	mm Inch			
F KI 80	151 5,9	6 0,2	2 FLM 10X25 F	135,9	1

for mounting on horizontal ceilings

Suitable for: profile I 80/...

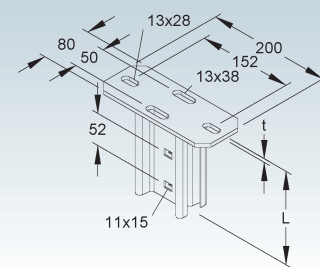

Head Plate

crosswise to profile I 80

Model no.	Total length L	Thickness of the head plate t	Acc. incl.	Weight per 100 pcs kg	Pack/Box Qty
	mm Inch	mm Inch			
F KIQ 80	151 5,9	6 0,2	2 FLM 10X25 F	151,76	1

for mounting on horizontal ceilings

Suitable for: profile I 80/...

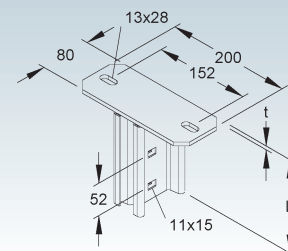

VERTICAL CABLE LADDER SYSTEM

Profile I 80

according to DIN 1025 standard

	Model no.	Length L		Weight per 100 m kg	Pack/Box Qty
		mm	Inch		
F	I 80/3000 FL	3000	118,1	622,8	3 m
F	I 80/6000 FL	6000	236,2	622,8	6 m

for building customized overhead hangers, floorstands or support frames

1. Section modulus and moment of inertia are calculated for the perforated section of the profile.

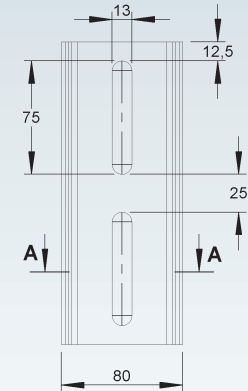
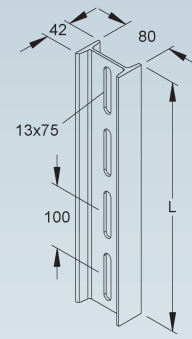

A-A

1.

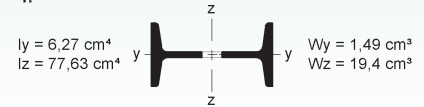

Protective End Cap

Model no.	Color	Weight per 100 pcs kg	Pack/Box Qty	
K03	SKI 80	yellow	1,54	20

Suitable for: profile I 80/... as well as overhead hanger HI 80/...



38 39

≈ 27

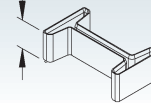

Two Hole Corner Angle for I 80

equal-sided

Model no.	Acc. incl.	Weight per 100 pcs kg	Pack/Box Qty	
F	WWI 80	1 FLM 12X30 F	22,69	50

for wall-mounting of profile I 80/...

Suitable for: profile I 80/..., overhead hangers HI 80/... and vertical cable ladders of STIC.... and STIW...

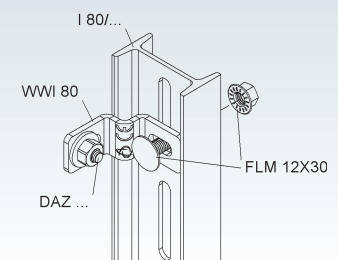
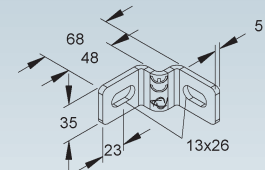

Enclosure Panel Kit for Vertical Ladder

	Model no.	Height H		Width B		Length L		Acc. incl.	Weight per 100 m kg	Pack/ Box Qty
		mm	Inch	mm	Inch	mm	Inch			
S	STVWA 200 S	203	8	309	12,2	3000	118,1	6 STVDP 30.43 S	877,11	3 m
S	STVWA 300 S	203	8	409	16,1	3000	118,1	6 STVDP 30.43 S	1.034,11	3 m
S	STVWA 400 S	203	8	509	20	3000	118,1	6 STVDP 30.43 S	1.191,11	3 m
S	STVWA 500 S	203	8	609	24	3000	118,1	6 STVDP 30.43 S	1.348,11	3 m
S	STVWA 600 S	203	8	709	27,9	3000	118,1	6 STVDP 30.43 S	1.505,11	3 m
F	STVWA 200 F	203	8	309	12,2	3000	118,1	6 STVDP 30.43 F	964,82	3 m
F	STVWA 300 F	203	8	409	16,1	3000	118,1	6 STVDP 30.43 F	1.137,52	3 m
F	STVWA 400 F	203	8	509	20	3000	118,1	6 STVDP 30.43 F	1.310,22	3 m
F	STVWA 500 F	203	8	609	24	3000	118,1	6 STVDP 30.43 F	1.482,92	3 m
F	STVWA 600 F	203	8	709	27,9	3000	118,1	6 STVDP 30.43 F	1.655,62	3 m

Suitable for: vertical cable ladders STUC 60/... and STIC 86/... only
 Kit contains 2 sidepanels, 6 brackets, 1 cover and 6 clamps.

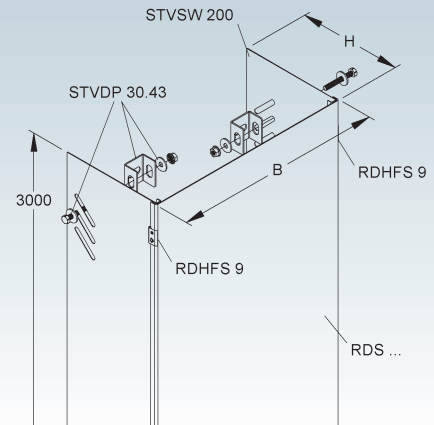

Enclosure Panel Kit for Vertical Ladder

	Model no.	Height H		Width B		Length L		Acc. incl.	Weight per 100 m kg	Pack/ Box Qty
		mm	Inch	mm	Inch	mm	Inch			
S	STVFA 200 S	236	9,3	309	12,2	3000	118,1	6 STVDP 30.43 S	1.468,23	3 m
S	STVFA 300 S	236	9,3	409	16,1	3000	118,1	6 STVDP 30.43 S	1.782,23	3 m
S	STVFA 400 S	236	9,3	509	20	3000	118,1	6 STVDP 30.43 S	2.096,23	3 m
S	STVFA 500 S	236	9,3	609	24	3000	118,1	6 STVDP 30.43 S	2.410,23	3 m
S	STVFA 600 S	236	9,3	709	27,9	3000	118,1	6 STVDP 30.43 S	2.724,23	3 m
F	STVFA 200 F	236	9,3	309	12,2	3000	118,1	6 STVDP 30.43 F	1.615,05	3 m
F	STVFA 300 F	236	9,3	409	16,1	3000	118,1	6 STVDP 30.43 F	1.960,45	3 m
F	STVFA 400 F	236	9,3	509	20	3000	118,1	6 STVDP 30.43 F	2.305,85	3 m
F	STVFA 500 F	236	9,3	609	24	3000	118,1	6 STVDP 30.43 F	2.651,25	3 m
F	STVFA 600 F	236	9,3	709	27,9	3000	118,1	6 STVDP 30.43 F	2.996,65	3 m

Suitable for: vertical cable ladders STUC 60/... and STIC 86/... only
 Kit contains 2 sidepanels, 6 brackets, 2 covers and 12 clamps.

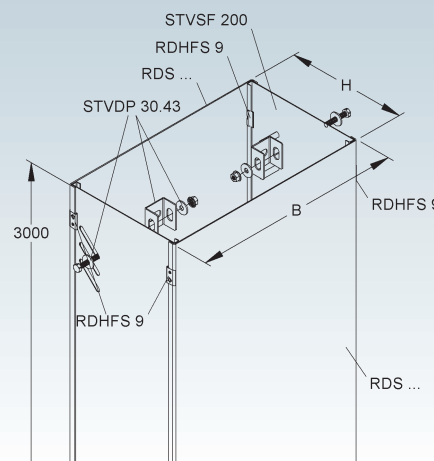

Mounting Kit for Enclosure Panel

	Model no.	Weight per 100 pcs kg	Pack/ Box Qty
S	STVDP 30.43 S	10,70	6
F	STVDP 30.43 F	11,32	6

Suitable for: enclosure panel kit for vertical ladders STVWA... and STVFA... only

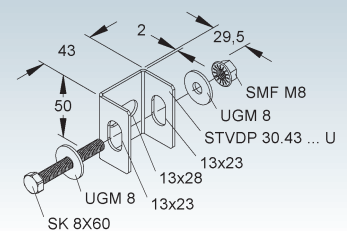

VERTICAL CABLE LADDER SYSTEM

Heavy Duty Cover Clamp

Model no.	Weight per 100 pcs kg	Pack/Box Qty
VZL RDHFS 9 VZL	1,07	60

Suitable for: all heavy duty covers in S and F finish for cable trays and fittings as well as for vertical ladder enclosure panels

Please maintain a 50 mm minimum distance from the edge of the cover for the cover clamp installation.

Not sufficient for securing covers against windloads. Please use self tapping screws, steel cable ties or coverhinges in addition.

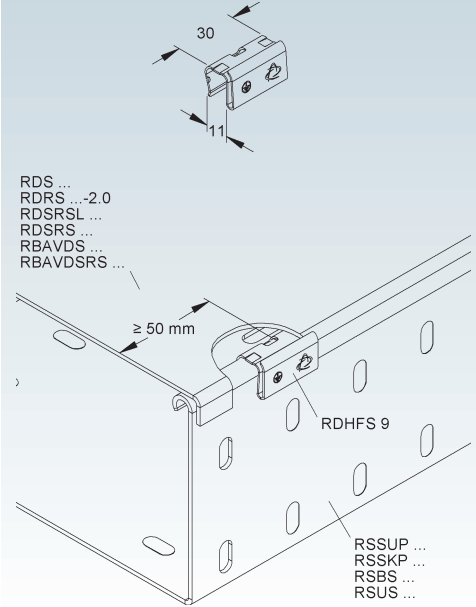

NOTES

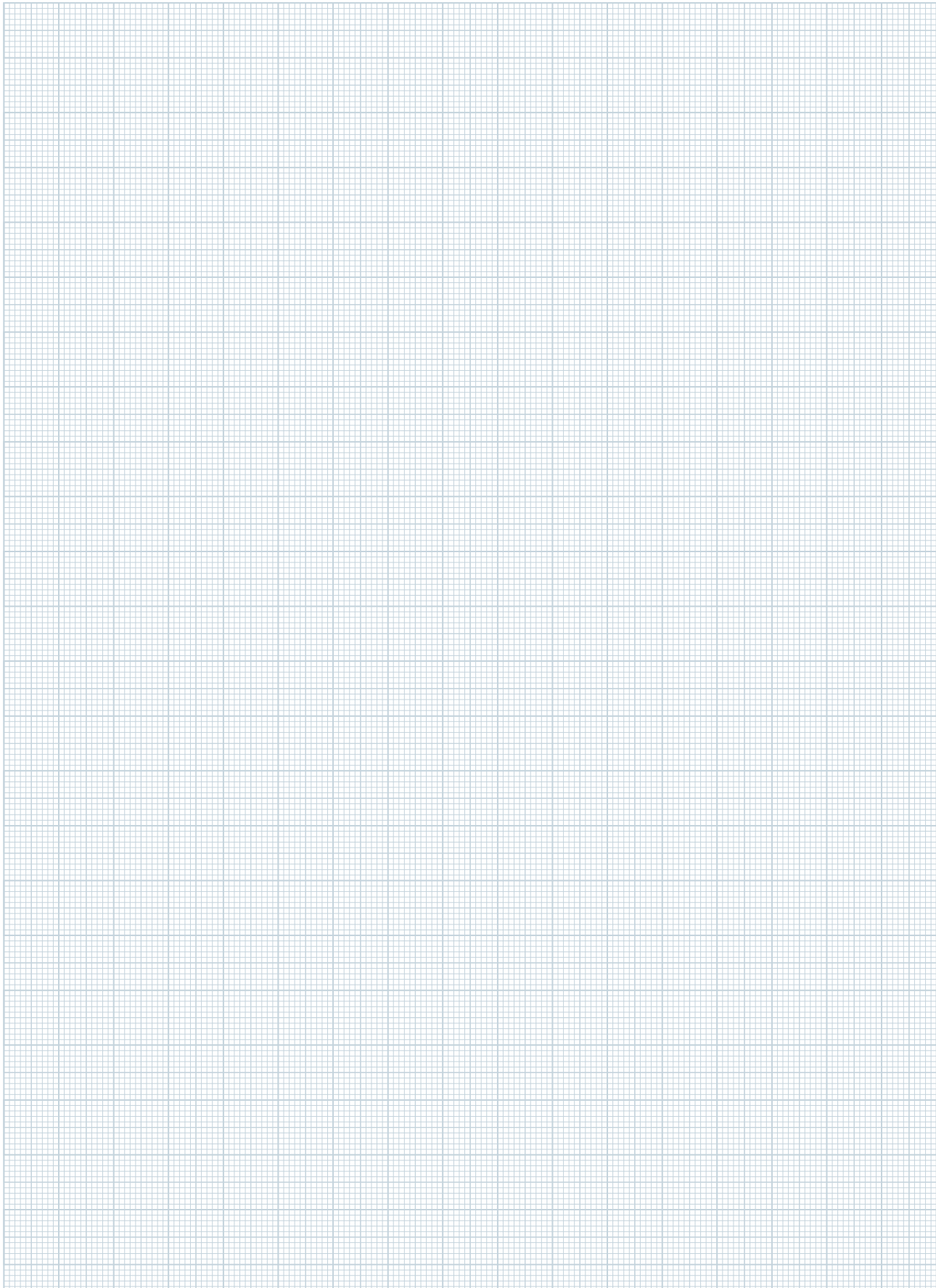

CABLE TRAY SYSTEM

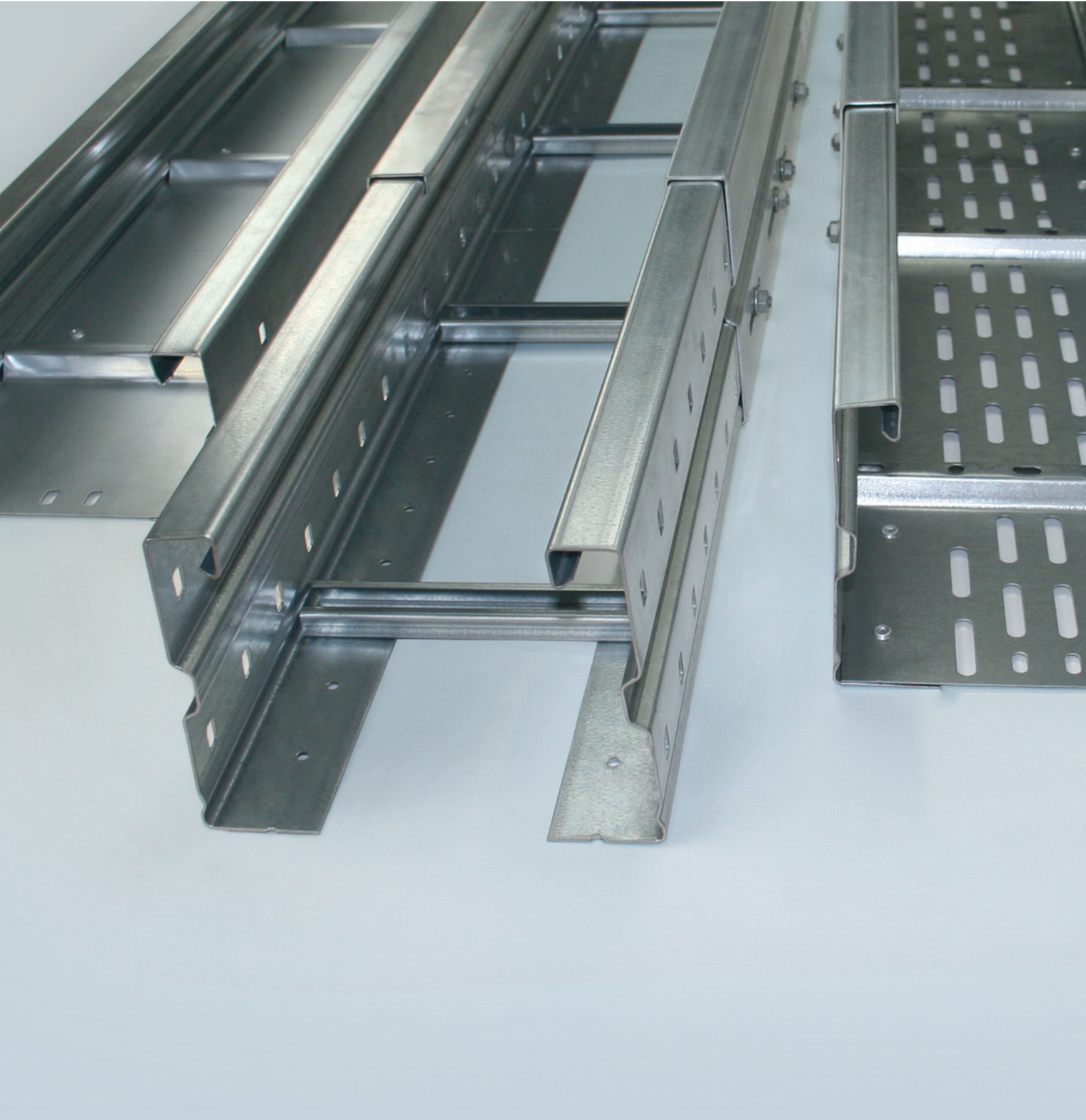

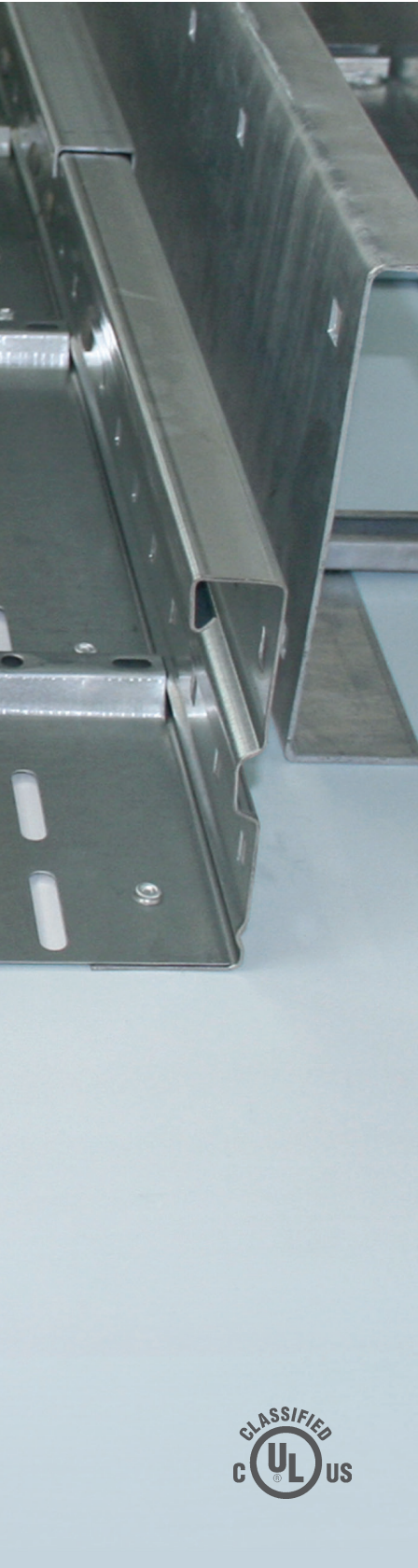

LONG SPAN SYSTEM

- Long Span Cable Tray
- Fittings
- Long Span Cable Ladder
- Accessories

The Long Span System is used where long support spans and high cable load capacities are required. Our heavy duty versions show a load rating of 20C according to NEMA. The main application for Long Span Cable Ladders are heavy duty power cables, while Long Span Trays allow a combination of control- and power cables. Like with all Niedax cable management systems you can select from a wide range of sizes, fittings and accessories in various material thicknesses and finishes.

! Long support spans are causing high load ratings to each individual support. Load capacities shown are valid only for proper anchorage to the building structure. Please consult structural engineering for maximum allowable ratings and special local regulations.

All straight sections of cable tray as well as their corresponding system components (fittings, splice plates, covers, ...) are classified by UL in accordance with NEMA VE 1 for the USA and CSA C22.1 No. 126.1 for Canada.

An 'X' in the part number will be added for labeling according to UL instructions (see catalog page 40).



LONG SPAN CABLE TRAY

Available Side Rail Heights



SYSTEM			↑105 mm	Nominal 4 inches	↑150 mm	Nominal 6 inches
	Long Span Cable Tray	WRL...	↑105	Page 290	↑150	Page 295
	Long Span Cable Tray	WRU...	↑105	Page 290	↑150	Page 295
	Long Span Cable Tray	WRLM...	↑105	—	↑150	Page 296
ACCESSORIES	Splice Plate	WSV...	↑105	Page 291	↑150	Page 296
	Adjustable Splice Plate	WSGV...	↑105	Page 291	↑150	Page 296
	Adjustable Splice Plate	WSWV...	↑105	Page 291	↑150	Page 297
	Divider	RW...		Page 291/297		
	Splice Plate for Divider	RTV...		Page 291/297		
	Mounting Clamp for Divider	KLWC 16...		Page 292/297		
	Extension Horizontal Tee	WRTAR...	↑105	Page 292	↑150	Page 298
	Horizontal Elbow Building Block	WAER...	↑105	Page 292	↑150	Page 298
	Horizontal Elbow 90°	WRBR...	↑105	Page 293	↑150	Page 298
	Horizontal Tee	WRTR...	↑105	Page 293	↑150	Page 299
	Reducer	WSRS...	↑105	Page 293	↑150	Page 299
	Endplate	WSAS...	↑105	Page 293	↑150	Page 299
	Wall/Floor and Cross Connector Bracket	WHAS...	↑105	Page 294	↑150	Page 300
	Pair of Protective End Caps	SKWHM...	↑105	Page 294	↑150	Page 300
	Bottom Connection Plate	RSL...		Page 300		
	Edge Protection Plate	RKB...		Page 301		
	Edge Protection	WBKS 130 E3		Page 301		

Support Span L m	WRL 105...		WRL 150...		WRLM 150...	
	q kN/m	F kN	q kN/m	F kN	q kN/m	F kN
3	3,00	9,30	3,15	9,80	3,45	10,75
4	1,70	7,20	2,40	10,05	2,90	12,15
5	1,10	6,00	1,75	9,30	2,35	12,40
6	0,75	5,10	1,20	7,85	1,85	11,90
7	0,55	4,55	0,85	6,75	1,35	10,40
8	0,40	4,00	0,60	5,70	1,00	9,05
9	0,31	3,70	0,43	4,85	0,77	8,10
10	-	-	-	-	-	-
11	-	-	-	-	-	-
12	-	-	-	-	-	-

q = Uniformly distributed load F = Force



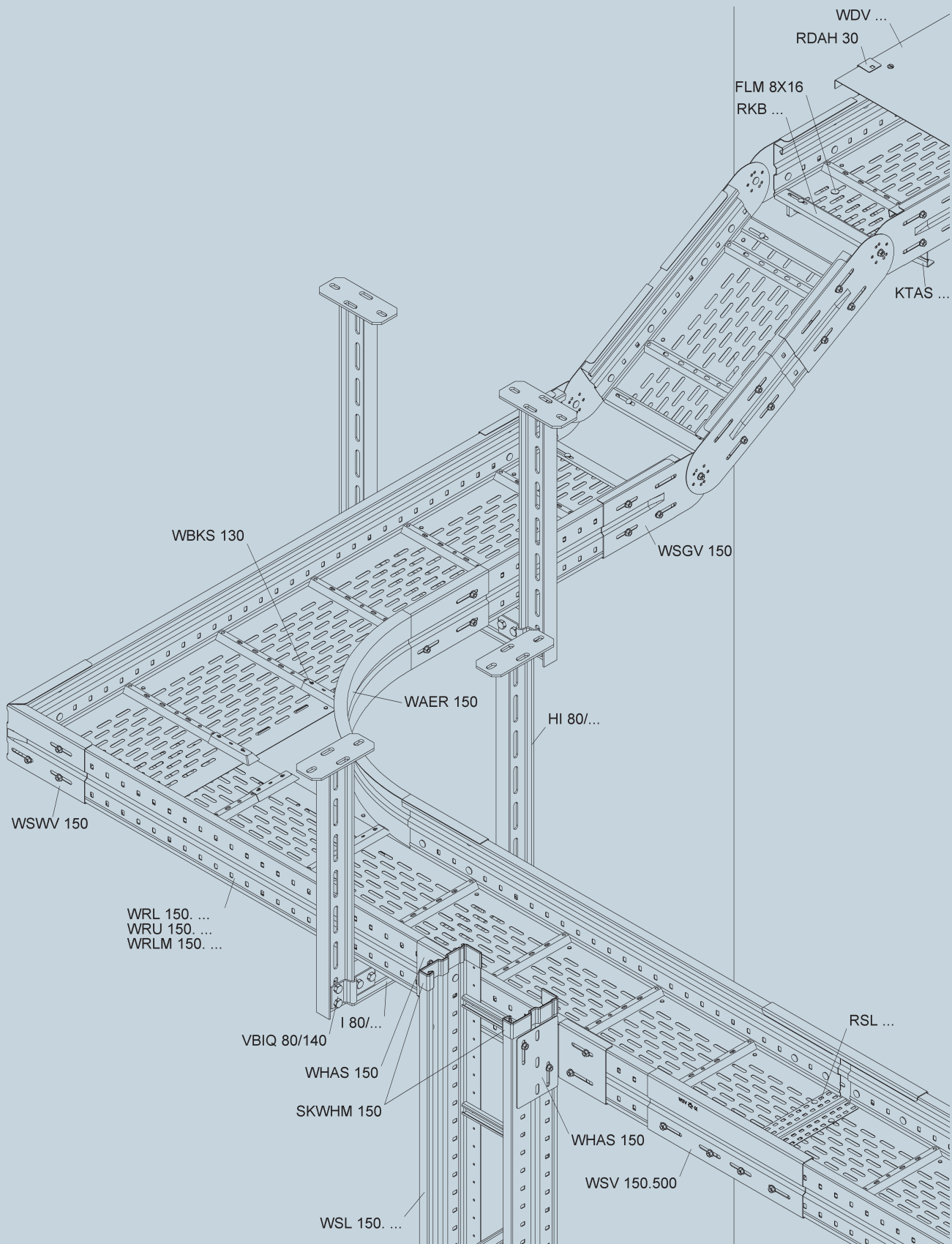

LONG SPAN CABLE TRAY

Long Span Cable Tray and Cable Ladder Specifications:

A. CABLE TRAY DESIGN

1. Cable Tray shall be made of straight sections, fittings and accessories as defined in the latest NEMA standards per NEMA VE-1. Standard cable trays shall be UL classified as equipment grounding conductors.

B. MATERIAL

1. **Pre-galvanized steel.** The structural quality of the steel shall meet the minimum yield and tensile strength of the ASTM standards (ASTM A 653) with G 90 coating thickness. All cable trays to be labeled for material identification purposes.
2. **Hot dipped galvanized steel.** All trays to be hot-dipped galvanized in accordance with ASTM A123. All trays to be labeled for material identification.
3. **Stainless steel.** All trays are to be constructed of AISI type 304 or 316 stainless steel. All trays to be labeled for material identification.

C. TRAY TYPES

1. **Ventilated cable tray.** Ventilated trough shall incorporate two side-rails connected by corrugated ventilated metal.
2. **Solid cable tray.** Solid bottom tray shall incorporate two side rails connected by solid steel metal.
3. **Ladder cable tray.** Ladder shall consist of two side-rails with rungs riveted to the bottom flange of the side-rails. Rungs shall be spaced 8" or 12" (200 or 300 mm) on center. Rungs shall not protrude below the bottom of the side-rail.

D. TRAY SIZE

1. **Height:** Trays shall have an overall height of 4", 6", and 8" (105, 150 and 200 mm). Minimum load depth shall be 3.5", 5.5" and 7.5" (90, 135 and 185 mm).
2. **Width:** Widths shall be 8", 12", 16", 20" and 24" (200, 300, 400, 500 and 600 mm).
3. **Length:** Length shall be a nominal 10' or 3 meters, and 20' or 6 meters

E. ACCESSORIES

1. **Covers.** Covers shall be supplied to protect tray cable where needed. Covers will be solid and contain three pair of turn-bolt locks to secure the covers to the lips of the cable tray, requiring only the use of a slotted screwdriver.
2. **Splice plates.** Splice plates shall fasten to the outside of the cable tray side-rails and wrap around and snap onto each section of tray. Bolts and nuts are used to fasten to the tray and are included with splice plates. Plates shall not exceed the NEMA VE-1 resistance of 330 micro ohms.
3. **Other accessories** shall be furnished as required to protect, support, and install a cable tray system. Fittings shall made of the same material as the cable tray whenever possible. Fittings can be of factory construction or also be of a type that allows field constructed fittings.

F. LOADING CAPABILITIES

1. Cable tray shall meet the load/span class designation in accordance with NEMA VE 1 and CSA E22.2 No 126.1. Cable tray shall also meet load/span designation in accordance with IEC 61537.

G. DESIGN AND MANUFACTURE

1. Cable tray design shall be manufactured by The Niedax Group.

Load/Span Class Designation in accordance with NEMA VE 1 and CSA C22.2 No. 126.1

Niedax Series	Minimum Area		Load class in accordance to NEMA VE 1		
	(calculational) mm ² / in. ²	in accordance to NEMA VE 2 mm ² / in. ²	Rated Load Kg/m / lb./ft.	Support spacing m / ft.	Load/Span Class
WRLX 105.200, ... F, ... E3	627.0 / 0.97	452 / 0.7	80 / 53.8	6 / 19.7	12C, D, 20A
WRLX 105.300, ... F, ... E3	627.0 / 0.97	452 / 0.7	80 / 53.8	6 / 19.7	12C, D, 20A
WRLX 105.400, ... F, ... E3	627.0 / 0.97	452 / 0.7	80 / 53.8	6 / 19.7	12C, D, 20A
WRLX 105.500, ... F, ... E3	627.0 / 0.97	452 / 0.7	80 / 53.8	6 / 19.7	12C, D, 20A
WRLX 105.600, ... F, ... E3	627.0 / 0.97	452 / 0.7	80 / 53.8	6 / 19.7	12C, D, 20A
WRUX 105.200, ... F	627.0 / 0.97	452 / 0.7	80 / 53.8	6 / 19.7	12C, D, 20A
WRUX 105.300, ... F	627.0 / 0.97	452 / 0.7	80 / 53.8	6 / 19.7	12C, D, 20A
WRUX 105.400, ... F	627.0 / 0.97	452 / 0.7	80 / 53.8	6 / 19.7	12C, D, 20A
WRUX 105.500, ... F	627.0 / 0.97	452 / 0.7	80 / 53.8	6 / 19.7	12C, D, 20A
WRUX 105.600, ... F	627.0 / 0.97	452 / 0.7	80 / 53.8	6 / 19.7	12C, D, 20A
WRLX 150.200, ... F, ... E3	762.0 / 1.18	645 / 1.0	80 / 53.8	6 / 19.7	12C, D, 20A
WRLX 150.300, ... F, ... E3	762.0 / 1.18	645 / 1.0	80 / 53.8	6 / 19.7	12C, D, 20A
WRLX 150.400, ... F, ... E3	762.0 / 1.18	645 / 1.0	80 / 53.8	6 / 19.7	12C, D, 20A
WRLX 150.500, ... F, ... E3	762.0 / 1.18	645 / 1.0	80 / 53.8	6 / 19.7	12C, D, 20A
WRLX 150.600, ... F, ... E3	762.0 / 1.18	645 / 1.0	80 / 53.8	6 / 19.7	12C, D, 20A
WRUX 150.200, ... F	762.0 / 1.18	645 / 1.0	80 / 53.8	6 / 19.7	12C, D, 20A
WRUX 150.300, ... F	762.0 / 1.18	645 / 1.0	80 / 53.8	6 / 19.7	12C, D, 20A
WRUX 150.400, ... F	762.0 / 1.18	645 / 1.0	80 / 53.8	6 / 19.7	12C, D, 20A
WRUX 150.500, ... F	762.0 / 1.18	645 / 1.0	80 / 53.8	6 / 19.7	12C, D, 20A
WRUX 150.600, ... F	762.0 / 1.18	645 / 1.0	80 / 53.8	6 / 19.7	12C, D, 20A
WRLMX 150.200, ... F	896 / 1.39	645 / 1.0	122 / 82	6 / 19.7	12C, E, 20B
WRLMX 150.300, ... F	896 / 1.39	645 / 1.0	122 / 82	6 / 19.7	12C, E, 20B
WRLMX 150.400, ... F	896 / 1.39	645 / 1.0	122 / 82	6 / 19.7	12C, E, 20B
WRLMX 150.500, ... F	896 / 1.39	645 / 1.0	122 / 82	6 / 19.7	12C, E, 20B
WRLMX 150.600, ... F	896 / 1.39	645 / 1.0	122 / 82	6 / 19.7	12C, E, 20B



LONG SPAN CABLE TRAY

Long Span Cable Tray

ventilated bottom

	Model no.	Height H		Width B		Length L		Thick-ness t	Weight per 100 m	Pack/Box Qty
		mm	Inch	mm	Inch	mm	Inch			
S	WRL 105.200	105	4,1	200	7,9	6000	236,2	1,5	623,63	6 m
S	WRL 105.300	105	4,1	300	11,8	6000	236,2	1,5	684,14	6 m
S	WRL 105.400	105	4,1	400	15,7	6000	236,2	1,5	749,95	6 m
S	WRL 105.500	105	4,1	500	19,7	6000	236,2	1,5	811,83	6 m
S	WRL 105.600	105	4,1	600	23,6	6000	236,2	1,5	887,55	6 m
F	WRL 105.200 F	105	4,1	200	7,9	6000	236,2	1,5	686,77	6 m
F	WRL 105.300 F	105	4,1	300	11,8	6000	236,2	1,5	753,33	6 m
F	WRL 105.400 F	105	4,1	400	15,7	6000	236,2	1,5	825,75	6 m
F	WRL 105.500 F	105	4,1	500	19,7	6000	236,2	1,5	893,82	6 m
F	WRL 105.600 F	105	4,1	600	23,6	6000	236,2	1,5	977,02	6 m
E3	WRL 105.200 E3	105	4,1	200	7,9	6000	236,2	1,5	628,19	6 m
E3	WRL 105.300 E3	105	4,1	300	11,8	6000	236,2	1,5	689,09	6 m
E3	WRL 105.400 E3	105	4,1	400	15,7	6000	236,2	1,5	754,87	6 m
E3	WRL 105.500 E3	105	4,1	500	19,7	6000	236,2	1,5	817,02	6 m
E3	WRL 105.600 E3	105	4,1	600	23,6	6000	236,2	1,5	893,19	6 m

Transversal reinforcing fins in the ventilated bottom plate are providing extra stability and an easy way to attach dividers.

Also available in 3-meter length.

A bottom connection plate will be supplied for tray in 400, 500 and 600 mm width.

Load Chart: q = uniformly distributed load (tested according to DIN EN IEC 61537 standard)

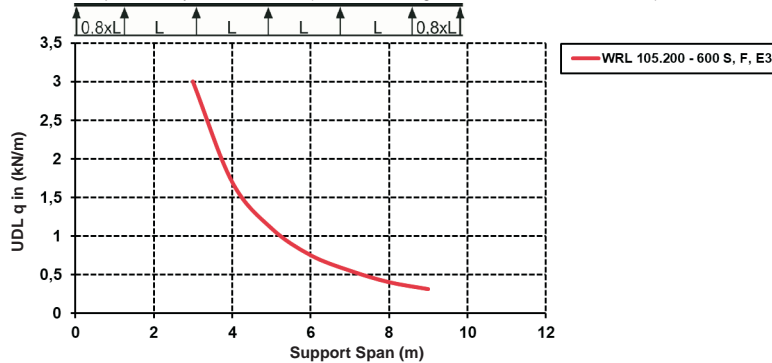

Specified load ratings are independent of splice plate location.

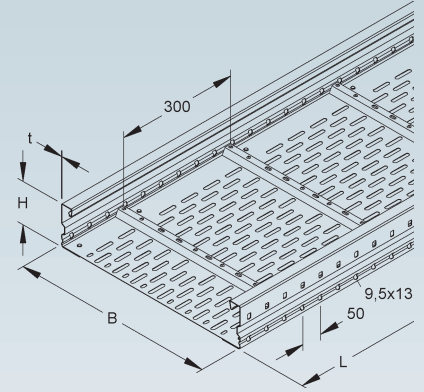
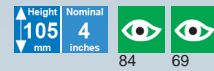

Long Span Cable Tray

solid, but with splice plate perforation

	Model no.	Height H		Width B		Length L		Thick-ness t	Weight per 100 m	Pack/Box Qty
		mm	Inch	mm	Inch	mm	Inch			
S	WRU 105.200	105	4,1	200	7,9	6000	236,2	1,5	649,98	6 m
S	WRU 105.300	105	4,1	300	11,8	6000	236,2	1,5	724,86	6 m
S	WRU 105.400	105	4,1	400	15,7	6000	236,2	1,5	804,83	6 m
S	WRU 105.500	105	4,1	500	19,7	6000	236,2	1,5	880,87	6 m
S	WRU 105.600	105	4,1	600	23,6	6000	236,2	1,5	956,83	6 m
F	WRU 105.200 F	105	4,1	200	7,9	6000	236,2	1,5	715,75	6 m
F	WRU 105.300 F	105	4,1	300	11,8	6000	236,2	1,5	798,12	6 m
F	WRU 105.400 F	105	4,1	400	15,7	6000	236,2	1,5	886,12	6 m
F	WRU 105.500 F	105	4,1	500	19,7	6000	236,2	1,5	969,76	6 m
F	WRU 105.600 F	105	4,1	600	23,6	6000	236,2	1,5	1.053,23	6 m

Transversal reinforcing fins in the solid bottom plate are providing extra stability and an easy way to attach dividers.

Also available in 3-meter length.

A bottom connection plate will be supplied for tray in 400, 500 and 600 mm width.

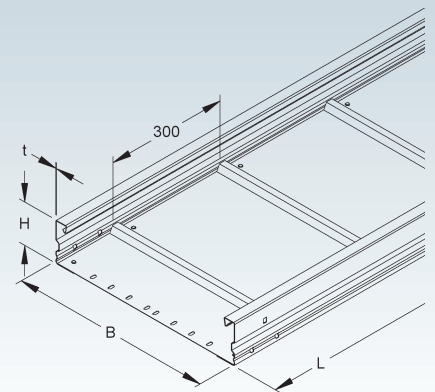
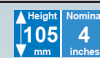

Splice Plate

Model no.	Inside height H mm Inch	Width B mm Inch	Acc. incl.	Weight per 100 pcs kg	Pack/Box Qty
S WSV 105.390	106,5 4,2	390 15,4	4 FLM 8X13 F	116,04	10
F WSV 105.390 F	106,5 4,2	390 15,4	4 FLM 8X13 F	126,88	10
E3 WSV 105.390 E3	106,5 4,2	390 15,4	4 FLM 8X16 E3	117,05	10

form-locking straight splice plate for long span trays and ladders

2 pieces required per joint

UL classified splice plates ensure electrical continuity and proper bonding.

Height
105 mm
Nominal
4 inches

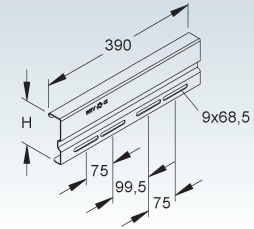

Adjustable Splice Plate

vertical

Model no.	Inside height H mm Inch	Acc. incl.	Weight per 100 pcs kg	Pack/Box Qty
S WSGV 105	106,5 4,2	6 FLM 8X13 F	91,97	1
F WSGV 105 F	106,5 4,2	6 FLM 8X13 F	99,97	1
E3 WSGV 105 E3	106,5 4,2	6 FLM 8X16 E3	92,46	1

2 pieces required per joint

UL classified splice plates ensure electrical continuity and proper bonding.

Height
105 mm
Nominal
4 inches

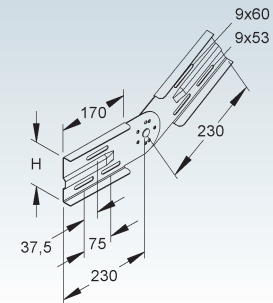

Adjustable Splice Plate

horizontal

Model no.	Inside height H mm Inch	Width B mm Inch	Acc. incl.	Weight per 100 pcs kg	Pack/Box Qty
S WSWV 105.390	106,5 4,2	390 15,4	6 FLM 8X13 F	92,46	10
F WSWV 105.390 F	106,5 4,2	390 15,4	6 FLM 8X13 F	100,57	10
E3 WSWV 105.390 E3	106,5 4,2	390 15,4	6 FLM 8X16 E3	82,33	10

2 pieces required per joint

UL classified splice plates ensure electrical continuity and proper bonding.

Height
105 mm
Nominal
4 inches

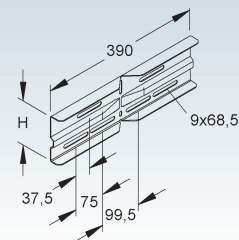

Divider

Model no.	Height H mm Inch	Thickness t mm	Acc. incl.	Weight per 100 m kg	Pack/Box Qty
S RW 85	80 3,1	0,9	4 FLM 6X12	77,65	10 x 3 m
F RW 85 F	80 3,1	0,9	4 FLM 6X12 F	85,30	10 x 3 m
E3 RW 85 E3	80 3,1	0,9	4 FLM 6X12 E3	78,17	10 x 3 m

to separate wires and cables of different voltage levels or with different functions

Height
85 mm
Nominal
3 3/8 inches



69

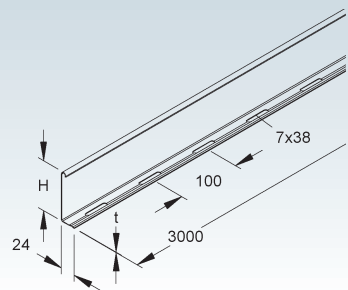

Splice Plate for Divider

Model no.	Height H mm Inch	Length L mm Inch	Weight per 100 pcs kg	Pack/Box Qty
E2 RTV 85 E2	79,5 3,1	80 3,1	2,03	20

for positive locking connections and proper bonding of dividers

Height
85 mm
Nominal
3 3/8 inches



69

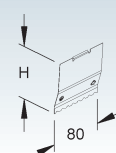

LONG SPAN CABLE TRAY

Mounting Clamp for Divider

Model no.	Acc. incl.	Weight per 100 pcs kg	Pack/Box Qty
S KLWC 16	1 FK 6X12 V, GSM 406 G	2,64	50
F KLWC 16 F	1 FK 6X10 E3, GSM 406 E3	2,70	50

Suitable for: divider RW...

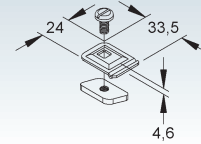

Mounting Clamp for Divider

Model no.	Acc. incl.	Weight per 100 pcs kg	Pack/Box Qty
E3 KLWC 16 E3	1 FK 6X10 E3, GSM 406 E3	3	50

Suitable for: divider RW...

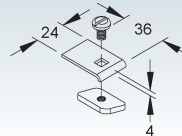

Extension Horizontal Tee

with integrated splices

Model no.	Inside height H mm Inch	Inside dimension B mm Inch	Acc. incl.	Weight per 100 pcs kg	Pack/Box Qty
S WRTAR 105.200	106,5 4,2	205 8,1	12 FLM 8X13 F	1.143,65	1
S WRTAR 105.300	106,5 4,2	305 12	12 FLM 8X13 F	1.212,23	1
S WRTAR 105.400	106,5 4,2	405 15,9	12 FLM 8X13 F	1.280,81	1
S WRTAR 105.500	106,5 4,2	505 19,9	12 FLM 8X13 F	1.349,39	1
S WRTAR 105.600	106,5 4,2	605 23,8	12 FLM 8X13 F	1.417,97	1
F WRTAR 105.200 F	106,5 4,2	205 8,1	12 FLM 8X13 F	1.255,41	1
F WRTAR 105.300 F	106,5 4,2	305 12	12 FLM 8X13 F	1.330,84	1
F WRTAR 105.400 F	106,5 4,2	405 15,9	12 FLM 8X13 F	1.406,28	1
F WRTAR 105.500 F	106,5 4,2	505 19,9	12 FLM 8X13 F	1.481,72	1
F WRTAR 105.600 F	106,5 4,2	605 23,8	12 FLM 8X13 F	1.557,16	1
E3 WRTAR 105.200 E3	106,5 4,2	205 8,1	12 FLM 8X16 E3	990,63	1
E3 WRTAR 105.300 E3	106,5 4,2	305 12	12 FLM 8X16 E3	1.054,21	1
E3 WRTAR 105.400 E3	106,5 4,2	405 15,9	12 FLM 8X16 E3	1.117,79	1
E3 WRTAR 105.500 E3	106,5 4,2	505 19,9	12 FLM 8X16 E3	1.275,52	1
E3 WRTAR 105.600 E3	106,5 4,2	605 23,8	12 FLM 8X16 E3	1.344,53	1

for field manufacturing of horizontal tees and crosses

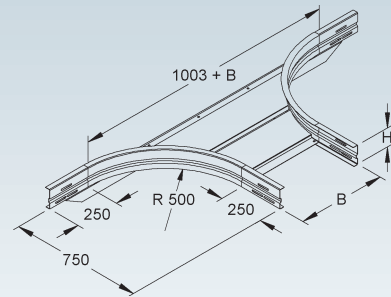
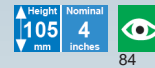

Horizontal Elbow Building Block

with integrated splices

Model no.	Inside height H mm Inch	Acc. incl.	Weight per 100 pcs kg	Pack/Box Qty
S WAER 105	106,5 4,2	10 FLM 8X13 F	413,30	1
F WAER 105 F	106,5 4,2	10 FLM 8X13 F	452,63	1
E3 WAER 105 E3	106,5 4,2	10 FLM 8X16 E3	374,73	1

for field manufacturing of longspan elbows and tees

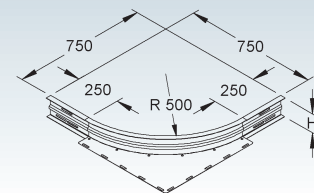

Horizontal Elbow 90°

with solid siderails but prepunched holes for splice plates

	Model no.	Height H		Width B		Weight per 100 pcs kg	Pack/Box Qty
		mm	Inch	mm	Inch		
S	WRBR 105.200	105	4,1	200	7,9	961,38	1
S	WRBR 105.300	105	4,1	300	11,8	1.139,76	1
S	WRBR 105.400	105	4,1	400	15,7	1.330,63	1
S	WRBR 105.500	105	4,1	500	19,7	1.534,20	1
S	WRBR 105.600	105	4,1	600	23,6	1.749,74	1
F	WRBR 105.200 F	105	4,1	200	7,9	1.057,52	1
F	WRBR 105.300 F	105	4,1	300	11,8	1.253,74	1
F	WRBR 105.400 F	105	4,1	400	15,7	1.463,69	1
F	WRBR 105.500 F	105	4,1	500	19,7	1.687,62	1
F	WRBR 105.600 F	105	4,1	600	23,6	1.924,71	1
E3	WRBR 105.200 E3	105	4,1	200	7,9	968,57	1
E3	WRBR 105.300 E3	105	4,1	300	11,8	1.148,25	1
E3	WRBR 105.400 E3	105	4,1	400	15,7	1.340,34	1
E3	WRBR 105.500 E3	105	4,1	500	19,7	1.545,43	1
E3	WRBR 105.600 E3	105	4,1	600	23,6	1.762,33	1

Height 105 mm
Nominal 4 inches

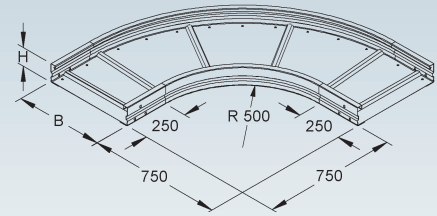

Horizontal Tee

with solid siderails but prepunched holes for splice plates

	Model no.	Height H		Width B		Weight per 100 pcs kg	Pack/Box Qty
		mm	Inch	mm	Inch		
S	WRTR 105.200	105	4,1	200	7,9	1.598,65	1
S	WRTR 105.300	105	4,1	300	11,8	1.841,16	1
S	WRTR 105.400	105	4,1	400	15,7	2.098,05	1
S	WRTR 105.500	105	4,1	500	19,7	2.374,62	1
S	WRTR 105.600	105	4,1	600	23,6	2.660,61	1
F	WRTR 105.200 F	105	4,1	200	7,9	1.758,52	1
F	WRTR 105.300 F	105	4,1	300	11,8	2.025,28	1
F	WRTR 105.400 F	105	4,1	400	15,7	2.307,86	1
F	WRTR 105.500 F	105	4,1	500	19,7	2.612,12	1
F	WRTR 105.600 F	105	4,1	600	23,6	2.926,67	1
E3	WRTR 105.200 E3	105	4,1	200	7,9	1.605,40	1
E3	WRTR 105.300 E3	105	4,1	300	11,8	1.846,89	1
E3	WRTR 105.400 E3	105	4,1	400	15,7	2.102,99	1
E3	WRTR 105.500 E3	105	4,1	500	19,7	2.378,76	1
E3	WRTR 105.600 E3	105	4,1	600	23,6	2.694,43	1

Height 105 mm
Nominal 4 inches

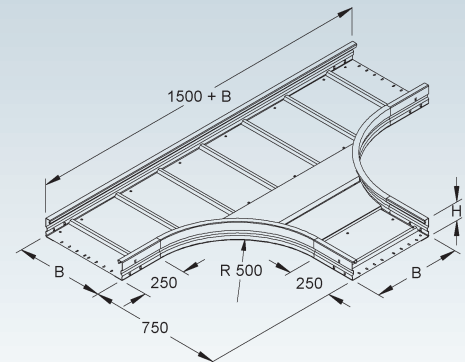

Reducer

	Model no.	Height H		Width B		Weight per 100 pcs kg	Pack/Box Qty
		mm	Inch	mm	Inch		
S	WSRS 105.100 S	105	4,1	100	3,9	32,70	1
S	WSRS 105.150 S	105	4,1	150	5,9	37,53	1
S	WSRS 105.200 S	105	4,1	200	7,9	42,23	1
S	WSRS 105.300 S	105	4,1	300	11,8	52,01	1

can be used as a reducer for long span cable trays and ladders

Height 105 mm
Nominal 4 inches

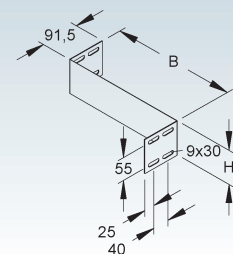

Endplate

	Model no.	Height H		Width B		Weight per 100 pcs kg	Pack/Box Qty
		mm	Inch	mm	Inch		
S	WSAS 105.200 S	102	4	200	7,9	51,63	1
S	WSAS 105.300 S	102	4	300	11,8	63,64	1
S	WSAS 105.400 S	102	4	400	15,7	75,65	1
S	WSAS 105.500 S	102	4	500	19,7	87,66	1
S	WSAS 105.600 S	102	4	600	23,6	99,67	1

can be used as blind end or as reducer for long span cable trays and ladders

Height 105 mm
Nominal 4 inches

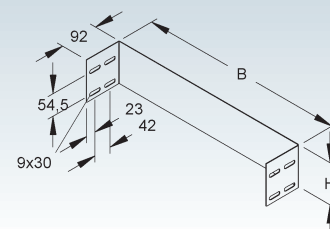

LONG SPAN CABLE TRAY

Wall/Floor and Cross Connector Bracket

for Long Span Ladder Trays

Model no.	Inside height H mm Inch	Thick-ness t mm	Acc. incl.	Weight per 100 pcs kg	Pack/Box Qty
S WHAS 105 S	106,5 4,2	2	4 FLM 8X13 F	58,14	10
E3 WHAS 105 E3	106,5 4,2	2	4 FLM 8X16 E3	58,90	10

for connecting horizontal and vertical runs of long span ladder trays of the same height as well as for wall, box and panel mount

Two pieces required for each connection



82

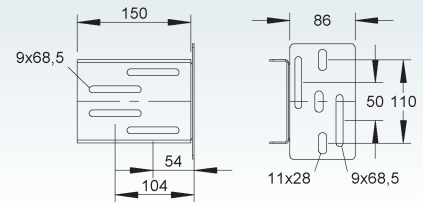
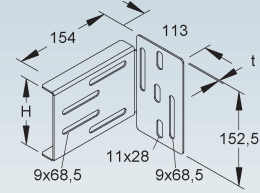

Pair of Protective End Caps

Model no.	Height H mm Inch	Color	Weight per 100 pair kg	Pack/Box Qty
K10 SKWHM 105	105 4,1	yellow	11,12	10 pair

Suitable for: long span cable ladder WSL 105...

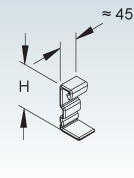
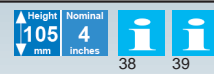

Long Span Cable Tray

ventilated bottom

	Model no.	Height H		Width B		Length L		Thick-ness t	Weight per 100 m	Pack/Box Qty
		mm	Inch	mm	Inch	mm	Inch			
S	WRL 150.200	150	5,9	200	7,9	6000	236,2	1,5	730,04	6 m
S	WRL 150.300	150	5,9	300	11,8	6000	236,2	1,5	790,56	6 m
S	WRL 150.400	150	5,9	400	15,7	6000	236,2	1,5	856,37	6 m
S	WRL 150.500	150	5,9	500	19,7	6000	236,2	1,5	918,24	6 m
S	WRL 150.600	150	5,9	600	23,6	6000	236,2	1,5	993,96	6 m
F	WRL 150.200 F	150	5,9	200	7,9	6000	236,2	1,5	803,82	6 m
F	WRL 150.300 F	150	5,9	300	11,8	6000	236,2	1,5	870,38	6 m
F	WRL 150.400 F	150	5,9	400	15,7	6000	236,2	1,5	942,81	6 m
F	WRL 150.500 F	150	5,9	500	19,7	6000	236,2	1,5	1.010,87	6 m
F	WRL 150.600 F	150	5,9	600	23,6	6000	236,2	1,5	1.094,07	6 m
E3	WRL 150.200 E3	150	5,9	200	7,9	6000	236,2	1,5	735,28	6 m
E3	WRL 150.300 E3	150	5,9	300	11,8	6000	236,2	1,5	796,17	6 m
E3	WRL 150.400 E3	150	5,9	400	15,7	6000	236,2	1,5	861,96	6 m
E3	WRL 150.500 E3	150	5,9	500	19,7	6000	236,2	1,5	924,11	6 m
E3	WRL 150.600 E3	150	5,9	600	23,6	6000	236,2	1,5	1.000,28	6 m

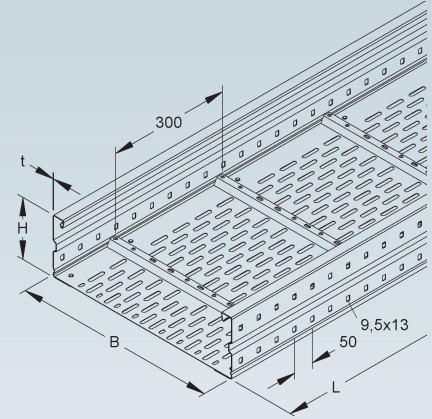
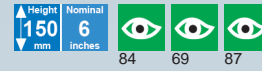

Transversal reinforcing fins in the solid bottom plate are providing extra stability and an easy way to attach dividers.

Also available in 3-meter length.

A bottom connection plate will be supplied for tray in 400, 500 and 600 mm width.

Load Chart: q = uniformly distributed load (tested according to DIN EN IEC 61537 standard)

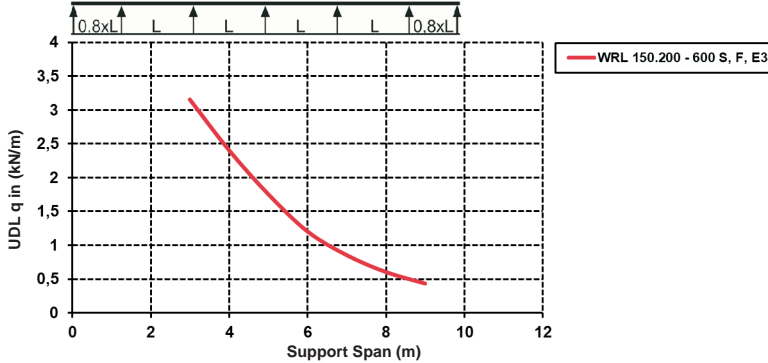

Specified load ratings are independent of splice plate location.

Long Span Cable Tray

solid, but with splice plate perforation

	Model no.	Height H		Width B		Length L		Thick-ness t	Weight per 100 m	Pack/Box Qty
		mm	Inch	mm	Inch	mm	Inch			
S	WRU 150.200	150	5,9	200	7,9	6000	236,2	1,5	755,96	6 m
S	WRU 150.300	150	5,9	300	11,8	6000	236,2	1,5	830,85	6 m
S	WRU 150.400	150	5,9	400	15,7	6000	236,2	1,5	910,82	6 m
S	WRU 150.500	150	5,9	500	19,7	6000	236,2	1,5	986,86	6 m
S	WRU 150.600	150	5,9	600	23,6	6000	236,2	1,5	1.062,81	6 m
F	WRU 150.200 F	150	5,9	200	7,9	6000	236,2	1,5	832,33	6 m
F	WRU 150.300 F	150	5,9	300	11,8	6000	236,2	1,5	914,71	6 m
F	WRU 150.400 F	150	5,9	400	15,7	6000	236,2	1,5	1.002,71	6 m
F	WRU 150.500 F	150	5,9	500	19,7	6000	236,2	1,5	1.086,35	6 m
F	WRU 150.600 F	150	5,9	600	23,6	6000	236,2	1,5	1.169,82	6 m

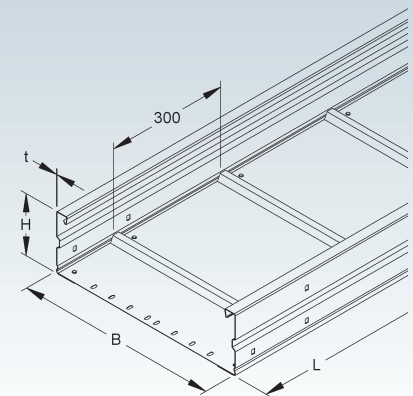

Transversal reinforcing fins in the solid bottom plate are providing extra stability and an easy way to attach dividers.

Also available in 3-meter length.

A bottom connection plate will be supplied for tray in 400, 500 and 600 mm width.

LONG SPAN CABLE TRAY

Long Span Cable Tray

with perforated heavy duty siderails

	Model no.	Height H		Width B		Length L		Thick-ness t	Weight per 100 m	Pack/ Box Qty
		mm	Inch	mm	Inch	mm	Inch			
S	WRLM 150.200	150	5,9	200	7,9	6000	236,2	2	924,72	6 m
S	WRLM 150.300	150	5,9	300	11,8	6000	236,2	2	985,23	6 m
S	WRLM 150.400	150	5,9	400	15,7	6000	236,2	2	1.051,04	6 m
S	WRLM 150.500	150	5,9	500	19,7	6000	236,2	2	1.112,92	6 m
S	WRLM 150.600	150	5,9	600	23,6	6000	236,2	2	1.188,65	6 m
F	WRLM 150.200 F	150	5,9	200	7,9	6000	236,2	2	1.018,03	6 m
F	WRLM 150.300 F	150	5,9	300	11,8	6000	236,2	2	1.084,59	6 m
F	WRLM 150.400 F	150	5,9	400	15,7	6000	236,2	2	1.157,01	6 m
F	WRLM 150.500 F	150	5,9	500	19,7	6000	236,2	2	1.225,07	6 m
F	WRLM 150.600 F	150	5,9	600	23,6	6000	236,2	2	1.308,30	6 m

Transversal reinforcing fins in the ventilated bottom plate are providing extra stability and an easy way to attach dividers.

Also available in 3-meter length.

A bottom connection plate will be supplied for tray in 400, 500 and 600 mm width.

Load Chart: q = uniformly distributed load (tested according to DIN EN IEC 61537 standard)

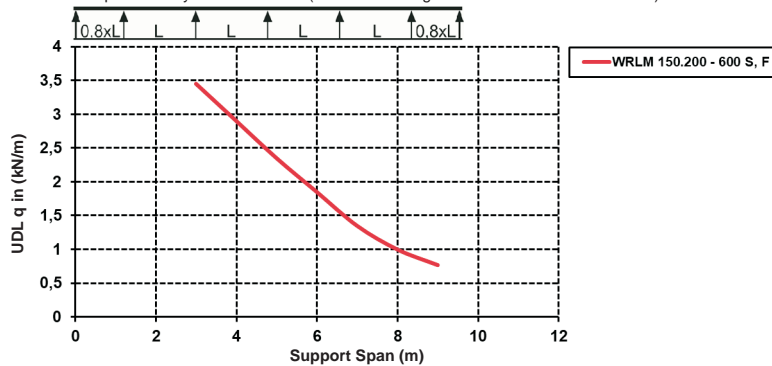

Specified load ratings are independent of splice plate location.

Height 150 mm
Nominal 6 inches
87

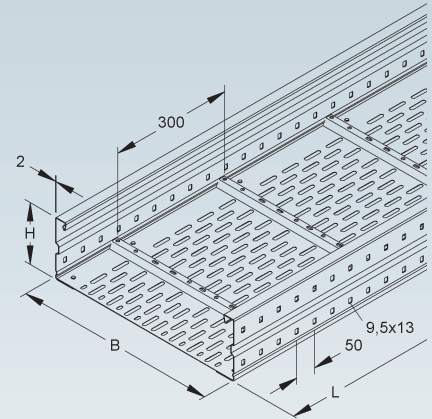

Splice Plate

	Model no.	Inside height H		Width B	Acc. incl.	Weight per 100 pcs	Pack/ Box Qty
		mm	Inch				
S	WSV 150.500	151,5	6	500	4 FLM 8X13 F	183,07	10
F	WSV 150.500 F	151,5	6	500	4 FLM 8X13 F	200,62	10
E3	WSV 150.500 E3	151,5	6	500	4 FLM 8X16 E3	184,51	10

form-locking straight splice plate for long span trays and ladders

2 pieces required per joint

UL classified splice plates ensure electrical continuity and proper bonding.

Height 150 mm
Nominal 6 inches

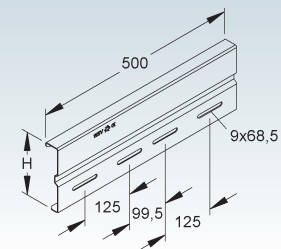

Adjustable Splice Plate

vertical

	Model no.	Inside height H		Acc. incl.	Weight per 100 pcs	Pack/ Box Qty
		mm	Inch			
S	WSGV 150	151,5	6	6 FLM 8X13 F	152,01	1
F	WSGV 150 F	151,5	6	6 FLM 8X13 F	166,01	1
E3	WSGV 150 E3	151,5	6	6 FLM 8X16 E3	152,88	1

2 pieces required per joint

UL classified splice plates ensure electrical continuity and proper bonding.

Height 150 mm
Nominal 6 inches
83

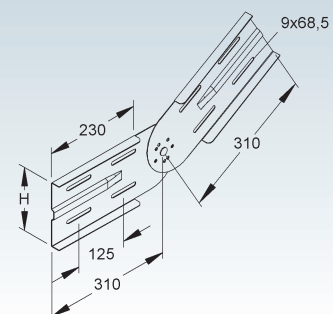

Adjustable Splice Plate

horizontal

Model no.	Inside height H mm Inch	Width B mm Inch	Acc. incl.	Weight per 100 pcs kg	Pack/Box Qty
S WSWV 150	151,5 6	500 19,7	6 FLM 8X13 F	128,75	10
F WSWV 150 F	151,5 6	500 19,7	6 FLM 8X13 F	140,49	10
E3 WSWV 150 E3	151,5 6	500 19,7	6 FLM 8X16 E3	130,70	10

2 pieces required per joint

UL classified splice plates ensure electrical continuity and proper bonding.

Height
150 mm
Nominal
6 inches

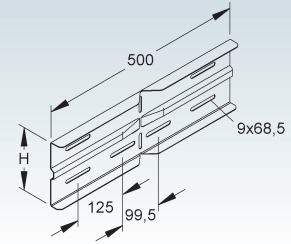

Divider

Model no.	Height H mm Inch	Thickness t mm	Acc. incl.	Weight per 100 m kg	Pack/Box Qty
S RW 110	98 3,9	0,9	4 FLM 6X12	90,29	10 x 3 m
F RW 110 F	98 3,9	0,9	4 FLM 6X12 F	99,21	10 x 3 m
E3 RW 110 E3	98 3,9	0,9	4 FLM 6X12 E3	90,88	10 x 3 m

to separate wires and cables of different voltage levels or with different functions

Height
110 mm
Nominal
4 3/8 inches

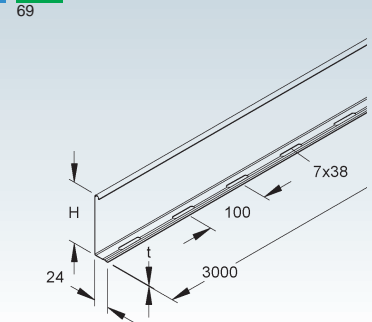

Splice Plate for Divider

Model no.	Height H mm Inch	Length L mm Inch	Weight per 100 pcs kg	Pack/Box Qty
E2 RTV 110 E2	97,5 3,8	80 3,1	2,5	20

for positive locking connections and proper bonding of dividers

Height
110 mm
Nominal
4 3/8 inches

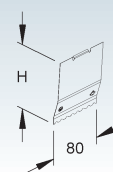

Mounting Clamp for Divider

Model no.	Acc. incl.	Weight per 100 pcs kg	Pack/Box Qty
S KLWC 16	1 FK 6X12 V, GSM 406 G	2,64	50
F KLWC 16 F	1 FK 6X10 E3, GSM 406 E3	2,70	50

Suitable for: divider RW...

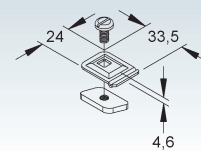

Mounting Clamp for Divider

Model no.	Acc. incl.	Weight per 100 pcs kg	Pack/Box Qty
E3 KLWC 16 E3	1 FK 6X10 E3, GSM 406 E3	3	50

Suitable for: divider RW...

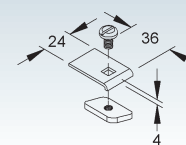

LONG SPAN CABLE TRAY

Extension Horizontal Tee

with integrated splices

	Model no.	Inside height H		Inside dimension B		Acc. incl.	Weight per 100 pcs kg	Pack/ Box Qty
		mm	Inch	mm	Inch			
S	WRTAR 150.200	151,5	6	205	8,1	12 FLM 8X13 F	1.196,97	1
S	WRTAR 150.300	151,5	6	305	12	12 FLM 8X13 F	1.265,55	1
S	WRTAR 150.400	151,5	6	405	15,9	12 FLM 8X13 F	1.334,13	1
S	WRTAR 150.500	151,5	6	505	19,9	12 FLM 8X13 F	1.402,71	1
S	WRTAR 150.600	151,5	6	605	23,8	12 FLM 8X13 F	1.471,29	1
F	WRTAR 150.200 F	151,5	6	205	8,1	12 FLM 8X13 F	1.314,20	1
F	WRTAR 150.300 F	151,5	6	305	12	12 FLM 8X13 F	1.389,64	1
F	WRTAR 150.400 F	151,5	6	405	15,9	12 FLM 8X13 F	1.465,07	1
F	WRTAR 150.500 F	151,5	6	505	19,9	12 FLM 8X13 F	1.540,50	1
F	WRTAR 150.600 F	151,5	6	605	23,8	12 FLM 8X13 F	1.615,94	1
E3	WRTAR 150.200 E3	151,5	6	205	8,1	12 FLM 8X16 E3	1.127,84	1
E3	WRTAR 150.300 E3	151,5	6	305	12	12 FLM 8X16 E3	1.191,42	1
E3	WRTAR 150.400 E3	151,5	6	405	15,9	12 FLM 8X16 E3	1.255,00	1
E3	WRTAR 150.500 E3	151,5	6	505	19,9	12 FLM 8X16 E3	1.412,73	1
E3	WRTAR 150.600 E3	151,5	6	605	23,8	12 FLM 8X16 E3	1.481,74	1

for field manufacturing of horizontal tees and crosses

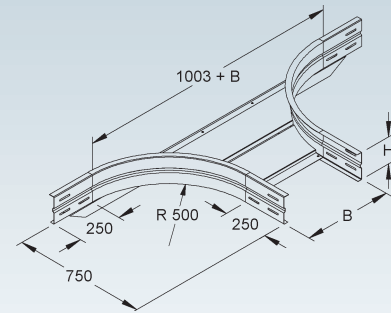

Horizontal Elbow Building Block

with integrated splices

	Model no.	Inside height H		Acc. incl.	Weight per 100 pcs kg	Pack/ Box Qty
		mm	Inch			
S	WAER 150	151,5	6	10 FLM 8X13 F	439,93	1
F	WAER 150 F	151,5	6	10 FLM 8X13 F	481,92	1
E3	WAER 150 E3	151,5	6	10 FLM 8X16 E3	443,34	1

for field manufacturing of longspan elbows and tees

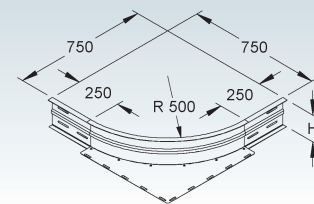

Horizontal Elbow 90°

with solid siderails but prepunched holes for splice plates

	Model no.	Height H		Width B		Weight per 100 pcs kg	Pack/ Box Qty
		mm	Inch	mm	Inch		
S	WRBR 150.200	150	5,9	200	7,9	1.114,20	1
S	WRBR 150.300	150	5,9	300	11,8	1.301,07	1
S	WRBR 150.400	150	5,9	400	15,7	1.500,26	1
S	WRBR 150.500	150	5,9	500	19,7	1.712,16	1
S	WRBR 150.600	150	5,9	600	23,6	1.936,02	1
F	WRBR 150.200 F	150	5,9	200	7,9	1.225,62	1
F	WRBR 150.300 F	150	5,9	300	11,8	1.431,18	1
F	WRBR 150.400 F	150	5,9	400	15,7	1.650,29	1
F	WRBR 150.500 F	150	5,9	500	19,7	1.883,38	1
F	WRBR 150.600 F	150	5,9	600	23,6	2.129,62	1
E3	WRBR 150.200 E3	150	5,9	200	7,9	1.122,53	1
E3	WRBR 150.300 E3	150	5,9	300	11,8	1.310,59	1
E3	WRBR 150.400 E3	150	5,9	400	15,7	1.511,05	1
E3	WRBR 150.500 E3	150	5,9	500	19,7	1.724,51	1
E3	WRBR 150.600 E3	150	5,9	600	23,6	1.949,80	1

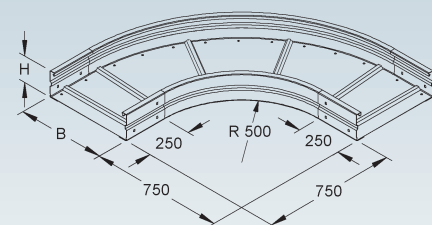
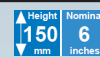

Horizontal Tee

with solid siderails but prepunched holes for splice plates

	Model no.	Height H		Width B		Weight per 100 pcs kg	Pack/Box Qty
		mm	Inch	mm	Inch		
S	WRTR 150.200	150	5,9	200	7,9	1.825,22	1
S	WRTR 150.300	150	5,9	300	11,8	2.073,04	1
S	WRTR 150.400	150	5,9	400	15,7	2.335,23	1
S	WRTR 150.500	150	5,9	500	19,7	2.617,09	1
S	WRTR 150.600	150	5,9	600	23,6	2.908,38	1
F	WRTR 150.200 F	150	5,9	200	7,9	2.007,74	1
F	WRTR 150.300 F	150	5,9	300	11,8	2.280,34	1
F	WRTR 150.400 F	150	5,9	400	15,7	2.568,75	1
F	WRTR 150.500 F	150	5,9	500	19,7	2.878,80	1
F	WRTR 150.600 F	150	5,9	600	23,6	3.199,22	1
E3	WRTR 150.200 E3	150	5,9	200	7,9	1.833,42	1
E3	WRTR 150.300 E3	150	5,9	300	11,8	2.080,25	1
E3	WRTR 150.400 E3	150	5,9	400	15,7	2.341,68	1
E3	WRTR 150.500 E3	150	5,9	500	19,7	2.622,78	1
E3	WRTR 150.600 E3	150	5,9	600	23,6	2.943,78	1

Height 150 mm
Nominal 6 inches

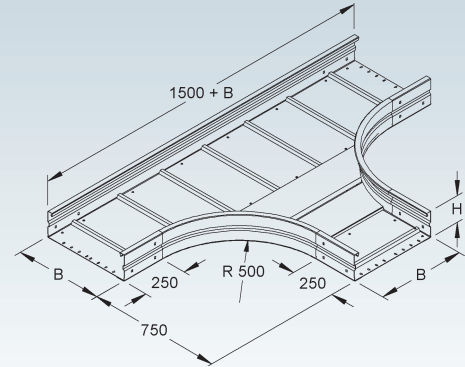

Reducer

	Model no.	Height H		Width B		Weight per 100 pcs kg	Pack/Box Qty
		mm	Inch	mm	Inch		
S	WSRS 150.100 S	150	5,9	100	3,9	53,61	1
S	WSRS 150.150 S	150	5,9	150	5,9	62,20	1
S	WSRS 150.200 S	150	5,9	200	7,9	70,80	1
S	WSRS 150.300 S	150	5,9	300	11,8	87,99	1

can be used as a reducer for long span cable trays and ladders

Height 150 mm
Nominal 6 inches



87

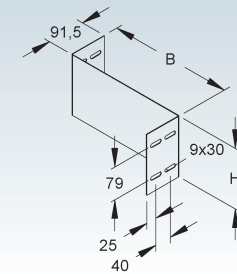

Endplate

	Model no.	Height H		Width B		Weight per 100 pcs kg	Pack/Box Qty
		mm	Inch	mm	Inch		
S	WSAS 150.200 S	150	5,9	200	7,9	71,30	1
S	WSAS 150.300 S	150	5,9	300	11,8	88,50	1
S	WSAS 150.400 S	150	5,9	400	15,7	105,69	1
S	WSAS 150.450 S	150	5,9	450	17,7	114,28	1
S	WSAS 150.500 S	150	5,9	500	19,7	122,88	1
S	WSAS 150.600 S	150	5,9	600	23,6	140,07	1
S	WSAS 150.750 S	150	5,9	750	29,5	165,86	1
S	WSAS 150.900 S	150	5,9	900	35,4	192,00	1

can be used as blind end or as reducer for long span cable trays and ladders

Height 150 mm
Nominal 6 inches



87

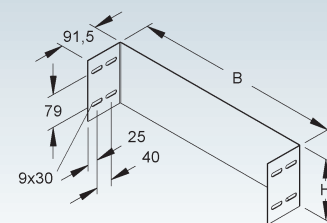

LONG SPAN CABLE TRAY

Wall/Floor and Cross Connector Bracket

for Long Span Ladder Trays

	Model no.	Inside height H		Thick-ness t	Acc. incl.	Weight per 100 pcs kg	Pack/Box Qty
		mm	Inch				
S	WHAS 150 S	151,5	6	2	4 FLM 8X13 F	90,76	10
E3	WHAS 150 E3	151,5	6	2	4 FLM 8X16 E3	91,72	10

for connecting horizontal and vertical runs of long span ladder trays of the same height as well as for wall, box and panel mount

Two pieces required for each connection



82

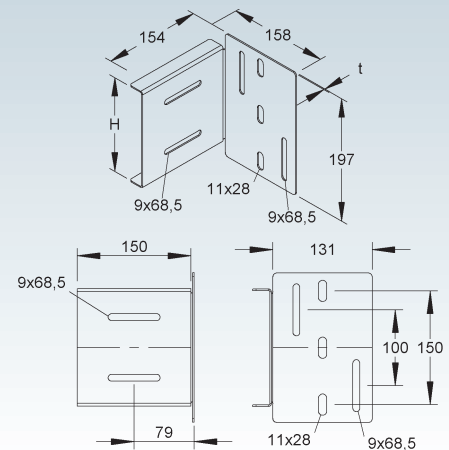

Pair of Protective End Caps

	Model no.	Height H		Color	Weight per 100 pair kg	Pack/Box Qty
		mm	Inch			
K10	SKWHM 150	150	5,9	yellow	6	10 pair

Suitable for: long span cable ladder WSL 150... and WSLM 150...

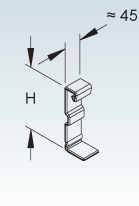

Bottom Connection Plate

	Model no.	Width B		Acc. incl.	Weight per 100 pcs kg	Pack/Box Qty
		mm	Inch			
S	RSL 400	389	15,3	4 FLM 6X12	30,02	1
S	RSL 500	489	19,3	4 FLM 6X12	36,96	1
S	RSL 600	589	23,2	4 FLM 6X12	43,90	1
F	RSL 400 F	389	15,3	4 FLM 6X12 F	32,71	1
F	RSL 500 F	489	19,3	4 FLM 6X12 F	40,34	1
F	RSL 600 F	589	23,2	4 FLM 6X12 F	47,98	1
E3	RSL 400 E3	389	15,3	4 FLM 6X12 E3	27,57	1
E3	RSL 500 E3	489	19,3	4 FLM 6X12 E3	33,86	1
E3	RSL 600 E3	589	23,2	4 FLM 6X12 E3	40,14	1

to stabilize bottom plate joints of long span trays (required only for tray width 400 mm and up)

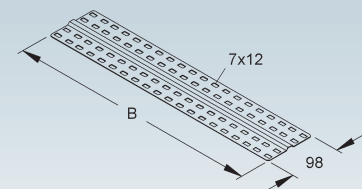

Edge Protection Plate

	Model no.	Width B mm Inch	Acc. incl.	Weight per 100 pcs kg	Pack/Box Qty
S	RKB 200	192 7,6	2 FLM 6X12	9,13	10
S	RKB 300	292 11,5	2 FLM 6X12	13,27	10
S	RKB 400	392 15,4	2 FLM 6X12	17,40	10
S	RKB 500	492 19,4	2 FLM 6X12	21,53	10
S	RKB 600	592 23,3	2 FLM 6X12	25,67	10
F	RKB 200 F	192 7,6	2 FLM 6X12 F	10,13	50
F	RKB 300 F	292 11,5	2 FLM 6X12 F	14,69	50
F	RKB 400 F	392 15,4	2 FLM 6X12 F	19,23	50
F	RKB 500 F	492 19,4	2 FLM 6X12 F	23,77	50
F	RKB 600 F	592 23,3	2 FLM 6X12 F	28,33	50
E3	RKB 200 E3	192 7,6	2 FLM 6X12 E3	9,20	10
E3	RKB 300 E3	292 11,5	2 FLM 6X12 E3	13,36	10
E3	RKB 400 E3	392 15,4	2 FLM 6X12 E3	17,52	10
E3	RKB 500 E3	492 19,4	2 FLM 6X12 E3	21,68	10
E3	RKB 600 E3	592 23,3	2 FLM 6X12 E3	25,84	10

with rounded edges to protect cables at the joint and to reinforce the bottom of cable trays

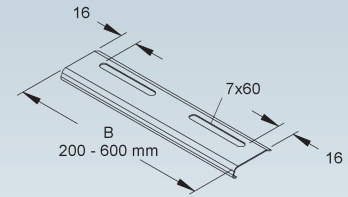

Edge Protection

2 self tapping screws included





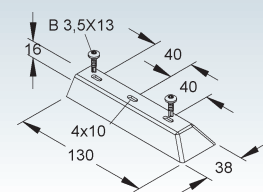























	Model no.	Color	Weight per 100 pcs kg	Pack/Box Qty
K04	WBKS 130 E3	grey	1,42	20

Suitable for: long span cable tray WRL...



LONG SPAN CABLE LADDER

Available Side Rail Heights

SYSTEM				Page 305		Page 310
	Long Span Cable Ladder	WSL...		—		Page 311
	Long Span Cable Ladder	WSLM...		—		Page 311
	Splice Plate	WSV...		Page 305		Page 311
ACCESSORIES	Adjustable Splice Plate	WSGV...		Page 305		Page 311
	Adjustable Splice Plate	WSWV...		Page 306		Page 312
	Extension Horizontal Tee	WSTAR...		Page 307		Page 313
	Horizontal Elbow Building Block	WAER...		Page 307		Page 313
	Horizontal Elbow 90°	WSBR...		Page 307		Page 313
	Horizontal Tee	WSTR...		Page 308		Page 314
	Reducer	WSRS...		Page 308		Page 314
	Endplate	WSAS...		Page 308		Page 314
	Wall/Floor and Cross Connector Bracket	WHAS...		Page 309		Page 315
	Pair of Protective End Caps	SKWHM...		Page 309		Page 315
	Divider	RW...		Page 306/312		
	Splice Plate for Divider	RTV...		Page 306/312		
	Mounting Clamp for Divider	KLWC...		Page 306/312		
	Ladder Drop Out	WLAB...		Page 315		
	Mounting Clamp for Long Span Ladders	WSTB...		Page 315/316		
	Two Hole Corner Angle	WWU 150		Page 316		
	Three Hole Corner Angle	WWA...		Page 316		
	Cover for Long Span Cable Trays/Ladders	WDV...		Page 317		
	Cover for 90° Horizontal Elbow	WBRDV...		Page 317		
	Cover for Horizontal Extension Tee	WTARDV...		Page 318		
	Cover for Horizontal Tee	WTRDV...		Page 318		
	Turnbolt Lock	WDRS 20...		Page 319		
	Raised Cover Clamp	RDAH 30...		Page 319		
	Turnbolt Lock	RDRS 2...		Page 320		
	Protective End Cap	SKSP 70		Page 320		

Support Span L m	WSL 105...		WSL 150...		WSLM 150...	
	q kN/m	F kN	q kN/m	F kN	q kN/m	F kN
3	3,00	9,20	3,15	9,70	3,45	10,65
4	1,70	7,10	2,30	9,55	2,60	10,80
5	1,10	5,85	1,45	7,65	2,00	10,50
6	0,75	4,90	0,85	5,60	1,50	9,60
7	0,55	4,35	0,58	4,65	1,15	8,75
8	0,40	3,75	0,48	4,50	0,90	8,00
9	0,31	3,40	0,43	4,60	0,77	7,85
10	-	-	-	-	-	-
11	-	-	-	-	-	-
12	-	-	-	-	-	-

q = Uniformly distributed load F = Force



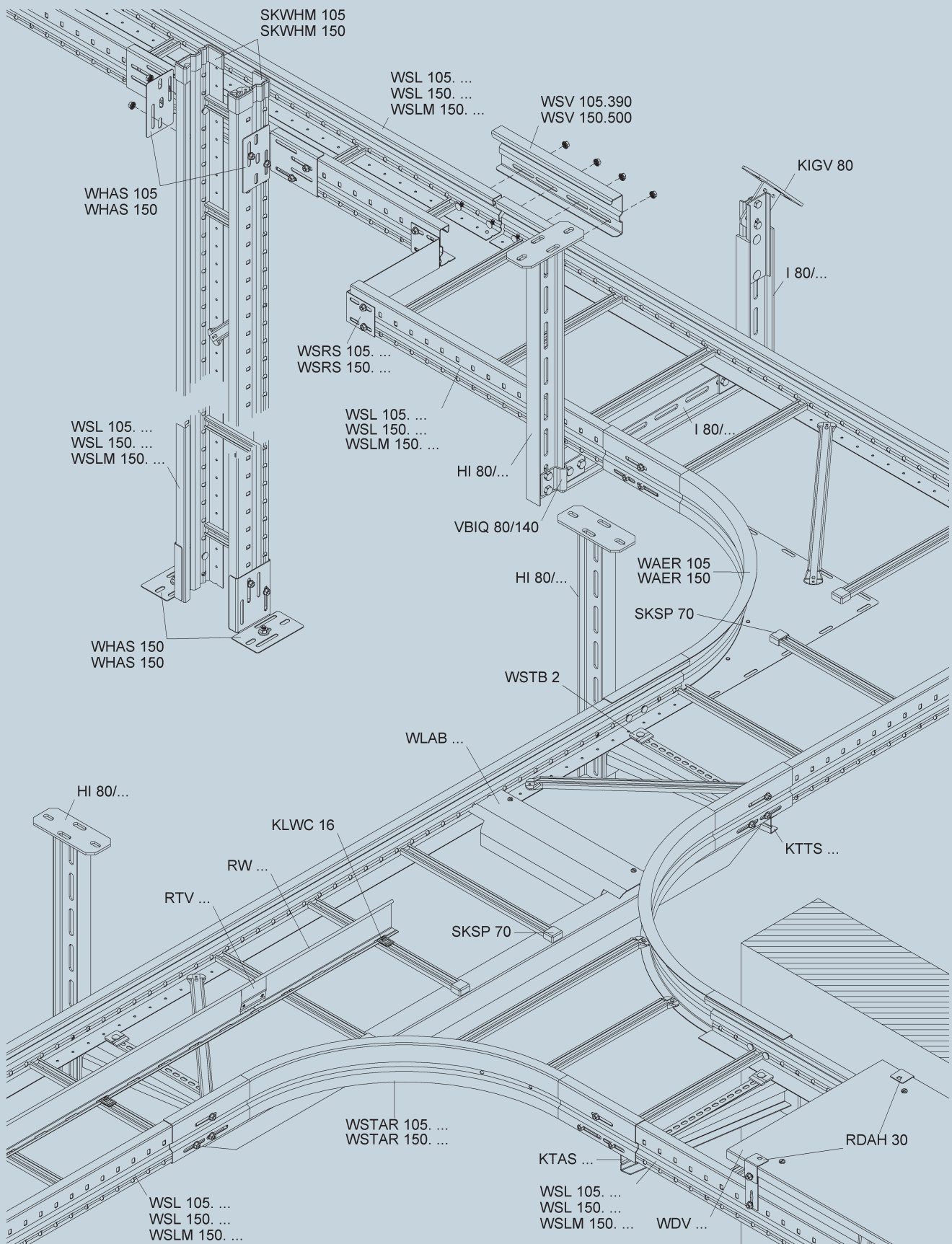

LONG SPAN CABLE LADDER

Load/Span Class Designation in accordance with NEMA VE 1 and CSA C22.2 No. 126.1

Niedax Series	Minimum Area		Load class in accordance to NEMA VE 1		
	(calculational) mm ² / in. ²	in accordance to NEMA VE 2 mm ² / in. ²	Rated Load Kg/m / lb./ft.	Support spacing m / ft.	Load/Span Class
WSLX 105.200, ... F, ... E3	627.0 / 0.97	452 / 0.7	67 / 45	6 / 20	12C, 20AA, D
WSLX 105.300, ... F, ... E3	627.0 / 0.97	452 / 0.7	67 / 45	6 / 20	12C, 20AA, D
WSLX 105.400, ... F, ... E3	627.0 / 0.97	452 / 0.7	67 / 45	6 / 20	12C, 20AA, D
WSLX 105.450, ... F	627.0 / 0.97	452 / 0.7	67 / 45	6 / 20	12C, 20AA, D
WSLX 105.500, ... F, ... E3	627.0 / 0.97	452 / 0.7	67 / 45	6 / 20	12C, 20AA, D
WSLX 105.600, ... F, ... E3	627.0 / 0.97	452 / 0.7	67 / 45	6 / 20	12C, 20AA, D
WSLX 150.200, ... F, ... E3	762.0 / 1.18	645 / 1.0	73 / 49	6 / 20	12C, 20AA, D
WSLX 150.300, ... F, ... E3	762.0 / 1.18	645 / 1.0	73 / 49	6 / 20	12C, 20AA, D
WSLX 150.400, ... F, ... E3	762.0 / 1.18	645 / 1.0	73 / 49	6 / 20	12C, 20AA, D
WSLX 150.450, ... F	762.0 / 1.18	645 / 1.0	73 / 49	6 / 20	12C, 20AA, D
WSLX 150.500, ... F, ... E3	762.0 / 1.18	645 / 1.0	73 / 49	6 / 20	12C, 20AA, D
WSLX 150.600, ... F, ... E3	762.0 / 1.18	645 / 1.0	73 / 49	6 / 20	12C, 20AA, D
WSLX 150.750	762.0 / 1.18	645 / 1.0	73 / 49	6 / 20	12C, 20AA, D
WSLX 150.900, ... F	762.0 / 1.18	645 / 1.0	73 / 49	6 / 20	12C, 20AA, D
WSLMX 150.200, ... F	896 / 1.39	645 / 1.0	122 / 82	6 / 20	12C, 20B, E
WSLMX 150.300, ... F	896 / 1.39	645 / 1.0	122 / 82	6 / 20	12C, 20B, E
WSLMX 150.400, ... F	896 / 1.39	645 / 1.0	122 / 82	6 / 20	12C, 20B, E
WSLMX 150.450, ... F	896 / 1.39	645 / 1.0	122 / 82	6 / 20	12C, 20B, E
WSLMX 150.500, ... F	896 / 1.39	645 / 1.0	122 / 82	6 / 20	12C, 20B, E
WSLMX 150.600, ... F	896 / 1.39	645 / 1.0	122 / 82	6 / 20	12C, 20B, E
WSLMX 150.750	896 / 1.39	645 / 1.0	122 / 82	6 / 20	12C, 20B, E
WSLMX 150.900, ... F	896 / 1.39	645 / 1.0	122 / 82	6 / 20	12C, 20B, E



Long Span Cable Ladder

C-channel rungs with 16 mm slot width, standard spacing 300 mm

	Model no.	Height H		Width B		Length L		Thick-ness t mm	Weight per 100 m kg	Pack/Box Qty
		mm	Inch	mm	Inch	mm	Inch			
S	WSL 105.200	105	4,1	200	7,9	6000	236,2	1,5	546,14	6 m
S	WSL 105.300	105	4,1	300	11,8	6000	236,2	1,5	573,36	6 m
S	WSL 105.400	105	4,1	400	15,7	6000	236,2	1,5	600,58	6 m
S	WSL 105.450	105	4,1	450	17,7	6000	236,2	1,5	614,17	6 m
S	WSL 105.500	105	4,1	500	19,7	6000	236,2	1,5	626,04	6 m
S	WSL 105.600	105	4,1	600	23,6	6000	236,2	1,5	653,26	6 m
F	WSL 105.200 F	105	4,1	200	7,9	6000	236,2	1,5	601,32	6 m
F	WSL 105.300 F	105	4,1	300	11,8	6000	236,2	1,5	631,26	6 m
F	WSL 105.400 F	105	4,1	400	15,7	6000	236,2	1,5	661,20	6 m
F	WSL 105.450 F	105	4,1	450	17,7	6000	236,2	1,5	675,59	6 m
F	WSL 105.500 F	105	4,1	500	19,7	6000	236,2	1,5	689,21	6 m
F	WSL 105.600 F	105	4,1	600	23,6	6000	236,2	1,5	719,15	6 m
E3	WSL 105.200 E3	105	4,1	200	7,9	6000	236,2	1,5	549,63	6 m
E3	WSL 105.300 E3	105	4,1	300	11,8	6000	236,2	1,5	577,02	6 m
E3	WSL 105.400 E3	105	4,1	400	15,7	6000	236,2	1,5	604,41	6 m
E3	WSL 105.500 E3	105	4,1	500	19,7	6000	236,2	1,5	630,04	6 m
E3	WSL 105.600 E3	105	4,1	600	23,6	6000	236,2	1,5	657,43	6 m

Also available in 3-meter length and with 150 mm (6") or 200 mm (8") rung spacing.

Load Chart: q = uniformly distributed load (tested according to DIN EN IEC 61537 standard)

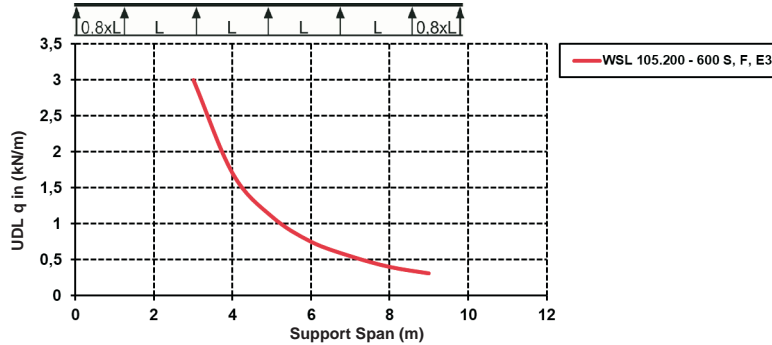

Specified load ratings are independent of splice plate location.

Height 105 mm
Nominal 4 inches
69 83

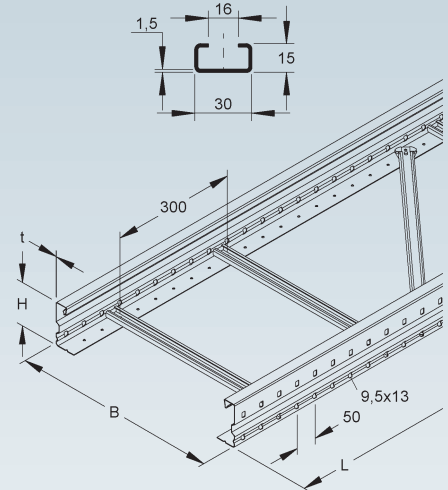

Splice Plate

	Model no.	Inside height H		Width B	Acc. incl.	Weight per 100 pcs kg	Pack/Box Qty	
		mm	Inch					
S	WSV 105.390	106,5	4,2	390	15,4	4 FLM 8X13 F	116,04	10
F	WSV 105.390 F	106,5	4,2	390	15,4	4 FLM 8X13 F	126,88	10
E3	WSV 105.390 E3	106,5	4,2	390	15,4	4 FLM 8X16 E3	117,05	10

form-locking straight splice plate for long span trays and ladders

2 pieces required per joint

UL classified splice plates ensure electrical continuity and proper bonding.

Height 105 mm
Nominal 4 inches

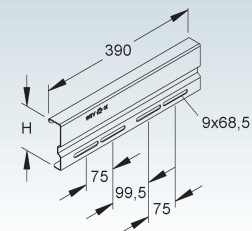

Adjustable Splice Plate

vertical

	Model no.	Inside height H		Acc. incl.	Weight per 100 pcs kg	Pack/Box Qty
		mm	Inch			
S	WSGV 105	106,5	4,2	6 FLM 8X13 F	91,97	1
F	WSGV 105 F	106,5	4,2	6 FLM 8X13 F	99,97	1
E3	WSGV 105 E3	106,5	4,2	6 FLM 8X16 E3	92,46	1

2 pieces required per joint

UL classified splice plates ensure electrical continuity and proper bonding.

Height 105 mm
Nominal 4 inches

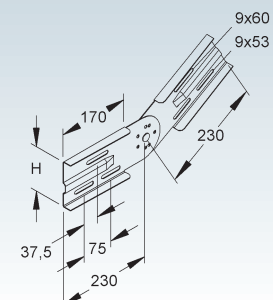

LONG SPAN CABLE LADDER

Adjustable Splice Plate

horizontal

	Model no.	Inside height H mm Inch	Width B mm Inch	Acc. incl.	Weight per 100 pcs kg	Pack/Box Qty
S	WSWV 105.390	106,5 4,2	390 15,4	6 FLM 8X13 F	92,46	10
F	WSWV 105.390 F	106,5 4,2	390 15,4	6 FLM 8X13 F	100,57	10
E3	WSWV 105.390 E3	106,5 4,2	390 15,4	6 FLM 8X16 E3	82,33	10

2 pieces required per joint

UL classified splice plates ensure electrical continuity and proper bonding.

Height
105 mm
Nominal
4 inches

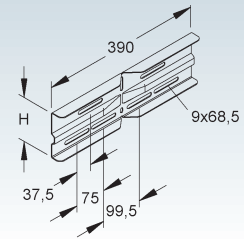

Divider

	Model no.	Height H mm Inch	Thickness t mm	Acc. incl.	Weight per 100 m kg	Pack/Box Qty
S	RW 85	80 3,1	0,9	4 FLM 6X12	77,65	10 x 3 m
F	RW 85 F	80 3,1	0,9	4 FLM 6X12 F	85,30	10 x 3 m
E3	RW 85 E3	80 3,1	0,9	4 FLM 6X12 E3	78,17	10 x 3 m

to separate wires and cables of different voltage levels or with different functions

Height
85 mm
Nominal
3 3/8 inches



69

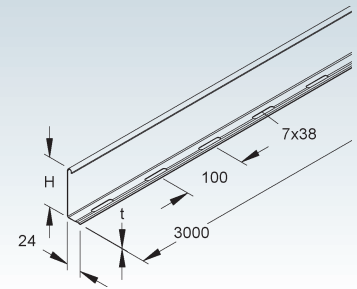

Splice Plate for Divider

	Model no.	Height H mm Inch	Length L mm Inch	Weight per 100 pcs kg	Pack/Box Qty
E2	RTV 85 E2	79,5 3,1	80 3,1	2,03	20

for positive locking connections and proper bonding of dividers

Height
85 mm
Nominal
3 3/8 inches



69

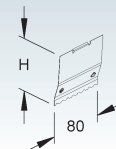

Mounting Clamp for Divider

	Model no.	Acc. incl.	Weight per 100 pcs kg	Pack/Box Qty
S	KLWC 16	1 FK 6X12 V, GSM 406 G	2,64	50
F	KLWC 16 F	1 FK 6X10 E3, GSM 406 E3	2,70	50

Suitable for: divider RW...



69

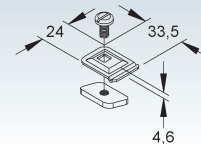

Mounting Clamp for Divider

	Model no.	Acc. incl.	Weight per 100 pcs kg	Pack/Box Qty
E3	KLWC 16 E3	1 FK 6X10 E3, GSM 406 E3	3	50

Suitable for: divider RW...



69

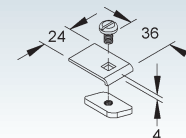

Extension Horizontal Tee

with integrated splices

Model no.		Inside height H	Inside dimension B	Acc. incl.	Weight per 100 pcs kg	Pack/Box Qty
		mm Inch	mm Inch			
S	WSTAR 105.200	106,5 4,2	205 8,1	12 FLM 8X13 F	973,66	1
S	WSTAR 105.300	106,5 4,2	305 12	12 FLM 8X13 F	1.010,26	1
S	WSTAR 105.400	106,5 4,2	405 15,9	12 FLM 8X13 F	1.047,84	1
S	WSTAR 105.450	106,5 4,2	455 17,9	12 FLM 8X13 F	1.066,82	1
S	WSTAR 105.500	106,5 4,2	505 19,9	12 FLM 8X13 F	1.087,15	1
S	WSTAR 105.600	106,5 4,2	605 23,8	12 FLM 8X13 F	1.119,46	1
F	WSTAR 105.200 F	106,5 4,2	205 8,1	12 FLM 8X13 F	1.068,63	1
F	WSTAR 105.300 F	106,5 4,2	305 12	12 FLM 8X13 F	1.108,89	1
F	WSTAR 105.400 F	106,5 4,2	405 15,9	12 FLM 8X13 F	1.150,22	1
F	WSTAR 105.450 F	106,5 4,2	455 17,9	12 FLM 8X13 F	1.171,10	1
F	WSTAR 105.500 F	106,5 4,2	505 19,9	12 FLM 8X13 F	1.193,47	1
F	WSTAR 105.600 F	106,5 4,2	605 23,8	12 FLM 8X13 F	1.229,01	1
E3	WSTAR 105.200 E3	106,5 4,2	205 8,1	12 FLM 8X16 E3	818,80	1
E3	WSTAR 105.300 E3	106,5 4,2	305 12	12 FLM 8X16 E3	850,35	1
E3	WSTAR 105.400 E3	106,5 4,2	405 15,9	12 FLM 8X16 E3	881,90	1
E3	WSTAR 105.500 E3	106,5 4,2	505 19,9	12 FLM 8X16 E3	1.010,74	1
E3	WSTAR 105.600 E3	106,5 4,2	605 23,8	12 FLM 8X16 E3	1.042,76	1

for field manufacturing of horizontal tees and crosses

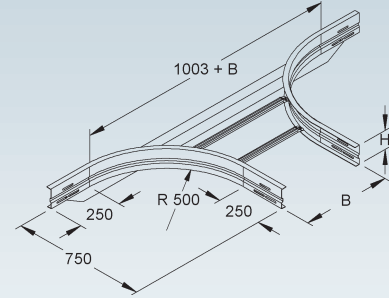

Horizontal Elbow Building Block

with integrated splices

Model no.		Inside height H	Acc. incl.	Weight per 100 pcs kg	Pack/Box Qty
		mm Inch			
S	WAER 105	106,5 4,2	10 FLM 8X13 F	413,30	1
F	WAER 105 F	106,5 4,2	10 FLM 8X13 F	452,63	1
E3	WAER 105 E3	106,5 4,2	10 FLM 8X16 E3	374,73	1

for field manufacturing of longspan elbows and tees

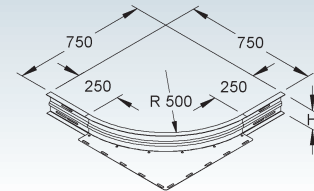

Horizontal Elbow 90°

with solid siderails but prepunched holes for splice plates

Model no.		Height H	Width B	Weight per 100 pcs kg	Pack/Box Qty
		mm Inch	mm Inch		
S	WSBR 105.200	105 4,1	200 7,9	830,73	1
S	WSBR 105.300	105 4,1	300 11,8	923,31	1
S	WSBR 105.400	105 4,1	400 15,7	1.015,90	1
S	WSBR 105.450	105 4,1	450 17,7	1.062,19	1
S	WSBR 105.500	105 4,1	500 19,7	1.108,48	1
S	WSBR 105.600	105 4,1	600 23,6	1.201,07	1
F	WSBR 105.200 F	105 4,1	200 7,9	913,80	1
F	WSBR 105.300 F	105 4,1	300 11,8	1.015,64	1
F	WSBR 105.400 F	105 4,1	400 15,7	1.117,49	1
F	WSBR 105.450 F	105 4,1	450 17,7	1.168,41	1
F	WSBR 105.500 F	105 4,1	500 19,7	1.219,33	1
F	WSBR 105.600 F	105 4,1	600 23,6	1.321,18	1
E3	WSBR 105.200 E3	105 4,1	200 7,9	836,04	1
E3	WSBR 105.300 E3	105 4,1	300 11,8	929,21	1
E3	WSBR 105.400 E3	105 4,1	400 15,7	1.022,39	1
E3	WSBR 105.500 E3	105 4,1	500 19,7	1.115,56	1
E3	WSBR 105.600 E3	105 4,1	600 23,6	1.208,74	1

WSV 105.390 splice plates have to be ordered separately.

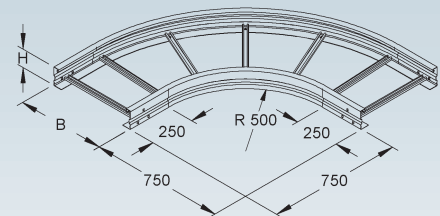

LONG SPAN CABLE LADDER

Horizontal Tee

with solid siderails but prepunched holes for splice plates

	Model no.	Height H		Width B		Weight per 100 pcs kg	Pack/Box Qty
		mm	Inch	mm	Inch		
S	WSTR 105.200	105	4,1	200	7,9	1.324,57	1
S	WSTR 105.300	105	4,1	300	11,8	1.425,32	1
S	WSTR 105.400	105	4,1	400	15,7	1.583,86	1
S	WSTR 105.450	105	4,1	450	17,7	1.641,58	1
S	WSTR 105.500	105	4,1	500	19,7	1.774,73	1
S	WSTR 105.600	105	4,1	600	23,6	1.897,71	1
F	WSTR 105.200 F	105	4,1	200	7,9	1.457,03	1
F	WSTR 105.300 F	105	4,1	300	11,8	1.567,85	1
F	WSTR 105.400 F	105	4,1	400	15,7	1.742,25	1
F	WSTR 105.450 F	105	4,1	450	17,7	1.805,74	1
F	WSTR 105.500 F	105	4,1	500	19,7	1.952,20	1
F	WSTR 105.600 F	105	4,1	600	23,6	2.087,48	1
E3	WSTR 105.200 E3	105	4,1	200	7,9	1.333,04	1
E3	WSTR 105.300 E3	105	4,1	300	11,8	1.434,43	1
E3	WSTR 105.400 E3	105	4,1	400	15,7	1.593,97	1
E3	WSTR 105.500 E3	105	4,1	500	19,7	1.786,07	1
E3	WSTR 105.600 E3	105	4,1	600	23,6	1.909,83	1

WSV 105.390 splice plates have to be ordered separately.

Height 105 mm
Nominal 4 inches

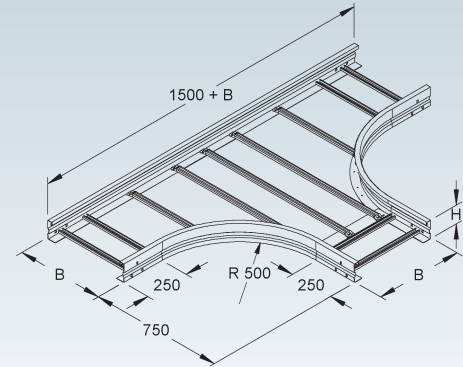

Reducer

	Model no.	Height H		Width B		Weight per 100 pcs kg	Pack/Box Qty
		mm	Inch	mm	Inch		
S	WSRS 105.100 S	105	4,1	100	3,9	32,70	1
S	WSRS 105.150 S	105	4,1	150	5,9	37,53	1
S	WSRS 105.200 S	105	4,1	200	7,9	42,23	1
S	WSRS 105.300 S	105	4,1	300	11,8	52,01	1

can be used as a reducer for long span cable trays and ladders

Height 105 mm
Nominal 4 inches

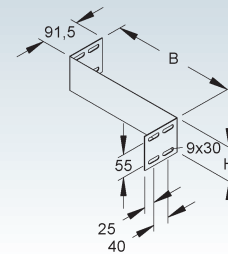

Endplate

	Model no.	Height H		Width B		Weight per 100 pcs kg	Pack/Box Qty
		mm	Inch	mm	Inch		
S	WSAS 105.200 S	102	4	200	7,9	51,63	1
S	WSAS 105.300 S	102	4	300	11,8	63,64	1
S	WSAS 105.400 S	102	4	400	15,7	75,65	1
S	WSAS 105.450 S	102	4	450	17,7	81,66	1
S	WSAS 105.500 S	102	4	500	19,7	87,66	1
S	WSAS 105.600 S	102	4	600	23,6	99,67	1

can be used as blind end or as reducer for long span cable trays and ladders

Height 105 mm
Nominal 4 inches

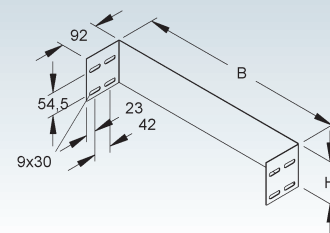

Wall/Floor and Cross Connector Bracket

for Long Span Ladder Trays

Model no.	Inside height H mm Inch	Thick-ness t mm	Acc. incl.	Weight per 100 pcs kg	Pack/Box Qty
S WHAS 105 S	106,5 4,2	2	4 FLM 8X13 F	58,14	10
E3 WHAS 105 E3	106,5 4,2	2	4 FLM 8X16 E3	58,90	10

for connecting horizontal and vertical runs of long span ladder trays of the same height as well as for wall, box and panel mount

Two pieces required for each connection



82

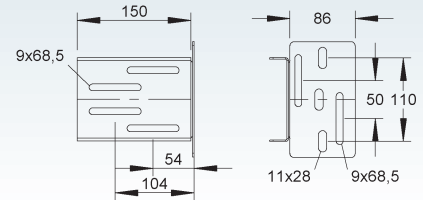
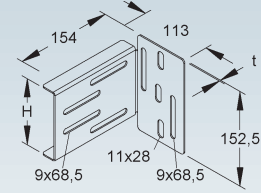

Pair of Protective End Caps

Model no.	Height H mm Inch	Color	Weight per 100 pair kg	Pack/Box Qty
K10 SKWHM 105	105 4,1	yellow	11,12	10 pair

Suitable for: long span cable ladder WSL 105...

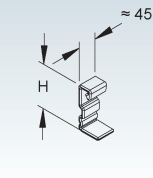
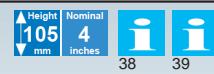

LONG SPAN CABLE LADDER

Long Span Cable Ladder

C-channel rungs with 16 mm slot width, standard spacing 300 mm

	Model no.	Height H		Width B		Length L		Thick-ness t mm	Weight per 100 m kg	Pack/Box Qty
		mm	Inch	mm	Inch	mm	Inch			
S	WSL 150.200	150	5,9	200	7,9	6000	236,2	1,5	652,55	6 m
S	WSL 150.300	150	5,9	300	11,8	6000	236,2	1,5	679,77	6 m
S	WSL 150.400	150	5,9	400	15,7	6000	236,2	1,5	706,99	6 m
S	WSL 150.450	150	5,9	450	17,7	6000	236,2	1,5	720,58	6 m
S	WSL 150.500	150	5,9	500	19,7	6000	236,2	1,5	732,45	6 m
S	WSL 150.600	150	5,9	600	23,6	6000	236,2	1,5	759,67	6 m
S	WSL 150.750	150	5,9	750	29,5	6000	236,2	1,5	959,79	6 m
S	WSL 150.900	150	5,9	900	35,4	6000	236,2	1,5	1.029,47	6 m
F	WSL 150.200 F	150	5,9	200	7,9	6000	236,2	1,5	718,37	6 m
F	WSL 150.300 F	150	5,9	300	11,8	6000	236,2	1,5	748,31	6 m
F	WSL 150.400 F	150	5,9	400	15,7	6000	236,2	1,5	778,25	6 m
F	WSL 150.450 F	150	5,9	450	17,7	6000	236,2	1,5	792,64	6 m
F	WSL 150.500 F	150	5,9	500	19,7	6000	236,2	1,5	806,26	6 m
F	WSL 150.600 F	150	5,9	600	23,6	6000	236,2	1,5	836,20	6 m
E3	WSL 150.200 E3	150	5,9	200	7,9	6000	236,2	1,5	656,71	6 m
E3	WSL 150.300 E3	150	5,9	300	11,8	6000	236,2	1,5	684,11	6 m
E3	WSL 150.400 E3	150	5,9	400	15,7	6000	236,2	1,5	711,50	6 m
E3	WSL 150.500 E3	150	5,9	500	19,7	6000	236,2	1,5	737,13	6 m
E3	WSL 150.600 E3	150	5,9	600	23,6	6000	236,2	1,5	764,52	6 m

Also available in 3-meter length and with 150 mm (6") or 200 mm (8") rung spacing.

Load Chart: q = uniformly distributed load (tested according to DIN EN IEC 61537 standard)

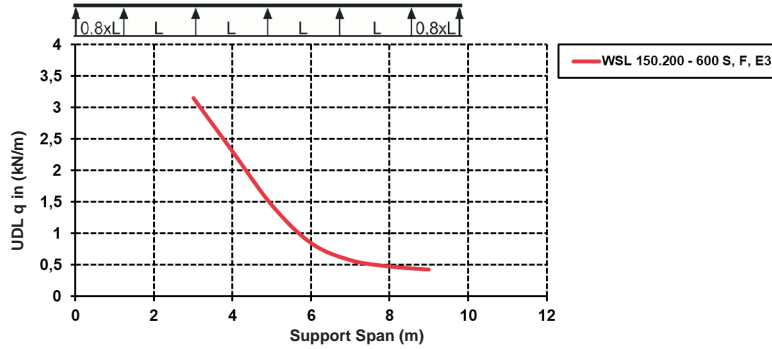

Specified load ratings are independent of splice plate location.

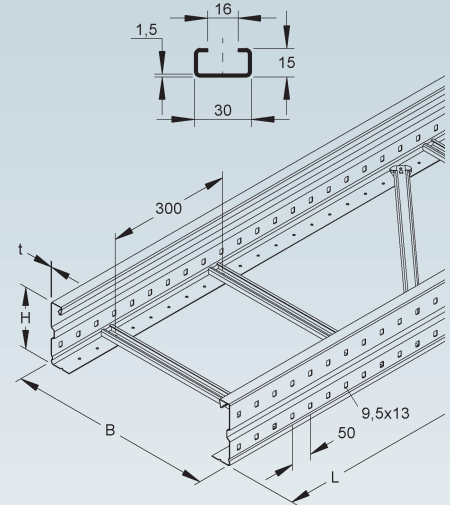
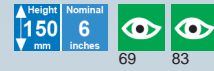

Long Span Cable Ladder

C-channel rungs with 16 mm slot width, standard spacing 300 mm

	Model no.	Height H		Width B		Length L		Thick-ness t mm	Weight per 100 m kg	Pack/Box Qty
		mm	Inch	mm	Inch	mm	Inch			
S	WSLM 150.200	150	5,9	200	7,9	6000	236,2	2	846,85	6 m
S	WSLM 150.300	150	5,9	300	11,8	6000	236,2	2	874,07	6 m
S	WSLM 150.400	150	5,9	400	15,7	6000	236,2	2	901,29	6 m
S	WSLM 150.450	150	5,9	450	17,7	6000	236,2	2	914,89	6 m
S	WSLM 150.500	150	5,9	500	19,7	6000	236,2	2	926,76	6 m
S	WSLM 150.600	150	5,9	600	23,6	6000	236,2	2	953,98	6 m
S	WSLM 150.750	150	5,9	750	29,5	6000	236,2	2	1.120,55	6 m
S	WSLM 150.900	150	5,9	900	35,4	6000	236,2	2	1.223,78	6 m
F	WSLM 150.200 F	150	5,9	200	7,9	6000	236,2	2	931,54	6 m
F	WSLM 150.300 F	150	5,9	300	11,8	6000	236,2	2	961,48	6 m
F	WSLM 150.400 F	150	5,9	400	15,7	6000	236,2	2	991,42	6 m
F	WSLM 150.450 F	150	5,9	450	17,7	6000	236,2	2	1.005,29	6 m
F	WSLM 150.500 F	150	5,9	500	19,7	6000	236,2	2	1.019,43	6 m
F	WSLM 150.600 F	150	5,9	600	23,6	6000	236,2	2	1.049,37	6 m

Also available in 3-meter length and with 150 mm (6") or 200 mm (8") rung spacing.

Load Chart: q = uniformly distributed load (tested according to DIN EN IEC 61537 standard)

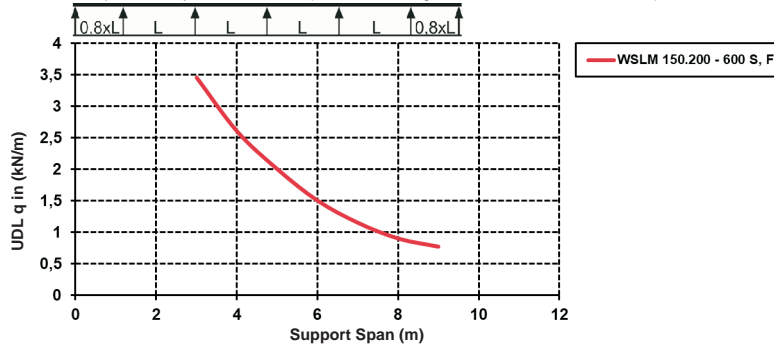

Specified load ratings are independent of splice plate location.

Height 150 mm
Nominal 6 inches
Eye icon
83

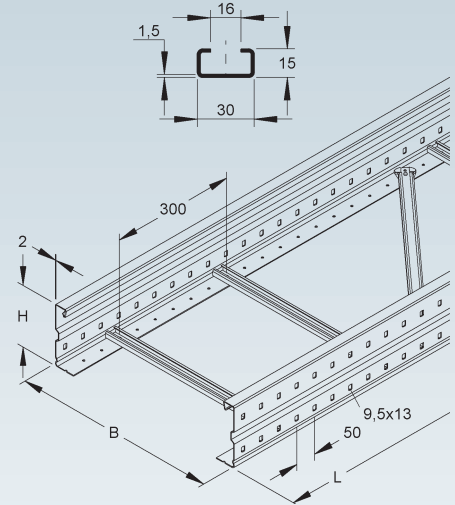

Splice Plate

	Model no.	Inside height H		Width B	Acc. incl.	Weight per 100 pcs kg	Pack/Box Qty
		mm	Inch				
S	WSV 150.500	151,5	6	500	4 FLM 8X13 F	183,07	10
F	WSV 150.500 F	151,5	6	500	4 FLM 8X13 F	200,62	10
E3	WSV 150.500 E3	151,5	6	500	4 FLM 8X16 E3	184,51	10

form-locking straight splice plate for long span trays and ladders

2 pieces required per joint

UL classified splice plates ensure electrical continuity and proper bonding.

Height 150 mm
Nominal 6 inches

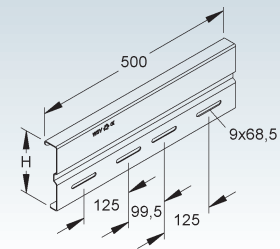

Adjustable Splice Plate

vertical

	Model no.	Inside height H		Acc. incl.	Weight per 100 pcs kg	Pack/Box Qty
		mm	Inch			
S	WSGV 150	151,5	6	6 FLM 8X13 F	152,01	1
F	WSGV 150 F	151,5	6	6 FLM 8X13 F	166,01	1
E3	WSGV 150 E3	151,5	6	6 FLM 8X16 E3	152,88	1

2 pieces required per joint

UL classified splice plates ensure electrical continuity and proper bonding.

Height 150 mm
Nominal 6 inches
Eye icon
83

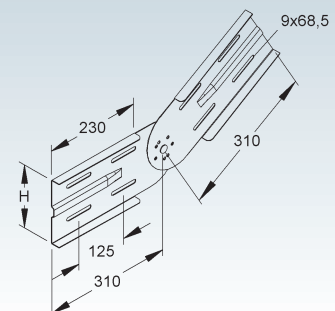

LONG SPAN CABLE LADDER

Adjustable Splice Plate

horizontal

	Model no.	Inside height H		Width B		Acc. incl.	Weight per 100 pcs kg	Pack/Box Qty
		mm	Inch	mm	Inch			
S	WSWV 150	151,5	6	500	19,7	6 FLM 8X13 F	128,75	10
F	WSWV 150 F	151,5	6	500	19,7	6 FLM 8X13 F	140,49	10
E3	WSWV 150 E3	151,5	6	500	19,7	6 FLM 8X16 E3	130,70	10

2 pieces required per joint

UL classified splice plates ensure electrical continuity and proper bonding.

Height
150 mm
Nominal
6 inches

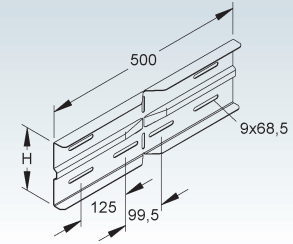

Divider

	Model no.	Height H		Thick-ness t	Acc. incl.	Weight per 100 m kg	Pack/Box Qty
		mm	Inch				
S	RW 110	98	3,9	0,9	4 FLM 6X12	90,29	10 x 3 m
F	RW 110 F	98	3,9	0,9	4 FLM 6X12 F	99,21	10 x 3 m
E3	RW 110 E3	98	3,9	0,9	4 FLM 6X12 E3	90,88	10 x 3 m

to separate wires and cables of different voltage levels or with different functions

Height
110 mm
Nominal
4 3/8 inches



69

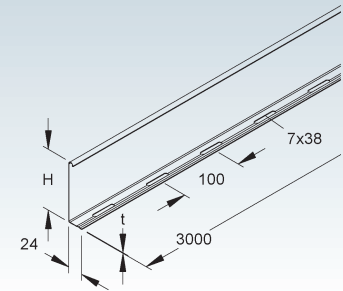

Splice Plate for Divider

	Model no.	Height H		Length L	Weight per 100 pcs kg	Pack/Box Qty
		mm	Inch			
E2	RTV 110 E2	97,5	3,8	80	2,5	20

for positive locking connections and proper bonding of dividers

Height
110 mm
Nominal
4 3/8 inches



69

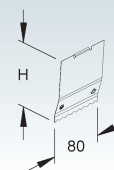

Mounting Clamp for Divider

	Model no.	Acc. incl.		Weight per 100 pcs kg	Pack/Box Qty
S	KLWC 16	1 FK 6X12 V, GSM 406 G		2,64	50
F	KLWC 16 F	1 FK 6X10 E3, GSM 406 E3		2,70	50

Suitable for: divider RW...



69

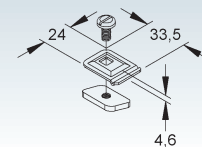

Mounting Clamp for Divider

	Model no.	Acc. incl.		Weight per 100 pcs kg	Pack/Box Qty
E3	KLWC 16 E3	1 FK 6X10 E3, GSM 406 E3		3	50

Suitable for: divider RW...



69

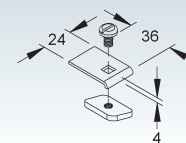

Extension Horizontal Tee

with integrated splices

	Model no.	Inside height H		Inside dimension B		Acc. incl.	Weight per 100 pcs/kg	Pack/Box Qty
		mm	Inch	mm	Inch			
S	WSTAR 150.200	151,5	6	205	8,1	12 FLM 8X13 F	1.026,89	1
S	WSTAR 150.300	151,5	6	305	12	12 FLM 8X13 F	1.063,49	1
S	WSTAR 150.400	151,5	6	405	15,9	12 FLM 8X13 F	1.101,07	1
S	WSTAR 150.450	151,5	6	455	17,9	12 FLM 8X13 F	1.120,05	1
S	WSTAR 150.500	151,5	6	505	19,9	12 FLM 8X13 F	1.140,38	1
S	WSTAR 150.600	151,5	6	605	23,8	12 FLM 8X13 F	1.172,69	1
S	WSTAR 150.750	151,5	6	755	29,7	12 FLM 8X13 F	1.347,50	1
S	WSTAR 150.900	151,5	6	905	35,6	12 FLM 8X13 F	1.423,22	1
F	WSTAR 150.200 F	151,5	6	205	8,1	12 FLM 8X13 F	1.127,18	1
F	WSTAR 150.300 F	151,5	6	305	12	12 FLM 8X13 F	1.167,44	1
F	WSTAR 150.400 F	151,5	6	405	15,9	12 FLM 8X13 F	1.208,78	1
F	WSTAR 150.450 F	151,5	6	455	17,9	12 FLM 8X13 F	1.229,66	1
F	WSTAR 150.500 F	151,5	6	505	19,9	12 FLM 8X13 F	1.252,02	1
F	WSTAR 150.600 F	151,5	6	605	23,8	12 FLM 8X13 F	1.287,56	1

for field manufacturing of horizontal tees and crosses

Height 150 mm
Nominal 6 inches
84

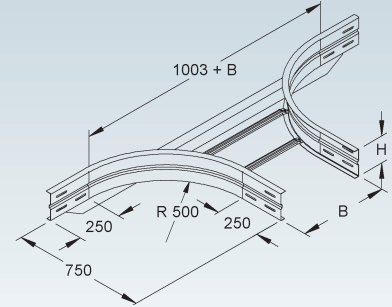

Horizontal Elbow Building Block

with integrated splices

	Model no.	Inside height H		Acc. incl.	Weight per 100 pcs/kg	Pack/Box Qty
		mm	Inch			
S	WAER 150	151,5	6	10 FLM 8X13 F	439,93	1
F	WAER 150 F	151,5	6	10 FLM 8X13 F	481,92	1
E3	WAER 150 E3	151,5	6	10 FLM 8X16 E3	443,34	1

for field manufacturing of longspan elbows and tees

Height 150 mm
Nominal 6 inches

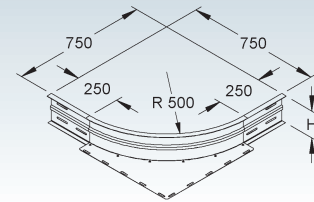

Horizontal Elbow 90°

with solid siderails but prepunched holes for splice plates

	Model no.	Height H		Width B		Weight per 100 pcs/kg	Pack/Box Qty
		mm	Inch	mm	Inch		
S	WSBR 150.200	150	5,9	200	7,9	983,71	1
S	WSBR 150.300	150	5,9	300	11,8	1.084,62	1
S	WSBR 150.400	150	5,9	400	15,7	1.185,53	1
S	WSBR 150.450	150	5,9	450	17,7	1.235,98	1
S	WSBR 150.500	150	5,9	500	19,7	1.286,44	1
S	WSBR 150.600	150	5,9	600	23,6	1.387,35	1
S	WSBR 150.750	150	5,9	750	29,5	2.090,83	1
S	WSBR 150.900	150	5,9	900	35,4	2.102,59	1
F	WSBR 150.200 F	150	5,9	200	7,9	1.082,08	1
F	WSBR 150.300 F	150	5,9	300	11,8	1.193,08	1
F	WSBR 150.400 F	150	5,9	400	15,7	1.304,08	1
F	WSBR 150.450 F	150	5,9	450	17,7	1.359,58	1
F	WSBR 150.500 F	150	5,9	500	19,7	1.415,08	1
F	WSBR 150.600 F	150	5,9	600	23,6	1.526,09	1
E3	WSBR 150.200 E3	150	5,9	200	7,9	990,00	1
E3	WSBR 150.300 E3	150	5,9	300	11,8	1.091,55	1
E3	WSBR 150.400 E3	150	5,9	400	15,7	1.193,10	1
E3	WSBR 150.500 E3	150	5,9	500	19,7	1.294,65	1
E3	WSBR 150.600 E3	150	5,9	600	23,6	1.396,20	1

WSV 150.500 splice plates have to be ordered separately.

Height 150 mm
Nominal 6 inches

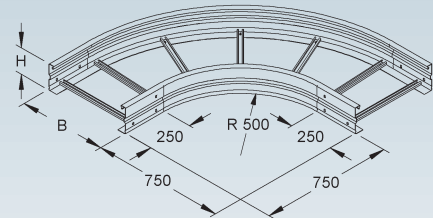

LONG SPAN CABLE LADDER

Horizontal Tee

with solid siderails but prepunched holes for splice plates

	Model no.	Height H		Width B		Weight per 100 pcs kg	Pack/Box Qty
		mm	Inch	mm	Inch		
S	WSTR 150.200	150	5,9	200	7,9	1.551,15	1
S	WSTR 150.300	150	5,9	300	11,8	1.657,20	1
S	WSTR 150.400	150	5,9	400	15,7	1.821,03	1
S	WSTR 150.450	150	5,9	450	17,7	1.881,41	1
S	WSTR 150.500	150	5,9	500	19,7	2.017,21	1
S	WSTR 150.600	150	5,9	600	23,6	2.145,48	1
S	WSTR 150.750	150	5,9	750	29,5	2.990,95	1
S	WSTR 150.900	150	5,9	900	35,4	3.477,52	1
F	WSTR 150.200 F	150	5,9	200	7,9	1.706,27	1
F	WSTR 150.300 F	150	5,9	300	11,8	1.822,92	1
F	WSTR 150.400 F	150	5,9	400	15,7	2.003,13	1
F	WSTR 150.450 F	150	5,9	450	17,7	2.069,55	1
F	WSTR 150.500 F	150	5,9	500	19,7	2.218,93	1
F	WSTR 150.600 F	150	5,9	600	23,6	2.360,03	1
E3	WSTR 150.200 E3	150	5,9	200	7,9	1.561,06	1
E3	WSTR 150.300 E3	150	5,9	300	11,8	1.667,78	1
E3	WSTR 150.400 E3	150	5,9	400	15,7	1.832,66	1
E3	WSTR 150.500 E3	150	5,9	500	19,7	2.030,09	1
E3	WSTR 150.600 E3	150	5,9	600	23,6	2.159,18	1

WSV 150.500 splice plates have to be ordered separately.

Height 150 mm
Nominal 6 inches

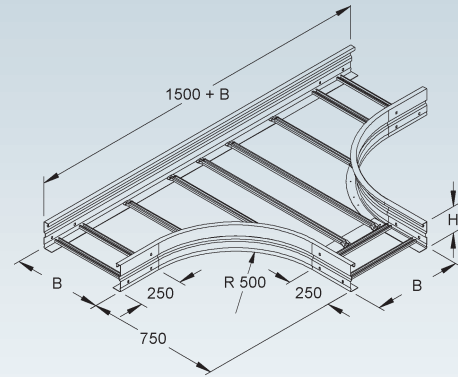

Reducer

	Model no.	Height H		Width B		Weight per 100 pcs kg	Pack/Box Qty
		mm	Inch	mm	Inch		
S	WSRS 150.100 S	150	5,9	100	3,9	53,61	1
S	WSRS 150.150 S	150	5,9	150	5,9	62,20	1
S	WSRS 150.200 S	150	5,9	200	7,9	70,80	1
S	WSRS 150.300 S	150	5,9	300	11,8	87,99	1

can be used as a reducer for long span cable trays and ladders

Height 150 mm
Nominal 6 inches



87

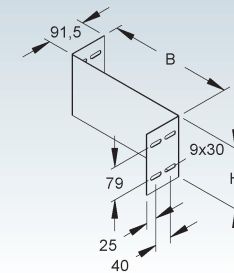

Endplate

	Model no.	Height H		Width B		Weight per 100 pcs kg	Pack/Box Qty
		mm	Inch	mm	Inch		
S	WSAS 150.200 S	150	5,9	200	7,9	71,30	1
S	WSAS 150.300 S	150	5,9	300	11,8	88,50	1
S	WSAS 150.400 S	150	5,9	400	15,7	105,69	1
S	WSAS 150.450 S	150	5,9	450	17,7	114,28	1
S	WSAS 150.500 S	150	5,9	500	19,7	122,88	1
S	WSAS 150.600 S	150	5,9	600	23,6	140,07	1
S	WSAS 150.750 S	150	5,9	750	29,5	165,86	1
S	WSAS 150.900 S	150	5,9	900	35,4	192,00	1

can be used as blind end or as reducer for long span cable trays and ladders

Height 150 mm
Nominal 6 inches



87

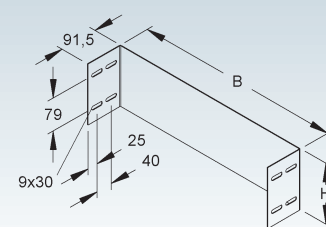

Wall/Floor and Cross Connector Bracket

for Long Span Ladder Trays

Model no.	Inside height H mm Inch	Thick-ness t mm	Acc. incl.	Weight per 100 pcs kg	Pack/Box Qty
S WHAS 150 S	151,5 6	2	4 FLM 8X13 F	90,76	10
E3 WHAS 150 E3	151,5 6	2	4 FLM 8X16 E3	91,72	10

for connecting horizontal and vertical runs of long span ladder trays of the same height as well as for wall, box and panel mount

Two pieces required for each connection



82

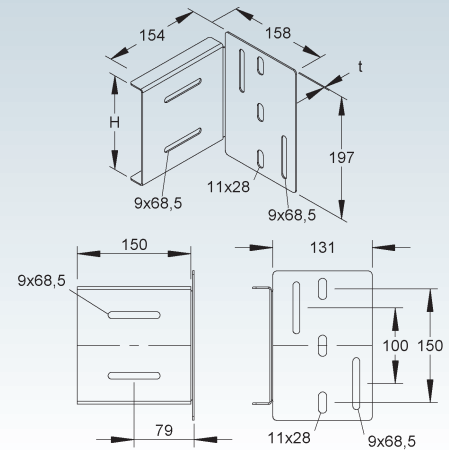

Pair of Protective End Caps

Model no.	Height H mm Inch	Color	Weight per 100 pair kg	Pack/Box Qty
K10 SKWHM 150	150 5,9	yellow	6	10 pair

Suitable for: long span cable ladder WSL 150... and WSLM 150...

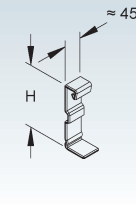
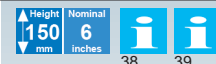

Ladder Drop Out

Model no.	Width B mm Inch	Acc. incl.	Weight per 100 pcs kg	Pack/Box Qty
S WLAB 200	190 7,5	2 FK 6X12 V, 2 GSM 406 G	37,14	1
S WLAB 300	290 11,4	2 FK 6X12 V, 2 GSM 406 G	59,89	1
S WLAB 400	390 15,4	2 FK 6X12 V, 2 GSM 406 G	82,64	1
S WLAB 500	490 19,3	2 FK 6X12 V, 2 GSM 406 G	138,31	1
S WLAB 600	590 23,2	2 FK 6X12 V, 2 GSM 406 G	168,36	1
F WLAB 200 F	190 7,5	2 FK 6X10 E3, 2 GSM 406 E3	40,44	1
F WLAB 300 F	290 11,4	2 FK 6X10 E3, 2 GSM 406 E3	65,46	1
F WLAB 400 F	390 15,4	2 FK 6X10 E3, 2 GSM 406 E3	90,49	1
F WLAB 500 F	490 19,3	2 FK 6X10 E3, 2 GSM 406 E3	151,71	1
F WLAB 600 F	590 23,2	2 FK 6X10 E3, 2 GSM 406 E3	184,77	1
E3 WLAB 200 E3	190 7,5	2 FK 6X10 E3, 2 GSM 406 E3	37,32	1
E3 WLAB 300 E3	290 11,4	2 FK 6X10 E3, 2 GSM 406 E3	60,22	1
E3 WLAB 400 E3	390 15,4	2 FK 6X10 E3, 2 GSM 406 E3	83,12	1
E3 WLAB 500 E3	490 19,3	2 FK 6X10 E3, 2 GSM 406 E3	139,13	1
E3 WLAB 600 E3	590 23,2	2 FK 6X10 E3, 2 GSM 406 E3	169,38	1

with rounded edges to protect cables at the drop out

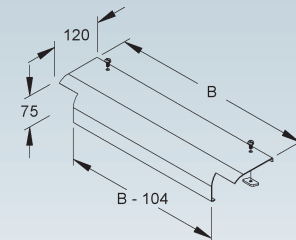

Mounting Clamp for Long Span Ladders

Model no.	Acc. incl.	Weight per 100 pcs kg	Pack/Box Qty
F WSTB 2	1 FLM 8X25 F	7,54	50
E3 WSTB 2 E3	1 FLDM 8X25 E3	7,56	50

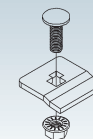

LONG SPAN CABLE LADDER

Mounting Clamp for Long Span Ladders

Model no.	Acc. incl.	Weight per 100 pcs kg	Pack/Box Qty
F WSTB 96 F	1 GMZF M8-22 F, 1 SK 8X25 F, 1 US M 8 F	10,36	50

2 pieces required per bracket

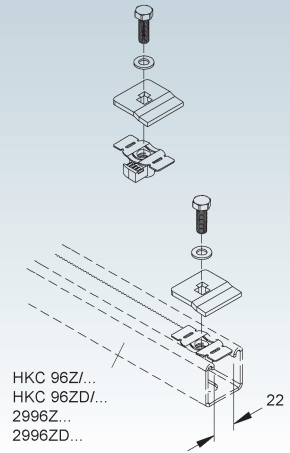

Two Hole Corner Angle

Model no.	Thick-ness t mm	Acc. incl.	Weight per 100 pcs kg	Pack/Box Qty
F WWU 150/8	5	1 FLM 8X16 F	19,11	50
E3 WWU 150/8 E3	4	1 FLM 8X16 E3	14,87	50

for floor-, ceiling- or wall-mounting

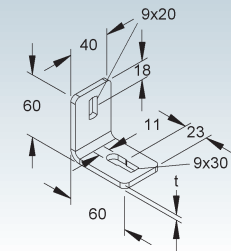

Two Hole Corner Angle

Model no.	Acc. incl.	Weight per 100 pcs kg	Pack/Box Qty
F WWU 150	1 FLM 10X25 F	21,03	50

for floor-, ceiling- or wall-mounting

Suitable for: U-profiles U 4530/..., U 5050/... and U 6040/...

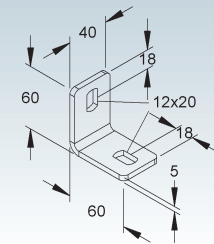

Three Hole Corner Angle

Model no.	Width B mm Inch	Thick-ness t mm	Acc. incl.	Weight per 100 pcs kg	Pack/Box Qty
F WWA 100	50,0 2	5	1 FLM 10X25 F	24,98	50
E3 WWA 100 E3	48,5 1,9	4	1 FLM 10X25 E3	19,09	50

for floor-, ceiling- or wall-mounting

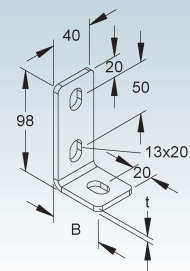

Cover for Long Span Cable Trays/Ladders

with turnbolt locks

	Model no.	Width B		Weight per 100 m kg	Pack/Box Qty
		mm	Inch		
S	WDV 200	204	8	150,90	2 x 3 m
S	WDV 300	304	12	251,77	2 x 3 m
S	WDV 400	404	15,9	358,51	2 x 3 m
S	WDV 450	454	17,9	398,02	2 x 3 m
S	WDV 500	504	19,8	437,54	2 x 3 m
S	WDV 600	604	23,8	516,57	2 x 3 m
S	WDV 750	754	29,7	946,70	2 x 3 m
S	WDV 900	904	35,6	1.123,33	2 x 3 m
F	WDV 200 F	204	8	165,99	2 x 3 m
F	WDV 300 F	304	12	276,95	2 x 3 m
F	WDV 400 F	404	15,9	394,36	2 x 3 m
F	WDV 450 F	454	17,9	437,83	2 x 3 m
F	WDV 500 F	504	19,8	481,29	2 x 3 m
F	WDV 600 F	604	23,8	568,23	2 x 3 m
E3	WDV 200 E3	204	8	162,33	2 x 3 m
E3	WDV 300 E3	304	12	253,87	2 x 3 m
E3	WDV 400 E3	404	15,9	361,29	2 x 3 m
E3	WDV 500 E3	504	19,8	440,82	2 x 3 m
E3	WDV 600 E3	604	23,8	520,36	2 x 3 m

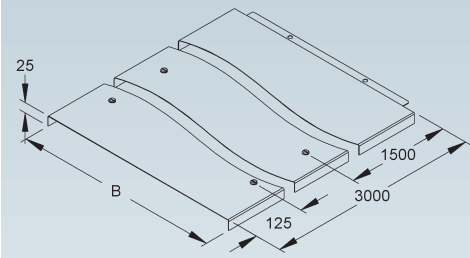

Suitable for: all long span cable trays WRL... as well as all long span cable ladders WSL.../WSLS...

For outdoor service covers need to be secured against wind loads using heavy duty cover clamps or steel cable ties.

Cover for 90° Horizontal Elbow

with turnbolt locks

	Model no.	Inside dimension B		Weight per 100 pcs kg	Pack/Box Qty
		mm	Inch		
S	WBRDV 200	204	8	245,01	1
S	WBRDV 300	304	12	376,38	1
S	WBRDV 400	404	15,9	520,08	1
S	WBRDV 450	454	17,9	596,55	1
S	WBRDV 500	504	19,8	676,11	1
S	WBRDV 600	604	23,8	844,47	1
S	WBRDV 750	754	29,7	1.140,29	1
S	WBRDV 900	904	35,6	1.423,52	1
F	WBRDV 200 F	204	8	269,43	1
F	WBRDV 300 F	304	12	413,94	1
F	WBRDV 400 F	404	15,9	572,00	1
F	WBRDV 450 F	454	17,9	656,21	1
F	WBRDV 500 F	504	19,8	743,64	1
F	WBRDV 600 F	604	23,8	928,83	1
E3	WBRDV 200 E3	204	8	248,81	1
E3	WBRDV 300 E3	304	12	381,01	1
E3	WBRDV 400 E3	404	15,9	525,63	1
E3	WBRDV 500 E3	504	19,8	682,65	1
E3	WBRDV 600 E3	604	23,8	852,08	1

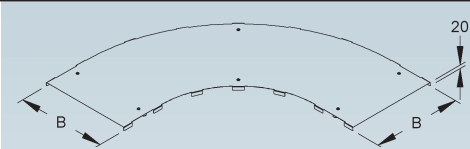

Suitable for: horizontal 90° long span elbows WRBR... and WSRB...

For outdoor service covers need to be secured against windloads using heavy duty cover clamps or steel cable ties.



LONG SPAN CABLE LADDER ACCESSORIES

Cover for Horizontal Extension Tee

with turnbolt locks

	Model no.	Inside dimension B mm Inch	Weight per 100 pcs kg	Pack/Box Qty
S	WTARDV 200	212,5 8,4	258,73	1
S	WTARDV 300	312,5 12,3	319,88	1
S	WTARDV 400	412,5 16,2	381,03	1
S	WTARDV 450	462,5 18,2	411,61	1
S	WTARDV 500	512,5 20,2	442,18	1
S	WTARDV 600	612,5 24,1	503,34	1
S	WTARDV 750	762,5 30	595,06	1
S	WTARDV 900	912,5 35,9	686,79	1
F	WTARDV 200 F	212,5 8,4	296,17	1
F	WTARDV 300 F	312,5 12,3	363,44	1
F	WTARDV 400 F	412,5 16,2	430,71	1
F	WTARDV 450 F	462,5 18,2	454,42	1
F	WTARDV 500 F	512,5 20,2	497,97	1
F	WTARDV 600 F	612,5 24,1	565,24	1
E3	WTARDV 200 E3	212,5 8,4	261,85	1
E3	WTARDV 300 E3	312,5 12,3	323,39	1
E3	WTARDV 400 E3	412,5 16,2	384,93	1
E3	WTARDV 500 E3	512,5 20,2	446,47	1
E3	WTARDV 600 E3	612,5 24,1	508,01	1

Suitable for: long span extension tee fittings WRTAR... and WSTAR...

For outdoor service covers need to be secured against windloads using heavy duty cover clamps or steel cable ties.

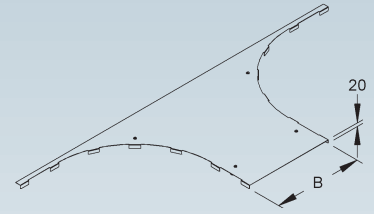

Cover for Horizontal Tee

with turnbolt locks

	Model no.	Inside dimension B mm Inch	Weight per 100 pcs kg	Pack/Box Qty
S	WTRDV 200	204 8	514,69	1
S	WTRDV 300	304 12	732,24	1
S	WTRDV 400	404 15,9	965,50	1
S	WTRDV 450	454 17,9	1.088,01	1
S	WTRDV 500	504 19,8	1.214,45	1
S	WTRDV 600	604 23,8	1.479,10	1
S	WTRDV 750	754 29,7	1.928,48	1
F	WTRDV 200 F	204 8	566,08	1
F	WTRDV 300 F	304 12	805,38	1
F	WTRDV 400 F	404 15,9	1.061,93	1
F	WTRDV 450 F	454 17,9	1.196,81	1
F	WTRDV 500 F	504 19,8	1.335,81	1
F	WTRDV 600 F	604 23,8	1.626,92	1
E3	WTRDV 200 E3	204 8	520,20	1
E3	WTRDV 300 E3	304 12	739,14	1
E3	WTRDV 400 E3	404 15,9	973,88	1
E3	WTRDV 500 E3	504 19,8	1.224,42	1
E3	WTRDV 600 E3	604 23,8	1.490,75	1

Suitable for: long span tee fittings WRTR... and WSTR...

For outdoor service covers need to be secured against windloads using heavy duty cover clamps or steel cable ties.

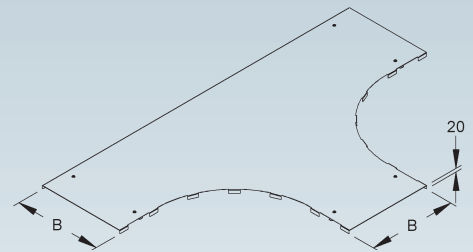

Turnbolt Lock

incl. locking nut

Model no.	Acc. incl.	Weight per 100 pcs kg	Pack/Box Qty
S WDRS 20	1 FL 6X12-S V, 1 SMS 6 V	2,25	50
F WDRS 20 F	1 FL 6X12-S E3, 1 SMS 6 E3	2,64	50
E3 WDRS 20 E3	1 FL 6X12-S E3, 1 SMS 6 E3	2,53	50

for field installation

Please maintain a 50 mm minimum distance from the edge of the cover for the turn-bolt installation.

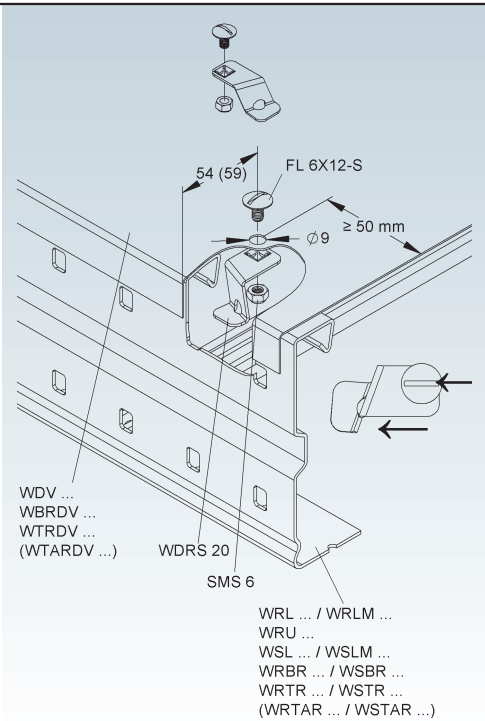

Raised Cover Clamp

spacer block with hold down bracket

Model no.	Height H mm Inch	Width B mm Inch	Thickness t mm	Acc. incl.	Weight per 100 pcs kg	Pack/Box Qty
S RDAH 30 S	122,5 4,8	40 1,6	1,5	2 FLM 6X12, 2 FLM 8X16 F	16,32	10
E3 RDAH 30 E3	122,5 4,8	40 1,6	1,5	2 FLM 6X12 E3, 2 FLM 8X16 E3	16,22	10

to elevate RD- and WDV-series covers for improved ventilation can be installed on all R-Series cable trays and all KL/WSL/WRL-series cable ladders with a minimum side rail height of 50 mm

Three pairs required for every 3-meter section of covers.

Suitable for: ventilated RL/RS cable trays, KL ladders, and WRL/WSL cable trays & ladders

Six cover clamps are required for any 3-meter piece of cover.

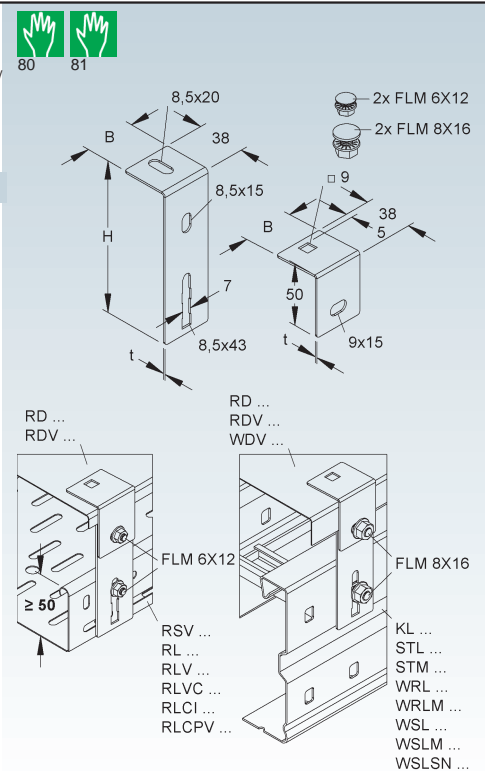

LONG SPAN CABLE LADDER ACCESSORIES

Turnbolt Lock

incl. locking nut

Model no.	Acc. incl.	Weight per 100 pcs kg	Pack/Box Qty
S RDRS 2	1 FL 6X12-S V, 1 SMS 6 V	1,3	100
E3 RDRS 2 E3	1 FL 6X12-S E3, 1 SMS 6 E3	1,5	100

Suitable for: all R-series fitting covers and RSV 50.100 distribution tray covers

Please maintain a 50 mm minimum distance from the edge of the cover for the turn-bolt installation. Not sufficient for securing covers to tray installed vertically or sideways nor for securing covers against windloads. Please use self tapping screws, steel cable ties or coverhinges in addition.

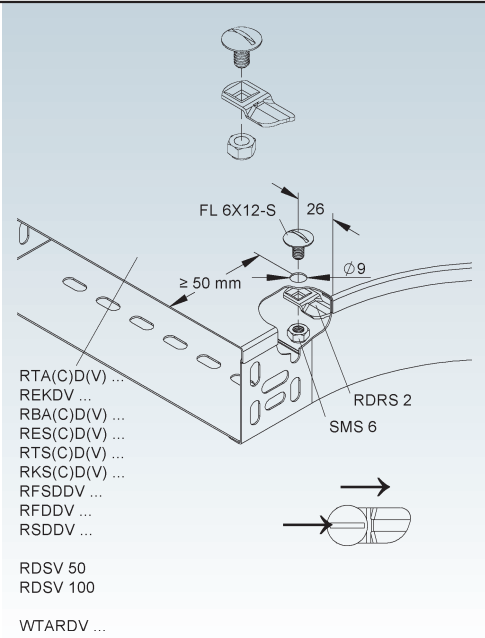

Protective End Cap

Model no.	Height H mm Inch	Color	Weight per 100 pcs kg	Pack/Box Qty
K04 SKSP 70	15 0,6	grey	0,57	20

Suitable for: framing channel 2970... and SP 70 rungs

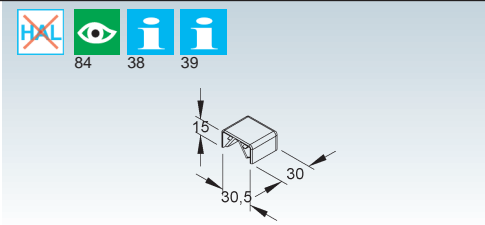

NOTES

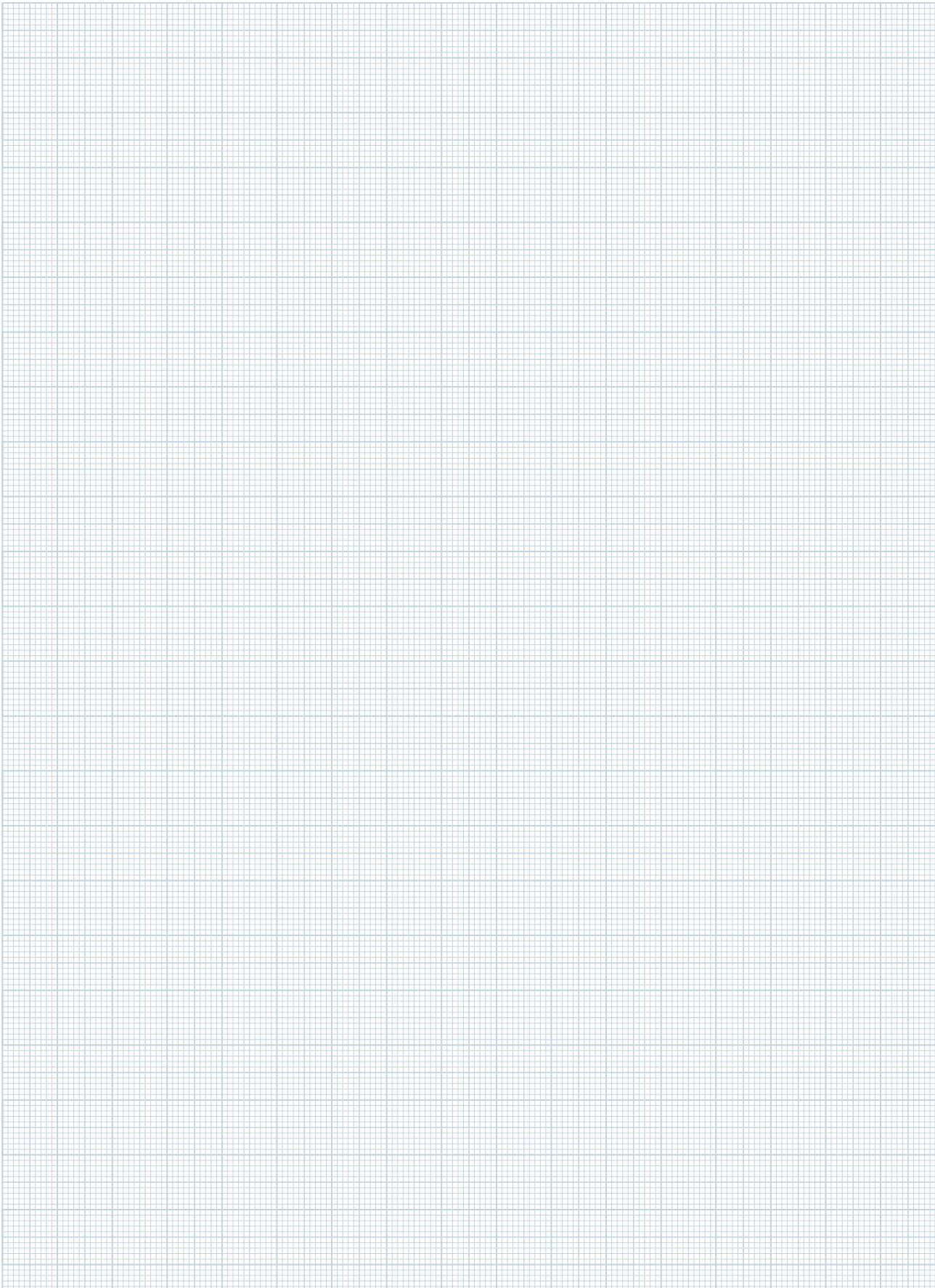

CABLE TRAY SYSTEM

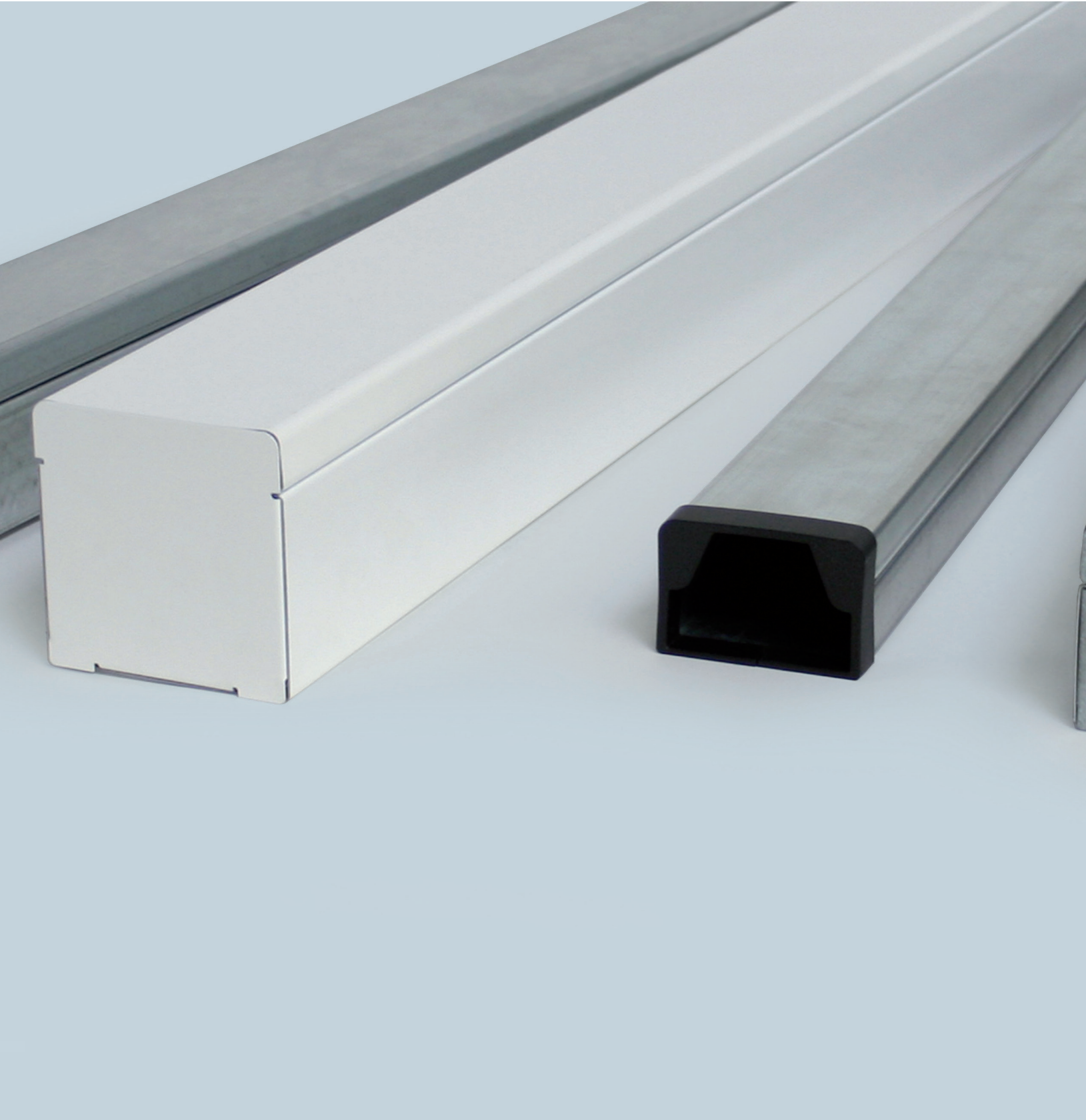

A close-up photograph of a grey metal channel cable tray, showing its U-shaped profile and perforated side panel. The tray is positioned diagonally across the left side of the page.

CHANNEL CABLE TRAY

- Channel Cable Tray
- Accessories
- Fittings

Niedax channel cable trays are designed for routing low voltage power circuits, data network and control cables in commercial, institutional and industrial applications. The system consists of a base section with a snap-on cover, dividers and a wide range of fittings. It's easy to install, expand and reconfigure. Direct wall mount is permitted. Various finishes are available.



CHANNEL CABLE TRAY

Available Side Rail Heights

Height 16 mm	Nominal 5/8 inches	Height 26 mm	Nominal 1 inches	Height 40 mm	Nominal 1 5/8 inches	Height 60 mm	Nominal 2 3/8 inches	Height 80 mm	Nominal 3 inches	Height 100 mm	Nominal 4 inches
--------------------	--------------------------	--------------------	------------------------	--------------------	----------------------------	--------------------	----------------------------	--------------------	------------------------	---------------------	------------------------

SYSTEM			
	Channel Cable Tray	LLK...	Page 327/329
	Channel Cable Tray	LUK...	Page 330
ACCESSORIES	Splice Plate	LST...	Page 328/330
	End-Cap	LED...	Page 328/334
	End-Protection Ring	LER...	Page 328/335
	Mounting Plate for Divider	TPH...	Page 330
	Mounting Plate for Divider	LZTP...	Page 330
	Divider	TPS...	Page 331
	Outside Elbow 45°	LUAB...	Page 331
	Inside Elbow 45°	LUIB...	Page 331
	Elbow 45°	LUWB...	Page 331
	Outside Elbow 90°	LUAC...	Page 332
	Outside Wide Radius Elbow (2x45°)	LUAD...	Page 332
	Inside Elbow 90°	LUIC...	Page 332
	Wide Radius Elbow (2x45°)	LUID...	Page 332
	Elbow 90°	LUWC...	Page 333
	Wide Radius Elbow (2x45°)	LUWD...	Page 333
	Wide Radius Tee	LUTC...	Page 333
	Horizontal Tee	LUT...	Page 334
	Cable Retainer Clamp	LHS...	Page 335
	End-Protection Ring	LES...	Page 335



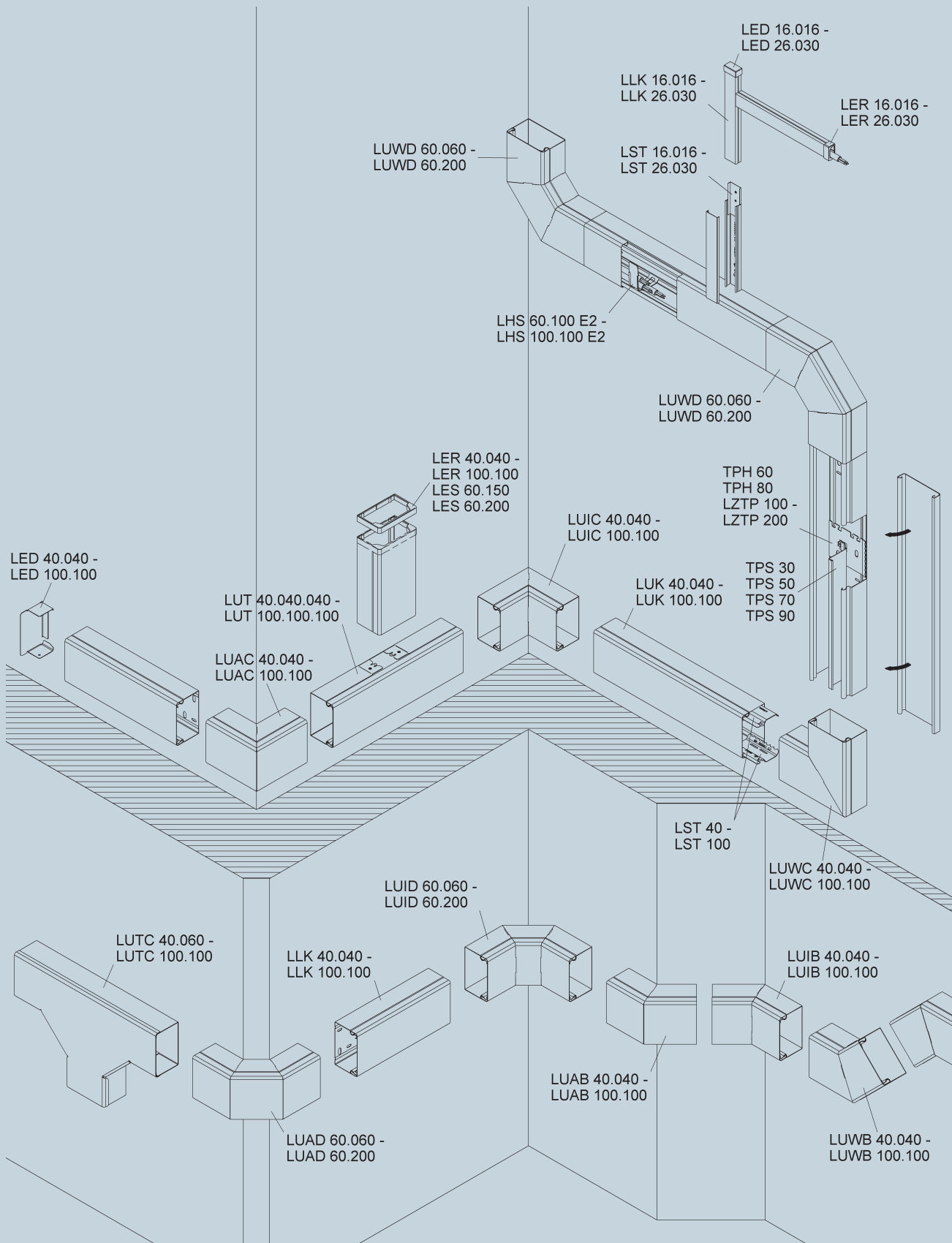

CHANNEL CABLE TRAY

Channel Cable Tray Specifications:

A. CABLE TRAY DESIGN

1. Channel Cable Tray shall be made of straight sections, fittings and accessories as defined in the latest NEMA standards per NEMA VE-1. Standard cable trays shall be UL classified as equipment grounding conductors.

B. MATERIAL

1. **Pre-galvanized steel.** The structural quality of the steel shall meet the minimum yield and tensile strength of the ASTM standards (ASTM A 653) with G 90 coating thickness. All cable trays to be labeled for material identification purposes.
2. **Powder coated pre-galvanized steel.** All trays to be made from pre-galvanized steel and powder coated after fabrication. All trays to be labeled for material identification.
3. **Stainless steel.** All trays are to be constructed of AISI type 304 or type 316 stainless steel. All trays to be labeled for material identification.

C. TRAY TYPES

1. **Solid channel cable tray.** Trays are to be fabricated from continuous roll-formed structural quality steel. Sides are to be solid as well as bottom for maximum cable enclosure and support.
2. **Solid channel cable tray with mounting holes.** Trays are to be fabricated from continuous roll-formed structural quality steel. Sides are to be solid, bottom has predrilled mounting holes for easy installation.

D. TRAY SIZE

1. **Height:** Trays shall have an overall height of 1", 1.5", 2.3", 3.1", and 4" (26, 40, 60, 80 and 100 mm). Loading depth is the same as the overall height, as there are no rungs to reduce the fill of the tray.
2. **Width:** Widths shall be 1", 1.5", 2.3", 3.1", 4", 6", and 8" (30, 40, 60, 80, 100, 150 and 200 mm).
3. **Length:** Length shall be a nominal 6.6' or 2 meters.

E. ACCESSORIES

1. **Covers.** Covers to protect tray cable shall be supplied automatically with every piece of channel tray and every fitting.
2. **Splice plates.** Splice plates have to be ordered separately for all straight sections and fittings.
3. **Other accessories** shall be furnished as required to protect, support, and install a cable tray system. Fittings shall be made of the same material as the cable tray whenever possible. Fittings can be of factory construction or may also be of a type that allows field constructed fittings.

F. LOADING CAPABILITIES

1. Channel cable tray shall meet the load/span class designation in accordance with NEMA VE 1 and CSA C22.2 No 126.1. Cable tray shall also meet load/span designation in accordance with IEC 61537.

G. DESIGN AND MANUFACTURE

1. Cable tray design shall be manufactured by The Niedax Group, series LLK and LUK.

Channel Cable Tray

cover included

	Model no.	Height H		Width B		Weight per 100 m kg	Pack/Box Qty
		mm	Inch	mm	Inch		
S	LLK 16.016	16	0,6	16	0,6	31,33	48 x 2 m
S	LLK 16.030	16	0,6	30	1,2	42,31	30 x 2 m

Please use LST... snapin splice plates for proper mechanical and electrical connections.
Splice plates have to be ordered separately.

Height	Nominal	Height	Nominal	
16 mm	5/8 inches	26 mm	1 inches	

88

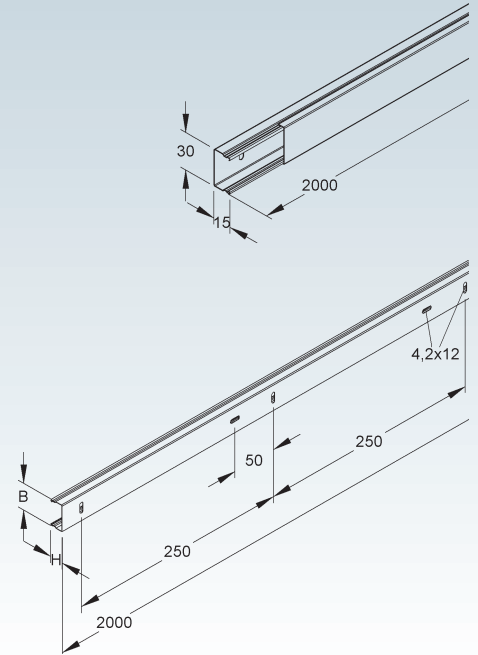

Channel Cable Tray

cover included

	Model no.	Height H		Width B		Weight per 100 m kg	Pack/Box Qty
		mm	Inch	mm	Inch		
S	LLK 26.030	26	1	30	1,2	50,02	18 x 2 m

Please use LST... snapin splice plates for proper mechanical and electrical connections.
Splice plates have to be ordered separately.

Height	Nominal	
26 mm	1 inches	

88

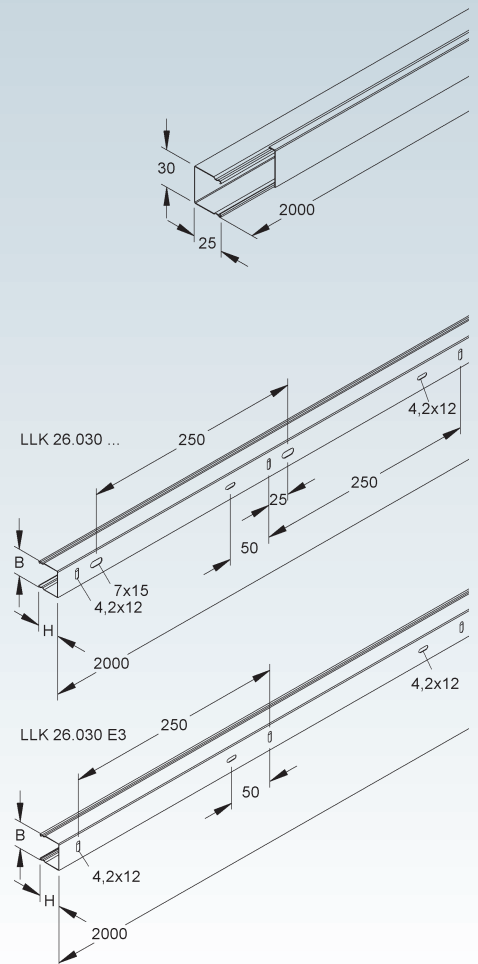

CHANNEL CABLE TRAY

Splice Plate

Model no.	Length L mm Inch	Weight per 100 pcs kg	Pack/ Box Qty
MS LST 16.016	74 2,9	0,62	20
MS LST 16.030	74 2,9	0,99	20
MS LST 26.030	74 2,9	1,30	20

mechanical splice and electrical connector for raceways

1 piece required per joint

Height 16 mm	Nominal 5/8 inches	Height 26 mm	Nominal 1 inches
--------------------	--------------------------	--------------------	------------------------

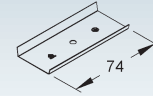

End-Cap

Model no.	Height H mm Inch	Width B mm Inch	Color	Weight per 100 pcs kg	Pack/ Box Qty
K04 LED 16.016	16 0,6	16 0,6	black	0,10	20
K04 LED 16.030	16 0,6	30 1,2	black	0,18	20
K04 LED 26.030	26 1	30 1,2	black	0,23	20

Height 16 mm	Nominal 5/8 inches	Height 26 mm	Nominal 1 inches				
						38	39

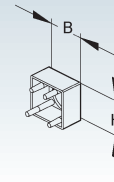

End-Protection Ring

Model no.	Height H mm Inch	Width B mm Inch	Similar to RAL	Weight per 100 pcs kg	Pack/ Box Qty
K04 LER 16.016	16 0,6	16 0,6	7021	0,15	20
K04 LER 16.030	16 0,6	30 1,2	7021	0,21	20
K04 LER 26.030	26 1	30 1,2	7021	0,27	20

contains no silicone

End caps LER... can be attached to the channel cable tray after installation.

Height 16 mm	Nominal 5/8 inches	Height 26 mm	Nominal 1 inches				
						38	39

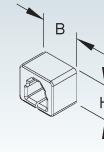

Channel Cable Tray

with perforated bottom, cover included

	Model no.	Height H		Width B		Weight per 100 m kg	Pack/Box Qty
		mm	Inch	mm	Inch		
S	LLK 40.040	40	1,6	40	1,6	95,18	12 x 2 m
S	LLK 40.060	40	1,6	60	2,4	132,36	6 x 2 m
S	LLK 60.060	60	2,4	60	2,4	174,76	6 x 2 m

Hole pattern may vary based on width of tray.

Please use LST... snapin splice plates for proper mechanical and electrical connections.

Height	Nominal	Height	Nominal	
40	1 5/8	60	2 3/8	
mm	inches	mm	inches	88

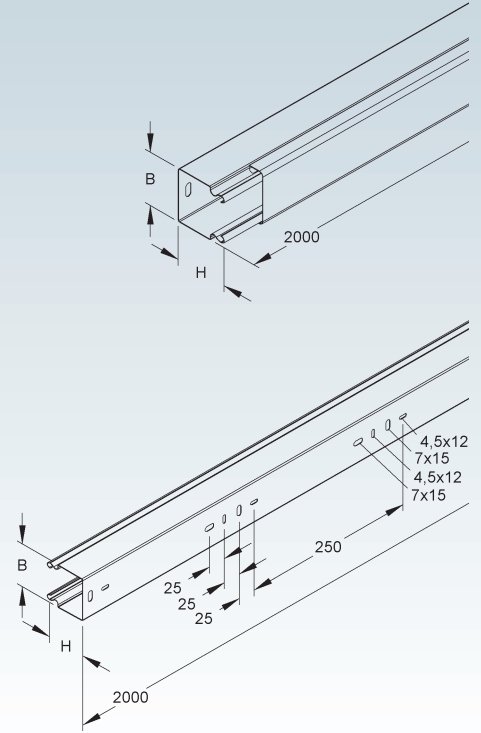

Channel Cable Tray

with perforated bottom, cover included

	Model no.	Height H		Width B		Distance between drilling holes A mm	Weight per 100 m kg	Pack/Box Qty
		mm	Inch	mm	Inch			
S	LLK 60.100	60	2,4	100	3,9	50	235,04	4 x 2 m
S	LLK 60.150	60	2,4	150	5,9	100	351,30	2 x 2 m
S	LLK 60.200	60	2,4	200	7,9	150	421,95	2 x 2 m
S	LLK 80.080	80	3,1	80	3,1	30	233,90	4 x 2 m
S	LLK 100.100	100	3,9	100	3,9	50	319,60	4 x 2 m

Hole pattern may vary based on width of tray.

Please use LST... snapin splice plates for proper mechanical and electrical connections.

Height	Nominal	Height	Nominal	Height	Nominal	
60	2 3/8	80	3	100	4	
mm	inches	mm	inches	mm	inches	88

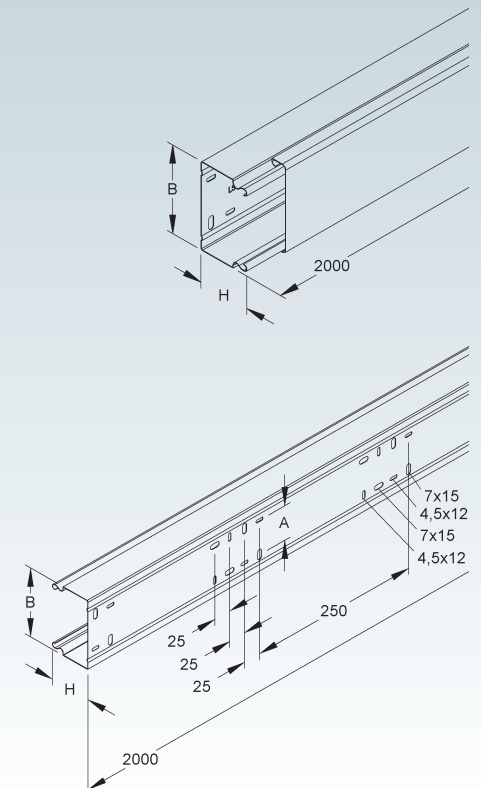

CHANNEL CABLE TRAY

Channel Cable Tray

solid bottom, including cover

	Model no.	Height H		Width B		Weight per 100 m kg	Pack/Box Qty
		mm	Inch	mm	Inch		
S	LUK 40.040	40	1,6	40	1,6	95,59	12 x 2 m
S	LUK 40.060	40	1,6	60	2,4	132,89	6 x 2 m
S	LUK 60.060	60	2,4	60	2,4	175,45	6 x 2 m
S	LUK 60.100	60	2,4	100	3,9	236,48	4 x 2 m
S	LUK 60.150	60	2,4	150	5,9	352,97	2 x 2 m
S	LUK 60.200	60	2,4	200	7,9	423,71	2 x 2 m
S	LUK 80.080	79	3,1	80	3,1	235,35	4 x 2 m
S	LUK 100.100	100	3,9	100	3,9	321,25	4 x 2 m

Please use LST... snapin splice plates for proper mechanical and electrical connections.

Height 40 mm	Nominal 1 5/8 inches	Height 60 mm	Nominal 2 3/8 inches	Height 80 mm	Nominal 3 inches	Height 100 mm	Nominal 4 inches	
--------------------	----------------------------	--------------------	----------------------------	--------------------	------------------------	---------------------	------------------------	--

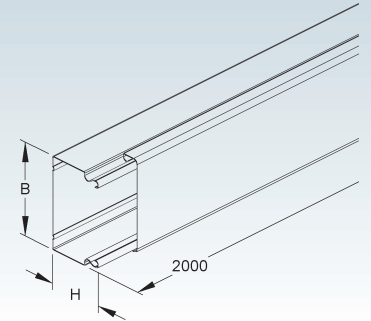

Splice Plate

with flat contact pin (6,3 mm) for protective grounding

	Model no.	Height H		Weight per 100 pcs kg	Pack/Box Qty
		mm	Inch		
S	LST 40	40	1,6	1,77	20
S	LST 60	60	2,4	2,71	20
S	LST 80	80	3,1	3,61	20
S	LST 100	100	3,9	4,63	20

mechanical splice and electrical connector for channel cable tray

2 pieces required per joint

Height 40 mm	Nominal 1 5/8 inches	Height 60 mm	Nominal 2 3/8 inches	Height 80 mm	Nominal 3 inches	Height 100 mm	Nominal 4 inches	
--------------------	----------------------------	--------------------	----------------------------	--------------------	------------------------	---------------------	------------------------	--

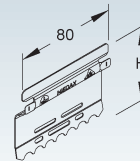

Mounting Plate for Divider

	Model no.	Depth T	Dist. A	Weight per 100 pcs kg	Pack/Box Qty
		mm			
S	TPH 60	59	30 1,2	3,44	20
S	TPH 80	79	37 1,5	4,58	20

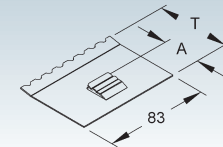

Mounting Plate for Divider

with strain relief

	Model no.	Depth T	Weight per 100 pcs kg	Pack/Box Qty
		mm		
S	LZTP 100	99	5,48	20
S	LZTP 150	149	8,29	20
S	LZTP 200	199	11,10	20

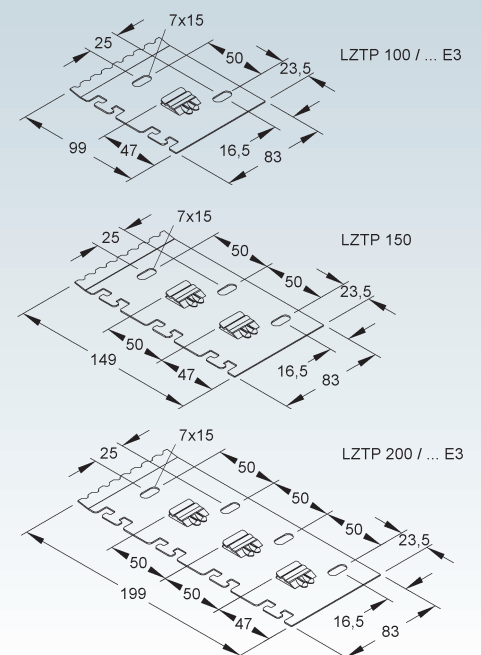

Divider

	Model no.	Height H		Depth T	Weight per 100 m kg	Pack/Box Qty
		mm	Inch			
S	TPS 30	11	0,4	30	36,51	10 x 2 m
S	TPS 50	11	0,4	50	48,26	10 x 2 m
S	TPS 70	11	0,4	70	60,01	10 x 2 m
S	TPS 90	11	0,4	90	71,76	10 x 2 m

to separate wires and cables of different voltage levels or with different functions

Suitable for: channel cable tray LLK... and LUK...

Height	Nominal	Height	Nominal	Height	Nominal	Height	Nominal
mm	inches	mm	inches	mm	inches	mm	inches
30	1 1/8	50	2	70	2 3/4	90	3 1/2

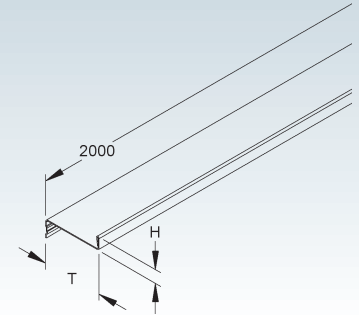

Outside Elbow 45°

cover included

	Model no.	Height H		Width B		Weight per 100 pcs kg	Pack/Box Qty
		mm	Inch	mm	Inch		
S	LUAB 40.040	40	1,6	40	1,6	17,96	8
S	LUAB 40.060	40	1,6	60	2,4	25,31	8
S	LUAB 60.060	60	2,4	60	2,4	35,61	8
S	LUAB 60.100	60	2,4	100	3,9	45,61	8
S	LUAB 60.150	60	2,4	150	5,9	63,83	4
S	LUAB 60.200	60	2,4	200	7,9	76,82	4
S	LUAB 80.080	80	3,1	80	3,1	46,28	4
S	LUAB 100.100	100	3,9	100	3,9	67,99	4

Please use LST... snapin splice plates for proper mechanical and electrical connections.

Splice plates have to be ordered separately.

Height	Nominal	Height	Nominal	Height	Nominal	Height	Nominal
mm	inches	mm	inches	mm	inches	mm	inches
40	1 5/8	60	2 3/8	80	3	100	4

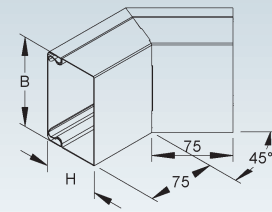

Inside Elbow 45°

cover included

	Model no.	Height H		Width B		Weight per 100 pcs kg	Pack/Box Qty
		mm	Inch	mm	Inch		
S	LUIB 40.040	40	1,6	40	1,6	16,65	8
S	LUIB 40.060	40	1,6	60	2,4	23,42	8
S	LUIB 60.060	60	2,4	60	2,4	32,89	8
S	LUIB 60.100	60	2,4	100	3,9	41,19	8
S	LUIB 60.150	60	2,4	150	5,9	61,84	4
S	LUIB 60.200	60	2,4	200	7,9	74,45	4
S	LUIB 80.080	80	3,1	80	3,1	42,98	8
S	LUIB 100.100	100	3,9	100	3,9	61,38	4

Please use LST... snapin splice plates for proper mechanical and electrical connections.

Splice plates have to be ordered separately.

Height	Nominal	Height	Nominal	Height	Nominal	Height	Nominal
mm	inches	mm	inches	mm	inches	mm	inches
40	1 5/8	60	2 3/8	80	3	100	4

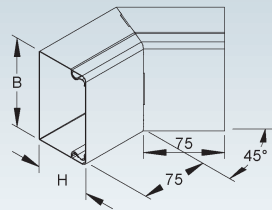

Elbow 45°

cover included

	Model no.	Height H		Width B		Weight per 100 pcs kg	Pack/Box Qty
		mm	Inch	mm	Inch		
S	LUWB 40.040	40	1,6	40	1,6	16,87	8
S	LUWB 40.060	40	1,6	60	2,4	25,24	8
S	LUWB 60.060	60	2,4	60	2,4	33,97	8
S	LUWB 60.100	60	2,4	100	3,9	46,20	8
S	LUWB 60.150	60	2,4	150	5,9	76,66	4
S	LUWB 60.200	60	2,4	200	7,9	101,32	4
S	LUWB 80.080	80	3,1	80	3,1	44,06	8
S	LUWB 100.100	100	3,9	100	3,9	63,47	4

Please use LST... snapin splice plates for proper mechanical and electrical connections.

Splice plates have to be ordered separately.

Height	Nominal	Height	Nominal	Height	Nominal	Height	Nominal
mm	inches	mm	inches	mm	inches	mm	inches
40	1 5/8	60	2 3/8	80	3	100	4

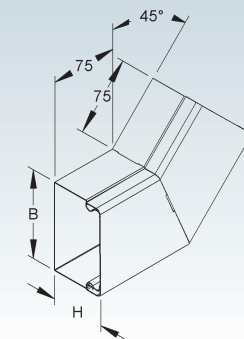

CHANNEL CABLE TRAY

Outside Elbow 90°

cover included

	Model no.	Height H		Width B		Weight per 100 pcs kg	Pack/Box Qty
		mm	Inch	mm	Inch		
S	LUAC 40.040	40	1,6	40	1,6	22,39	8
S	LUAC 40.060	40	1,6	60	2,4	31,23	8
S	LUAC 60.060	60	2,4	60	2,4	42,98	8
S	LUAC 60.100	60	2,4	100	3,9	54,63	8
S	LUAC 60.150	60	2,4	150	5,9	77,54	4
S	LUAC 60.200	60	2,4	200	7,9	93,17	4
S	LUAC 80.080	80	3,1	80	3,1	58,70	8
S	LUAC 100.100	100	3,9	100	3,9	90,14	4

Please use LST... snapin splice plates for proper mechanical and electrical connections.
Splice plates have to be ordered separately.

Height	Nominal	Height	Nominal	Height	Nominal	Height	Nominal
40	1 5/8	60	2 3/8	80	3	100	4
mm	inches	mm	inches	mm	inches	mm	inches

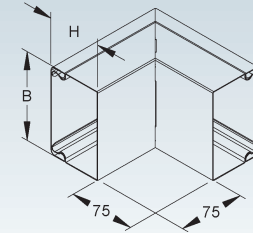

Outside Wide Radius Elbow (2x45°)

cover included

	Model no.	Height H		Width B		Weight per 100 pcs kg	Pack/Box Qty
		mm	Inch	mm	Inch		
S	LUAD 60.060	60	2,4	60	2,4	52,29	1
S	LUAD 60.100	60	2,4	100	3,9	67,06	1
S	LUAD 60.200	60	2,4	200	7,9	111,18	1

Please use LST... snapin splice plates for proper mechanical and electrical connections.
Splice plates have to be ordered separately.

Height	Nominal
60	2 3/8
mm	inches

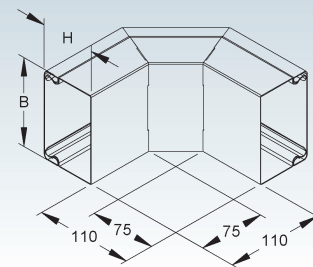

Inside Elbow 90°

cover included

	Model no.	Height H		Width B		Weight per 100 pcs kg	Pack/Box Qty
		mm	Inch	mm	Inch		
S	LUIC 40.040	40	1,6	40	1,6	19,39	8
S	LUIC 40.060	40	1,6	60	2,4	26,51	8
S	LUIC 60.060	60	2,4	60	2,4	38,61	8
S	LUIC 60.100	60	2,4	100	3,9	48,59	8
S	LUIC 60.150	60	2,4	150	5,9	73,86	4
S	LUIC 60.200	60	2,4	200	7,9	89,28	4
S	LUIC 80.080	80	3,1	80	3,1	52,56	8
S	LUIC 100.100	100	3,9	100	3,9	78,71	4

Please use LST... snapin splice plates for proper mechanical and electrical connections.
Splice plates have to be ordered separately.

Height	Nominal	Height	Nominal	Height	Nominal	Height	Nominal
40	1 5/8	60	2 3/8	80	3	100	4
mm	inches	mm	inches	mm	inches	mm	inches

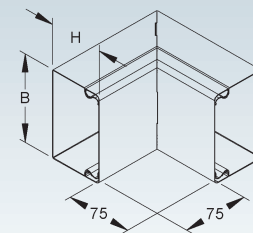

Wide Radius Elbow (2x45°)

cover included

	Model no.	Height H		Width B		Weight per 100 pcs kg	Pack/Box Qty
		mm	Inch	mm	Inch		
S	LUID 60.060	60	2,4	60	2,4	46,86	1
S	LUID 60.100	60	2,4	100	3,9	58,50	1
S	LUID 60.200	60	2,4	200	7,9	106,12	1

Please use LST... snapin splice plates have to be ordered separately

Height	Nominal
60	2 3/8
mm	inches

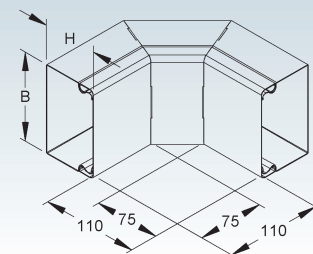

Elbow 90°

cover included

	Model no.	Height H		Width B		Weight per 100 pcs kg	Pack/Box Qty
		mm	Inch	mm	Inch		
S	LUWC 40.040	40	1,6	40	1,6	19,28	8
S	LUWC 40.060	40	1,6	60	2,4	30,11	8
S	LUWC 60.060	60	2,4	60	2,4	40,51	8
S	LUWC 60.100	60	2,4	100	3,9	59,75	8
S	LUWC 60.150	60	2,4	150	5,9	108,21	4
S	LUWC 60.200	60	2,4	200	7,9	151,63	4
S	LUWC 80.080	80	3,1	80	3,1	57,39	8
S	LUWC 100.100	100	3,9	100	3,9	83,72	4

Please use LST... snapin splice plates for proper mechanical and electrical connections.
Splice plates have to be ordered separately.

Height	Nominal	Height	Nominal	Height	Nominal	Height	Nominal
40	1 5/8	60	2 3/8	80	3	100	4
mm	inches	mm	inches	mm	inches	mm	inches

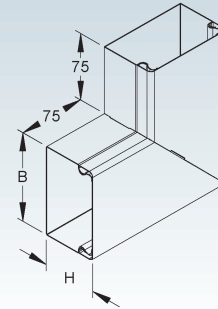

Wide Radius Elbow (2x45°)

	Model no.	Height H		Width B		Weight per 100 pcs kg	Pack/Box Qty
		mm	Inch	mm	Inch		
S	LUWD 60.060	60	2,4	60	2,4	48,62	1
S	LUWD 60.100	60	2,4	100	3,9	68,35	1
S	LUWD 60.200	60	2,4	200	7,9	160,18	1

Splice plates have to be ordered separately.

Height	Nominal
60	2 3/8
mm	inches

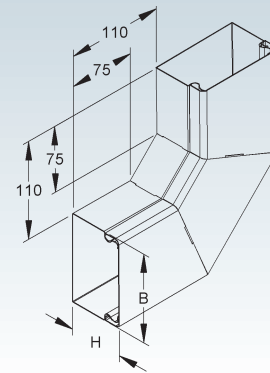

Wide Radius Tee

cover included

	Model no.	Height H		Width B		Weight per 100 pcs kg	Pack/Box Qty
		mm	Inch	mm	Inch		
S	LUTC 40.060	40	1,6	60	2,4	92,36	2
S	LUTC 60.060	60	2,4	60	2,4	106,50	2
S	LUTC 60.100	60	2,4	100	3,9	145,29	2
S	LUTC 60.150	60	2,4	150	5,9	200,84	1
S	LUTC 60.200	60	2,4	200	7,9	264,25	1
S	LUTC 80.080	80	3,1	80	3,1	206,97	1
S	LUTC 100.100	100	3,9	100	3,9	252,37	1

Size of run and tap tray must be identical.

Please use LST... snapin splice plates for proper mechanical and electrical connections.

Splice plates have to be ordered separately.

Height	Nominal	Height	Nominal	Height	Nominal	Height	Nominal
40	1 5/8	60	2 3/8	80	3	100	4
mm	inches	mm	inches	mm	inches	mm	inches

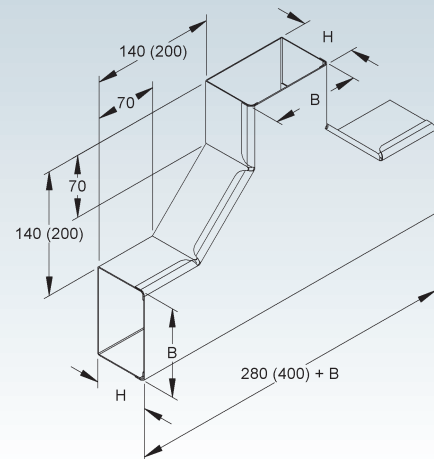

CHANNEL CABLE TRAY

Horizontal Tee

cover included

Model no.		Height H	Width B	Width of exit A	Weight per 100 pcs kg	Pack/ Box Qty
		mm Inch	mm Inch	mm		
S	LUT 40.040.040	40 1,6	40 1,6	40	33,52	2
S	LUT 40.060.040	40 1,6	60 2,4	40	46,65	2

H x B = height and width of the tee fitting
A = width of the 90° tee exit

Please use LST... snapin splice plates for proper mechanical and electrical connections.

Splice plates have to be ordered separately.

▲ Height
40
mm
▼
Nominal
1 5/8
inches

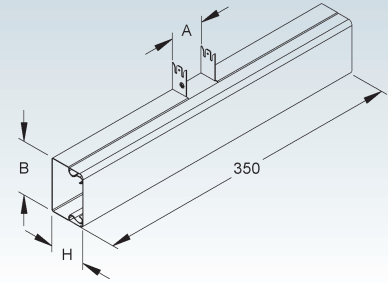

Horizontal Tee

cover included

Model no.		Height H	Width B	Width of exit A	Weight per 100 pcs kg	Pack/ Box Qty
		mm Inch	mm Inch	mm		
S	LUT 60.060.060	60 2,4	60 2,4	60	59,76	2
S	LUT 60.100.060	60 2,4	100 3,9	60	80,79	2
S	LUT 60.100.100	60 2,4	100 3,9	100	79,15	2
S	LUT 60.150.060	60 2,4	150 5,9	60	121,21	2
S	LUT 60.150.100	60 2,4	150 5,9	100	119,26	2
S	LUT 60.150.150	60 2,4	150 5,9	150	116,68	2
S	LUT 60.200.060	60 2,4	200 7,9	60	146,79	2
S	LUT 60.200.100	60 2,4	200 7,9	100	144,82	2
S	LUT 60.200.150	60 2,4	200 7,9	150	142,25	2
S	LUT 60.200.200	60 2,4	200 7,9	200	139,68	2
S	LUT 80.080.080	80 3,1	80 3,1	80	79,79	2
S	LUT 100.100.100	100 3,9	100 3,9	100	107,45	2

H x B = height and width of the tee fitting
A = width of the 90° tee exit

Please use LST... snapin splice plates for proper mechanical and electrical connections.

Splice plates have to be ordered separately.

▲ Height
60
mm
▼
Nominal
2 3/8
inches

▲ Height
80
mm
▼
Nominal
3
inches

▲ Height
100
mm
▼
Nominal
4
inches

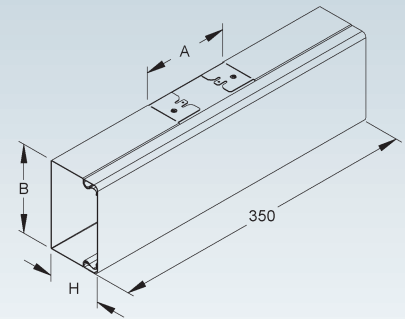

End-Cap

Model no.		Height H	Width B	Weight per 100 pcs kg	Pack/ Box Qty
		mm Inch	mm Inch		
S	LED 40.040	40 1,6	40 1,6	1,81	6
S	LED 40.060	40 1,6	60 2,4	2,47	6
S	LED 60.060	60 2,4	60 2,4	3,88	6
S	LED 60.100	60 2,4	100 3,9	5,62	6
S	LED 60.150	60 2,4	150 5,9	7,81	6
S	LED 60.200	60 2,4	200 7,9	9,99	6
S	LED 80.080	80 3,1	80 3,1	6,32	6
S	LED 100.100	100 3,9	100 3,9	9,40	6

▲ Height
40
mm
▼
Nominal
1 5/8
inches

▲ Height
60
mm
▼
Nominal
2 3/8
inches

▲ Height
80
mm
▼
Nominal
3
inches

▲ Height
100
mm
▼
Nominal
4
inches

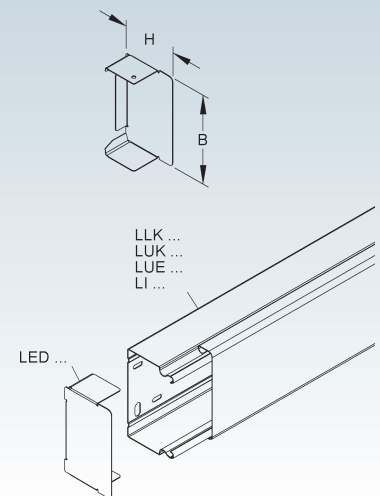

Cable Retainer Clamp

Model no.	Height H	Width B	Weight per 100 pcs kg	Pack/Box Qty
	mm Inch	mm Inch		
E2 LHS 60.100 E2	60 2,4	55 2,2	2,03	20
E2 LHS 60.150 E2	60 2,4	105 4,1	2,99	20
E2 LHS 60.200 E2	60 2,4	155 6,1	3,95	20
E2 LHS 80.080 E2	80 3,1	35 1,4	1,85	20
E2 LHS 100.100 E2	100 3,9	55 2,2	2,47	20

Height 60 mm	Nominal 2 3/8 inches	Height 80 mm	Nominal 3 inches	Height 100 mm	Nominal 4 inches	
-----------------	-------------------------	-----------------	---------------------	------------------	---------------------	---

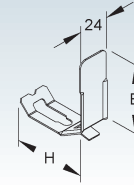

End-Protection Ring

Model no.	Height H	Width B	Similar to RAL	Weight per 100 pcs kg	Pack/Box Qty
	mm Inch	mm Inch			
K04 LER 40.040	40 1,6	40 1,6	7021	0,33	10
K04 LER 40.060	40 1,6	60 2,4	7021	0,40	10
K04 LER 60.060	60 2,4	60 2,4	7021	0,49	10
K04 LER 60.100	60 2,4	100 3,9	7021	0,65	10
K04 LER 80.080	80 3,1	80 3,1	7021	1,23	10
K04 LER 100.100	100 3,9	100 3,9	7021	1,54	10

contains no silicone

End caps LER... can be attached to the channel cable tray after installation.

Height 40 mm	Nominal 1 5/8 inches	Height 60 mm	Nominal 2 3/8 inches	Height 80 mm	Nominal 3 inches	Height 100 mm	Nominal 4 inches
-----------------	-------------------------	-----------------	-------------------------	-----------------	---------------------	------------------	---------------------

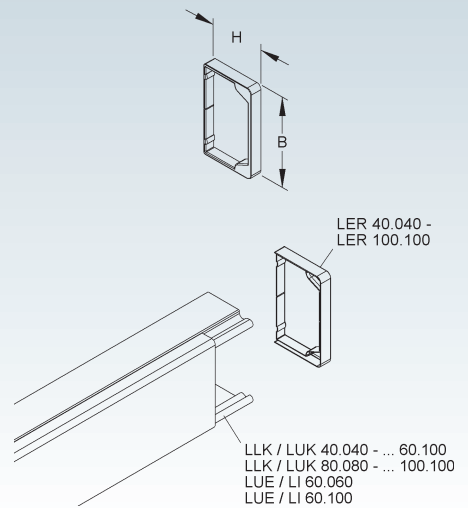

End-Protection Ring

Model no.	Height H	Width B	Color	Weight per 100 pcs kg	Pack/Box Qty
	mm Inch	mm Inch			
K10 LES 60.150	60 2,4	150 5,9	black	4,71	10
K10 LES 60.200	60 2,4	200 7,9	black	5,85	10

Height 60 mm	Nominal 2 3/8 inches				
-----------------	-------------------------	---	---	---	---

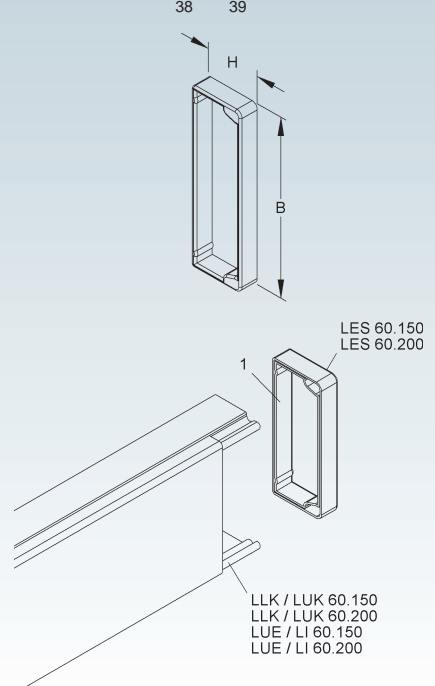

SURFACE METAL RACEWAY

Available Side Rail Heights

SYSTEM	Channel Cable Tray	LLKX 100.100 E3	Page 338
ACCESSORIES	Splice Plate	LSTX 100 E3	Page 338
	Mounting Plate for Divider	LZTP 100 E3	Page 339
	Divider	TPSX 90 E3	Page 339
	Outside Elbow 45°	LUABX 100.100 E3	Page 339
	Inside Elbow 45°	LUIBX 100.100 E3	Page 339
	Elbow 45°	LUW BX 100.100 E3	Page 340
	Outside Wide Radius Elbow (2x45°)	LUADX 100.100 E3	Page 340
	Wide Radius Elbow (2x45°)	LUIDX 100.100 E3	Page 340
	Wide Radius Elbow (2x45°)	LUWDX 100.100 E3	Page 340
	Wide Radius Tee	LUTCX 100.100 E3	Page 341
	End-Cap	LEDX 100.100 E3	Page 341
	Cable Retainer Clamp	LHS 100.100 E2	Page 341
	End-Protection Ring	LER 100.100	Page 342



SURFACE METAL RACEWAY

Channel Cable Tray

with perforated bottom, cover included

Model no.	Height H		Width B		Distance between drilling holes A mm	Weight per 100 m kg	Pack/Box Qty
	mm	Inch	mm	Inch			
E3 LLKX 100.100 E3	100	3,9	100	3,9	50	380,44	4 x 2 m

Please use LST... snapin splice plates for proper mechanical and electrical connections.

Height 100 mm
Nominal 4 inches

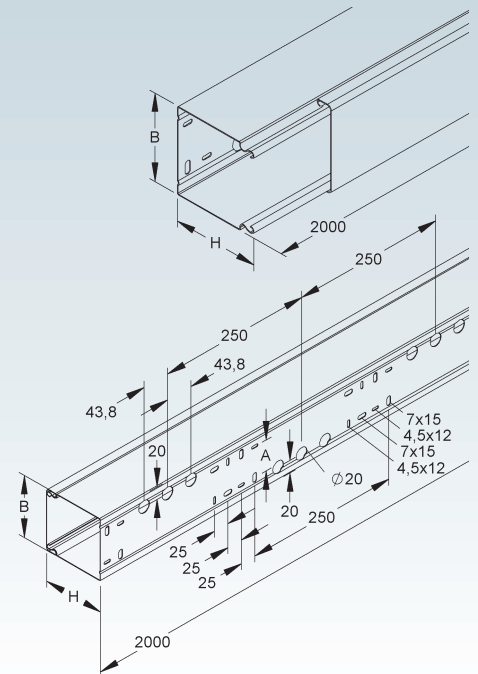

Splice Plate

with flat contact pin (6,3 mm) for protective grounding

Model no.	Height H		Weight per 100 pcs kg	Pack/Box Qty
	mm	Inch		
E3 LSTX 100 E3	100	3,9	4,89	20

mechanical splice and electrical connector for channel cable tray

2 pieces required per joint

Height 100 mm
Nominal 4 inches

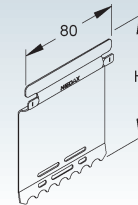

Mounting Plate for Divider

with strain relief

Model no.	Depth T mm	Weight per 100 pcs kg	Pack/ Box Qty
E3 LZTP 100 E3	99	6,13	20



88

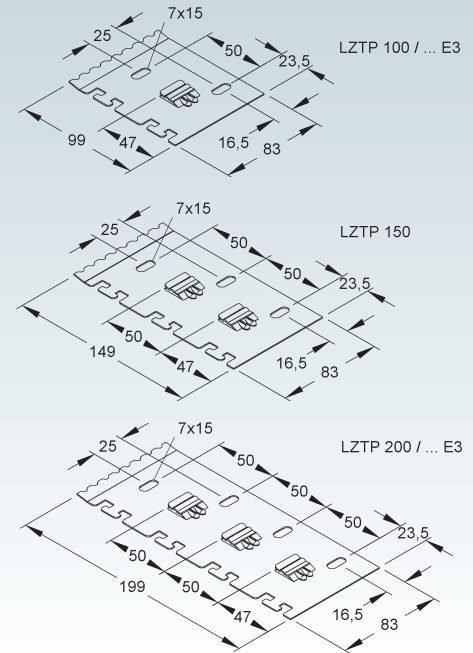

Divider

Model no.	Height H mm Inch	Depth T mm	Weight per 100 m kg	Pack/ Box Qty
E3 TPSX 90 E3	11 0,4	90	76,87	10 x 2 m

to separate wires and cables of different voltage levels or with different functions

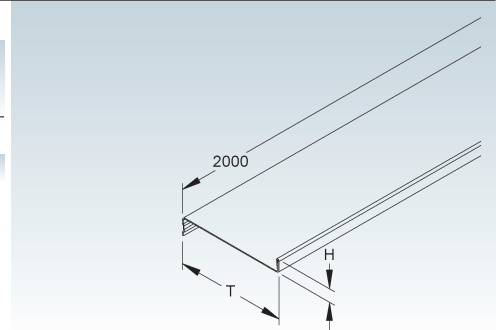

Outside Elbow 45°

cover included

Model no.	Height H mm Inch	Width B mm Inch	Weight per 100 pcs kg	Pack/ Box Qty
E3 LUABX 100.100 E3	100 3,9	100 3,9	77,48	1

Please use LST... snapin splice plates for proper mechanical and electrical connections.
Splice plates have to be ordered separately.

Height
100
mm

Nominal
4
inches

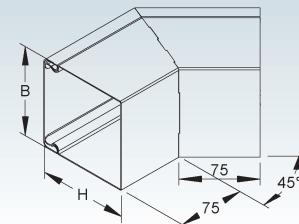

Inside Elbow 45°

cover included

Model no.	Weight per 100 pcs kg	Pack/ Box Qty
E3 LUIBX 100.100 E3	73,17	1

Please use LST... snapin splice plates for proper mechanical and electrical connections.
Splice plates have to be ordered separately.

Height
100
mm

Nominal
4
inches

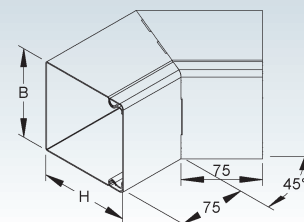

SURFACE METAL RACEWAY

Elbow 45°

cover included

Model no.	Height H mm Inch	Width B mm Inch	Weight per 100 pcs kg	Pack/Box Qty
E3 LUWBX 100.100 E3	100 3,9	100 3,9	77,56	1

Please use LST... snapin splice plates for proper mechanical and electrical connections.
Splice plates have to be ordered separately.

Height 100 mm
Nominal 4 inches

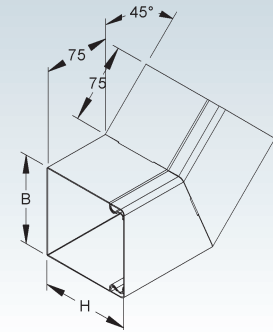

Outside Wide Radius Elbow (2x45°)

cover included

Model no.	Height H mm Inch	Width B mm Inch	Weight per 100 pcs kg	Pack/Box Qty
E3 LUADX 100.100 E3	100 3,9	100 3,9	116,44	1

Please use LST... snapin splice plates for proper mechanical and electrical connections.
Splice plates have to be ordered separately.

Height 100 mm
Nominal 4 inches

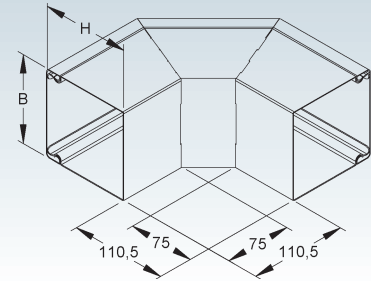

Wide Radius Elbow (2x45°)

cover included

Model no.	Height H mm Inch	Width B mm Inch	Weight per 100 pcs kg	Pack/Box Qty
E3 LUIDX 100.100 E3	100 3,9	100 3,9	107,72	1

Please use LST... snapin splice plates have to be ordered separately.
Splice plates have to be ordered separately.

Height 100 mm
Nominal 4 inches

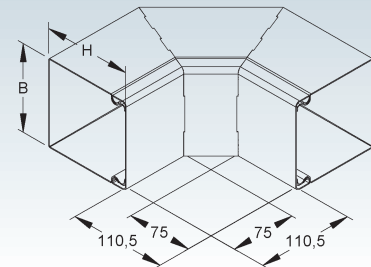

Wide Radius Elbow (2x45°)

Model no.	Height H mm Inch	Width B mm Inch	Weight per 100 pcs kg	Pack/Box Qty
E3 LUWDX 100.100 E3	100 3,9	100 3,9	116,56	1

Please use LST... snapin splice plates for proper mechanical and electrical connections.
Splice plates have to be ordered separately.

Height 100 mm
Nominal 4 inches

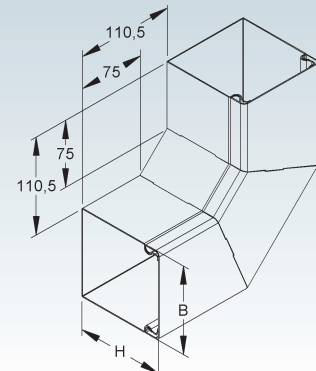

Wide Radius Tee

cover included

Model no.	Height H	Width B	Weight per 100 pcs kg	Pack/ Box Qty
	mm Inch	mm Inch		
E3 LUTCX 100.100 E3	100 3,9	100 3,9	258,96	1

Size of run and tap tray must be identical.

Please use LST... snapin splice plates for proper mechanical and electrical connections.

Splice plates have to be ordered separately.

▲ Height
100
mm
▼

Nominal
4
inches

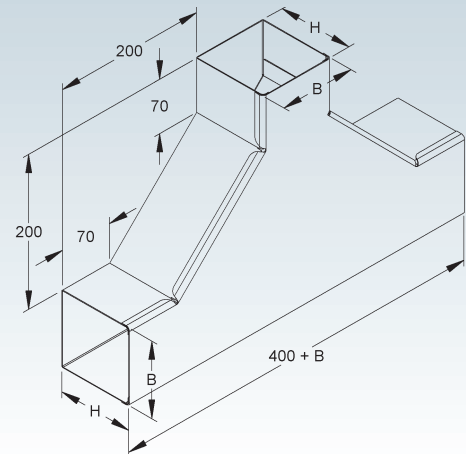

End-Cap

Model no.	Height H	Width B	Weight per 100 pcs kg	Pack/ Box Qty
	mm Inch	mm Inch		
E3 LEDX 100.100 E3	100 3,9	100 3,9	12,78	6

▲ Height
100
mm
▼

Nominal
4
inches

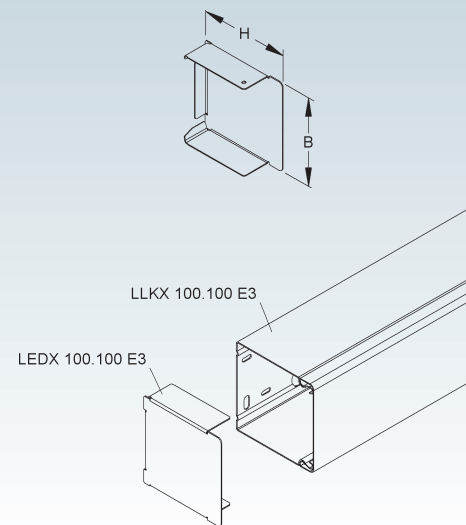

Cable Retainer Clamp

Model no.	Height H	Width B	Weight per 100 pcs kg	Pack/ Box Qty
	mm Inch	mm Inch		
E2 LHS 100.100 E2	100 3,9	55 2,2	2,47	20

▲ Height
100
mm
▼

Nominal
4
inches



88

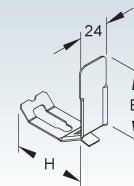

SURFACE METAL RACEWAY

End-Protection Ring

Model no.	Height H		Width B		Similar to RAL	Weight per 100 pcs kg	Pack/Box Qty
	mm	Inch	mm	Inch			
K04 LER 100.100	100	3,9	100	3,9	7021	1,54	10

End caps LER... can be attached to the channel cable tray after installation.

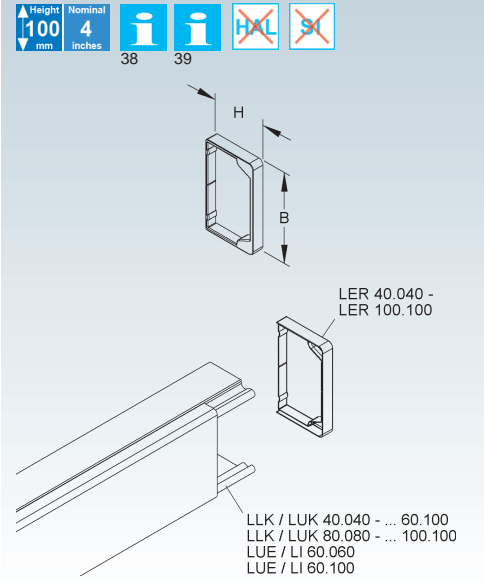

Conversion table of dimensions



1 inch = 25.4 millimeters (mm)

1 millimeter (mm) = 0.039 inch

Material Thickness																
mm	0.6	0.75	0.8	0.9	1.0	1.5	2.0	2.5	3.0	3.5	4.0	4.5	5.0	6.0	7.0	8.0
inch	0.02	0.03	0.03	0.04	0.04	0.06	0.08	0.10	0.12	0.14	0.16	0.18	0.20	0.24	0.28	0.31

Product Length																
mm	30	40	50	70	80	85	90	100	120	130	150	200	250	300	350	400
inch	1.18	1.57	1.97	2.76	3.15	3.35	3.54	3.94	4.72	5.12	5.91	7.87	9.84	11.81	13.78	15.75
mm	450	500	550	600	700	800	900	1000	1100	1200	1300	1400	1500	1600	1700	1800
inch	17.72	19.69	21.65	23.62	27.56	31.50	35.43	39.37	43.31	47.24	51.18	55.12	59.06	62.99	66.93	70.87
mm	1900	2000	3000	4500	6000											
inch	74.80	78.74	118.11	177.17	236.22											

Product Width																
mm	40	50	60	70	75	90	100	120	150	200	250	300	400	500	550	600
inch	1.57	1.97	2.36	2.76	2.95	3.54	3.94	4.72	5.91	7.87	9.84	11.81	15.75	19.69	21.65	23.62
mm	700	800	900	1000	1100	1200										
inch	27.56	31.50	35.43	39.37	43.31	47.24										

Product Height																
mm	10	15	20	25	30	35	40	50	60	85	100	105	110	150	200	
inch	0.39	0.59	0.79	0.98	1.18	1.38	1.57	1.97	2.36	3.35	3.94	4.13	4.33	5.91	7.87	

1 pound (lbs) = 0.453 kilogram (kg)

1 kilogram (kg) = 2.204 pounds (lbs)

Product Weight																
kg	10	20	30	40	45	50	55	60	65	70	75	80	85	90	95	100
lbs	22.05	44.09	66.14	88.18	99.21	110.23	121.25	132.28	143.30	154.32	165.35	176.37	187.39	198.42	209.44	220.46
kg	105	110	115	120	125	130	135	140	150	160	170	180	190	200	210	220
lbs	231.49	242.50	253.53	264.55	275.58	286.60	297.62	308.65	330.69	352.74	374.79	396.83	418.88	440.92	462.97	485.02

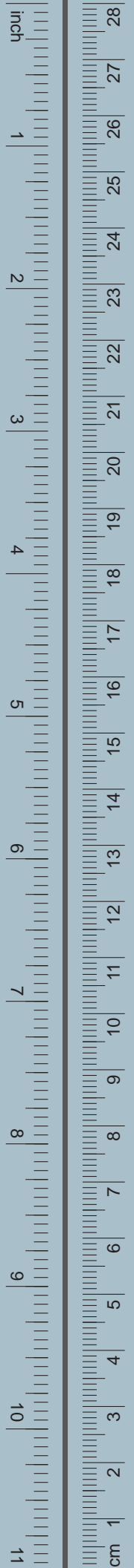



USA

Niedax, Inc.
2970 Charter Street
Columbus | OH 43228
P: +1 614 921 8469
sales@niedaxusa.com
www.niedaxusa.com

Niedax MonoSystems, Inc.
180 Hopkins Street
Buffalo | NY 14220
P: +1 716 821 1344
quotes@monosystems.com
www.monosystems.com

Canada

Niedax Canadian Electrical Raceways, Inc.
2799 Barton Street East
Hamilton, ON L8E 2J8
P: +1 905 337 7522
info@cerinc.ca
www.cerinc.ca

Mexico

Niedax de Mexico S.A. de C.V.
Calle San Bernardo 11C
Puebla | C.P. 72730
P: +52 222 485 0586
salesmex@niedax.com
www.niedaxmex.com

Headquarters

Niedax GmbH & Co. KG
Asbacher Str. 141
D-53545 Linz, Germany
P: +49 2644 56060
export@niedax.de
www.niedax.com

