

Entra nel mondo incantato di

BEST DIVERS

microattrezzatura 2024



P.1 VIVI A COLORI

P.2 • **INDICE • INDEX • INDICE**

P.3 CERCA UN SOGNO

P.4 • **TORCE E ACCESSORI • TORCH AND ACCESSORIES • TORCHES ET ACCESSOIRES**

P.16 • **BOCCAGLI E ACCESSORI • MOUTHPIECES AND ACCESSORIES • EMBOUCHOIRS ET ACCESSOIRES**

P.19 RICORDATI DI GIOCARE

P.20 • **CLIP ESTENSIBILI • CLIP EXTENSIBLE • EXTENSIBLE CLIPS**

P.23 NON PERDERE IL FILO DEL DISCORSO

P.24 • **REEF HOOK, PUNTATORI • REEF HOOK, POINTERS • REEF HOOK, POINTEURS**

P.25 • **MULINELLI • REELS • MOULINETS**

P.26 • **FINGER REELS**

P.28 • **MULINELLI, INDICATORI, SAGOLE • REELS, LINE MARKERS, LINE SPOOLS • MOULINETS, INDICATEURS, LIGNES**

P.30 RISOLVI I CONFLITTI

P.31 • **BOE DECOMPRESSIONE • DECO BUOYS • PARACHUTES DE PALIER**

P.34 • **MOSCHETTONI • CARABINERS • MOSQUETONS**

P.37 • **FIBBIE, ANELLI A "D" • BUCKLES, "D" RINGS • BOUCLES, ANNEAU EN "D"**

P.38 • **O-RINGS • JOINTS**

P.39 CONSERVA I TUOI RICORDI

P.40 • **GEAR AID**

P.44 • **PRODOTTI CURA E MANUTENZIONE • CARE AND MAINTENANCE PRODUCTS • PRODUITS D'ENTRETIEN ET DE MAINTENANCE**

P.46 • **ACCESSORI PER FRUSTE • HOSE ACCESSOIRES • ACCESSOIRES FLEXIBLE**

P.48 ANCHE DA SOLI POSSIAMO FARCELA

P.49 • **FRUSTE MIFLEX • MIFLEX HOSES • FLEXIBLES MIFLEX**

P.51 • **FRUSTE IN GOMMA • RUBBER HOSES • FLEXIBLES EN CAOUTCHOUC**

P.53 LA BELLEZZA SALVERA' IL MONDO

P.54 • **MANOMETRI • PRESSURE GAUGES • MANOMETRES**

P.56 • **SACCHI STAGNI • DRY BAGS • SAC ÉTANCHE**

P.59 • **CONTENITORI • CASES • VALISES**

P.62 • **BORSELLI PORTAEROGATORE • REGULATOR BAGS • SACOCHE DETENDEUR**

P.64 • **TASCHE, BORSE • POCKETS, BAGS • POCHE, SACS**

P.66 QUANDO HAI CHIARO L'OBIETTIVO FAI GOAL

P.67 • **PIOMBI • WEIGHTS • PLOMBS**

P.70 • **CINTURE E FIBBIE • BELTS AND BUCKLES • CEINTURES ET BUCLES**

P.76 • **COLTELLI, UTENSILI • KNIVES, TOOLS • COUTEAUS, OUTILS**

P.79 • **APPENDINI, LENTI, BANDANE • HANGERS, LENSES, BANDANE • CINTRES, LENTILLES, BANDANE**

P.80 • **CINTURINI • STRAPS • SANGLES**

P.88 • **BOE, PLANCETTA • BUOYS, INFLATABLE BOARD • BOUÉE**

P.90 • **PALLONI DA SOLLEVAMENTO, BANDIERE • LIFTING BAGS AND FLAGS • PARACHUTE DE LEVAGE ET DRAPEAU**

P.91 • **BANDIERE • FLAGS • DRAPEAU**

P.93 • **ACCESSORI DI SEGNALAZIONE • SIGNALLING ACCESSORIES • ACCESSOIRES DE SIGNALISATION**

P.94 • **ACCESSORI BOMBOLA • TANK ACCESSOIRES • ACCESSOIRES POUR BOUTEILLES**

P.100 • **ACCESSORI JACKET • BC ACCESSORIES • ACCESSOIRES STAB**

P.103 • **APNEA**

P.104 • **DIVE LOG • CARNET DE PLONGEE**

P.107 • **LAVAGNE • SLATES • ARDOISES**

P.109 • **PORTACHIAVI • KEYCHAINS • PORTE CLE**

P.110 • **ACCESSORI PERSONALIZZABILI • CUSTOMIZED ACCESSORIES • ACCESSOIRES PERSONNALISABLES**

P.117 FACCIAMOCI ACCOMPAGNARE DAGLI AMICI

P.118 • **MACCHINA FOTOGRAFICA E ACCESSORI • CAMERA AND ACCESSORIES • APPAREILS PHOTO ET ACCESSOIRES**

P.120 • **ACTION CAMERA E ACCESSORI • ACTION CAMERA AND ACCESSORIES • ACTION CAMERA ET ACCESSOIRES**

P.127 IL DUBBIO È L'INIZIO DELLA CONOSCENZA

ENTRA NEL MONDO INCANTATO DI BEST DIVERS: **CERCA UN SOGNO**

ENTER THE MAGICAL WORLD OF BEST DIVERS:

LOOKING FOR A DREAM

ENTREZ DANS LE MONDE MAGIQUE DE BEST DIVERS:

À LA RECHERCHE D'UN RÊVE



PYTHON

TRE TORCE, UN UNICO CONCETTO: ERGONOMIA.

Ci siamo concentrati sullo studio di un'impugnatura che con l'inclinazione di 26° permettesse di puntare il fascio con il minimo sforzo.

Ma non ci siamo fermati a questo: spostando l'interruttore nella parte inferiore della testata abbiamo raggiunto il massimo della praticità e del comfort.

Anche il sistema di ricarica è stato completamente rivisto e modificato.

Un innovativo sistema di connessione magnetica permette la ricarica esterna. La batteria agli ioni di litio vi garantirà fino a 500 cicli di ricarica.

Una importante aggiunta è stata fatta per la sicurezza: nella parte posteriore della torcia è stata inserita una valvola di sovrappressione. Questa valvola garantisce che l'interno della torcia non vada mai in sovrappressione.

THREE TORCHES, ONE CONCEPT: ERGONOMICS.

We focused on the design of a grip with a 26° angle that would enable you to point its beam without any effort.

But that is not all: by moving the switch under the head, we achieved the ultimate in functionality and ease of use. The charging system has also been completely revised and modified: an innovative magnetic induction system enables external charging. The lithium-ion battery will guarantee up to 500 charging cycles. We added an important safety feature: a pressure relief valve built into the back of the torch. This valve ensures that the inside of the torch will never overcharge.

LED 1500 lumens

120 m

TROIS TORCHES, UN SEUL CONCEPT: L'ERGONOMIE.

Nous nous sommes concentrés sur la conception d'une poignée qui, avec son inclinaison de 26°, permettrait d'orienter le faisceau avec un minimum d'effort.

Mais nous ne nous sommes pas arrêtés là : en déplaçant l'interrupteur vers la partie inférieure de la tête, nous avons obtenu un maximum de praticité et de confort.

Le système de charge a également été entièrement revu et modifié.

Un système de connexion magnétique innovant permet une recharge externe. La batterie lithium-ion vous offrira jusqu'à 500 cycles de charge.

Un ajout important a été fait pour la sécurité : une soupape de sécurité a été intégrée à l'arrière de la torche. Cette valve permet de s'assurer que l'intérieur de la torche n'est jamais en surpression.



• L'azionamento dell'interruttore consente di passare dal 100% della potenza al 50% e al 30%. Azionando l'**INTERRUTTORE** una quarta volta, si aziona un flash a 10 Hz per segnalare situazioni di emergenza. Inoltre, tenendo l'interruttore premuto per circa 4 secondi, si azionerà il lampeggio di segnalazione nella parte posteriore della torcia.

• Successive activation of the switch cycles through three power levels; from 100% to 50% and 30%. A fourth activation of the **SWITCH** activates a 10 Hz flash to signal an emergency. Furthermore, keeping the switch pressed for about four seconds activates the flashing signal on the back of the torch.

• L'actionnement de l'interrupteur permet de passer de 100% de la puissance à 50% et 30%. En actionnant l'**INTERRUPTEUR** une quatrième fois, on actionne un flash à 10 Hz pour signaler des situations d'urgence. En outre, en maintenant l'interrupteur enfoncé pendant environ 4 secondes, le clignotement de signalisation s'activera à l'arrière de la torche.

• Ricarica esterna con connessione magnetica
• External charge with magnetic connection
• Charge externe avec connexion magnétique

DESIGN



St. Mrs

code	taille/size	descrizione/description/description	colour	euro
A10390	PYTHON Ø 42x170 mm switch mode: 100%-50%-30% flash 10 Hz	<ul style="list-style-type: none"> • PYTHON corpo torcia: policarbonato, parabola: alluminio, ghiera frontale: alluminio anodizzato, lente: vetro temperato, profondità: 120 m, lumen: 1500, led: LUMINUS SST40, 15 W, fascio: 9°, batterie: 1x 21700 Li-Ion 3.7 V 4000 mAh (include), autonomia: 145 min al 100%, interruttore magnetico con blocco, ricarica esterna con connessione magnetica • PYTHON torch body: polycarbonate, reflector: aluminium, front ring: anodised aluminium, lens: tempered glass, depth: 120 m, lumens: 1500, led: LUMINUS SST40, 15 W, beam: 9°, batteries: 1x 21700 Li-Ion 3.7 V 4000 mAh (included), autonomy: 145 min at 100%, magnetic lock switch, external charge with magnetic connection • PYTHON torche corps: polycarbonate, réflecteur: aluminium, anneau frontal: aluminium anodisé, lentille: verre trempé, profondeur: 120 m, lumens: 1500, led: LUMINUS SST40, 15 W, faisceau: 9°, batteries: 1x 21700 Li-Ion 3.7 V 4000 mAh (incluses), autonomie: 145 min à 100%, interrupteur magnétique avec bloqueur, charge externe avec connexion magnétique 	 	136,00

LED 1500 lumens

120 m



- Ricarica esterna con connessione magnetica
- External charge with magnetic connection
- Charge externe avec connexion magnétique



- **Progettata per gli apneisti più estremi, la versione PURE è stata programmata per accendersi e restare accesa tenendo l'**INTERRUTTORE** premuto. Si spegnerà al semplice rilascio dell'interruttore. Nessun'altra opzione.
- **Designed for the most extreme freedivers, the PURE version is configured to remain on as long as the **SWITCH** is pressed. It turns off when you simply release the switch. No other options.
- **Conçue pour les apnéistes les plus extrêmes, la version PURE a été programmée pour s'allumer et rester allumée en maintenant l'**INTERRUPTEUR** enfoncé. Elle s'éteindra dès que l'interrupteur est relâché. Aucune autre option.



Valvola di sovrappressione
Pressure relief valve
Soupape de surpression

- *Studiata per chi ha l'esigenza di utilizzare la torcia in maniera tradizionale sfruttando sempre e solo la piena potenza. Azionando una volta l'**INTERRUTTORE** la torcia si accende al 100%. Al secondo tocco, la torcia si spegnerà. Tenendo l'interruttore premuto per circa 4 secondi si azionerà un flash a 10 Hz per segnalare situazioni di emergenza.
- *Designed for those who need to use their torch in a traditional manner, always on full power only. One **SWITCH** activation turns the torch on at 100% output power. A second touch turns the torch off. Keeping the switch pressed for about 4 seconds activates a 10 Hz emergency flash.
- *Conçue pour ceux qui ont besoin d'utiliser la torche de manière traditionnelle en exploitant toujours et uniquement la pleine puissance. En actionnant une fois l'**INTERRUPTEUR**, la torche s'allume à 100%. Au deuxième contact, la torche s'éteindra. En maintenant l'interrupteur enfoncé pendant environ 4 secondes, un flash à 10 Hz sera activé pour signaler les situations d'urgence.

DESIGN
St. Mrs

DESIGN
St. Mrs

code	taille/size		colour	euro
A10391	COBRA* Ø 42x170 mm	<ul style="list-style-type: none"> • COBRA corpo torcia: policarbonato, parabola: alluminio, ghiera frontale: alluminio anodizzato, lente: vetro temperato, profondità: 120 m, lumen: 1500, led: LUMINUS SST40, 15 W, fascio: 9°, batterie: 1x 21700 Li-Ion 3.7 V 4000 mAh (include), autonomia: 145 min al 100%, interruttore magnetico con blocco, ricarica esterna con connessione magnetica • COBRA torch body: polycarbonate, reflector: aluminium, front ring: anodised aluminium, lens: tempered glass, depth: 120 m, lumens: 1500, led: LUMINUS SST40, 15 W, beam: 9°, batteries: 1x 21700 Li-Ion 3.7 V 4000 mAh (included), autonomy: 145 min at 100%, magnetic switch with external charge, blocker with magnetic connection 	■	126,50
A10392	COBRA PURE** Ø 42x170 mm	<ul style="list-style-type: none"> • COBRA torche corps: polycarbonate, réflecteur: aluminium, anneau frontal: aluminium anodisé, lentille: verre trempé, profondeur: 120 m, lumens: 1500, led: LUMINUS SST40, 15 W, faisceau: 9°, batteries: 1x 21700 Li-Ion 3.7 V 4000 mAh (includes), autonomie: 145 min à 100%, interrupteur magnétique avec bloqueur, de charge externe avec connexion magnétique 		

super BELLATRIX

FASCIO VARIABILE

3 TORCE IN UN UNICO STRUMENTO

Azionando con un semplice movimento di scorrimento la testa anteriore, è possibile variare il fascio luminoso in modo semplice e veloce.

1- FASCIO LARGO 70°:

ideale per immersioni notturne;

2- FASCIO STRETTO 27°:

ideale per illuminare relitti ed anfratti;

3- FASCIO 140°:

svitando completamente e togliendo la testa anteriore,

è possibile ottenere un fascio ideale per video riprese.

VARIABLE BEAM

3 TORCHES IN ONE

By scrolling the torch head you can easily modify the light beam.

1- WIDE BEAM 70°:

perfect for night dives;

2- NARROW BEAM 27°:

perfect to light up wrecks and caves;

3- 140° BEAM: by removing completely the torch head you can obtain a perfect beam to capture videos.

FAISCEAU VARIABLE

3 TORCHES EN UNE

En faisant simplement glisser la tête avant, le faisceau peut être modifié rapidement et facilement.

1- FAISCEAU LARGE DE 70°

idéal pour la plongée de nuit ;

2- FAISCEAU ÉTROIT 27° :



idéal pour éclairer les épaves et les ravins ;

3- FEU 140° :

en dévissant complètement et en retirant la tête avant,

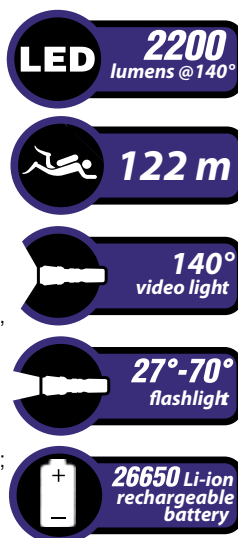
il est possible d'obtenir un faisceau idéal pour le tournage de vidéos.



code	taille/size	descrizione/description/description	colour	euro
  A10395	<ul style="list-style-type: none"> • lunghezza 180 mm, testa Ø 60 mm • length 180 mm, head Ø 60 mm • longueur 180 mm, tête Ø 60 mm 	<p>• SUPER BELLATRIX corpo torcia: alluminio marino anodizzato duro, lumen: 2200, led: CREE XHP50, fascio: angolo di luce regolabile mediante lo scorrimento della testa zoom (27°-140°), profondità: 122 m, batteria: ricaricabile 26650 - 5000 mAh, caricatore: incluso, autonomia: 90 min al 100%, lacciolo: incluso, switch: 100%-50%, colore: BLU</p> <p>• SUPER BELLATRIX housing: hard anodized marine aluminium, lumens: 2200, led: CREE XHP50, beam: light beam angle adjustable by scrolling zoom head (27°-140°), depth: 122 m, battery: 26650 - 5000 mAh rechargeable, charger: included, burn time: 90 min @100%, lanyard: included, switch mode: 100%-50%, colour: BLUE</p> <p>• LAMPE TORCHE SUPER BELLATRIX corps: aluminium marine anodisé dur, lumens: 2200, leds : CREE XHP50, faisceau: angle de lumière réglable en faisant glisser la tête du zoom (27°-140°), profondeur: 122 m, batterie: rechargeable 26650 - 5000 mAh, chargeur: inclus, autonomie: 90 min à 100%, dragonne: incluse, interrupteur: 100%-50%, couleur: BLEU</p>		231,00

LED **1300**
lumens @140°

122 m

140°
video light

13°-50°
flashlight

18650 Li-ion
rechargeable
battery

up BELLATRIX

FASCIO VARIABILE 3 TORCE IN UN UNICO STRUMENTO

Azionando con un semplice movimento di scorrimento la testa anteriore, è possibile variare il fascio luminoso in modo semplice e veloce.

1- FASCIO LARGO 50°:
ideale per immersioni notturne;

2- FASCIO STRETTO 13°:
ideale per illuminare relitti ed anfratti;

3- FASCIO 140°:
svitando completamente e togliendo la testa anteriore, è possibile ottenere un fascio ideale per video riprese.

VARIABLE BEAM

3 TORCHES IN ONE
By scrolling the torch head you can easily modify the light beam.

1- WIDE BEAM 50°:
perfect for night dives;

2- NARROW BEAM 13°:
perfect to light up wrecks and caves;

3- 140° BEAM:
by removing completely the torch head you can obtain a perfect beam to capture videos.

FAISCEAU VARIABLE



3 TORCHES EN UNE
En faisant simplement glisser la tête avant, le faisceau peut être modifié rapidement et facilement.

1- FAISCEAU LARGE DE 50°
idéal pour la plongée de nuit;

2- FAISCEAU ÉTROIT 13°:
idéal pour éclairer les épaves et les ravins;

3- FEU 140°:
en dévissant complètement et en retirant la tête avant, il est possible d'obtenir un faisceau idéal pour le tournage de vidéos.



code	taille/size	descrizione/description/description	colour	euro
<p>DESIGN </p> <p>St. Mrs A10394</p>	<p>• lunghezza 163 mm, testa Ø 48 mm • length 163 mm, head Ø 48 mm • longueur 163 mm, tête Ø 48 mm</p>	<p>• BELLATRIX UP corpo torcia: alluminio marino anodizzato duro, lumen: 1300, led: SST40, fascio: angolo di luce regolabile mediante lo scorrimento della testa zoom (13°-140°), profondità: 122 m, batteria: ricaricabile 18650 - 3200 mAh, caricatore: incluso, autonomia: 90 min al 100%, lacciolo: incluso • BELLATRIX UP housing: hard anodized marine aluminium, lumens: 1300, led: SST40, beam: light beam angle adjustable by scrolling zoom head (13°-140°), depth: 122 m, battery: 18650 rechargeable- 3200 mAh, charger: included, burn time: 90 min @100%, lanyard: included • BELLATRIX UP corps de la torche: aluminium marin anodisé dur, lumens: 1300, leds: SST40, faisceau: angle de lumière réglable en faisant glisser la tête du zoom (13°-140°), profondeur: 122 m, batterie: rechargeable 18650 - 3200 mAh, chargeur: inclus, autonomie: 90 min à 100%, sangle : incluse</p>		155,50



FLASHLIGHT 300 LUMEN

Upgradeable to 500 Lumen

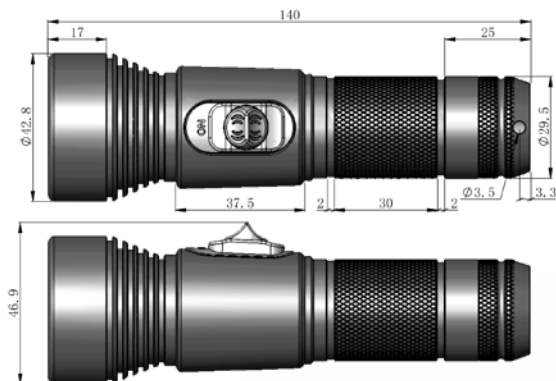



**Questa torcia può essere utilizzata anche con batterie ricaricabili al litio 18650 incrementando la luminosità fino a 500 lumen. Utilizzare la batteria 18650 attenendosi alle istruzioni relative a questo tipo di batteria.

**This torch can also be used with 18650 lithium rechargeable batteries improving brightness up to 500 lumen. Using the 18650 battery, you must follow the instructions for this battery type.

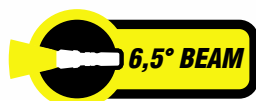
**Cette torche peut également être utilisée avec des piles rechargeables au lithium 18650, ce qui augmente la luminosité jusqu'à 500 lumens. Utilisez la batterie 18650 conformément aux instructions relatives à ce type de batterie.



code	taille/size	descrizione/description/description	colour	euro
  A10386	Ø 42,8x140 mm	<ul style="list-style-type: none"> • XHUNT corpo torcia: alluminio marino anodizzato duro, profondità: 150 m, lumen: 300, led: XP-G2-S3, fascio: 6,5°, batterie: 3xAAA (non incluse), autonomia: 195 min • XHUNT housing: hard anodized marine aluminium, depth: 150 m, lumens: 300, led: XP-G2-S3, beam: 6,5°, batteries 3xAAA (not included), burn time: 195 min • XHUNT corps de la torche: aluminium marin anodisé dur, profondeur: 150 m, lumens: 300, LED: XP-G2-S3, angle de rayonnement : 6,5°, piles: 3xAAA (non incluses), autonomie: 195 min 		61,50



**Rechargeable FLASHLIGHT
920 LUMEN**

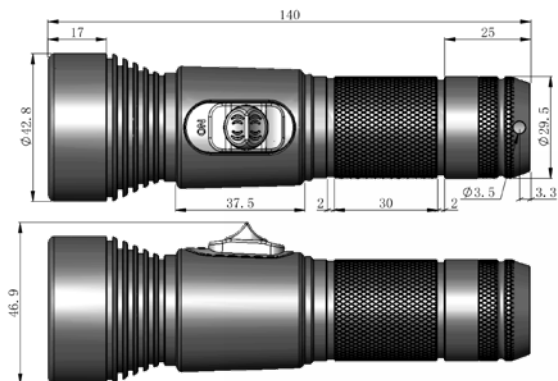



LED 920 LUMENS

18650 Li-ion Rechargeable Battery

150 m

8° BEAM

code	taille/size	descrizione/description/description	colour	euro
  A10387	Ø 42,8x140 mm	<ul style="list-style-type: none"> • XHUNT corpo torcia: alluminio marino anodizzato duro, profondità: 150 m, lumen: 920, led: XPL-V6, fascio: 8°, batterie: 1x18650 Li-ion 3,7 V 2600 mAh ricaricabile inclusa, autonomia: 70 min a piena potenza, switch mode: 100%, 50%, OFF • XHUNT housing: hard anodized marine aluminium, depth: 150 m, lumens: 920, led: XPL-V6, beam: 8°, battery: 1x18650 Li-ion 3,7 V 2600 mAh rechargeable included, burn time: 70 min @full power, switch mode: 100%, 50%, OFF • XHUNT corps de la torche: aluminium marin anodisé dur, profondeur : 150 m, lumens: 920, led: XPL-V6, faisceau: 8°, batteries: 1x18650 Li-ion 3.7 V 2600 mAh rechargeable incluse, autonomie: 70 min à pleine puissance, mode interrupteur : 100%, 50%, OFF 		94,50

ALDEBARAN

3500 LUMEN DI POTENZA E COLORI REALI
3500 LUMEN OF POWER AND REAL COLOURS

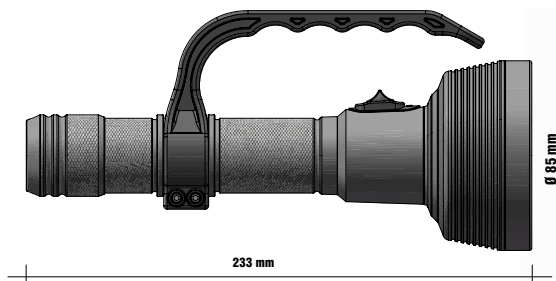

LED 3500 lumens

150 m

14°
FLASHLIGHT

2x26650 Li-ion rechargeable battery



I LED bianchi a 6000°K sono super efficienti. Producono una luce molto intensa e penetrante, ma con scarsa resa delle tonalità rosse. -- ALDEBARAN, grazie al LED ROSSO, le riaccende!

White LEDs 6000°K are very efficient. The light has very good properties and good penetration, but gives very poor reproduction of red colours. -- ALDEBARAN, with the RED LED, switches them on again!

Les LED blanches à 6000°K sont très efficaces. Ils produisent une lumière très intense et pénétrante, mais avec un mauvais rendu des couleurs rouges. -- ALDEBARAN, grâce à la LED rouge, les rallume!

DESIGN

A10385

• peso 645 gr (senza batterie)
 Ø 85x 233 mm
 • weight 645 gr (without batteries)
 Ø 85x 233 mm
 • poids 645 g (sans les piles)
 Ø 85x 233 mm

• **ALDEBARAN** corpo torcia: alluminio marino anodizzato duro, lumen: 3500, led: 4*XML2 U2 + 1*VG65 (correzione di rosso), fascio: 14°, profondità: 150 m, autonomia: 120 min 100%, switch mode: 100% 50% OFF, batterie: 2x26650 3,7 V-5000 mAh, ricaricabili incluse, maniglia: inclusa, caricatore: incluso • **ALDEBARAN** housing: hard anodized marine aluminium, lumens: 3500 led: 4*XML2 U2 + 1*VG65 (red correction), beam: 14°, depth: 150 m, burn time: 120 min 100%, switch mode: 100% 50% OFF, batteries: 2x26650 3,7 V-5000 mAh, rechargeable included, handle: included, charger: included • **ALDEBARAN** corps de la torche: aluminium marin anodisé dur, lumens: 3500, leds: 4*XML2 U2 + 1*VG65 (correction rouge), faisceau: 14°, profondeur: 150 m, autonomie: 120 min 100%, mode interrupteur: 100% 50% OFF, batteries: 2x26650 3.7 V-5000 mAh, rechargeable incluse, poignée: incluse, chargeur: inclus

colour euro



267,00

PULSAR

LED 300 lumens

122 m

SWITCH MODE
1 - strobe

SWITCH MODE
2 - constant on

3x AAA

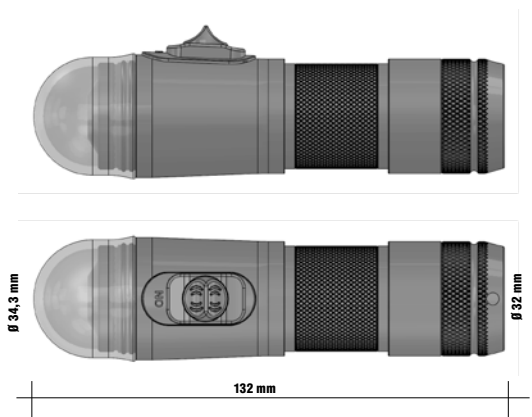

AI0380Y

AI0380



AI0380



AI0354

DESIGN
St. Mrs

DESIGN
St. Mrs

St. Mrs

code	taille/size	descrizione/description/description	colour	euro
AI0380	<ul style="list-style-type: none"> dimensioni: lunghezza 132 mm, testa Ø 34,3 mm dimensioni: length 132 mm, head Ø 34,3 mm dimensions: longueur 132 mm, tête Ø 34,3 mm 	<p>• PULSAR STROBE&LIGHT corpo torcia: alluminio marino anodizzato duro, led: CREE XML, lampada dual mode: strobo+luce, strobo: 80 lampeggi flash /min, luce fissa: 300 lumen, visibilità: oltre 2 miglia in aria chiara, profondità: 122 m, autonomia: 10 ore strobo, 2 ore luce fissa, batterie: 3x AAA (non fornite) • PULSAR STROBE&LIGHT housing: hard anodized marine aluminum, led: CREE XML, dual mode: strobe + flashlight, strobe: 80 flash/min, flashlight: 300 lumens, visibility: 2 miles in clear air, depth: 122 m, burn time: 10 h strobe, 2 h flashlight, batteries: 3x AAA (not included) • PULSAR STROBE&LIGHT corps de la torche: aluminium marin anodisé dur, led: CREE XML, lampe double mode: stroboscopique+lumineux, stroboscopique: 80 flash/min, lumière fixe: 300 lumens, visibilité: plus de 2 miles en air clair, profondeur: 122 m, autonomie: 10 heures en stroboscopique, 2 heures en lumière fixe, piles: 3x AAA (non fournies)</p>	<input type="checkbox"/>	67,00
AI0380Y			<input type="checkbox"/> yellow cap	
AI0354	25 mm	<p>• CINTURINO DI SICUREZZA elastico, chiusura velcro, passante INOX • SAFETY STRAP elastic, velcro strap, S.STEEL loop • CEINTURE DE SÉCURITÉ élastique, fermeture velcro, boucle en acier inoxydable</p>	<input checked="" type="checkbox"/>	8,00



code	taille/size	descrizione/description/description	colour	euro
MD0190	35,5x24,5x11 cm	<ul style="list-style-type: none"> • DISPLAY DA BANCO PER TORCE PYTHON, COBRA, COBRA PURE • TABLE DISPLAY FOR TORCHES PYTHON, COBRA, COBRA PURE • PRÉSENTOIR DE BANC POUR TORCHES PYTHON, COBRA, COBRA PURE 	<input type="checkbox"/>	-



code	taille/size	descrizione/description/description	colour	euro
MD0170	28x33x14 cm	<ul style="list-style-type: none"> • DISPLAY DA BANCO PER TORCE X-HUNT, PULSAR, SUPER BELLATRIX, BELLATRIX UP, X-HUNT R • TABLE DISPLAY FOR TORCHES X-HUNT, PULSAR, SUPER BELLATRIX, BELLATRIX UP, X-HUNT R • PRÉSENTOIR DE BANC POUR TORCHES X-HUNT, PULSAR, SUPER BELLATRIX, BELLATRIX UP, X-HUNT R 	<input type="checkbox"/>	-



AI0366



AI0366R

code	taille/size	descrizione/description/description	colour	euro
AI0366	<ul style="list-style-type: none"> • lunghezza: 10 cm • length: 10 cm • longueur: 10 cm 	<ul style="list-style-type: none"> • MINI TORCH NUMBER ONE peso: 39 gr, materiale: alluminio anodizzato, luminosità: 120 Lumen, profondità: 120 m, autonomia: 8 h, batteria: 1 x AAA inclusa, clip INOX inclusa, lacciolo incluso • MINI TORCH NUMBER ONE material: anodized aluminium, 120 lumens, depth: 120 m, burn time: 8 h, battery: 1 x AAA included, S.STEEL clip included, strap included • MINI TORCH NUMBER ONE poids: 39 gr, matériau: aluminium anodisé, luminosité: 120 lumens, profondeur: 120 m, autonomie: 8 h, batterie: 1 x aaa incluse, clip STEEL inclus, bracelet inclus 		69,50
AI0366R	<ul style="list-style-type: none"> • lunghezza: 10 cm, lente ROSSA • length: 10 cm, RED lens • longueur: 10 cm, lentille ROUGE 			69,50



MD26650







MD18650



MD26650S/O



MD18650S

	code	taille/size	descrizione/description/description	colour	euro
St. Mrs	MD26650	3,7 Volt 5000 mAh	<ul style="list-style-type: none"> • BATTERY KIT batteria al Litio 26650, circuito di sicurezza, carica batteria USB • BATTERY KIT 26650 Lithium battery, safety control circuit, USB charger • BATTERY KIT pile au Lithium 26650, circuit de sécurité, chargeur de pile USB 		43,50
St. Mrs	MD18650	3,7 Volt 3200 mAh	<ul style="list-style-type: none"> • BATTERY KIT batteria al Litio 18650, circuito di sicurezza, caricabatteria USB • BATTERY KIT 18650 Lithium battery, safety control circuit, USB charger • BATTERY KIT pile au Lithium 18650, circuit de sécurité, chargeur de pile USB 		32,50
	MD26650S/O	3,7 Volt 5000 mAh	<ul style="list-style-type: none"> • BATTERY batteria al Litio 26650, circuito di sicurezza - polo positivo alto • BATTERY 26650 Lithium battery, safety control circuit - protruding positive pole • BATTERY pile au Lithium 26650, circuit de sécurité- pôle positif haut 		32,00
St. Mrs	MD26650S	3,7 Volt 5000 mAh	<ul style="list-style-type: none"> • BATTERY batteria al Litio 26650, circuito di sicurezza - polo positivo basso • BATTERY 26650 Lithium battery, safety control circuit - low positive pole • BATTERY pile au Lithium 26650, circuit de sécurité - pôle positif bas 		32,00
St. Mrs	MD18650S	3,7 Volt 3200 mAh	<ul style="list-style-type: none"> • BATTERY batteria al Litio 18650, circuito di sicurezza • BATTERY 18650 Lithium battery safety control circuit • BATTERY pile au Lithium 18650, circuit de sécurité 		17,00



	code	taille/size	descrizione/description/description	colour	euro
DESIGN St. Mrs	AI036C	Ø 25 x 105 mm	<ul style="list-style-type: none"> • GUANTO PORTA TORCIA neoprene fissaggio velcro • TORCH HOLDER GLOVE neoprene velcro fixing • GANT PORTE-TORQUES fixation velcro néoprène 		13,50



CB0352



AI0352KIT



AI0352RO

AI0352VE

code	taille/size	descrizione/description/description	colour	euro
CB0352	1000 h, 100 m 45 pcs	<ul style="list-style-type: none"> • MINI FLASH CANDY BOX led intermittente, accensione automatica "bagnata", candy box: 15 ROSSE+15 VERDI +15 BLU • MINI FLASH CANDY BOX miniflash light, wet contact switch, candy box: 15 RED+15 GREEN+15 BLUE • MINI FLASH CANDY BOX LED intermittente, allumage automatique "humide", candy box: 15 ROUGE +15 VERT +15 BLEU 		-
St. Mrs AI0352KIT	1000 h, 100 m 3 pcs	<ul style="list-style-type: none"> • KIT MINI FLASH led intermittente, accensione automatica "bagnata", cinturino elastico, kit 3 pz: 1 ROSSO+1 VERDE +1 BLU • KIT MINI FLASH miniflash light, wet contact switch, elastic strap, kit 3 pcs:1 RED+1 GREEN+1 BLUE • KIT MINI FLASH LED intermittente, allumage automatique "humide", bracelet élastique, kit 3 pcs: 1 ROUGE +1 VERT +1 BLEU 		40,00
St. Mrs AI0352RO	1000 h, 100 m 1 pc	<ul style="list-style-type: none"> • MINI FLASH led intermittente, accensione automatica "bagnata", cinturino elastico • MINI FLASH miniflash light, wet contact switch, elastic strap • MINI FLASH LED intermittente, allumage automatique "humide", bracelet élastique 		15,50
St. Mrs AI0352BL				
St. Mrs AI0352VE				



AI0376H



AI0354

code	taille/size	descrizione/description/description	colour	euro
DESIGN AI0376H	-	<ul style="list-style-type: none"> • MANIGLIA TORCIA con tappo posteriore di ricarica • TORCH HANDLE with rear handle charger • POIGNÉE DE LA TORCHE avec bouchon de chargement arrière 		38,50
DESIGN AI0354	-	<ul style="list-style-type: none"> • CINTURINO ELASTICO PER miniflash cinturino elastico • ELASTIC STRAP for miniflash elastic strap • SANGLE ÉLASTIQUE POUR MINIFLASH Sangle élastique 		7,00



code	taille/size	descrizione/description/description	colour	euro
AE0273	7x11x5,5 cm	<ul style="list-style-type: none"> • PORTA OCTOPUS Pesce scatola • OCTOPUS HOLDER Boxfish • PORTE OCTOPUS Boxfish 		
AE0277	7x11x5,5 cm	<ul style="list-style-type: none"> • PORTA OCTOPUS Pesce palla • OCTOPUS HOLDER Pufferfish • PORTE OCTOPUS Pufferfish 		22,50
AE0274	7x11x5,5 cm	<ul style="list-style-type: none"> • PORTA OCTOPUS Squalo balena • OCTOPUS HOLDER Whale shark • PORTE OCTOPUS Whaleshark 		



code	taille/size	descrizione/description/description	colour	euro
AE0275	7x11x5,5 cm	<ul style="list-style-type: none"> • PORTA OCTOPUS Aquila di mare • OCTOPUS HOLDER Eagle ray • PORTE OCTOPUS Aigle de mer 		
AE0276	7x11x5,5 cm	<ul style="list-style-type: none"> • PORTA OCTOPUS Megattera • OCTOPUS HOLDER Humpback Whale • PORTE OCTOPUS Baleine à bosse 		22,50
AE0278	6x10,5x6 cm	<ul style="list-style-type: none"> • PORTA OCTOPUS Squalo martello • OCTOPUS HOLDER Hammerhead • PORTE OCTOPUS Requin marteau 		
AE0279	8,5x9x6,5 cm	<ul style="list-style-type: none"> • PORTA OCTOPUS Pesce luna • OCTOPUS HOLDER Mola Mola • PORTE OCTOPUS Poisson lune 		



code	taille/size	descrizione/description/description	colour	euro
AE0283/CF	25 pcs	<ul style="list-style-type: none"> • PORTA OCTOPUS TONDO, adatto ad ogni tipo di boccaglio • OCTOPUS HOLDER ROUND, for any kind of mouthpiece • PORTE OCTOPUS ROND, pour tous les type d'embouchure 		-
AE0283	1 pc			8,50
AE0284/CF	25 pcs			
AE0284	1 pc			8,50
AE0281	1 pc	<ul style="list-style-type: none"> • PORTA OCTOPUS STANDARD, adatto ad ogni tipo di boccaglio • OCTOPUS HOLDER STANDARD, for any kind of mouthpiece • PORTE OCTOPUS STANDARD, pour tous les type d'embouchure 		8,50
AE0282	1 pc			

St. Mrs



CB0227



code	taille/size	descrizione/description/description	colour	euro
AI0227B0	<ul style="list-style-type: none"> nastro NERO, anello silicone Ø 43 x 6 mm BLACK band, silicone ring Ø 43 x 6 mm Bande NOIRE, anneau en silicone Ø 43 x 6 mm 	<ul style="list-style-type: none"> CLIP ANELLO SILICONE clip per octopus con moschettone NYLON SILICONE RING CLIP octopus holder, NYLON carabiner BOUCLE D'ANNEAU EN SILICONE pour octopus avec mousqueton NYLON 		11,50
AI0227BY				
AI0227BB				
AI0227BP				
AI0227Y0	<ul style="list-style-type: none"> nastro GIALLO, anello silicone Ø 43 x 6 mm YELLOW band, silicone ring Ø 43 x 6 mm Bande JAUNE, anneau en silicone Ø 43 x 6 mm 	<ul style="list-style-type: none"> CLIP ANELLO SILICONE clip per octopus con moschettone NYLON SILICONE RING CLIP octopus holder, NYLON carabiner BOUCLE D'ANNEAU EN SILICONE pour octopus avec mousqueton NYLON 		
AI0227YY				
AI0227YB				
AI0227YP				

St. Mrs

St. Mrs

St. Mrs

St. Mrs

code	taille/size	descrizione/description/description	colour	euro
CB0227	48 pcs mix colours	<ul style="list-style-type: none"> CANDY BOX CLIP SILICONE • SILICONE RING CLIP CANDY BOX BOUCLE D'ANNEAU EN SILICONE CANDY BOX 		-



code	taille/size	descrizione/description/description	colour	euro
TK0118	Ø 9 mm 2 pcs	<ul style="list-style-type: none"> COLLARE TECNICO tubino silicone, Ø 22 cm TECHNICAL COLLAR silicone tube, Ø 22 cm COLLIER TECH tube silicone, Ø 22 cm 		20,50
TK0118G				
TK0119N	Ø 8 mm	<ul style="list-style-type: none"> COLLARE TECNICO silicone pieno, Ø 22 cm TECHNICAL COLLAR silicone filled tube, Ø 22 cm COLLIER TECH silicone solide, Ø 22 cm 		22,00
TK0119G				
TK0119F				
TK0119A				
TK0120D	Ø 10 mm	<ul style="list-style-type: none"> COLLARE TECNICO silicone pieno, Ø 22 cm TECHNICAL COLLAR silicone filled tube, Ø 22 cm COLLIER TECH silicone solide, Ø 22 cm 		32,50

St. Mrs

St. Mrs

St. Mrs

St. Mrs



code	taille/size	descrizione/description/description	colour	euro
TK0154	Ø 6,5 mm	<ul style="list-style-type: none"> • TUBETTO SILICONE rotolo 15 m • SILICONE TUBE roll 15 m • TUBE SILICONE rouleau 15 m 	■	96,00
TK0154Y			■	
TK0153	Ø 8 mm		■	146,50
TK0153Y			■	
TK0152	Ø 9 mm		■	218,00
TK0152Y			■	



AE0240



AE0210



AE0200



AE0201



AE0202



AE0206

code	taille/size	descrizione/description/description	colour	euro
AE0240	1 pc	<ul style="list-style-type: none"> • BOCCAGLIO SILICONE STANDARD TRASPARENTE compatibile con tutti gli erogatori • STANDARD SILICONE MOUTHPIECE TRASPARENT compatible with any type of regulator • EMBOUCHOIR SILICONE TRANSPARENT compatible avec tous les détendeurs 	□	12,00
AE0220	50 pcs bag		□	-
AE0210	1 pc	<ul style="list-style-type: none"> • BOCCAGLIO SILICONE STANDARD NERO compatibile con tutti gli erogatori • STANDARD SILICONE MOUTHPIECE BLACK compatible with any type of regulator • EMBOUCHOIR SILICONE NOIR compatible avec tous les détendeurs 	■	12,00
AE0250	50 pcs bag		■	-
St. Mrs AE0200	1 pc	<ul style="list-style-type: none"> • BOCCAGLIO SUPERCONFORT SILICONE compatibile con tutti gli erogatori • SUPERCONFORT MOUTHPIECESILICONE compatible with any type of regulator • EMBOUCHOIR SUPER CONFORT compatible avec tous les détendeurs 	■	11,50
AE0201	1 pc		□	
AE0202	1 pc		■	
St. Mrs AE0206	1 pc	<ul style="list-style-type: none"> • BOCCAGLIO SUPERCONFORT JUNIOR, silicone supersoft • SUPERCONFORT MOUTHPIECE JUNIOR, supersoft silicone mouthpiece • EMBOUCHOIR SUPER CONFORT JUNIOR, silicone très souple 	■	11,50



AE0302



AE0300



AE0301

code	taille/size	descrizione/description/description	colour	euro
AE0300	1 pc	<ul style="list-style-type: none"> • BOCCAGLIO AMMORTIZZATO con cuscinetti ammortizzati • COMFORT CUSHION MOUTHPIECE with cushioned bearings • EMBOUCHOIR COUSSINET CONFORT avec roulements amortis 	■	18,00
AE0301	1 pc		■	
AE0302	1 pc		□	

ENTRA NEL MONDO INCANTATO DI BEST DIVERS: RICORDATI DI GIOCARE

ENTER THE MAGICAL WORLD OF BEST DIVERS:
REMEMBER TO PLAY

ENTREZ DANS LE MONDE MAGIQUE DE BEST DIVERS:
N'OUBLIEZ PAS DE JOUER



code	taille/size	descrizione/description/description	colour	euro
AE0234	-	<ul style="list-style-type: none"> • BOCCAGLIO TERMOFORMATO compatibile con tutti gli erogatori • THERMOFORMED MOUTHPIECE compatible with any type of regulator • EMBOUCHOIR THERMOFORME compatible avec tous les détendeur 		27,50
AE0234L	-			
AE0234B	-			
AE0234C	-			
AE0234P	-			



AI0216SL

AI0192SL

AI0224SL

AI0189SL



St. Mrs

St. Mrs

code	taille/size	descrizione/description/description	colour	euro
AI0216SL	<ul style="list-style-type: none"> • spirale estensibile poliuretano • extensible polyurethane coil 	<ul style="list-style-type: none"> • SMART COIL STANDARD moschettone NYLON 40 mm • SMART COIL STANDARD NYLON carabiner 40 mm • SMART COIL STANDARD mousqueton NYLON 40 mm 	■	20,50
AI0192SL	<ul style="list-style-type: none"> • spirale de polyuréthane extensible 	<ul style="list-style-type: none"> • SMART COIL STRONG ROCCIA moschettone INOX 80 mm • SMART COIL STRONG ROCCIA S.STEEL carabiner 80 mm • SMART COIL STRONG ROCCIA mousqueton INOX 80 mm 	■	29,00
AI0224SL	<ul style="list-style-type: none"> • spirale de polyuréthane extensible 	<ul style="list-style-type: none"> • SMART COIL VELA moschettone INOX 70 mm • SMART COIL VELA S.STEEL carabiner 70 mm • SMART COIL VELA mousqueton INOX 70 mm 	■	29,00
AI0189SL	<ul style="list-style-type: none"> + kevlar: Ø21x 5 mm 	<ul style="list-style-type: none"> • SMART COIL RAPID moschettone INOX 88 mm • SMART COIL RAPID S.STEEL carabiner 88 mm • SMART COIL RAPID mousqueton INOX 88 mm 	■	35,00



AI0216SR

AI0192SR

AI0224SR

AI0189SR



code	taille/size	descrizione/description/description	colour	euro
AI0216SR	<ul style="list-style-type: none"> • spirale estensibile poliuretano • extensible polyurethane coil 	<ul style="list-style-type: none"> • SMART COIL STANDARD moschettone NYLON 40 mm • SMART COIL STANDARD NYLON carabiner 40 mm • SMART COIL STANDARD mousqueton NYLON 40 mm 	■	20,50
AI0192SR	<ul style="list-style-type: none"> • spirale de polyuréthane extensible 	<ul style="list-style-type: none"> • SMART COIL STRONG ROCCIA moschettone INOX 80 mm • SMART COIL STRONG ROCCIA S.STEEL carabiner 80 mm • SMART COIL STRONG ROCCIA mousqueton INOX 80 mm 	■	29,00
AI0224SR	<ul style="list-style-type: none"> • spirale de polyuréthane extensible 	<ul style="list-style-type: none"> • SMART COIL VELA moschettone INOX 70 mm • SMART COIL VELA S.STEEL carabiner 70 mm • SMART COIL VELA mousqueton INOX 70 mm 	■	29,00
AI0189SR	<ul style="list-style-type: none"> + kevlar: Ø21x 5 mm 	<ul style="list-style-type: none"> • SMART COIL RAPID moschettone INOX 88 mm • SMART COIL RAPID S.STEEL carabiner 88 mm • SMART COIL RAPID mousqueton INOX 88 mm 	■	35,00



AI0191

AI0190



code	taille/size	descrizione/description/description	colour	euro
AI0191	<ul style="list-style-type: none"> • spirale estensibile poliuretano • extensible polyurethane coil 	<ul style="list-style-type: none"> • CLIP ESTENSIBILE "RAPID GIREVOLE" 2x moschettone BRONZO 82 mm, anello INOX, terminale in sagola • EXTENSIBLE CLIP "RAPID GIREVOLE" 2x 82 mm BRONZE carabiner, S.STEEL ring, line end • CLIP EXTENSIBILE "RAPID GIREVOLE" 2x mousqueton LAITON 82 mm, anneau INOX, terminal de ligne 	■	52,00
AI0190	<ul style="list-style-type: none"> • spirale de polyuréthane extensible + kevlar: Ø21x 5 mm 	<ul style="list-style-type: none"> • CLIP ESTENSIBILE "RAPID VELA" 2x moschettone "vela" 70 mm, anello INOX, terminale in sagola • EXTENSIBLE CLIP "RAPID VELA" 2x 70 mm carabiner "vela", S.STEEL ring, line end • CLIP EXTENSIBILE "RAPID VELA" 2x mousqueton "vela" 70 mm, anneau INOX, terminal de ligne 	■	32,50



St. Mrs

code	taille/size	descrizione/description/description	colour	euro
AI0216GXL	<ul style="list-style-type: none"> • spirale estensibile poliuretano • extensible polyurethane coil • spirale de polyuréthane extensible Ø25x 6 mm	<ul style="list-style-type: none"> • CLIP COLOUR STRONG ROCCIA moschettone INOX 80 mm • CLIP COLOUR STRONG ROCCIA 80 mm with S.STEEL carabiner • CLIP COLOUR STRONG ROCCIA mousqueton INOX 80 mm 		18,00
AI0216OXL				
AI0216YXL				
AI0216BXL				
AI0216FXL				



St. Mrs

St. Mrs

St. Mrs

St. Mrs

St. Mrs

code	taille/size	descrizione/description/description	colour	euro
AI0192GXL	<ul style="list-style-type: none"> • spirale estensibile poliuretano • extensible polyurethane coil • spirale de polyuréthane extensible Ø25x 6 mm	<ul style="list-style-type: none"> • CLIP COLOUR STANDARD moschettone NYLON 40 mm • CLIP COLOUR STANDARD 40 mm with NYLON carabiner • CLIP COLOUR STANDARD mousqueton NYLON 40 mm 		24,50
AI0192OXL				
AI0192YXL				
AI0192BXL				
AI0192FXL				



St. Mrs

St. Mrs

St. Mrs

code	taille/size	descrizione/description/description	colour	euro
AI0224GXL	<ul style="list-style-type: none"> • spirale estensibile poliuretano • extensible polyurethane coil • spirale de polyuréthane extensible Ø25x 6 mm	<ul style="list-style-type: none"> • CLIP COLOUR VELA moschettone INOX 70 mm • CLIP COLOUR VELA 70 mm with S.STEEL carabiner • CLIP COLOUR VELA mousqueton INOX 70 mm 		26,50
AI0224OXL				
AI0224YXL				
AI0224BXL				
AI0224FXL				



code	taille/size	descrizione/description/description	colour	euro
CB0192		• CLIP COLOUR STRONG ROCCIA CANDY BOX		-
CB0216	10 pcs (2 x colour)	• CLIP COLOUR STANDARD CANDY BOX		-
CB0224		• CLIP COLOUR VELA CANDY BOX		-



code	taille/size	descrizione/description/description	colour	euro
AI0215	-	• CLIP STANDARD clip di bloccaggio per frusta • STANDARD CLIP hose holder clip • STANDARD CLIP clip de blocage pour tuyau		7,50
AI0225	-	• CLIP STANDARD clip con moschettone e sagola • STANDARD CLIP clip with NYLON carabiner and line • STANDARD CLIP clip avec mousqueton et ligne		9,50
AI0202	-	• CLIP STANDARD clip maschio con anello INOX • STANDARD CLIP clip to male with S.STEEL ring • STANDARD CLIP clip mâle avec anneau en acier inoxydable		6,00
AI0201	-	• CLIP STANDARD clip femmina con anello INOX • STANDARD CLIP clip to female with S.STEEL ring • STANDARD CLIP clip femelle avec anneau en acier inoxydable		5,50



code	taille/size	descrizione/description/description	colour	euro
AI0228A	65x55x20 mm	• RETRACTOR LOCK Dyneema® cavo Dyneema® 100 cm, anello INOX • RETRACTOR LOCK Dyneema® Dyneema® cable 100 cm, S.STEEL ring • RETRACTOR LOCK Dyneema® câble Dyneema® 100 cm, anneau INOX		27,50
AI0228DY	55x45x15 mm	• MINI RETRACTOR Dyneema® cavo Dyneema® 69 cm, anello INOX • MINI RETRACTOR Dyneema® Dyneema® cable 69 cm, S.STEEL ring • MINI RETRACTOR Dyneema® câble Dyneema® 69 cm		26,00

St. Mrs

St. Mrs

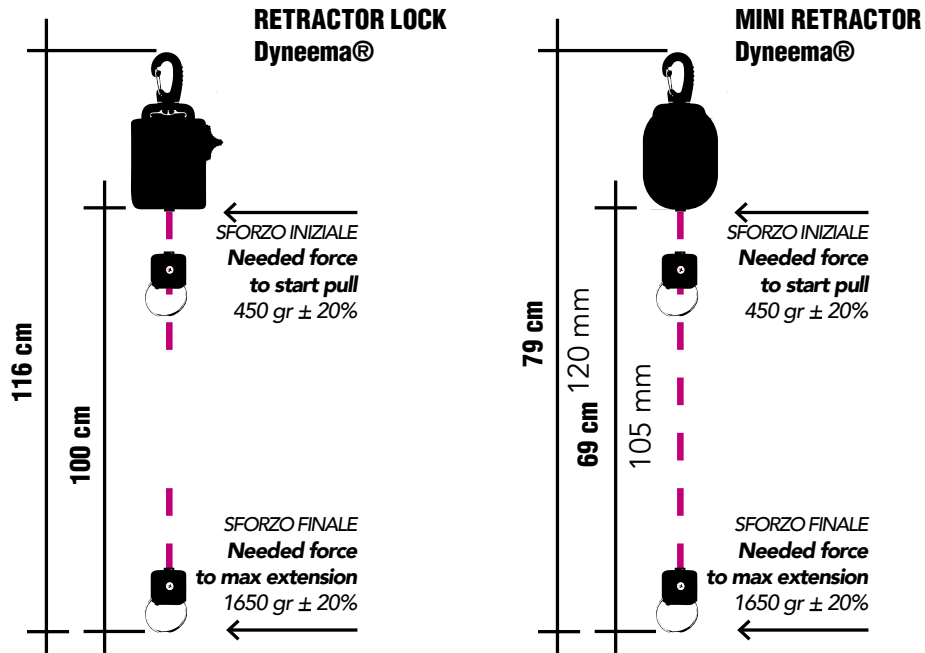

ENTRA NEL MONDO INCANTATO DI BEST DIVERS: NON PERDERE IL FILO DEL DISCORSO

ENTER THE MAGICAL WORLD OF BEST DIVERS:
DON'T LOSE THE THREAD OF THE CONVERSATION
ENTREZ DANS LE MONDE MAGIQUE DE BEST DIVERS:
NE PAS PERDRE LE FIL DU DISCOURS





code	taille/size	descrizione/description/description	colour	euro
TK0200	-	<ul style="list-style-type: none"> • JON LINE COMPLETA gancio INOX, fettuccia NYLON 2 m, moschettone bronzo 88 mm • COMPLETE JON LINE S.STEEL hook, NYLON band 2 m, brass carabiner 88 mm • JON LINE COMPLETE Crochet inox, sangle NYLON 2 m, mousqueton laiton 88 mm 		39,50
TK0126	-	<ul style="list-style-type: none"> • REEF HOOK DOPPIO spirale INOX, moschettone doppio inox 100 mm • DOUBLE REEF HOOK S.STEEL coil, double s.steel carabiner 100 mm • REEF HOOK DOUBLE spirale INOX, mousqueton double en acier inoxydable 100 mm 		50,50
TK0127D	-	<ul style="list-style-type: none"> • REEF HOOK con fodero, sagola 1,4 m, moschettone bronzo 82 mm • REEF HOOK with sheath, line 1,4 m, laiton carabiner 82 mm • REEF HOOK avec gaine, ligne 1,4 m, mousqueton laiton 82 mm 		49,00

St. Mrs

St. Mrs



code	taille/size	descrizione/description/description	colour	euro
TK0200/1	-	<ul style="list-style-type: none"> • JON LINE INOX solo gancio • JON LINE S.STEEL hook only • JON LINE INOX crochet 		15,00
TK0125	-	<ul style="list-style-type: none"> • REEF HOOK solo gancio DOPPIO • REEF HOOK DOUBLE hook only • REEF HOOK crochet double 		15,50
TK0127S	-	<ul style="list-style-type: none"> • REEF HOOK solo gancio SINGOLO • REEF HOOK SINGLE hook only • JON LINE INOX crochet simple 		13,50
TK0113	-	<ul style="list-style-type: none"> • MOLLA INOX per agganciarsi alla sagola • S.STEEL SPRING to hook the line • RESSORT EN ACIER INOXYDABLE pour l'attacheement à la ligne 		8,00

St. Mrs



code	taille/size	descrizione/description/description	colour	euro
TK0129	Ø 6 x 320 mm	<ul style="list-style-type: none"> • PUNTATORE INOX, con anello INOX • POINTER S.STEEL, with S.STEEL ring • POINTEUR INOX, avec anneau en acier inoxydable 		17,00
TK0129BL			16,00	
TK0129OR				
TK0129VE				
TK0129FU				

St. Mrs

St. Mrs

St. Mrs

St. Mrs



ML0077B



ML0077S



ML0077G



St. Mrs

code	taille/size	descrizione/description/description	colour	euro
ML0077B	30 m	<ul style="list-style-type: none"> • REEL F31 Ø 80 mm, foro 31 mm, resina acetilica ad alta resistenza, moschettone INOX 100 mm, sagola ARANCIO Ø1,2 mm • REEL F31 Ø 80 mm, hole 31 mm, high resistance Acetal Resin, S.STEEL carabiner 100 mm, ORANGE line Ø1,2 mm • REEL F31 Ø 80 mm, trou de 31 mm, résine acétal haute résistance, mousqueton en acier inoxydable de 100 mm, ligne ORANGE Ø1,2 mm 		39,00
ML0077S				
ML0077G				



ML0082



ML0086



ML0087



ML0088



St. Mrs

code	taille/size	descrizione/description/description	colour	euro
ML0082	15 m	<ul style="list-style-type: none"> • REEL ALLUMINIO "TECH" ROSSO Ø 69 mm, foro 29 mm, moschettone INOX 100 mm, sagola GIALLA Ø 1,2 mm • ALUMINIUM REEL "TECH" RED Ø 69 mm, hole 29 mm, S.STEEL carabiner 100 mm, YELLOW line Ø 1,2 mm • REEL ALUMINIUM "TECH" ROUGE Ø 69 mm, trou 29 mm, mousqueton INOX 100 mm, ligne JAUNE Ø 1.2 mm 		67,50
ML0086			<ul style="list-style-type: none"> • REEL ALLUMINIO "TECH" VERDE Ø 69 mm, foro 29 mm, moschettone INOX 100 mm, sagola GIALLA Ø 1,2 mm • ALUMINIUM REEL "TECH" GREEN Ø 69 mm, hole 29 mm, S.STEEL carabiner 100 mm, YELLOW line Ø 1,2 mm • REEL ALUMINIUM "TECH" VERT Ø 69 mm, trou 29 mm, mousqueton INOX 100 mm, ligne JAUNE Ø 1.2 mm 	
ML0087	30 m	<ul style="list-style-type: none"> • REEL ALLUMINIO "TECH" ARANCIO Ø 69 mm, foro 29 mm, moschettone INOX 100 mm, sagola GIALLA Ø 1,2 mm • ALUMINIUM REEL "TECH" ORANGE Ø 69 mm, hole 29 mm, S.STEEL carabiner 100 mm, YELLOW line Ø 1,2 mm • REEL ALUMINIUM "TECH" ORANGE Ø 69 mm, trou 29 mm, mousqueton INOX 100 mm, ligne JAUNE Ø 1.2 mm 		75,50
ML0088	45 m	<ul style="list-style-type: none"> • REEL ALLUMINIO "TECH" BLU Ø 69 mm, foro 29 mm, moschettone INOX 100 mm, sagola GIALLA Ø 1,2 mm • ALUMINIUM REEL "TECH" BLUE Ø 69 mm, hole 29 mm, S.STEEL carabiner 100 mm, YELLOW line Ø 1,2 mm • REEL ALUMINIUM "TECH" BLEAU Ø 69 mm, trou 29 mm, mousqueton INOX 100 mm, ligne JAUNE Ø 1.2 mm 		85,50



ML0080V



ML0080R



ML0050



code	taille/size	descrizione/description/description	colour	euro
ML0080V	15 m	<ul style="list-style-type: none"> • FINGER REEL ALLUMINIO Ø 69 mm, foro 29 mm, vuoto • ALUMINIUM FINGER REEL Ø 69 mm, hole 29 mm, empty • FINGER REEL ALUMINIUM Ø 69 mm, trou 29 mm, vide 		55,50
ML0080R				
ML0050		<ul style="list-style-type: none"> • MINI REEL ALLUMINIO Ø 59 mmx42 mm, sagola ARANCIO piatta, foro 25 mm • MINI REEL ALUMINIUM Ø 59 mmx42 mm, flat ORANGE line, hole 25 mm • MINI REEL ALUMINIUM Ø 59 mmx42 mm, ligne plate ORANGE, trou de 25 mm 		53,50



code	taille/size	descrizione/description/description	colour	euro
ML0060	15 m • BIANCA • WHITE • BLANC	<ul style="list-style-type: none"> • FINGER REEL moschettone BRONZO 90 mm, Ø 70 mm, foro 19 mm, sagola Ø 1,2 mm • FINGER REEL BRASS carabiner, 90 mm, Ø 70 mm, hole 19 mm, line Ø 1,2 mm • FINGER REEL mousqueton LAITON 90 mm, Ø 70 mm, trou 19 mm, ligne Ø 1,2 mm 		26,00
ML0060YL	15 m • GIALLA • YELLOW • JAUNE			
ML0060OR	15 m • ARANCIO • ORANGE • ORANGE			
ML0061	30 m • BIANCA • WHITE • BLANC	<ul style="list-style-type: none"> • FINGER REEL moschettone BRONZO 90 mm, Ø 70 mm, foro 19 mm, sagola Ø 1,2 mm • FINGER REEL BRASS carabiner, 90 mm, Ø 70 mm, hole 19 mm, line Ø 1,2 mm • FINGER REEL mousqueton LAITON 90 mm, Ø 70 mm, trou 19 mm, ligne Ø 1,2 mm 		28,50
ML0061YL	30 m • GIALLA • YELLOW • JAUNE			
ML0061OR	30 m • ARANCIO • ORANGE • ORANGE			
ML0062	45 m • BIANCA • WHITE • BLANC	<ul style="list-style-type: none"> • FINGER REEL moschettone BRONZO 90 mm, Ø 70 mm, foro 19 mm, sagola Ø 1,2 mm • FINGER REEL BRASS carabiner, 90 mm, Ø 70 mm, hole 19 mm, line Ø 1,2 mm • FINGER REEL mousqueton LAITON 90 mm, Ø 70 mm, trou 19 mm, ligne Ø 1,2 mm 		31,50
ML0062YL	45 m • GIALLA • YELLOW • JAUNE			
ML0062OR	45 m • ARANCIO • ORANGE • ORANGE			



CB0060



CB0061

code	taille/size	descrizione/description/description	colour	euro
CB0060	6x col. 15 m	<ul style="list-style-type: none"> • FINGER REEL CANDY BOX moschettone OTTONE • FINGER REEL CANDY BOX BRASS carabiner 		-
CB0061	4x col. 30 m	<ul style="list-style-type: none"> • FINGER REEL CANDY BOX mousqueton en LAITON 		-



St. Mrs

St. Mrs

St. Mrs

code	taille/size	descrizione/description/description	colour	euro
ML0055	15 m • BIANCA • WHITE • BLANC	<ul style="list-style-type: none"> • FINGER REEL moschettone INOX 100 mm, Ø 70 mm, foro 19 mm, sagola Ø 1,2 mm • FINGER REEL S.STEEL carabiner, 100 mm, Ø 70 mm, hole 19 mm, line Ø 1,2 mm • FINGER REEL mousqueton en acier inoxydable 100 mm, Ø 70 mm, trou 19 mm, ligne Ø 1,2 mm 		27,50
ML0055YL	15 m • GIALLA • YELLOW • JAUNE			
ML0055OR	15 m • ARANCIO • ORANGE • ORANGE			
ML0055FU	15 m • FUCSIA • PINK • ROSE			
ML0056	30 m • BIANCA • WHITE • BLANC	<ul style="list-style-type: none"> • FINGER REEL moschettone INOX 90 mm, Ø 70 mm, foro 19 mm, sagola Ø 1,2 mm • FINGER REEL S.STEEL carabiner, 90 mm, Ø 70 mm, hole 19 mm, line Ø 1,2 mm • FINGER REEL mousqueton en acier inoxydable 90 mm, Ø 70 mm, trou 19 mm, ligne Ø 1,2 mm 		31,50
ML0056YL	30 m • GIALLA • YELLOW • JAUNE			
ML0056OR	30 m • ARANCIO • ORANGE • ORANGE			
ML0056FU	30 m • FUCSIA • PINK • ROSE			
ML0057	45 m • BIANCA • WHITE • BLANC	<ul style="list-style-type: none"> • FINGER REEL moschettone INOX 90 mm, Ø 70 mm, foro 19 mm, sagola Ø 1,2 mm • FINGER REEL S.STEEL carabiner, 90 mm, Ø 70 mm, hole 19 mm, line Ø 1,2 mm • FINGER REEL mousqueton en acier inoxydable 90 mm, Ø 70 mm, trou 19 mm, ligne Ø 1,2 mm 		33,00
ML0057YL	45 m • GIALLA • YELLOW • JAUNE			
ML0057OR	45 m • ARANCIO • ORANGE • ORANGE			
ML0057FU	45 m • FUCSIA • PINK • ROSE			



code	taille/size	descrizione/description/description	colour	euro
ML0070	50 m	<ul style="list-style-type: none"> • MULINELLO SHORT sagola Ø 1,2 mm, frizione a volantino, ALLUMINIO anodizzato, rocchetto NYLON • SHORT REEL Ø 1,2 mm line, with spring release system, anodized ALUMINIUM, NYLON spool • MOULINET COURT Ø 1,2 mm, embrayage à volant, ALUMINIUM anodisé, bobine NYLON 	<input type="checkbox"/> <input type="checkbox"/>	73,50
ML0075	50 m	<ul style="list-style-type: none"> • MULINELLO LONG sagola Ø 1,2 mm, blocco/sblocco a molla, ALLUMINIO anodizzato, rocchetto NYLON • LONG REEL Ø 1,2 mm line, with spring release system, anodized ALUMINIUM, NYLON spool • MOULINET LONG Ø 1,2 mm, embrayage à volant, ALUMINIUM anodisé, bobine NYLON 	<input type="checkbox"/> <input type="checkbox"/>	71,00
ML0081	30 m	<ul style="list-style-type: none"> • FINGER REEL sagola Ø 2 mm, con maniglia, moschettone OTTONE • FINGER REEL Ø 2 mm line, with handle, BRASS carabiner • FINGER REEL ligne Ø 2 mm, avec poignée, mousqueton en LAITON 	<input type="checkbox"/> <input type="checkbox"/>	48,00
ML0060R	15 m	<ul style="list-style-type: none"> • FINGER REEL VUOTO • EMPTY FINGER REEL • FINGER REEL VIDE 	<input type="checkbox"/>	9,00
ML0060V			<input type="checkbox"/>	
ML0060G			<input type="checkbox"/>	
ML0060B			<input type="checkbox"/>	



AI0065



AI0060



AI0070

code	taille/size	descrizione/description/description	colour	euro
AI0065	-	<ul style="list-style-type: none"> • INDICATORE DI LINEA rettangolare • LINE MARKER rectangular • INDICATEUR DE LIGNE Rectangulaire 	<input type="checkbox"/>	12,50
AI0060	-	<ul style="list-style-type: none"> • INDICATORE DI LINEA freccia • LINE MARKER arrow • INDICATEUR DE LIGNE flèche 	<input type="checkbox"/>	
AI0070	-	<ul style="list-style-type: none"> • INDICATORE DI LINEA “biscotto” • LINE MARKER “cookie” • INDICATEUR DE LIGNE “biscuit” 	<input type="checkbox"/>	



code	taille/size	descrizione/description/description	colour	euro
SG400	Ø 4 mm, 100 m	<ul style="list-style-type: none"> • SAGOLA ELASTICA bobina • ELASTIC LINE spool 	<input type="checkbox"/>	1,80/m
SG600	Ø 6 mm, 100 m	<ul style="list-style-type: none"> • ENROULEUR DE LIGNE ÉLASTIQUE bobine 		2,40/m
SG0026	30 m	<ul style="list-style-type: none"> • SAGOLA PIATTA con swivel, bobina • FLAT LINE with swivel, spool • ENROULEUR DE LIGNE FLAT avec swivel, bobine 	<input type="checkbox"/>	25,50



SG0016/50

SG0015/50

SG0012/50

SG0040/50
SG0040

SG0014/50

code	taille/size	descrizione/description/description	colour	euro
SG0016/50	50 m, Ø 1,2 mm	<ul style="list-style-type: none"> • SAGOLA bobina, carico rottura 75 kg • LINE spool, breaking point 75 kg • LIGNE bobine, charge de rupture 75 kg 		17,20
SG0015/50				
SG0012/50				
SG0014/50				
SG0040/50				
SG0040	100 m, Ø 1,2 mm			23,00



SG0050/G

SG0050/R

SG0050/P

SG0050/V

St. Mrs

code	taille/size	descrizione/description/description	colour	euro
SG0050/G	100 m, Ø 3,5 mm	<ul style="list-style-type: none"> • SAGOLA bobina, carico rottura 150 kg • LINE spool, breaking point 150 kg • LIGNE bobine, charge de rupture 150 kg 		0,41/m
SG0050/P				
SG0050/R				
SG0050/V				



SG0075

SG0070

SG0060

SG0055

code	taille/size	descrizione/description/description	colour	euro
SG0075	50 m, Ø 2,0 mm	<ul style="list-style-type: none"> • SAGOLA Dyneema® SK75 anima interna, carico rottura 240 kg • Dyneema® LINE SK75 internal braided core, breaking point 240 kg • LIGNE Dyneema® SK75 âme interne, charge de rupture 240 kg 		51,50
SG0070	50 m, Ø 1,5 mm	<ul style="list-style-type: none"> • SAGOLA Dyneema® SK75 anima interna, carico rottura 120 kg • Dyneema® LINE SK75 internal braided core, breaking point 120 kg • LIGNE Dyneema® SK75 âme interne, charge de rupture 120 kg 		35,50
SG0060	50 m, Ø 1,0 mm	<ul style="list-style-type: none"> • SAGOLA Dyneema® SK75 anima interna, carico rottura 150 kg • Dyneema® LINE SK75 internal braided core, breaking point 150 kg • LIGNE Dyneema® SK75 âme interne, charge de rupture 150 kg 		35,50
SG0055	50 m, Ø 1,2 mm	<ul style="list-style-type: none"> • SAGOLA Dyneema® SK75 anima interna, carico rottura 90 kg • Dyneema® LINE SK75 internal braided core, breaking point 90 kg • LIGNE Dyneema® SK75 âme interne, charge de rupture 90 kg 		45,00



ENTRA NEL MONDO INCANTATO DI BEST DIVERS: **RISOLVI I CONFLITTI**

ENTER THE MAGICAL WORLD OF BEST DIVERS:
SOLVE THE CONFLICTS

ENTREZ DANS LE MONDE MAGIQUE DE BEST DIVERS:
RÉSOUTRE LES CONFLITS





code	taille/size	descrizione/description/description	colour	euro
St. Mrs AI0927	180x15 cm	<ul style="list-style-type: none"> • BOA DECO PAGLIACCIO boa NYLON/poliuretano con valvola a “becco d’anatra”, valvola di scarico con tirante, aggancio frusta jacket, base piombo • DECO BUOY CLOWN FISH NYLON/polyurethane buoy, semi-closed buoy, one way valve with rapid discharge, BC hose coupling, leaded base • PARACHUTE DE PALIER DECO POISSON CLOWN en NYLON/polyuréthane, avec valve en “bec de canard”, valve de décharge avec tirant, fixation de tuyau de stab, base en plomb 		67,50
St. Mrs AI0928	150x15 cm	<ul style="list-style-type: none"> • BOA DECO DELFINO boa NYLON/poliuretano con valvola a “becco d’anatra”, valvola di scarico con tirante, aggancio frusta jacket, base piombo • DECO BUOY DOLPHIN NYLON/polyurethane buoy, semi-closed buoy, one way valve with rapid discharge, BC hose coupling, leaded base • PARACHUTE DE PALIER POISSON DOLPHIN en NYLON/polyuréthane, avec valve en “bec de canard”, valve de décharge avec tirant, fixation de tuyau de stab, base en plomb 		
St. Mrs AI0929	150 cm	<ul style="list-style-type: none"> • BOA DECO MARTELLA boa NYLON/poliuretano con valvola a “becco d’anatra”, valvola di scarico con tirante, aggancio frusta jacket, base piombo • DECO BUOY HAMMER SHARK NYLON/polyurethane buoy, semi-closed buoy, one way valve with rapid discharge, BC hose coupling, leaded base • PARACHUTE DE PALIER MARTEAU REUIN en NYLON/polyuréthane, avec valve en “bec de canard”, valve de décharge avec tirant, fixation de tuyau de stab, base en plomb 		



AI0921
AI0920
AI0922
AI0923





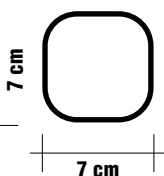

AI0938D

AI0938

AI0939

AI0934



code	taille/size	descrizione/description/description	colour	euro
DESIGN  AI0930N	128x15 cm sagola/line 15 m	<ul style="list-style-type: none"> • MINIDECOSTOP boa PVC, tasca per luce chimica, sacchetto drenante, base piombo, ARANCIO • MINIDECOSTOP PVC buoy, pocket for chemical light, draining bag, leaded base, ORANGE • MINIPARACHUTE bouée en PVC, pochette pour lumière chimique, sac de drainage, base en plomb, ORANGE 		27,50
St. Mrs AI0938D	116x12 cm	<ul style="list-style-type: none"> • BOA DECO "DIR STYLE" boa NYLON/poliuretano chiusa con inflator in metallo • DECO BUOY "DIR STYLE" NYLON/polyurethane, closed buoy with metal inflator • PARACHUTE DE PALIER "DIR STYLE" bouée fermée en NYLON/polyuréthane avec connexion stab en métal 		74,00
St. Mrs AI0938	135x12 cm	<ul style="list-style-type: none"> • BOA DECO boa NYLON/poliuretano con valvola a "becco d'anatra", valvola di scarico con tirante, aggancio frusta jacket, base piombo • DECO BUOY NYLON/polyurethane buoy, semi-closed buoy, one way valve with rapid discharge, BC hose coupling, leaded base 		87,00
AI0939	180x15 cm	<ul style="list-style-type: none"> • PARACHUTE DE PALIER DECO en NYLON/polyuréthane, avec valve en "bec de canard", valve de décharge avec tirant, fixation de tuyau de stab, base en plomb 		95,00
St. Mrs AI0934	142x23 cm, 20 litri/ 20 liters	<ul style="list-style-type: none"> • PEDAGNO TECNICO boa NYLON/poliuretano con chiusura a "becco d'anatra", valvola di scarico con tirante • TECHNICAL BUOY NYLON/polyurethane buoy, semi-closed buoy, one way valve with rapid discharge • PARACHUTE DE PALIER TECH NYLON/polyuréthane avec fermeture "bec de canard", valve de décharge avec tirant 		66,50



DESIGN

DESIGN

DESIGN

code	taille/size	descrizione/description/description	colour	euro
AI0921	135x7 cm • sagola • line • fil 15 m	<ul style="list-style-type: none"> • BOA DECO QUADRA boa NYLON/poliuretano, sacchetto drenante, sezione quadrata • SQUARE DECO BUOY NYLON/polyurethane buoy, draining bag, square section • PARACHUTE DE PALIER CARRÉE boa NYLON/polyuréthane, sac de drainage, section carrée 		48,50
AI0920	135x7 cm, • sagola • line • fil 15 m	<ul style="list-style-type: none"> • BOA DECO "SUPERFLAT" SIMPLY boa NYLON/poliuretano, sezione quadrata • DECO BUOY SIMPLY "SUPERFLAT" NYLON/polyurethane buoy, square section • PARACHUTE DE PALIER "SUPERFLAT" SIMPLY boa NYLON/polyuréthane, section carrée 		30,50
AI0922	135x7 cm, • sagola • line • fil 15 m	<ul style="list-style-type: none"> • BOA DECO QUADRA boa NYLON/poliuretano, sacchetto drenante, sezione quadrata, pedagno 300 gr • SQUARE DECO BUOY NYLON/polyurethane buoy, draining bag, square section, drop weight 300 gr • PARACHUTE DE PALIER CARRÉE boa NYLON/polyuréthane, sac de drainage, section carrée, pedagne 300 gr 		50,50



TK0930

AI0923

AI0910

code	taille/size	descrizione/description/description	colour	euro
TK0930	128x15 cm, sagola/line 15 m	<ul style="list-style-type: none"> • BOA DECO POCKET boa PVC, tasca da gamba, finger reel 15 m • POCKET DECO BUOY PVC buoy, leg pocket, finger reel 15 m • PARACHUTE DE PALIER bouée en PVC, pochette pour les jambes, finger reel 15 m 		67,50
AI0923	135x7 cm, sagola/line 15 m	<ul style="list-style-type: none"> • BOA "SUPERFLAT" boa NYLON/poliuretano, tasca ultra piatta, sezione quadrata • BUOY "SUPERFLAT" NYLON/polyurethane buoy, ultra flat pocket, square section • PARACHUTE DE PALIER "SUPERFLAT" bouée en NYLON/polyuréthane, poche ultra plate, section carrée 		46,00
AI0910	13,5x250 cm	<ul style="list-style-type: none"> • BOA DECO LEGGERA • LIGHT DECO BUOY • PARACHUTE DE PALIER LÉGER 		5,00



TK0245/90
TK0245
TK0245/120



TK0248



TK0245N



TK0245R



TK0245B

code	taille/size	descrizione/description/description	colour	euro
TK0245/90	90 mm	<ul style="list-style-type: none"> • MOSCHETTONE DOPPIO INOX • DOUBLE CARABINER S.STEEL • DOUBLE MOUSQUETON acier inoxiydable 	■	14,50
TK0245	100 mm			15,00
TK0245/120	120 mm			16,50
TK0245N	100 mm	<ul style="list-style-type: none"> • MOSCHETTONE DOPPIO INOX opaco • DOUBLE CARABINER S.STEEL matt • DOUBLE MOUSQUETON acier inoxiydable matt 	■	20,50
TK0245R			■	
TK0245B			■	
TK0248	100 mm	<ul style="list-style-type: none"> • MOSCHETTONE DOPPIO X-BEST INOX • DOUBLE CARABINER X-BEST S.STEEL • DOUBLE MOUSQUETON X-BEST acier inoxiydable 	■	24,00

St. Mrs

St. Mrs

St. Mrs



TK0240
64 mm

TK0241
76 mm

TK0242
88 mm



TK0243
TK0244

code	taille/size	descrizione/description/description	colour	euro
TK0240	64 mm • anello • ring • anneau 10 mm	<ul style="list-style-type: none"> • MOSCHETTONE CON ANELLO INOX • CARABINER WITH RING S.STEEL • MOUSQUETON AVEC ANNEAU acier inoxiydable 	■	12,50
TK0241	76 mm • anello • ring • anneau 13 mm			13,50
TK0242	88 mm • anello • ring • anneau 19 mm			14,00
TK0243	100 mm			16,50
TK0244	120 mm			17,00



TK0246N



TK0247N



code	taille/size	descrizione/description/description	colour	euro
TK0246N	98 mm • anello • ring • anneau 32,8 mm	<ul style="list-style-type: none"> • MOSCHETTONE DIR INOX • CARABINER DIR S.STEEL • MOUSQUETON DIR acier inoxiydable 	■	21,00
TK0247N	115 mm • anello • ring • anneau 32,8 mm			22,00



TK0246

TK0247

TK0249/90

TK0249/100

TK0249/110

code	taille/size	descrizione/description/description	colour	euro
TK0246	98 mm • anello • ring • anneau 28 mm	• MOSCHETTONE DIR INOX • DIR CARABINER S.STEEL • MOUSQUETON DIR acier inoxiydable	■	14,50
TK0247	115 mm • anello • ring • anneau 32,8 mm		■	17,50
TK0249/90	90 mm		■	19,50
TK0249/100	100 mm		■	21,00
TK0249/110	110 mm		■	22,50



50 mm

60 mm

70 mm

80 mm

100 mm

AI0251/2
AI0252
AI0253

St. Mrs

St. Mrs

St. Mrs

code	taille/size	descrizione/description/description	colour	euro
AI0237/2	50 mm, 2 pcs	• MOSCHETTONE STANDARD INOX • STANDARD CARABINER S.STEEL • MOUSQUETON STANDARD acier inoxiydable	■	9,50
AI0238/2	60 mm, 2 pcs			10,50
AI0239/2	70 mm, 2 pcs			12,50
AI0240	80 mm			8,50
AI0241	100 mm			13,00
AI0251/2	50 mm, 2 pcs	• MOSCHETTONE INOX VELA INOX • VELA CARABINER S.STEEL • MOUSQUETON VELA acier inoxiydable	■	11,00
AI0252	70 mm			9,50
AI0253	100 mm			15,50



TK0122/2
TK0123/2
TK0124/2



AI0230/2

code	taille/size	descrizione/description/description	colour	euro
TK0122/2	Ø 30 mm., 2 pcs	• ANELLO INOX chiuso • RING closed S.STEEL • ANNEAU FERMÉ acier inoxiydable	■	6,50
TK0123/2	Ø 50 mm, 2 pcs			8,00
TK0124/2	Ø 60 mm, 2 pcs			10,50
AI0230/2	Ø 30 mm, 2 pcs	• ANELLO A SPIRALE INOX • SPIRAL RING S.STEEL • ANNEAU EN SPIRALE acier inoxiydable		2,50



AI0249
80 mm



AI0248
80 mm



AI0247
60 mm



code	taille/size	descrizione/description/description	colour	euro
AI0249	80 mm	<ul style="list-style-type: none"> • MOSCHETTONE ALLUMINIO anodizzato • ALUMINIUM CARABINER anodized • MOUSQUETON EN ALUMINIUM anodisé 		20,50
AI0248	80 mm			20,00
AI0247	60 mm			15,50



AI0242/2B



AI0243/2B
AI0244/2B



AI0245/2B
AI0246/2B



AI0268/2B

code	taille/size	descrizione/description/description	colour	euro
AI0242/2B	82 mm, 2 pcs	<ul style="list-style-type: none"> • MOSCHETTONE OTTONE girevole • BRASS CARABINER swivel eye • MOUSQUETON EN LAITON avec anneau de pivotement 		30,00
AI0243/2B	56 mm, 2 pcs	<ul style="list-style-type: none"> • MOSCHETTONE OTTONE fisso • BRASS CARABINER fixed eye • MOUSQUETON EN LAITON fixe 		21,50
AI0244/2B	73 mm, 2 pcs			24,50
AI0245/2B	90 mm, 2 pcs	<ul style="list-style-type: none"> • MOSCHETTONE OTTONE doppio • BRASS CARABINER double • MOUSQUETON EN LAITON double 		21,50
AI0246/2B	120 mm, 2 pcs			23,00
AI0268/2B	90 mm, 2 pcs	<ul style="list-style-type: none"> • MOSCHETTONE EASY LOCK ottone • EASY LOCK CARABINER brass • MOUSQUETON EASY LOCK laiton 		19,00



NT016



BOMBOLA ACCIAIO
S.STEEL TANK

	litri/litres	ø/mm
	2,0	114
	3,0	
	5,0	140
	7,0	
	10,0	171
	12,0 lunga/long	
	12,0 corta/short	204
	15,0	

BOMBOLA ALLUMINIO
ALUMINIUM TANK

	litri/litres	ø/mm
	S80 - 11,1	184
	7,0	175
	S40 - 5,7	133
	3,0	111
	1,5	
	0,9	81

code	taille/size	descrizione/description/description	colour	euro
AB0139/5	Ø 70-90 mm	<ul style="list-style-type: none"> • FASCETTA INOX • S.STEEL TANK BAND • CERCLAGE BOUTEILLE ACIER INOXYDABLE 		9,50
AB0139/4	Ø 90-110 mm			10,00
AB0139/6	Ø 100-120 mm			11,00
AB0139/2	Ø 130-150 mm			12,50
AB0139/3	Ø 140-160 mm			13,00
AB0139/1	Ø 160-180 mm			13,50
AB0139/7	Ø 170-190 mm			15,00
AB0140/1	Ø 198-218 mm			15,00
NT016	16 mm	<ul style="list-style-type: none"> • NASTRO TUBOLARE nastro poliestere NERO, (10 m) • TUBULAR BAND BLACK polyester band, (10 m) • BANDE TUBULAIRE 16 mm (Rouleau 10 m) 		17,50



code	taille/size	descrizione/description/description	colour	euro
AB0141/2	2 pcs	• STAFFA INOX per anello "D" • S.STEEL CLAMP for "D" ring • SUPPORT INOX pour anneau en "D"	■	9,00
AB0141	165 mm	• "D" KIT INOX • "D" KIT S.STEEL • "D" KIT INOX		19,00
AB0142	220 mm			20,50



code	taille/size	descrizione/description/description	colour	euro
TK0121/2	2 pcs	• FERMA PIOMBO INOX 3 barre • S.STEEL WEIGHT KEEPER • STOP PLOMB INOX, 3 barres	■	6,50
FI0104/2	2 pcs	• FERMA PIOMBO INOX 3 barre • S.STEEL WEIGHT KEEPER • STOP PLOMB INOX, 3 barres		18,50
TK0121D	-	• FIBBIA INOX LEGGERA con anello • LIGHT S.STEEL BUCKLE with ring • LEGERE BOUCLE INOX avec anneau		13,00
AI0254/S90	90°	• FIBBIA CON ANELLO A "D" INOX • BUCKLE WITH "D" RING S.STEEL • BOUCLE INOX AVEC ANNEAU EN D 90°		21,50
AI0254/S45	45°			21,50
FI0104D	50 mm	• PASSANTE INOX • S.STEEL BUCKLE • BOUCLE INOX POUR CEINTURE		16,50

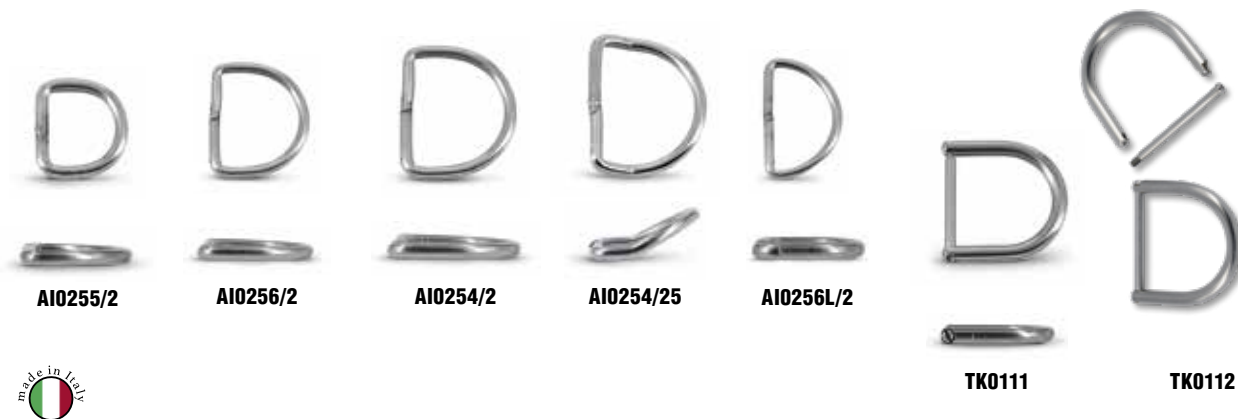

code	taille/size	descrizione/description/description	colour	euro
AI0255/2	25 mm, 2 pcs	• ANELLO A "D" INOX • "D" RING S. STEEL • ANNEAU EN "D" INOX	■	5,50
AI0256/2	40 mm, 2 pcs			6,50
AI0254/2	50 mm, 2 pcs			7,50
AI0254/25	50 mm, 25°			7,50
AI0256L/2	40 mm, 2 pcs			9,00
TK0111	40 mm	• ANELLO SMONTABILE INOX • DETACHABLE RING S. STEEL • ANNEAU EN "D" DETACHABLE INOX		18,50
TK0112	50 mm	• ANELLO A "D" SMONTABILE INOX • DETACHABLE "D" RING S. STEEL • ANNEAU EN "D" DETACHABLE INOX		18,50



code	taille/size	descrizione/description/description	colour	euro
AI0585	12 OR	<ul style="list-style-type: none"> • BOMBOLINA O-RING per rubinetteria standard • TANK KEY-CHAIN for tank valves • PORTE CLE BOUTEILLE pour robinets standard 		16,50
AB0560	10 pcs	<ul style="list-style-type: none"> • KIT O-RING 4 O-R rubinetteria standard, 3 O-R LP, 3 O-R HP • KIT O-RING 4 O-R tank valves, 3 O-R LP, 3 O-R HP • KIT JOINTS 4 O-R robinets standard, 3 O-R LP, 3 O-R HP 	■	7,50
AB0595	40 pcs	<ul style="list-style-type: none"> • KIT O-RING CON SCATOLA 10 O-R rubinetteria standard, 10 O-R LP, 10 O-R HP, 10 O-R swivel • KIT O-RING WITH BEST DIVERS BOX 10 O-R tank valves, 10 O-R LP, 10 O-R HP, 10 O-R swivel • KIT JOINTS avec boîte BEST DIVERS 10 O-R robinets standard, 10 O-R LP, 10 O-R HP, 10 O-R swivel 		15,00

St. Mrs



code	taille/size	descrizione/description/description	colour	euro
AB0460		O-RING DIN compatible with APEKS/ SCUBAPRO	■	
AB0470	300 pcs per attacco DIN 90 sh	O-RING DIN compatible with MARES	■	94,50
AB0480		O-RING DIN compatible with POSEIDON/CRESSI	■	
AB0490	300 pcs per attacco DIN 90 sh	<ul style="list-style-type: none"> • KIT DIN compatibile con: 100 o-r apeks/ scubapro 100 o-r mares 100 o-r poseidon/cressi • KIT DIN compatible with: 100 o-r apeks/ scubapro 100 o-r mares 100 o-r poseidon/cressi • KIT JOINT DIN compatible avec: 100 o-r apeks/ scubapro 100 o-r mares 100 o-r poseidon/cressi 	■	98,00



OR10

code	taille/size	descrizione/description/description	colour	euro
AB0510	10 pcs	<ul style="list-style-type: none"> • O-R STANDARD RUBINETTERIA bombola, 90 sh NBR • STANDARD O-R TANK VALVES for tank valves, 90 sh NBR • JOINTS STANDARD POUR ROBINET, 90 sh NBR 	■	8,50
AB0520	100 pcs			34,50
AB0530	300 pcs			75,00
AB0531	1000 pcs			200,50
AB0534	10 pcs	<ul style="list-style-type: none"> • O-R RIDOTTI RUBINETTERIA bombola, 90 sh NBR • REDUCED O-R TANK VALVES for tank valves, 90 sh NBR • REDUCED JOINT POUR ROBINET, 90 sh NBR 	■	8,50
AB0533	300 pcs			102,00
AB0532	1000 pcs			243,00
AB0541	10 pcs	<ul style="list-style-type: none"> • O-R LP BASSA PRESSIONE 70 sh NBR • LP O-R LOW PRESSURE 70 sh NBR • JOINTS BASSE PRESSION 70 sh NBR 	■	6,50
AB0540	50 pcs			10,50
AB0551	10 pcs	<ul style="list-style-type: none"> • O-R HP ALTA PRESSIONE 70 sh NBR • LP O-R HIGH PRESSURE 70 sh NBR • JOINTS HAUT PRESSION 70 sh NBR 	■	7,00
AB0550	50 pcs			14,50
OR10	100 pcs	• O-R SWIVEL		27,00

St. Mrs

St. Mrs

ENTRA NEL MONDO INCANTATO DI BEST DIVERS: **CONSERVA I TUOI RICORDI**

ENTER THE MAGICAL WORLD OF BEST DIVERS:

PRESERVE YOUR MEMORIES

ENTREZ DANS LE MONDE MAGIQUE DE BEST DIVERS:

CONSERVEZ VOS SOUVENIRS



GEAR AID



MC210011



MC210012



MC210013



MC210014

code	taille/size	descrizione/description/description	colour	euro
MC210011	MINI	• HEROCLIP		26,00
MC210012	SMALL			30,50
MC210013	MEDIUM			34,00
MC210014	LARGE			41,00



	code	taille/size	descrizione/description/description	colour	euro
St. Mrs	MC91520	3x COLOUR	• NI-GLO™ DISPLAY		-
St. Mrs	MC91500	Crystal clear	• NI-GLO™ MARCATORE LUMINOSO • NI-GLO™ GLOW MARKER • NI-GLO™ MARQUEUR LUMINEUX		8,50
St. Mrs	MC91501	Dragon green			
St. Mrs	MC91502	Blaze orange			
St. Mrs	MC91503	Panther pink			
St. Mrs	MC91504	Sour lemon			
St. Mrs	MC91505	Atomic blue			





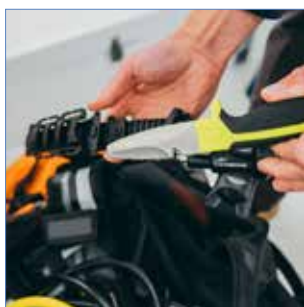

code	taille/size	descrizione/description/description	colour	euro
MC68150	51x102 cm 100 gr	• TELO MICROFIBRA • MICROFIBER TOWEL • SERVETTE EN MICROFIBRE		23,50
MC68151	77x128 cm 180 gr			31,50
MC68152	90x157 cm 260 gr			40,00



MC62070

MC62075

code	taille/size	descrizione/description/description	colour	euro
MC62070	<ul style="list-style-type: none"> • lama • blade • lame 7,6 cm 	<ul style="list-style-type: none"> • TANU KNIFE acciaio INOX 304 • TANU KNIFE 304 S.STEEL • TANU KNIFE en acier inoxidable 304 		60,50
MC62071				
MC62072	<ul style="list-style-type: none"> • lama • blade • lame 7,6 cm 	<ul style="list-style-type: none"> • TANU KNIFE acciaio INOX 304, adattatore per jacket • TANU KNIFE 304 S.STEEL, BC adaptor plate • TANU KNIFE en acier inoxidable 304, adaptateur de stab 		69,50
MC62075				



MC12016



MC12718



MC10719



MC10116



MC11146



MC14324



MC10184

	code	taille/size	descrizione/description/description	colour	euro
St. Mrs	MC12016	30 ml	<ul style="list-style-type: none"> • COTOL 240 accelerante per Aquasure • COTOL 240 accélérateur pour Aquasure 	-	18,00
	MC12718	1 l		-	91,00
	MC10719	250 gr	<ul style="list-style-type: none"> • AQUASURE™ adesivo universale • AQUASURE™ universal adhesive • AQUASURE™ colle universelle 	-	59,50
St. Mrs	MC10116	28,4 gr		-	17,50
St. Mrs	MC11146	2x 7gr		-	
St. Mrs	MC14324	28 gr	<ul style="list-style-type: none"> • BLACK WITCH™ mastice neoprene NERO • BLACK WITCH™ BLACK adhesive for neoprene • BLACK WITCH™ colle néoprène NOIR 	■	14,00
St. Mrs	MC10184	7 gr	<ul style="list-style-type: none"> • KIT DI RIPARAZIONE Aquasure 7 gr + pezze adesive • REPAIR KIT Aquasure 7 gr + adhesive patches • WATERSPORT KIT REPARATION Aquasure 7 gr + patches adhésifs 	-	17,50



MC40791



MC40230



MC40854



MC40832

	code	taille/size	descrizione/description/description	colour	euro
	MC40791	60 ml	<ul style="list-style-type: none"> • GOOGLE BRIGHT™ antiappannante per occhialini nuoto • GOOGLE BRIGHT™ anti fog for goggles • GOOGLE BRIGHT™ anti-buée pour lunettes de natation 	-	14,50
St. Mrs	MC40230	37 ml	<ul style="list-style-type: none"> • SEA DROP™ antiappannante • SEA DROP™ anti fog • SEA DROP™ antibuée 	-	
St. Mrs	MC40854	37 ml	<ul style="list-style-type: none"> • SEA GOLD™ antiappannante in gel • SEA GOLD™ anti fog gel • SEA GOLD™ gel antibuée 	-	14,50
St. Mrs	MC40832	37 ml	<ul style="list-style-type: none"> • SEA BUFF™ pre-pulitore per maschere nuove • SEA BUFF™ pre-cleaner for new masks • SEA BUFF™ pre-cleaner pour les nouveaux masques 	-	12,00



MC24118

code	taille/size	descrizione/description/description	colour	euro
MC24118	37 ml	<ul style="list-style-type: none"> • SEAL SAVER™ protegge guarnizioni in lattice e silicone, O-ring e prodotti in gomma • SEAL SAVER™ protects and conditions dry suit seals, O-rings and rubber • SEAL SAVER™ protège les joints en latex et en silicone, les joints toriques et les produits en caoutchouc 	-	13,00



MC91120



MC29118



MC22112



MC91243

code	taille/size	descrizione/description/description	colour	euro
MC91120	2x4,8 gr	<ul style="list-style-type: none"> • ZIP TECH™ 2 tubetti, liquido lubrificante per cerniere plastica • ZIP TECH™ 2 tubes, plastic zip oil • ZIP TECH™ 2 tubes, lubrifiant pour charnières en plastique 	-	13,00
MC29118	60 ml	<ul style="list-style-type: none"> • ZIP CARE™ liquido lubrificante per cerniere • ZIP CARE™ liquid lubricant for zip • ZIP CARE™ lubrifiant pour charnières 	-	13,50
MC22112	250 ml	<ul style="list-style-type: none"> • SILICONE PROTECTANT™ silicone liquido • SILICONE PROTECTANT™ liquid silicone grease • SILICONE PROTECTANT™ silicone liquide 	-	13,00
MC91243	500 ml	<ul style="list-style-type: none"> • SILICONE LUBRICANT™ silicone spray lubrificante • SILICONE LUBRICANT™ lubricant spray silicone • SILICONE LUBRICANT™ lubrifiant silicone en spray 	-	22,50



MC34120



MC30122



MC20000



code	taille/size	descrizione/description/description	colour	euro
MC34120	237 ml	<ul style="list-style-type: none"> • B.C. LIFE™ shampoo per jacket • B.C. LIFE™ BC shampoo • B.C. LIFE™ shampooing par stab 	-	17,00
MC30122	250 ml	<ul style="list-style-type: none"> • WET & DRY SUIT SHAMPOO™ per mute sub • WET & DRY SUIT SHAMPOO™ for dive suits • WET & DRY SUIT SHAMPOO™ pour les combinaisons de plongée 	-	16,50
MC20000	250 ml	<ul style="list-style-type: none"> • NEO-SLICS NEO-SLIX™ Lubrificante per mute in neoprene • NEO-SLICS NEO-SLIX™ Neoprene wet suit entry lubricant • NEO-SLICS NEO-SLIX™ Lubrifiant pour combinaisons en néoprène 	-	14,50

St. Mrs

St. Mrs

St. Mrs



	code	taille/size	descrizione/description/description	colour	euro
St. Mrs	CB1055	box 24x 30 ml	• ANTIAPPANNANTE CANDY BOX • ANTI FOG CANDY BOX • ANTI-BUEE CANDY BOX	-	-
	AI1050/1	1x 30 ml	• ANTIAPPANNANTE ideale per evitare la condensa sulle maschere • ANTI FOG to avoid mask condensation • ANTI-BUEE idéal pour éviter la condensation sur les masques	-	8,50
St. Mrs	CB1075	box 24x 30 gr	• ZIP WAX CANDY BOX	-	-
St. Mrs	AI1070/S	1x 30 gr	• ZIP WAX paraffina ideale per lubrificare cerniere di mute e borse • ZIP WAX ideal to lubricate zippers for drysuits, wetsuits and bags • PARAFFINE idéale pour lubrifier les fermetures éclair des combinaisons et des sacs	-	11,50
St. Mrs	CB1045	box 24x 30 gr	• MASTICE NEOPRENE CANDY BOX • NEOPRENE GLUE CANDY BOX • COLLE NÉOPRÈNE CANDY BOX	-	-
St. Mrs	AI1040/1	1x 30 gr	• MASTICE NEOPRENE colla per la riparazione di mute in neoprene • NEOPRENE GLUE to repair neoprene wetsuits • COLLE NÉOPRÈNE colle pour la réparation des combinaisons en néoprène	■	7,00



	code	taille/size	descrizione/description/description	colour	euro
	AI1030	box 9x 125 gr	• TALCO MINERALE • MINERAL TALCUM • TALC MINERAL	-	-
	AI1030/SE	1x 125 gr	• TALCO MINERALE ideale per la manutenzione di parti in lattice • MINERAL TALCUM ideal for latex parts maintenance • TALC MINERAL idéal pour l'entretien des pièces en latex	-	11,50
	AI1032	500 gr	• TALCO MINERALE • MINERAL TALCUM • TALC MINERAL	-	17,00
St. Mrs	AI1065	box 24x 10 gr	• GRASSO SILICONE • SILICONE GREASE • GRAISSE SILICONE	-	-
	AI1064	1x 10 gr	• GRASSO SILICONE ottimo per lubrificare guarnizioni e O-ring • SILICONE GREASE excellent to lubricate seals and O-rings • GRAISSE SILICONE excellent pour la lubrification des joints d'étanchéité et des joints toriques	-	9,50



	code	taille/size	descrizione/description/description	colour	euro
St. Mrs	AI1035	-	• KIT PRODOTTI CURA E MANUTENZIONE antiappannante, grasso silicone, mastice, zip wax • CURE AND MAINTENANCE PRODUCT KIT anti fog, silicone grease, neoprene glue, zip wax • KIT DE PRODUITS D'ENTRETIEN ET DE MAINTENANCE anti-buée, graisse silicone, colle néoprène, zip wax	-	40,50



code	taille/size	descrizione/description/description	colour	euro
AI1098/500	500 ml	• BIO BAGNODOCCIA • BIO SHOWER GEL • GEL DOUCHE BIO		15,00
CB1096	12x 75 ml	• GEL IGIENIZZANTE • SANITISING GEL • GEL ANTISEPTIQUE		5,00



code	taille/size	descrizione/description/description	colour	euro
AI1020/1	50 ml	• GEL DOPO PICK MEDUSE • AFTER JELLYFISH PICK GEL • GEL APAISANT PIQURE MEDUSE	-	14,50
AI1021/1	100 ml	• SPRAY DOPO PICK MEDUSE • AFTER JELLYFISH PICK SPRAY • SPRAY APAISANT PIQURE MEDUSE		



code	taille/size	descrizione/description/description	colour	euro
AI1025	4x 6 colours 24 pcs	• SCUBA GOOP DISPLAY	-	-
AI1330BI	29,5 ml 1 pcs	• SCUBA GOOP marcatore per neoprene, metallo, tessuto, gomma, plastica (non usare su silicone) • SCUBA GOOP marker paint: works on neoprene, metal fabric, rubber, plastic (do not use on silicone) • SCUBA GOOP marqueur pour néoprène, métal, tissu, caoutchouc, plastique (ne pas utiliser sur le silicone)		9,50
AI1333AR				
AI1334FU				
AI1335RO				
AI1338GI				
AI1339VE				

St. Mrs

St. Mrs

St. Mrs

St. Mrs



code	taille/size	descrizione/description/description	colour	euro
CB0236	BOX 60 pcs	<ul style="list-style-type: none"> • CANDY BOX REGGIFRUSTA 30 reggifrusta blocco INOX GIALLO + 30 NERO • HOSE HOLDERS - CANDY BOX S.STEEL block hose holder 30 YELLOW + 30 BLACK • CANDY BOX - ACCROCHE TUYAU fermature inox 30 JAUNE + 30 NOIR 		-
<i>St. Mrs</i> AI0236/2	2 pcs	<ul style="list-style-type: none"> • REGGIFRUSTA BLOCCO INOX NYLON, per l'attacco di 2 fruste, per ogni diametro di frusta • HOSE HOLDERS S.STEEL BLOCK NYLON, to attach two hoses of any diameter • CLIP ACCROCHE TUYAU NYLON, pour la fixation de 2 tuyaus, pour tous le diamètre de tuyau 		10,50
<i>St. Mrs</i> AI0236G/2	2 pcs			
AI0236H/2	Ø 6 2 pcs			



code	taille/size	descrizione/description/description	colour	euro
<i>St. Mrs</i> AI0725G	-	<ul style="list-style-type: none"> • REGGIFRUSTA MAGNETICO per fruste Ø 10/12 mm, Ø 6/7 mm • MAGNETIC HOSE HOLDER for hoses Ø 10/12 mm, Ø 6/7 mm • SUPPORT FLEXIBLE MAGNÉTIQUE pour tuyau Ø 10/12 mm, Ø 6/7 mm 		14,50
<i>St. Mrs</i> AI0725N	-			
<i>St. Mrs</i> AI0725R	-			
AI0235/2	2 pcs	<ul style="list-style-type: none"> • REGGIFRUSTA MULTIPLO NYLON, per l'attacco di 2 fruste, per ogni diametro di frusta • HOSE HOLDERS NYLON, to attach two hoses of any diameter • SUPPORT FLEXIBLE MULTIPLE NYLON, pour la fixation de 2 tuyau, pour tous le diamètre de tuyau 		8,00
AI0233/2	2 pcs	<ul style="list-style-type: none"> • REGGIFRUSTA SFALSATO NYLON, per l'attacco di 2 fruste, per ogni diametro di frusta • ASYMMETRIC HOSE HOLDERS to attach 2 hoses of any diameter • SUPPORT FLEXIBLE DOUBLE NYLON, pour la fixation de 2 tuyau, pour tous le diamètre de tuyau 		10,50

AI0234N
AI0234F
AI0234G



code	taille/size	descrizione/description/description	colour	euro
AI0234F	-	<ul style="list-style-type: none"> • REGGIFRUSTA PARALLELO per l'attacco di 2 fruste, corpo NYLON per ogni diametro di frusta • PARALLEL HOSE HOLDER to attach two hoses, NYLON body, for hoses of any diameter • SUPPORT PARALLELE DOUBLE pour la fixation de 2 tuyau, corps en NYLON pour tous le diamètre de tuyau 		7,50
AI0234N	-			
AI0234G	-			



AE0360/2



AE0361/2



AE0363/2



AE0364/2



AE0362/2

code	taille/size	descrizione/description/description	colour	euro
AE0360/25	25 pcs	<ul style="list-style-type: none"> • SALVAFRUSTA termo gomma, adatto a fruste standard • HOSE PROTECTOR thermo rubber, suitable for standard hoses • PROTECTEUR TUYAU caoutchouc thermo, adapté aux tuyaus standard 		54,50
AE0360/2	2 pcs			8,00
AE0361/25	25 pcs			54,50
AE0361/2	2 pcs			8,00
AE0363/2	2 pcs			8,00
AE0364/2	2pcs			8,00
AE0362/2	2pcs			8,00



AE0400



AE0405/5

AE0400/100	100 pcs bag	<ul style="list-style-type: none"> • SWIVEL per frusta alta pressione • SWIVEL for high pressure hose • PIVOT pour tuyau haut pression 		294,50
AE0400/20	20 pcs bag			63,50
AE0400/5	5 pcs bag			18,50
AE0405/5	5 pcs bag	<ul style="list-style-type: none"> • VALVOLA per frusta jacket mixflex • VALVE for bc hose mixflex • VALVE pour tuyau stab mixflex 		19,00

AE0370



AE0375



AE0370	Ø 2x11 cm	<ul style="list-style-type: none"> • AIR GUN corpo in gomma, innesto standard per frusta jacket • AIR GUN rubber body, standard connection to BC hose • AIR GUN corps en caoutchouc, accouplement standard à enveloppe tuyau 		25,00
AE0375	23x9 cm	<ul style="list-style-type: none"> • MAXI AIR GUN impugnatura a pistola, innesto standard per frusta jacket • MAXI AIR GUN standard connection to BC hose • MAXI AIR GUN poignée pistolet, accouplement standard à gaine tuyau 		48,50

ENTRA NEL MONDO INCANTATO DI BEST DIVERS: **ANCHE DA SOLI POSSIAMO FARCELA**

ENTER THE MAGICAL WORLD OF BEST DIVERS:

EVEN ALONE WE CAN DO IT

ENTREZ DANS LE MONDE MAGIQUE DE BEST DIVERS:

MÊME SEUL, NOUS POUVONS Y ARRIVER

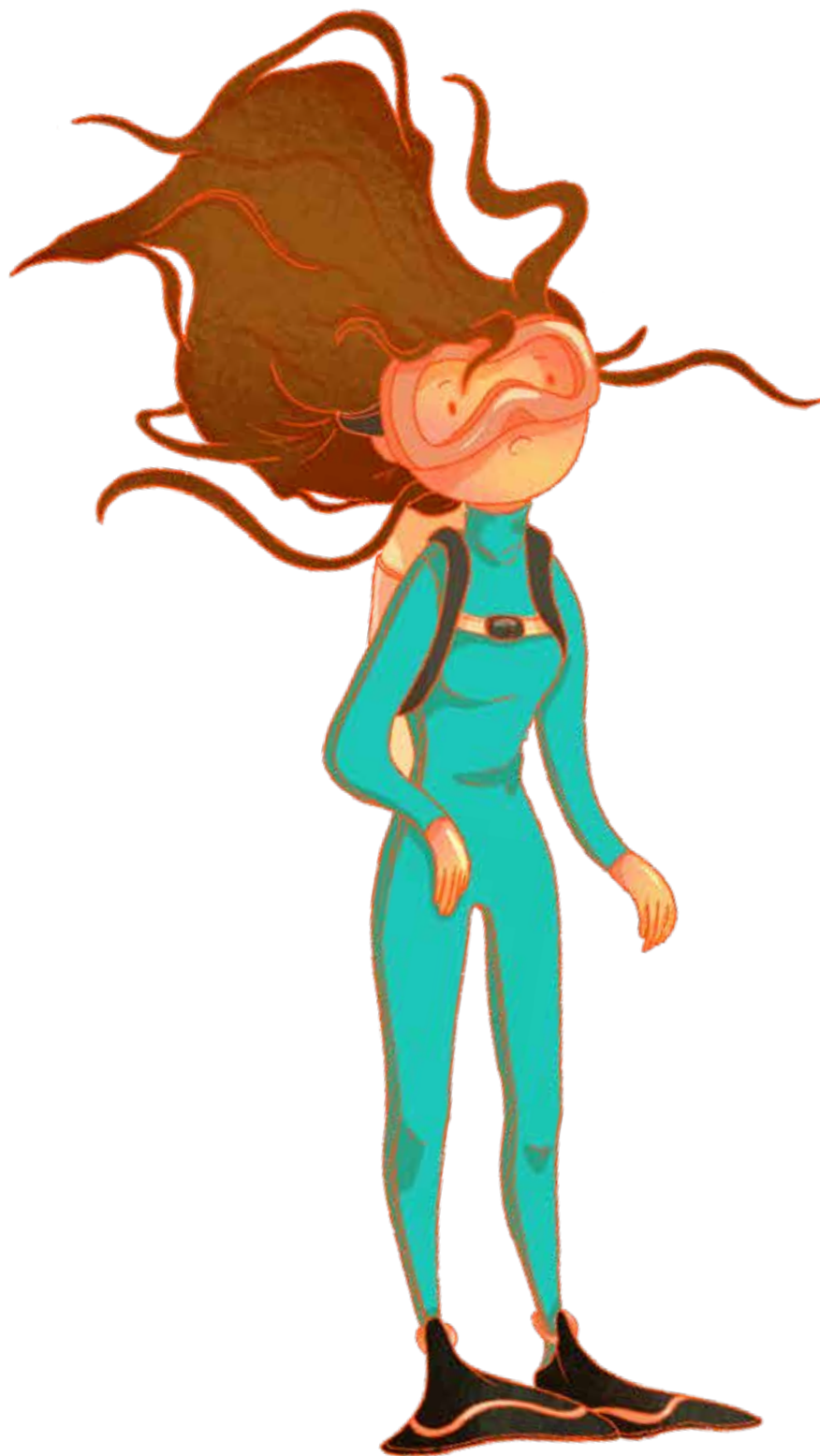



code	taille/size	descrizione/description/description	colour	euro
-	3/8" M • attacco rapido jacket • BC quick connect • connexion rapide pour stab	<ul style="list-style-type: none"> • FRUSTA JACKET/STAGNA MIFLEX XTREME tubo poliuretano, rivestimento antitaglio, 35 BAR EN250 • BC/DRY SUIT XTREME MIFLEX HOSE polyurethane tube, cut resistant coating, 35 BAR EN250 • FLEXIBLE STAB/VET ETANCHE tuyau en polyuréthane, revêtement anti-coupure, 35 BAR EN250 	-	-



50 cm	AJX0250	-	-	-	-	-	-	39,00
56 cm	AJX0256	-	-	-	-	-	-	39,50
<i>St. Mrs</i> 70 cm	AJX0260	AJX0260R	AJX0260W	AJX0260C	AJX0260V	AJX0260P	AJX0260GR	42,50
<i>St. Mrs</i> 90 cm	AJX0261	AJX0261R	AJX0261W	AJX0261C	AJX0261V	AJX0261P	AJX0261GR	47,50



code	taille/size	descrizione/description/description	colour	euro
AEX0515HD	15 cm ø 7 mm 7/16" F - 7/16" M	<ul style="list-style-type: none"> • FRUSTA HP CARBON HD MIFLEX XTREME tubo poliuretano, rivestimento antitaglio, 300 BAR EN250 • HP HOSE CARBON HD XTREME MIFLEX HOSE polyurethane tube, cut resistant coating, 300 BAR EN250 • FLEXIBLE HP CARBONE HD MIFLEX XTREME tuyau en polyuréthane, revêtement anti-coupure, 300 BAR EN250 		52,00
AEX0520HD	20 cm ø 7 mm 7/16" F - 7/16" M			53,00
AEX0560HD	60 cm ø 7 mm 7/16" F - 7/16" M			57,00
<i>St. Mrs</i> AEX0580HD	80 cm ø 7 mm 7/16" F - 7/16" M			61,00
AEX0590HD	90 cm ø 7 mm 7/16" F - 7/16" M			63,00

code	taille/size	descrizione/description/description	colour	euro
-	9/16" F - 3/8" M	<ul style="list-style-type: none"> • FRUSTA EROGATORE MIFLEX XTREME tubo poliuretano rivestimento antitaglio 35 BAR EN250 • REGULATOR HOSE XTREME MIFLEX HOSE polyurethane tube, cut resistant coating 35 BAR EN250 • FLEXIBLE DÉTENDEUR MIFLEX XTREME tuyau en polyuréthane avec revêtement anti-coupure 35 BAR EN250 	-	-



St. Mrs

St. Mrs

St. Mrs

56 cm	AEX0305	-	-	-	-	33,00
70 cm	AEX0307	-	-	-	-	34,00
80 cm	AEX0308	-	-	-	AEX0308C	35,50
90 cm	AEX0309	-	-	-	-	36,00
100 cm	AEX0310	AEX0310G	AEX0310DY	AEX0310B	AEX0310C	36,50
120 cm	AEX0312	AEX0312G	AEX0312DY	AEX0312B	-	40,00
150 cm	AEX0315	AEX0315G	-	-	-	45,50
210 cm	AEX0321	AEX0321G	-	-	-	57,50
250 cm	AEX0325	AEX0325G	-	-	-	65,00



80 cm	AEX0308R	AEX0308W	AEX0308V	AEX0308P	AEX0308GR	35,50
100 cm	AEX0310R	AEX0310W	AEX0310V	AEX0310P	AEX0310GR	36,50



code	taille/size	descrizione/description/description	colour	euro
AJ0160/1	56 cm 3/8" M	<ul style="list-style-type: none"> • FRUSTA JACKET tubo gomma , 35 BAR EN250 Ø 12 mm , attacco rapido jacket • BC HOSE rubber hose, 35 BAR EN250 Ø 12 mm, BC quick disconnect • FLEXIBLE STAB tuyau en caoutchouc, 35 BAR EN250 Ø 12 mm, connexion rapide pour stab 		39,50
AJ0160/3	60 cm 3/8" M			40,00
AJ0160	70 cm 3/8" M			41,50
AJ0161	90 cm 3/8" M			44,50



code	taille/size	descrizione/description/description	colour	euro
-	9/16" F - 3/8" M	<ul style="list-style-type: none"> • FRUSTA EROGATORE tubo gomma, 35 BAR, EN250 Ø 12 mm • REGULATOR HOSE rubber hose, 35 BAR, EN250 Ø 12 mm • FLEXIBLE DÉTENDEUR tuyau en caoutchouc, 35 BAR, EN250 Ø 12 mm 	-	-



56 cm	AE0324	32,50	-	-
60 cm	AE0322	33,50	-	-
80 cm	AE0330	36,50	-	-
100 cm	AE0340/1	40,00	AE0340	40,00
120 cm	AE0344/N	43,00	AE0344/G	43,00
150 cm	AE0345	48,50	AE0345/G	48,50
210 cm	AE0332	58,50	AE0341	58,50
250 cm	AE0331	64,00	AE0342	64,00





code	taille/size	descrizione/description/description	colour	euro
AE0349	15 cm 7/16" F - 7/16" M	<ul style="list-style-type: none"> • FRUSTA MANOMETRO tubo gomma, EN250, 1200 BAR Ø 11 mm • GAUGE HOSE rubber hose, EN250, 1200 BAR Ø 11 mm • FLEXIBLE STD MANOMETRE tuyau en caoutchouc, EN250, 1200 BAR Ø 11 mm 		31,50
AE0349/1	20 cm 7/16" F - 7/16" M			32,50
AE0310	30 cm 7/16" F - 7/16" M			35,00
AE0349/5	55 cm 7/16" F - 7/16" M			39,50
AE0349/2	60 cm 7/16" F - 7/16" M			40,50
AE0349/4	65 cm 7/16" F - 7/16" M			41,50
AE0350	80 cm 7/16" F - 7/16" M			45,00
AE0352	90 cm 7/16" F - 7/16" M			49,00
AE0353	100 cm 7/16" F - 7/16" M			50,00
AE0351	105 cm 7/16" F - 7/16" M			51,00
AE0354	120 cm 7/16" F - 7/16" M			53,00



AE0381/300



ESP100

code	taille/size	descrizione/description/description	colour	euro
AE0381/300	100 cm	<ul style="list-style-type: none"> • FRUSTA TRAVASO DIN DIN 300 BAR - tubo gomma 300 BAR, terminali in OTTONE cromato, valvola di spurgo • TANK TO TANK EQUALIZER HOSE DIN 300 BAR - rubber hose 300 BAR, plated BRASS terminals, purge valve • FLEXIBLE DE TRANSFERT DIN tuyau en caoutchouc 300 BAR, embouts en laiton chromé, soupape de purge 		223,00
ESP100	-	<ul style="list-style-type: none"> • ESPOSITORE FRUSTE metallo verniciato, 18 fruste jacket + 40 fruste erogatore • HOSE DISPLAY painted iron, suitable for 18 BC hoses + 40 regulator hoses • PRESENTOIR METALLIQUE POUR FLEXIBLES métal peint, 18 tuyau stab + 40 tuyau détenteur 		-

ENTRA NEL MONDO INCANTATO DI BEST DIVERS: **LA BELLEZZA SALVERA' IL MONDO**

ENTER THE MAGICAL WORLD OF BEST DIVERS:
BEAUTY WILL SAVE THE WORLD
ENTREZ DANS LE MONDE MAGIQUE DE BEST DIVERS:
LA BEAUTÉ SAUVERA LE MONDE





AB0775



AB0775NX



AB0778



AB0776



AB0779



code	taille/size	descrizione/description/description	colour	euro
AB0775	400 BAR Ø 45x20 mm	<ul style="list-style-type: none"> • MANOMETRO cassa OTTONE cromato, vetro plastica • PRESSURE GAUGE chrome-plated BRASS case, plastic lens • MANOMETRE LAITON chromé, lentille plastique 		63,50
AB0775NX	400 BAR Ø 45x20 mm	<ul style="list-style-type: none"> • MANOMETRO NITROX cassa OTTONE cromato, vetro plastica • NITROX PRESSURE GAUGE chrome-plated BRASS case, plastic lens • MANOMETRE NITROX LAITON chromé, lentille plastique 		
AB0778	360 BAR Ø 52X25 mm	<ul style="list-style-type: none"> • MANOMETRO cassa OTTONE cromato, vetro minerale, anello e moschettone • PRESSURE GAUGE chrome-plated BRASS case, mineral lens, ring and carabiner • MANOMETRE LAITON chromé, lentille verre + mousqueton 		96,50
AB0776	360 BAR Ø 52X25 mm	<ul style="list-style-type: none"> • MANOMETRO cassa OTTONE cromato lucido, vetro minerale • PRESSURE GAUGE chrome-plated BRASS case, mineral lens • MANOMETRE LAITON chromé, lentille verre 		90,50
AB0779	360 BAR Ø 63X25 mm	<ul style="list-style-type: none"> • MANOMETRO cassa OTTONE cromato lucido, vetro minerale • PRESSURE GAUGE chrome-plated BRASS case, mineral lens • MANOMETRE LAITON chromé, lentille verre 		87,00



AB0770



AB0770D



AB0770ST



AB0776ST



code	taille/size	descrizione/description/description	colour	euro
AB0770	400 BAR Ø 45x20 mm	<ul style="list-style-type: none"> • MANOMETRO cassa OTTONE cromato, vetro/ plastica, frusta Xtreme HP 80 cm, Ø 7 mm, clip di fissaggio • PRESSURE GAUGE chrome-plated BRASS case, plastic lens, Xtreme 80 cm HP hose, Ø 7 mm, fixing clip • MANOMETRE LAITON chromé, flexible hd xtreme 80 cm, lentille plastique 		117,00
AB0770D	360 BAR Ø 52x25 mm	<ul style="list-style-type: none"> • MANOMETRO con frusta Xtreme HP 80 cm, Ø 7 mm, cassa OTTONE cromato, vetro minerale, clip di fissaggio • PRESSURE GAUGE with Xtreme HP hose 80 cm, Ø 7 mm, chrome-plated BRASS case, mineral lens, fixing clip • MANOMETRE LAITON chromé, flexible hd extreme 80 cm, lentille verre 		144,00
AB0770ST	400 BAR Ø 45x20 mm	<ul style="list-style-type: none"> • MANOMETRO frusta gomma 80 cm, cassa OTTONE cromato, vetro plastica • PRESSURE GAUGE rubber hose 80 cm, chrome-plated BRASS case, plastic lens • MANOMETRE LAITON chromé, flexible caoutchouc 80 cm, lentille plastique 		97,00
AB0776ST	360 BAR Ø 52x25 mm	<ul style="list-style-type: none"> • MANOMETRO frusta gomma 80 cm, cassa OTTONE cromato lucido, vetro minerale • PRESSURE GAUGE rubber hose 80 cm, chrome-plated BRASS case, mineral lens • MANOMETRE LAITON chromé, flexible caoutchouc 80 cm, lentille verre 		124,00



AB0780

AB0774

AB0773

AB0777

code	taille/size	descrizione/description/description	colour	euro
AB0780	400 BAR	<ul style="list-style-type: none"> • MANOMETRO DI SUPERFICIE filetto DIN 300 BAR • SURFACE PRESSURE GAUGE 300 BAR DIN thread • “TOP” MANOMETRE DE SURFACE 300 BAR 		81,50
AB0774	400 BAR	<ul style="list-style-type: none"> • MANOMETRO DI SUPERFICIE bagno d'olio, filetto DIN 300 BAR • SURFACE PRESSURE GAUGE oil filled, 300 BAR DIN thread • MANOMETRE bain d'huile, filetage DIN 300 BAR 		134,50
AB0773	Ø 40X25 mm	<ul style="list-style-type: none"> • MANOMETRO bassa pressione 25 BAR, innesto rapido jacket • PRESSURE GAUGE low pressure 25 BAR, quick connect to BC • MANOMETRE MP basse pression 25 BAR, connexion rapid stab 		43,00
AB0777	350 BAR Ø 26x15 mm 50 m	<ul style="list-style-type: none"> • MINI MANOMETRO per primo stadio • MINI PRESSURE GAUGE for 1st stage • MINI MANOMETRE premier etage 		34,50

St. Mrs



JTS091



JTS091/B



AB0768N



AB0768G



AB0768V



code	taille/size	descrizione/description/description	colour	euro
JTS091	-	<ul style="list-style-type: none"> • BUSSOLA da polso • COMPASS wrist compass • BOUSSOLE poignet 		73,00
JTS091/B	-	<ul style="list-style-type: none"> • BUSSOLA BUNGEE da polso con elastici • BUNGEE COMPASS wrist compass with bungee cords • BOUSSOLE poignet + bungee 		75,00
AB0768N	Ø 45 X 20 mm	<ul style="list-style-type: none"> • GUSCIO MANOMETRO protezione manometro • GAUGE COVER gauge protection • BOITIER MANOMETRE 		8,5
AB0768V				
AB0768G				



	code	taille/size	descrizione/description/description	colour	euro
DESIGN	AI0901	21x38 cm, 1L close, 1L open	<ul style="list-style-type: none"> • SACCO STAGNO PVC piatta • PVC DRY BAG flat • SAC ÉTANCHE plat • SACCO STAGNO PVC • PVC DRY BAG • SAC ÉTANCHE • SACCO STAGNO PVC con tracolla • PVC DRY BAG with shoulder strap • SAC ÉTANCHE avec bretelles 		13,00
DESIGN	AI0907	Ø 15x23 cm, 3L close, 4L open			16,50
DESIGN	AI0905	Ø 15x40 cm, 5L close, 7L open			19,50
DESIGN	AI0908	Ø 21x37 cm, 10L close, 13L open			25,00
DESIGN	AI0916	Ø 22x45 cm, 15L close, 17L open			26,50
DESIGN	AI0917	Ø 30x70 cm, 40L close, 49L open			40,00



	code	taille/size	descrizione/description/description	colour	euro
DESIGN	AI0918	Ø 30x90 cm 60L close, 64L open	<ul style="list-style-type: none"> • SACCO STAGNO PVC con tracolla • PVC DRY BAG with shoulder strap • SAC ÉTANCHE avec bretelles 		55,00
DESIGN	AI0918T	Ø 40x75 cm 90L close, 95L open			75,50



	code	taille/size	descrizione/description/description	colour	euro
DESIGN	AI0908N	Ø 21x37 cm, 10L close, 13L open	<ul style="list-style-type: none"> • SACCO STAGNO PVC con tracolla • PVC DRY BAG with shoulder strap • SAC ÉTANCHE avec bretelles 		25,00
DESIGN	AI0916N	Ø 22x45 cm, 15L close, 17L open			26,50
DESIGN	AI0917N	Ø 30x70 cm, 40L close, 49L open			40,00
DESIGN	AI0918N	Ø 30x90 cm, 60L close, 64L open			55,00

• NB I prodotti con la scritta waterproof/étanche/stagno/dry, sono da intendersi resistenti agli spruzzi d'acqua e non idonei all'immersione.
 • NB Products marked waterproof/étanche/tin/dry are intended as splash-proof and are not suitable for immersion.
 • NB Products marked waterproof/étanche/tin/dry are intended as splash-proof and not suitable for immersion.



	code	taille/size	descrizione/description/description	colour	euro
DESIGN	AI0908G	Ø 21x37 cm, 10L close, 13L open	<ul style="list-style-type: none"> • SACCO STAGNO PVC con tracolla • PVC DRY BAG with shoulder strap • SAC ÉTANCHE avec bretelles 		25,00
DESIGN	AI0916G	Ø 22x45 cm, 15L close, 17L open			26,50
DESIGN	AI0917G	Ø 30x70 cm, 40L close, 49L open			40,00



	code	taille/size	descrizione/description/description	colour	euro
DESIGN	AI0908P	Ø 21x37 cm, 10L close, 13L open	<ul style="list-style-type: none"> • SACCO STAGNO PVC con tracolla • PVC DRY BAG with shoulder strap • SAC ÉTANCHE avec bretelles 		25,00
DESIGN	AI0916P	Ø 22x45 cm, 15L close, 17L open			26,50
DESIGN	AI0917P	Ø 30x70 cm, 40L close, 49L open			40,00



	code	taille/size	descrizione/description/description	colour	euro
DESIGN	AI0908MI	Ø 21x37 cm, 10L close, 13L open	<ul style="list-style-type: none"> • SACCO STAGNO PVC con tracolla • PVC DRY BAG with shoulder strap • SAC ÉTANCHE avec bretelles 		25,00
St. Mrs	AI0916MI	Ø 22x45 cm, 15L close, 17L open			26,50
DESIGN	AI0917MI	Ø 30x70 cm, 40L close, 49L open			40,00
DESIGN	AI0918MI	Ø 30x90 cm, 60L close, 64L open			55,00

• NB I prodotti con la scritta waterproof/étanche/stagno/dry, sono da intendersi resistenti agli spruzzi d'acqua e non idonei all'immersione.
 • NB Products marked waterproof/étanche/tin/dry are intended as splash-proof and are not suitable for immersion.
 • NB Products marked waterproof/étanche/tin/dry are intended as splash-proof and not suitable for immersion.



	code	taille/size	descrizione/description/description	colour	euro
DESIGN St. Mrs	AI09190R	40L Ø 30x68 cm	<ul style="list-style-type: none"> • ZAINO STAGNO PVC con spallacci imbottiti • PVC DRY BACKPACK with padded shoulder straps • SAC A DOS ÉTANCHE avec bretelles rembourrées 		85,50
DESIGN St. Mrs	AI0919BK				
DESIGN St. Mrs	AI0919MI				



AI0918T

	code	taille/size	descrizione/description/description	colour	euro
DESIGN	BH0950	115L 40x20x110 cm	<ul style="list-style-type: none"> • ZAINO STAGNO "TERMINATOR" PVC, spallacci, maniglia trasporto • DRY BACKPACK "TERMINATOR" PVC, shoulder straps, handle • SAC A DOS ÉTANCHE "TERMINATOR" PVC, spallacci, maniglia trasporto 		72,00

• NB I prodotti con la scritta waterproof/étanche/stagno/dry, sono da intendersi resistenti agli spruzzi d'acqua e non idonei all'immersione.
 • NB Products marked waterproof/étanche/tin/dry are intended as splash-proof and are not suitable for immersion.
 • NB Products marked waterproof/étanche/tin/dry are intended as splash-proof and not suitable for immersion.



AI0982

AI0981

AI0980

BEST DIVERS
microattrezzatura

code	taille/size	descrizione/description/description	colour	euro
AI0982	<ul style="list-style-type: none"> • chiusa • closed • fermé 30x35 cm • aperta • open • ouvert 41x30 cm 	<ul style="list-style-type: none"> • BUSTA STAGNA porta documenti, cellulare, chiavi • WATERPROOF BAG document holder, keys • POCHETTE ÉTANCHE porte-documents, téléphone portable, clés 		21,00
AI0981	<ul style="list-style-type: none"> • chiusa • closed • fermé 24x21 cm • aperta • open • ouvert 31x21 cm 			15,50
AI0980	<ul style="list-style-type: none"> • chiusa • closed • fermé 10x13 cm • aperta • open • ouvert 20,15x13 cm 			12,50



AI0300M



AI0300



AI0301

code	taille/size	descrizione/description/description	colour	euro
St. Mrs AI0300M	Ø 5x10 cm	<ul style="list-style-type: none"> • UOVO STAGNO con chiusura a vite, mini • MINI DRY BOX with screw cap, mini • BOITE ÉTANCHE avec fermeture vissee, mini 		14,50
St. Mrs AI0300	Ø 4,5x12 cm	<ul style="list-style-type: none"> • UOVO STAGNO PICCOLO con chiusura a vite, piccolo • DRY BOX with screw cap, small • BOITE ÉTANCHE avec fermeture vissee, petit 		29,50
St. Mrs AI0301	Ø 5,5x18 cm	<ul style="list-style-type: none"> • UOVO STAGNO con chiusura a vite, grande • DRY BOX with screw cap, big • BOITE ÉTANCHE avec fermeture vissee, grande 		30,00



CB161007



CB211106



CB161007B

code	taille/size	descrizione/description/description	colour	euro
CB161007	210x107x48 mm	<ul style="list-style-type: none"> • CRISTAL BOX waterproof • CRISTAL BOX waterproof • BOITE CRYSTAL étanche 		33,50
CB211106				
CB161007B				

• NB I prodotti con la scritta waterproof/étanche/stagno/dry, sono da intendersi resistenti agli spruzzi d'acqua e non idonei all'immersione.
 • NB Products marked waterproof/étanche/tin/dry are intended as splash-proof and are not suitable for immersion.
 • NB Products marked waterproof/étanche/tin/dry are intended as splash-proof and not suitable for immersion.

NEW



AI0893

NEW



AI0894

code	taille/size	descrizione/description/description	colour	euro
AI0893	21x11 cm	<ul style="list-style-type: none"> • PORTACELLULARE "AIR BUBBLE" waterproof • DRY PHONE BAG "AIR BUBBLE" waterproof • PORTE TÉLÉPHONE "AIR BUBBLE" étanche 		11,00
AI0894	21x11 cm • banda elastica • elastic bandage • bandes elastiques	<ul style="list-style-type: none"> • PORTACELLULARE waterproof • DRY PHONE BAG waterproof • PORTE TÉLÉPHONE étanche 		



AI6000



AI4000



AI5500



AI3000



AI5000

	code	taille/size	descrizione/description/description	colour	euro
St. Mrs	AI6000	-	<ul style="list-style-type: none"> • OYSTER BOX "MASK" custodia studiata per riporre la maschera, termoformata, imbottitura antiurto • OYSTER BOX "MASK" case for mask, thermoformed, shockproof padding • OYSTER BOX "MASK" étui conçu pour le rangement des masques, thermoformé, rembourré 	 	22,50
St. Mrs	AI3000	Ø 10x7 cm	<ul style="list-style-type: none"> • OYSTER BOX "S" misura piccola, TONDO, contenitore termoformato, imbottitura antiurto, per strumenti, computer, torce • OYSTER BOX "S" small size, ROUND, thermoformed case, shockproof padding, for gauges, computers, lights • OYSTER BOX "S" petit format, rond, conteneur thermoformé, rembourrage antichoc, pour instruments, ordinateurs, torches 	 	15,00
St. Mrs	AI4000	13x10x7 cm	<ul style="list-style-type: none"> • OYSTER BOX "M" misura media, OVALE, contenitore termoformato, imbottitura antiurto, per strumenti: macchine fotografiche, computer, torce • OYSTER BOX "M" small size, OVAL, thermoformed case, shockproof padding, for gauges, computers, lights, digital cameras • OYSTER BOX "M" taille moyenne, OVAL, conteneur thermoformé, rembourrage antichoc, pour instruments : caméras, ordinateurs, torches 	 	16,50
St. Mrs	AI5000	20x10x7 cm	<ul style="list-style-type: none"> • OYSTER BOX "L" misura grande, OVALE, contenitore termoformato, imbottitura antiurto, per strumenti: macchine fotografiche, computer, torce • OYSTER BOX "L" big size, OVAL, thermoformed case, shockproof padding, for gauges, computers, lights, digital cameras • OYSTER BOX "L" grande taille, OVAL, conteneur thermoformé, rembourrage antichoc, pour les instruments : caméras, ordinateurs, torches 	 	17,50
St. Mrs	AI5500	12x12x8 cm	<ul style="list-style-type: none"> • OYSTER BOX "CUBE" custodia quadrata, termoformata, imbottitura antiurto • OYSTER BOX "CUBE" square case, thermoformed, shockproof padding • OYSTER BOX "CUBE" valise carrée, thermoformée, rembourrage anti-chocs 	 	21,00

• NB I prodotti con la scritta waterproof/étanche/stagno/dry, sono da intendersi resistenti agli spruzzi d'acqua e non idonei all'immersione.
 • NB Products marked waterproof/étanche/tin/dry are intended as splash-proof and are not suitable for immersion.
 • NB Products marked waterproof/étanche/tin/dry are intended as splash-proof and not suitable for immersion.



code	taille/size	descrizione/description/description	colour	euro
CBDS01	150x82x41 mm	<ul style="list-style-type: none"> • BLACK BOX waterproof, senza spugna • BLACK BOX waterproof, without foam • VALISE étanche sans éponge 	■	21,00
CBDS02	212x140x47 mm		■	28,00
CBDS03	316x195x81 mm		■	41,50



code	taille/size	descrizione/description/description	colour	euro
CBDS505	500x350x194 mm	<ul style="list-style-type: none"> • BLACK BOX waterproof, senza spugna • BLACK BOX waterproof, without foam • VALISE étanche sans éponge 	■	180,50
CBDS235	235x180x156 mm		■	59,50
CBSP505	for 505	• SPUGNA CUBETTATA • FOAM • CUBE DE MOUSSE	■	19,00
CBSP235	for 235	• SPUGNA CUBETTATA • FOAM • CUBE DE MOUSSE	■	7,50



code	taille/size	descrizione/description/description	colour	euro
MUB78	807x470x345 mm	<ul style="list-style-type: none"> • EXPLORE CASE waterproof • EXPLORE CASE waterproof • CAISSE ÉTANCHE EXPLORER MUB 	■	189,50
TR070	39x28x63-101 cm portata/breaking point 65 kg	<ul style="list-style-type: none"> • CARRELLO BOMBOLA struttura in ALLUMINIO, manico regolabile a tre altezze, ripiegabile, ruote poliuretano • FOLDABLE HANDTRUCK ALUMINIUM structure, three lengths adjustable handle, poliurethane wheels • DIABLE PLIANT cadre en aluminium, poignée réglable à trois hauteurs, pliable, roues en polyuréthane 	■ ■	62,00

• NB I prodotti con la scritta waterproof/étanche/stagno/dry sono da intendersi resistenti agli spruzzi d'acqua e non idonei all'immersione.
 • NB Products marked waterproof/étanche/tin/dry are intended as splash-proof and are not suitable for immersion.
 • NB Products marked waterproof/étanche/tin/dry are intended as splash-proof and not suitable for immersion.



AR0953CV



AR0953CB



AR0953SK



code	taille/size	descrizione/description/description	colour	euro
AR0953CV	Ø 29x15 cm • TONDO • ROUND • RONDE	• BORSELLO PORTA EROGATORE non imbottito • REGULATOR BAG not padded • SACOCHÉ DÉTENDEUR sans rembourrage		33,00
AR0953CB				
AR0953SK				



AR0953BD



AR0953DV



AR0953KC



code	taille/size	descrizione/description/description	colour	euro
AR0953BD	Ø 29x15 cm • TONDO • ROUND • RONDE	• BORSELLO PORTAEROGATORE non imbottito • REGULATOR BAG not padded • SACOCHÉ DÉTENDEUR sans rembourrage		33,00
AR0953DV				
AR0953KC				



AR0954CV



AR0954CB



AR0954BP



code	taille/size	descrizione/description/description	colour	euro
AR0954CV	34x25x12 cm • RETTANGOLARE • RECTANGULAR • RECTANGULAIRE	• BORSELLO PORTAEROGATORE non imbottito • REGULATOR BAG not padded • SACOCHÉ DÉTENDEUR sans rembourrage		33,50
AR0954CB				
AR0954BP				



AR0954BD



AR0954YS



AR09540P

code	taille/size	descrizione/description/description	colour	euro
AR0954BD	34x25x12 cm • RETTANGOLARE • RECTANGULAR • RECTANGULAIRE	<ul style="list-style-type: none"> • BORSELLO PORTAEROGATORE non imbottito • REGULATOR BAG not padded • SACOCHE DETENDEUR sans rembourrage 		33,50
AR0954YS				
AR09540P				



AV0915



code	taille/size	descrizione/description/description	colour	euro
AV0915	Ø 40x72 cm	<ul style="list-style-type: none"> • BORSA A RETE GHOST maniglie, richiudibile su se stessa • GHOST NET BAG with handles, closable • SAC FILET FANTOME poignées, repliables sur elles-mêmes 		40,50



AI0915B



AI0915XL



code	taille/size	descrizione/description/description	colour	euro
AI0915XL	100x35 cm	<ul style="list-style-type: none"> • SACCA A RETE "EXTRA LONG" poliestere, chiusura superiore con laccetto • NET BAG "EXTRA LONG" polyester, upper closure with strap • SAC FILET DE TRANSPORT "EXTRA LONG" polyester, fermeture supérieure par cordon de serrage 		14,50
AI0915B	70x30 cm	<ul style="list-style-type: none"> • SACCA A RETE "EXTRA" poliestere, chiusura superiore con laccetto • NET BAG "EXTRA" polyester, upper closure with strap • SAC FILET DE TRANSPORT "EXTRA" polyester, fermeture supérieure par cordon de serrage 		12,50



JTS059



JTS066



TK0928



JTS071



code	taille/size	descrizione/description/description	colour	euro
JTS059	15x10x7 cm capacità/capacity 500/1000 gr	<ul style="list-style-type: none"> • TASCA PORTA PIOMBI PICCOLA sgancio rapido, chiusura velcro, fondo rinforzato • SMALL WEIGHT POCKET quick release system, velcro clousure, reinforced bottom • PETITE POCHE A LEST à ouverture rapide, fermeture velcro, fond renforcé 	■	37,00
JTS066	20x13x7 cm capacità/capacity 500/3000 gr	<ul style="list-style-type: none"> • TASCA PORTA PIOMBI GRANDE sgancio rapido, chiusura velcro, fondo rinforzato • BIG WEIGHT POCKET quick release system, velcro clousure, reinforced bottom • GRANDE POCHE A LEST à ouverture rapide, fermeture velcro, fond renforcé 	■	38,50
TK0928	22x14x4 cm	<ul style="list-style-type: none"> • DECO POCKET polyester 600, tasca da gamba per finger reel e boa decompressione, elastici di fissaggio • DECO POCKET leg pocket for finger reel and decompression buoy, elastic fixings • POCHETTE PARACHUTE polyester 600, poche sur la jambe pour l'enrouleur et la bouée ddécompression, fermetures élastiques 	■	40,50
JTS071	19x17x6 cm	<ul style="list-style-type: none"> • TASCA PORTA PIOMBI universale, (la coppia) • WEIGHT POCKET universal, (per pair) • POCHES PORTE LEST universelle, (la paire) 	■	85,50



JTS070



JTS069



JTS074



code	taille/size	descrizione/description/description	colour	euro
JTS070	chiusa 14,5x9,5 cm aperta 25x14,5 cm	<ul style="list-style-type: none"> • TASCA EMERGENZA srotolabile • EMERGENCY POCKET unrollable • POCHES SECURITE enroulable 	■	29,50
JTS069	24x15x6,5 cm	<ul style="list-style-type: none"> • TASCA DA GAMBA universale • LEG POCKET universal • POCHES JAMBE universelle 	■	41,00
JTS074	34x13x4,5 cm	<ul style="list-style-type: none"> • TASCA DA BOMBOLA • TANK POCKET • POCHES BOUTEILLE 	■	38,50



code	taille/size	descrizione/description/description	colour	euro
BH0941	32x125 cm	<ul style="list-style-type: none"> • BORSA PORTA FUCILI CORTA POLY 600, 670 gr tracolla, chiusura superiore • SHORT SPEAR GUN BAG POLY 600, 670 gr shoulder strap, top closure • SAC POLYBAG ARBALETE POLY 600, 670 gr bandoulière, fermeture supérieure 		47,50
BH0941R				
BH09410				



code	taille/size	descrizione/description/description	colour	euro
BH0943	32x115 cm	<ul style="list-style-type: none"> • BORSA PORTA PINNE POLY 600, 500 gr tracolla, chiusura superiore • FIN BAG POLY 600, 500 gr shoulder strap, top closure • SAC PALMES POLY 600, 500 gr bandoulière, fermeture supérieure 		40,00
BH0943R				
BH09430				



code	taille/size	descrizione/description/description	colour	euro
BH0940	133x22 cm	<ul style="list-style-type: none"> • BORSA PORTA OLEOPNEUMATICO • BAG FOR AIRGUN • SAC FUSIL PNEUMATIQUE 		35,00
AV0600	88x58 cm	<ul style="list-style-type: none"> • BORSA PORTA MUTA borsa NYLON per trasporto muta, utilizzabile anche come tappetino • SUIT/MAT BAG NYLON bag for wetsuit, can be used as mat • SAC TAPIS/VETEMENT ETANCHE sac en NYLON pour le transport des combinaisons de plongée, peut également être utilisé comme tapis 		42,00

ENTRA NEL MONDO INCANTATO DI BEST DIVERS: **QUANDO HAI CHIARO L'OBIETTIVO FAI GOAL**

ENTER THE MAGICAL WORLD OF BEST DIVERS:



WHEN YOU ARE CLEAR ABOUT THE TARGET YOU SCORE A GOAL

ENTREZ DANS LE MONDE MAGIQUE DE BEST DIVERS:



LORSQUE VOUS ÊTES CLAIR SUR L'OBJECTIF, VOUS MARQUEZ UN BUT





	code	taille/size	descrizione/description/description	colour	euro
St. Mrs	A10666	1 kg	<ul style="list-style-type: none"> • ELENY piombo gommato • ELENY coated rubber weight • ELENY plomb caoutchouté 		19,50
St. Mrs	A10666/D	0,5 kg			14,00
St. Mrs	A10665	1 kg	<ul style="list-style-type: none"> • ELENY piombo gommato • ELENY coated rubber weight • ELENY plomb caoutchouté 		19,50
St. Mrs	A10665/D	0,5 kg			14,00



	code	taille/size	descrizione/description/description	colour	euro
	A10661	1 kg	<ul style="list-style-type: none"> • BLACK GRIP piombo gommato • BLACK GRIP coated rubber weight • BLACK GRIP plomb caoutchouté 		16,00
	A10661/A	2 kg			32,50
	A10660	1 kg	<ul style="list-style-type: none"> • YELLOW GRIP piombo gommato • YELLOW GRIP coated rubber weight • YELLOW GRIP plomb caoutchouté 		16,00
	A10660/A	2 kg			32,50
	A10661M	1 kg	<ul style="list-style-type: none"> • CAMO GRIP piombo gommato • CAMO GRIP coated rubber weight • CAMO GRIP plomb caoutchouté 		16,00
	A10661/A-M	2 kg			32,50



	code	taille/size	descrizione/description/description	colour	euro
St. Mrs	A10647/D	0,5 kg	<ul style="list-style-type: none"> • PIOMBO GREZZO STANDARD passanti a 3 barre • STANDARD LEAD WEIGHT 3 bar loop • PLOMB STD boucles à 3 barres 		7,50
St. Mrs	A10647	1 kg			9,00
St. Mrs	A10647/A	2 kg			16,50
St. Mrs	A10647/E	2,5 kg			23,50
St. Mrs	A10662/D	0,5 kg	<ul style="list-style-type: none"> • PIOMBO ULTRASOFT sacchetto a rete pallini in piombo nichelati • ULTRASOFT WEIGHT net bag nickel plated lead shots • PLOMB GRENAILLE sac en filet grenaille de plomb nickelée 		10,50
St. Mrs	A10662	1 kg			15,50
St. Mrs	A10662/A	2 kg			28,50
St. Mrs	A10662/E	2,5 kg			35,00
St. Mrs	A10662/G	3 kg			40,00



BH0300



BH0305



BH0300M



AI0113

code	taille/size	descrizione/description/description	colour	euro
St. Mrs BH0300	Ø 15x70 mm 300 gr, 1 pc	<ul style="list-style-type: none"> • PEDAGNO da utilizzare con boe segnalazione e pedagni decompressione • DROP WEIGHT to be used with signalling and deco buoys • PLOMB DE PARACHUTE à utiliser avec les bouées de signalisation et les parachute de palier 		11,00
St. Mrs BH0300/1	Ø 15x70 mm 300 gr, 20 pcs bulk			-
BH0305	Ø 15x70 mm 300 gr, 1 pc	<ul style="list-style-type: none"> • PEDAGNO PIOMBO PLASTIFICATO da utilizzare con boe segnalazione e pedagni decompressione • LAMINATED LEAD DROP WEIGHT to be used with signalling and deco buoys • PLOMB PARACHUTE à utiliser avec les bouées de signalisation et les parachute de palier 		12,00
BH0300P	Ø 15x70 mm 300 gr, 20 pcs bulk			-
BH0300M	Ø 15x70 mm 300 gr, 1 pc	<ul style="list-style-type: none"> • PEDAGNO PIOMBO PLASTIFICATO da utilizzare con boe segnalazione e pedagni decompressione • LAMINATED LEAD DROP WEIGHT to be used with signalling and deco buoys • PLOMB PARACHUTE à utiliser avec les bouées de signalisation et les parachute de palier 		12,00
BH0300PM	Ø 15x70 mm 300 gr, 20 pcs bulk			-
AI0113	Ø 15x70 mm 30 gr, 1 pc	<ul style="list-style-type: none"> • ROCCHETTO NYLON avvolgisagola • NYLON LINE HOLDER line holder • LEST NYLON bobine 		7,00

BH0700
500 gr



BH0710
1000 gr

BH400N



BH400M

code	taille/size	descrizione/description/description	colour	euro
BH0700	500 gr 80x80x8 mm	<ul style="list-style-type: none"> • MATTONELLA PIOMBO plastificata • "TILE WEIGHT" laminated • TUILE plastifié 		11,50
BH0710	1 kg 80x80x15 mm			
BH0400N	750 gr	<ul style="list-style-type: none"> • PEDAGNO gancio rapido, plastificato • WEIGHT quick release, laminated • LESTAGE RAPIDE plastifié 		23,00
BH0400M				



BH0450G



code	taille/size	descrizione/description/description	colour	euro
St. Mrs BH0450G	600 gr	<ul style="list-style-type: none"> • PEDAGNO "GRANCHIO" con anello inox • DROP WEIGHT "GRANCHIO" with inox clip • LESTAGE RAPID "GRANCHIO" avec anneau en inox 		21,00



	code	taille/size	descrizione/description/description	colour	euro
St. Mrs	AI0662/300	300 gr	<ul style="list-style-type: none"> • CAVIGLIERA ULTRASOFT pallini nichelati, cinturino elastico, chiusura a clip, (singola) • ULTRASOFT ANKLE WEIGHT nickel plated lead shots, elastic strap with clip, (single) • SACHET GRENAILLE CHEVILLE grenaille nickelée, sangle élastique, fermeture par clip (single) 		14,00
St. Mrs	AI0662/500	500 gr			17,50
St. Mrs	AI0662/1000	1 kg			28,50
	AI0664/500	500 gr	<ul style="list-style-type: none"> • CAVIGLIERE NEOPRENE pallini nichelati, neoprene elastico, chiusura velcro, (la coppia) • NEOPRENE ANKLE WEIGHTS nickel plated lead shots, elastic neoprene, velcro strap (couple) • SACHET NEO PREFORME CHEVILL grenaille nickelée, neoprene élastique, fermeture par clip (paire) 	■	34,50
	AA0647	500 gr	<ul style="list-style-type: none"> • CAVIGLIERE SAGOMATE copertura neoprene, chiusura velcro (coppia) • SHAPED ANKLE WEIGHTS neoprene covered, velcro strap (couple) • SACHET NEO PREFORME CHEVILLE housse en néoprène, fermeture velcro (paire) 		43,50
	AA0647P	500 gr	<ul style="list-style-type: none"> • CAVIGLIERE SAGOMATE cavigliera plastificata, (singola) • SHAPED ANKLE WEIGHTS laminated ankle weight, (single) • POIDS CHEVILLE bracelet de cheville plastifié (single) 		11,00



	code	taille/size	descrizione/description/description	colour	euro
	AV0650	28,5x24x13 cm	<ul style="list-style-type: none"> • PORTA PIOMBI pratica borsa a rete drenante per il trasporto dei piombi • WEIGHT NET BAG quick-drying weight net bag • SAC A PLOMBS sac pratique en filet drainant pour le transport des plombs 	■	39,00
	AV0650A			■	



ZI0130



ZI0130I



ZI0130B



ZI0130S

code	taille/size	descrizione/description/description	colour	euro
ZI0130	150x 50 mm	<ul style="list-style-type: none"> • CINTURA STANDARD cintura per zavorra, fibbia NYLON • STANDARD WEIGHT BELT, NYLON buckle • CEINTURE STANDARD boucle plastique 		14,50
ZI0130I	150x 50 mm • standard	<ul style="list-style-type: none"> • CINTURA STANDARD cintura per zavorra, fibbia INOX • STANDARD WEIGHT BELT, S.STEEL buckle • CEINTURE STANDARD boucle en acier inoxydable 		16,50
ZI0130B	150x 50 mm • balena • whale • baleine			
ZI0130S	150x 50 mm • squalo • shark • requin			



ZI0140



ZI0140I



ZI0140B



ZI0140S

code	taille/size	descrizione/description/description	colour	euro
ZI0140	150x 50 mm	<ul style="list-style-type: none"> • CINTURA STANDARD cintura per zavorra, fibbia NYLON • STANDARD WEIGHT BELT, NYLON buckle • CEINTURE STANDARD boucle plastique 		14,50
ZI0140I	150x 50 mm • standard	<ul style="list-style-type: none"> • CINTURA STANDARD cintura per zavorra, fibbia INOX • STANDARD WEIGHT BELT, S.STEEL buckle • CEINTURE STANDARD boucle en acier inoxydable 		16,50
ZI0140B	150x 50 mm • balena • whale • baleine			
ZI0140S	150x 50 mm • squalo • shark • requin			



ZI0160



ZI0160I



ZI0160B



ZI0160S

code	taille/size	descrizione/description/description	colour	euro
ZI0160	150x 50 mm	<ul style="list-style-type: none"> • CINTURA STANDARD cintura per zavorra, fibbia NYLON • STANDARD WEIGHT BELT, NYLON buckle • CEINTURE STANDARD boucle plastique 		14,50
ZI0160I	150x 50 mm • standard	<ul style="list-style-type: none"> • CINTURA STANDARD cintura per zavorra, fibbia INOX • STANDARD WEIGHT BELT, S.STEEL buckle • CEINTURE STANDARD boucle en acier inoxydable 		16,50
ZI0160B	150x 50 mm • balena • whale • baleine			
ZI0160S	150x 50 mm • squalo • shark • requin			



ZI0150



ZI0150I



ZI0150B



ZI0150S

code	taille/size	descrizione/description/description	colour	euro
ZI0150	150x 50 mm	<ul style="list-style-type: none"> • CINTURA STANDARD cintura per zavorra, fibbia NYLON • STANDARD WEIGHT BELT, NYLON buckle • CEINTURE STANDARD boucle plastique 		14,50
ZI0150I	150x 50 mm • standard	<ul style="list-style-type: none"> • CINTURA STANDARD cintura per zavorra, fibbia INOX • STANDARD WEIGHT BELT, S.STEEL buckle • CEINTURE STANDARD boucle en acier inoxydable 		16,50
ZI0150B	150x 50 mm • balena • whale • baleine			
ZI0150S	150x 50 mm • squalo • shark • requin			



ZI0170



ZI0170I



ZI0170B



ZI0170S

code	taille/size	descrizione/description/description	colour	euro
ZI0170	150x 50 mm	<ul style="list-style-type: none"> • CINTURA STANDARD cintura per zavorra, fibbia NYLON • STANDARD WEIGHT BELT, NYLON buckle • CEINTURE STANDARD boucle plastique 		14,50
ZI0170I	150x 50 mm • standard	<ul style="list-style-type: none"> • CINTURA STANDARD cintura per zavorra, fibbia INOX • STANDARD WEIGHT BELT, S.STEEL buckle • CEINTURE STANDARD boucle en acier inoxydable 		16,50
ZI0170B	150x 50 mm • balena • whale • baleine			
ZI0170S	150x 50 mm • squalo • shark • requin			



code	taille/size	descrizione/description/description	colour	euro
R050N	50 mm, 50 m	<ul style="list-style-type: none"> • NASTRO IN ROLOLO nastro polipropilene • BAND ROLL polypropilene band • SANGLE rouleau de polypropylène 		2,40/m
R050G	50 mm, 50 m			
R050F	50 mm, 50 m			
R050B	50 mm, 50 m			
R050A	50 mm, 50 m			



BH0078N



BH0078



BH0079

code	taille/size	descrizione/description/description	colour	euro
St. Mrs BH0078N	140x50 mm	<ul style="list-style-type: none"> • CINTURA GOMMA cintura gomma, fibbia NYLON • RUBBER BELT nylon buckle • CEINTURE EN CAOUTCHOUC boucle en Nylon 	■	19,00
St. Mrs BH0078		<ul style="list-style-type: none"> • CINTURA GOMMA cintura gomma, fibbia INOX • RUBBER BELT S.STEEL buckle • CEINTURE EN CAOUTCHOUC boucle en en acier inoxydable 		20,00
BH0079	138x4,5 cm	<ul style="list-style-type: none"> • CINTURA MARSIGLIESE cintura gomma a sgancio rapido, fibbia INOX • MARSEILLESE BELT quick release rubber belt, S.STEEL buckle • CEINTURE MARSEILLAISE ceinture en caoutchouc à dégagement rapide, boucle en acier inoxydable 		39,00



BH0080N



BH0080



BH0078W



BH0078NW



code	taille/size	descrizione/description/description	colour	euro
BH0080N	140x50 mm	<ul style="list-style-type: none"> • CINTURA GOMMA cintura gomma, fibbia NYLON • RUBBER BELT nylon buckle • CEINTURE EN CAOUTCHOUC boucle en Nylon 	■	19,50
BH0080		<ul style="list-style-type: none"> • CINTURA GOMMA cintura gomma, fibbia INOX • RUBBER BELT S.STEEL buckle • CEINTURE EN CAOUTCHOUC boucle en acier inoxydable 		21,50
St. Mrs BH0078W	140x50 mm	<ul style="list-style-type: none"> • CINTURA GOMMA cintura gomma, fibbia INOX • RUBBER BELT S.STEEL buckle • CEINTURE EN CAOUTCHOUC boucle en acier inoxydable 		□
St. Mrs BH0078NW		<ul style="list-style-type: none"> • CINTURA GOMMA cintura gomma, fibbia NYLON • RUBBER BELT nylon buckle • CEINTURE EN CAOUTCHOUC boucle en Nylon 	22,00	



NEW



code	taille/size	descrizione/description/description	colour	euro
R078W	50 mm, 45 m	<ul style="list-style-type: none"> • NASTRO IN ROTOLO gomma • BAND ROLL rubber • SANGLE caoutchouc 	□	12,00/m
R078M	50 mm, 45 m		■	10,50/m
R078N	50 mm, 50 m		■	8,00/m



FI100



FI102Q



FI106







FI105



FI102



code	taille/size	descrizione/description/description	colour	euro
FI100	50 mm, 1 pc	<ul style="list-style-type: none"> • FIBBIA NYLON fissaggio a 3 barre • NYLON BUCKLE 3 bar loop • BOUCLE PLASTIQUE 3 barres 		7,50
FI100/25	50 mm, 25 pcs			-
FI102Q	50 mm, 1 pc	<ul style="list-style-type: none"> • FIBBIA QUADRA INOX fissaggio a 3 barre • SQUARE S.STEEL BUCKLE 3 bar loop • BOUCLE INOX 3 barres 		10,00
FI102Q/25	50 mm, 25 pcs			-
FI106	50 mm, 1 pc	<ul style="list-style-type: none"> • FIBBIA BALENA INOX fissaggio a 3 barre • WHALE S.STEEL BUCKLE 3 bar loop • BOUCLE BALEINE INOX 3 barres 		10,50
FI105	50 mm, 1 pc			<ul style="list-style-type: none"> • FIBBIA SQUALO INOX fissaggio a 3 barre • SHARK S.STEEL BUCKLE 3 bar loop • BOUCLE REQUIN INOX 3 barres
FI102	50 mm, 1 pc	<ul style="list-style-type: none"> • FIBBIA STANDARD INOX fissaggio a 3 barre • STANDARD S.STEEL BUCKLE 3 bar loop • BOUCLE STANDARD INOX 3 barres 		10,50
FI102/25	50 mm, 25 pcs			-



AI0650N



AI0650B









AI0650G



AI0650V





code	taille/size	descrizione/description/description	colour	euro
AI0650N	4 pcs	<ul style="list-style-type: none"> • FERMAPIOMBI standard NYLON 3 barre • WEIGHT KEEPER standard NYLON 3 bars • STOP PLOMB standard NYLON 3 barres 		10,50
AI0650B				
AI0650G				
AI0650V				
AI0640/N	50 pcs	<ul style="list-style-type: none"> • FERMAPIOMBI standard NYLON 3 barre • WEIGHT KEEPER standard NYLON 3 bars • STOP PLOMB standard NYLON 3 barres 		-
AI0640/G	50 pcs			-



AA0200

code	taille/size	descrizione/description/description	colour	euro
AA0200	3 kg	<ul style="list-style-type: none"> • SCHIENALINO HUNT lastra piombo, fasce in gomma regolabili, clip fissaggio sternale • HUNT LEAD BACK PLATE, adjustable rubber band, sternal fixing clip • BAUDRIER feuille de plomb, sangle caoutchouc réglable 		85,50

AA0210BK
AA0211BK
AA0212BKAA0210M
AA0211M
AA0212M

code	taille/size	descrizione/description/description	colour	euro
AA0210BK	M neoprene 3,5 mm	<ul style="list-style-type: none"> • SCHIENALINO SPIDER 6 tasche porta piombi, clip fissaggio sternale, clip fissaggio cintura (fornito senza zavorra) • SPIDER VEST 6 weight pockets, sternal fixing clip, fastening belt (supplied without weight) • BAUDRIER NEOPRENE SPIDER 6 poches de poids, clip de fixation sternal, clip de fixation à la ceinture (fourni sans lest) 		41,50
AA0211BK	L neoprene 3,5 mm			
AA0212BK	XL neoprene 3,5 mm			
AA0210M	M neoprene 3,5 mm	<ul style="list-style-type: none"> • SCHIENALINO SPIDER CAMO, 6 tasche porta piombi, clip fissaggio sternale, clip fissaggio cintura (fornito senza zavorra) • SPIDER VEST 6 weight pockets, sternal fixing clip, fastening belt (supplied without weight) • BAUDRIER NEOPRENE SPIDER CAMO, 6 poches de poids, clip de fixation sternal, clip de fixation à la ceinture (fourni sans lest) 		
AA0211M	L neoprene 3,5 mm			
AA0212M	XL neoprene 3,5 mm			



code	taille/size	descrizione/description/description	colour	euro
ZI0100	3 • tasche • pockets • pochés	<ul style="list-style-type: none"> • CINTURA CON TASCHE fibbia NYLON, poliestere 600, chiusura velcro • POCKET BELT NYLON buckle, polyester 600, with velcro fastening • CEINTURE AVEC POCHEs boucle NYLON, polyester 600, fermeture Velcro 	■	44,50
ZI0110	4 • tasche • pockets • pochés			47,50
ZI0120	5 • tasche • pockets • pochés			51,00
ZI0121	3 • tasche • pockets • pochés			46,50
ZI0122	4 • tasche • pockets • pochés			49,50
ZI0123	5 • tasche • pockets • pochés			53,00



ZI0131

code	taille/size	descrizione/description/description	colour	euro
ZI0131	4 • tasche • pockets • pochés	<ul style="list-style-type: none"> • CINTURA CON TASCHE "ELITE" fibbia INOX, poliestere 600 • POCKET BELT "ELITE" S. STEEL buckle, polyester 600 • CEINTURE AVEC POCHEs "ELITE" boucle NYLON, polyester 600, fermeture Velcro 	■	56,00



ZI0132

code	taille/size	descrizione/description/description	colour	euro
ZI0132	-	<ul style="list-style-type: none"> • TASCA SINGOLA "ELITE" poliestere 600 • SINGLE POCKET "ELITE" polyester 600 • POCHE OPTIONELLE POUR CEINTURE "ELITE" polyester 600 	■	16,00



KF0204



KF0207



code	taille/size	descrizione/description/description	colour	euro
KF0204	<ul style="list-style-type: none"> • lama INOX • S.STEEL blade • lame en acier inoxydable 10 cm 	<ul style="list-style-type: none"> • COLTELLO INOX "T-REX" fodero rigido, clip per fissaggio cintura, cinghiolo elastico • S.STEEL KNIFE "T-REX" hard sheath, belt fixing clip, elastic lanyard • COUTEAU "T-REX" fourreau rigide, clip ceinture, sangle élastique 	■	105,50
KF0207	<ul style="list-style-type: none"> • lama INOX • S.STEEL blade • lame en acier inoxydable 9 cm 	<ul style="list-style-type: none"> • SK21 DIVERS KNIFE coltello/forbice, fodero rigido, clip fissaggio cintura, clip fissaggio frusta, laccioli velcro • SK21 DIVERS KNIFE knife/scissor, hard sheath, belt fixing clip, hose fixing clip, velcro lanyard • COUTEAU SK21 couteau/ciseaux, fourreau rigide, clip de fixation à la ceinture, clip de fixation au tuyau, bandes velcro 	■	100,50



KF0302

KF0305



KF0308

KF0309

code	taille/size	descrizione/description/description	colour	euro
KF0305	lama INOX/S.STEEL blade 8 cm	<ul style="list-style-type: none"> • COLTELLO SERRAMANICO con moschettone di sicurezza • FOLDABLE KNIFE with safety carabiner • COUTEAU PLIANT INOX avec mousqueton de sécurité 	■	48,00
KF0302	lama INOX/S.STEEL blade 8 cm	<ul style="list-style-type: none"> • COLTELLO SERRAMANICO • FOLDABLE KNIFE • COUTEAU PLIANT 	■	25,00
KF0309	lama INOX/S.STEEL blade 9 cm	<ul style="list-style-type: none"> • COLTELLO "SHOGUN" con fodero in tessuto da fissare al braccio • KNIFE "SHOGUN" with fabric sheath to attach to the arm • COUTEAU "SHOGUN" avec fourreau en tissu à fixer au bras 	■	41,00
KF0308	lama INOX/S.STEEL blade 5 cm	<ul style="list-style-type: none"> • COLTELLO DIR fodero tessuto • DIR KNIFE fabric sheath • COUTEAU DIR fourreau souple en tissu 	■	20,50



	code	taille/size	descrizione/description/description	colour	euro
St. Mrs	KF0310	TITANIO 9,9X4 cm	<ul style="list-style-type: none"> • TAGLIA SAGOLA MULTI CUT lama fissa taglia sagole fino a ø 10 mm, lama seghettata taglia sagole fino a ø 30 mm, fodero tessuto • MULTI CUT line cutter: fixed blade - lines up to ø 10 mm knife: serrated blade - lines up to ø 30 mm, fabric sheath • MULTI CUT lame fixe de coupe-ligne jusqu'à ø 10 mm, lame dentelée de coupe-ligne jusqu'à ø 30 mm, fourreau en tissu 	Yellow	52,50
St. Mrs	KF0303	13,4x4,4 cm	<ul style="list-style-type: none"> • TAGLIA SAGOLA doppia lama INOX, fodero RIGIDO • LINE CUTTER S.STEEL double blade, PLASTIC sheath • COUPE-FIL à double lame en acier inoxydable, fourreau rigide 	Black	25,50
St. Mrs	KF0303G			Yellow	
St. Mrs	KF0303R			Red	
	AI0670	19,5x10 cm	<ul style="list-style-type: none"> • FORBICE TAGLIATUTTO con fodero, acciaio INOX • SCISSORS with sheath, S.STEEL • CISEAUX avec fourreau, acier inoxydable 	Black	31,50
	AI0670/1			<ul style="list-style-type: none"> • FORBICE TAGLIATUTTO solo forbice, acciaio INOX • SCISSORS without sheath, S.STEEL • CISEAUX ciseaux uniquement, acier inoxydable 	Black



	code	taille/size	descrizione/description/description	colour	euro
	RB0894	Ø 0,5x14 cm 3 pcs	<ul style="list-style-type: none"> • UTENSILE IN OTTONE toglì O-RING • BRASS TOOL O-RING remover • OUTIL EN LAITON retirer le joints 	Blue	46,50



AI0680

AI0683

	code	taille/size	descrizione/description/description	colour	euro
	AI0680	12x2,5x4 cm	<ul style="list-style-type: none"> • UTENSILE MULTIUSO acciaio INOX, chiavi fisse, brugole, giraviti, toglì O-R • MULTI PURPOSE TOOL S.STEEL, wrenches, allen wrenches, screwdrivers, O-R remover • MULTI TOOL acier inoxydable, clés de serrage, clés allen, tournevis, démontage O-R 	Grey	37,50
	AI0683	6x3x2 cm	<ul style="list-style-type: none"> • MINI UTENSILE acciaio INOX, brugole, giraviti, toglì O-R • MINI TOOL S.STEEL, O-R remover, allen wrenches, screwdrivers • MINI TOOL INOX, clés allen, tournevis, démonteur O-R 	Grey	37,00



AI0682



AI0681



AI0695



code	taille/size	descrizione/description/description	colour	euro
St. Mrs AI0682	13X5 cm	<ul style="list-style-type: none"> • MICROTOOL TWIN-K acciaio INOX chiavi fisse 10-12-13-14-15-16-17 mm • MICROTOOL TWIN-K S.STEEL multi wrench 10-12-13-14-15-16-17 mm • MICRO-OUTIL TWIN-K clés en acier inoxydable 10-12-13-14-15-16-17 mm 		23,00
St. Mrs AI0681	8,5x8,5 cm	<ul style="list-style-type: none"> • MICROTOOL RADIUS acciaio INOX chiavi fisse 13-14-15-17 mm brugole 4-5-6-8 m • MICROTOOL RADIUS S.STEEL multi wrench 13-14-15-17 mm allen wrench 4-5-6-8 mm • MICRO-OUTIL RADIUS clés en acier inoxydable 13-14-15-17 mm clés Allen 4-5-6-8 mm 		36,00
St. Mrs AI0695	-	<ul style="list-style-type: none"> • KIT MANUTENZIONE n.1 radius, n.1 twin-k, grasso silicone, kit O-Ring • REPAIR KIT n.1 radius, n.1 twin-k, silicone grease, kit O-Ring • KIT DE MAINTENANCE n. 1 radius, n.1 twin-k, kit joints, graisse silicone 		78,00



AI0684



AI0685



code	taille/size	descrizione/description/description	colour	euro
AI0684	-	<ul style="list-style-type: none"> • CACCIAVITE PER RUBINETTERIE • SCREWDRIVER FOR BOTTLE VALVES • TOURNEVIS POUR LES VALVES DES BOUTEILLE 		25,00
AI0685	-	<ul style="list-style-type: none"> • CACCIAVITE PER VALVOLA JACKET • SCREWDRIVER FOR BCD VALVE • TOURNEVIS POUR LA VALVE DE STAB 		



JTS076KIT



BH0670

code	taille/size	descrizione/description/description	colour	euro
JTS076KIT	-	<ul style="list-style-type: none"> • KIT X01-V01 per manutenzione power inflator • KIT X01-V01 for power inflator maintenance • KIT ENTRETIEN POUR DS X01-V01 pour la maintenance des stab inflator 		189,00
BH0670	-	<ul style="list-style-type: none"> • PINZA SLEEVE utensile in acciaio temperato per bloccaggio sleeve • SLEEVE TOOL iron tool to close sleeves • PINCE POUR SLEEVES outil en acier trempé pour le verrouillage des sleeve 		48,50



AM0300



AM0400



AM0200

code	taille/size	descrizione/description/description	colour	euro
AM0300	-	<ul style="list-style-type: none"> • APPENDINO per mute/jacket, fissaggio fruste • HANGER multi hanger for suits/bc/regulators • CINTRE MULTI USAGE vetement/stab/détendeur 		20,00
AM0400	-	<ul style="list-style-type: none"> • APPENDINO per stagne, "upside down" • HANGER "upside down" hanger for dry suits • CINTRE RÉVERSIBLE pour combinaison étanche 		26,50
AM0200	-	<ul style="list-style-type: none"> • APPENDINO per mute umide/stagne • HANGER hanger for wet/dry suits • CINTRE COMBINAISON vetement/combinaison étanche 		27,50

St. Mrs



code	taille/size	descrizione/description/description	colour	euro
D01.25	+1.25	<ul style="list-style-type: none"> • LENTI DIVE STICKTITE 3 cm • DIVE STICKTITE LENSES 3 cm • STICKTITE LENTILLES 3 cm 		37,50
D01.50	+1.50			
D01.75	+1.75			
D02.00	+2.00			
D02.50	+2.50			
D03.00	+3.00			



AD0800
AD0801



AD0802
AD0803



code	taille/size	descrizione/description/description	colour	euro
AD0800	S/M 3 mm	<ul style="list-style-type: none"> • BANDANA NEOPRENE con clip di regolazione • BANDANA NEOPRENE with adjustment strap • BANDANA NEOPRENE avec sangle de réglage 		29,50
AD0801	L/XL 3 mm			
AD0802	S/M 3 mm			
AD0803	L/XL 3 mm			



ES: IN/SQL

- doppio foglio
- double layer
- feuille double



ES: IN/LAZY-DV

- doppio velcro
- double velcro
- velcro double



ES: IN/SDFL-V

- con velcro
- with velcro
- avec velcro

DIVE FLAG



IN/FLAG



IN/FLAG-DV



IN/FLAG-V



IN/SDFL

St. Mrs



IN/SDFL-DV



IN/SDFL-V



IN/RDS



IN/RDS-DV



IN/RDS-V



IN/MAL



IN/MAL-DV



IN/MAL-V

DOLPHIN



IN/3DOL



IN/3DOL-DV



IN/3DOL-V



IN/1DOL

St. Mrs



IN/1DOL-DV



IN/1DOL-V



IN/6DOL



IN/6DOL-DV



IN/6DOL-V

FISH



IN/LAZY



St. Mrs

IN/LAZY-DV



IN/LAZY-V



IN/CLW



IN/CLW-DV



IN/CLW-V



IN/MNT



St. Mrs

IN/MNT-DV



IN/MNT-V



IN/WHL



St. Mrs

IN/WHL-DV



IN/WHL-V

DIVE COMICS



IN/POP



IN/POP-DV



IN/POP-V



IN/SUB



St. Mrs

IN/SUB-DV



IN/SUB-V



IN/DHH



IN/DHH-DV



IN/DHH-V



IN/PIRA



St. Mrs

IN/PIRA-DV



IN/PIRA-V

TEXTURE



IN/GOLD



IN/GOLD-DV



IN/GOLD-V



IN/BUSSO



IN/BUSSO-DV



IN/BUSSO-V



IN/TEN



St. Mrs

IN/TEN-DV



IN/TEN-V



IN/HART



IN/HART-DV



IN/HART-V

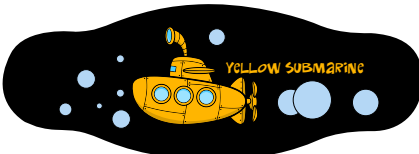

IN/SBM



IN/SBM-DV



IN/SBM-V



IN/TURTLE



IN/TURTLE-DV



IN/TURTLE-V



IN/DRAGO



IN/DRAGO-DV



IN/DRAGO-V



IN/GREEN



IN/GREEN-DV



IN/GREEN-V



IN/IMBD



IN/IMBD-DV



IN/IMBD-V

TEXTURE



IN/REEF



IN/REEF-DV

St. Mrs



IN/REEF-V



IN/ACID



IN/ACID-DV



IN/ACID-V

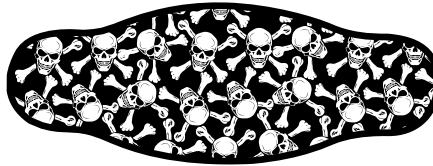

IN/TEX



IN/TEX-DV

St. Mrs



IN/TEX-V



IN/10DOL



IN/10DOL-DV



IN/10DOL-V



IN/FOCA



IN/FOCA-DV



IN/FOCA-V



IN/MRR



IN/MRR-DV

St. Mrs



IN/MRR-V



IN/FRZ



IN/FRZ-DV

St. Mrs



IN/FRZ-V



IN/BRN



IN/BRN-DV

St. Mrs



IN/BRN-V



IN/CORL



IN/CORL-DV

St. Mrs



IN/CORL-V

TEXTURE



IN/FISH



St. Mrs

IN/FISH-DV



IN/FISH-V



IN/FISH2



IN/FISH2-DV



IN/FISH2-V



IN/KOYPINK



IN/KOYPINK-DV



IN/KOYPINK-V



IN/HAWAII



IN/HAWAII-DV



IN/HAWAII-V

WATER

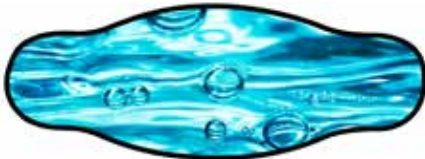

IN/WATR



St. Mrs

IN/WATR-DV



IN/WATR-V



IN/BUBL



St. Mrs

IN/BUBL-DV



IN/BUBL-V

BARRACUDA



IN/CUDA



St. Mrs

IN/CUDA-DV



IN/CUDA-V



IN/BRC



IN/BRC-DV



IN/BRC-V

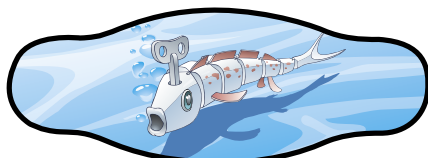

IN/TOY



IN/TOY-DV



IN/TOY-V

SHARK



IN/SHRK



St. Mrs IN/SHRK-DV



IN/SHRK-V



IN/FRI



St. Mrs IN/FRI-DV



IN/FRI-V



IN/SQL



St. Mrs IN/SQL-DV



IN/SQL-V



IN/DAN



IN/DAN-DV



IN/DAN-V



IN/HARLEY



IN/HARLEY-DV



IN/HARLEY-V









IN/CYAN



IN/CYAN-DV



IN/CYAN-V

code	taille/size	descrizione/description/description	colour	euro
 ES: IN/SQL	22x9 cm	<ul style="list-style-type: none"> • MASK STRAP cinturino neoprene doppio foglio • MASK STRAP double layer • MASK STRAP sangle en néoprène à double feuille 		
 ES: IN/WATR-DV	19x9,5 cm	<ul style="list-style-type: none"> • MASK STRAP cinturino neoprene doppio velcro • MASK STRAP double velcro • MASK STRAP sangle double velcro en néoprène 		14,50
 ES: IN/SDFL-V	26,5x8 cm	<ul style="list-style-type: none"> • MASK STRAP cinturino neoprene con velcro • MASK STRAP velcro • MASK STRAP sangle en néoprène avec velcro 		



code	taille/size	descrizione/description/description	colour	euro
AI0510-M	M	<ul style="list-style-type: none"> • CINTURINO PINNE a molla INOX, con attacco universale • FIN STRAP S.STEEL spring, universal connection • SANGLE PALME A RESSORT à ressort INOX, avec connexion universelle 	■	77,50
AI0510-L	L			83,00
AI0510-XL	XL			86,00
AI0511-M	M	<ul style="list-style-type: none"> • CINTURINO PINNE a molla INOX, con attacco "jetfin" • FIN STRAP S.STEEL spring, "jetfin" connection • SANGLE JETFIN S.STEEL spring, "jetfin" connection 	■	83,00
AI0511-L	L			86,00
AI0511-XL	XL			88,50
AI0550	1 pc 44x3x0,5 cm	<ul style="list-style-type: none"> • CINTURINO PINNE regolabile, in gomma • FIN STRAP adjustable, rubber • FIN STRAP réglable, caoutchouc 	■	9,00
AI0550/CF	12 pcs 44x3x0,5 cm			-
AI0551	S, 2 pcs	<ul style="list-style-type: none"> • FISSA PINNE in gomma • FIN HOLDER rubber • FIXE PALME caoutchouc 	■	16,50
AI0552	M, 2 pcs			
AI0553	L, 2 pcs			



code	taille/size	descrizione/description/description	colour	euro
AI0520/1	20 mm, 1 pc	<ul style="list-style-type: none"> • CINTURINO MASCHERA silicone, NERO • MASK STRAP silicone, BLACK • SANGLE MASQUE silicone, NOIR 	■	8,50
AI0520	20 mm, 25 pcs			-
AI0525/1	20 mm, 1 pc	<ul style="list-style-type: none"> • CINTURINO MASCHERA silicone, TRASPARENTE • MASK STRAP silicone, CLEAR • SANGLE MASQUE silicone, TRANSPARENT 	□	8,50
AI0525	20 mm, 25 pcs			-
JTS615	15 mm, 1 pc	<ul style="list-style-type: none"> • CINTURINO MASCHERA silicone, NERO • MASK STRAP silicone, BLACK • SANGLE MASQUE silicone, NOIR 	■	10,00



code	taille/size	descrizione/description/description	colour	euro
AI0527	Ø 23 mm, 25 pcs	<ul style="list-style-type: none"> • CINTURINO SNORKEL silicone TRASPARENTE per fissaggio snorkel al cinturino della maschera • SNORKEL STRAP CLEAR silicone, fixes snorkel to mask • FIXE TUBA silicone transparent pour attacher le tuba à la sangle du masque 	■	-
AI0527/S	Ø 23 mm, 1 pc			4,50
AI0528	Ø 25 mm, 25 pcs	<ul style="list-style-type: none"> • REGGI SNORKEL RIGIDO • HARD SNORKEL HOLDER • SUPPORT RIGIDE POUR TUBA 	■	-
AI0528/S	Ø 25 mm, 1 pc			4,00
AI0580	coppia/couple	<ul style="list-style-type: none"> • CINTURINI COLTELLO 1 lungo, 1 corto, gomma • KNIFE STRAP 1 long, 1 short, rubber • SANGLES COUPEAU 1 longue + 1 courte, caoutchouc 	■	10,50

AI0591



AI0590G



AI0590N



code	taille/size	descrizione/description/description	colour	euro
St. Mrs AI0591	sagola elastica / elastic line Ø 3 mm	<ul style="list-style-type: none"> • LACCILO SICUREZZA elastico per fissaggio attrezzature come lampade e macchine fotografiche • SAFETY STRAP elastic fixing for equipment such as lamps and cameras • DRAGONE ELASTIQUE élastique pour fixer des équipements tels que des lampes et des caméras 		6,50
St. Mrs AI0590G	sagola /line Ø2 mm	<ul style="list-style-type: none"> • LACCILO UNIVERSALE per fissaggio attrezzature: lampade, macchine fotografiche, con sagola • UNIVERSAL STRAP fixing for equipment such as lamps and cameras, with line • DRAGONE UNIVERSELLE pour fixer des équipements tels que des lampes et des caméras 		9,00
St. Mrs AI0590N				



code	taille/size	descrizione/description/description	colour	euro
AI0600/B	25 mm, 1 pc	<ul style="list-style-type: none"> • WATCH OUT cinturino orologio con anelli INOX • WATCH OUT velcro watch strap with S.STEEL rings • WATCH OUT bracelet montre avec anneaux INOX 		13,50



AI0601



code	taille/size	descrizione/description/description	colour	euro
AI0601	display, 36 pcs	<ul style="list-style-type: none"> • GLASSES STRAP lacciolo occhiali, tubino in gomma galleggiante • GLASSES STRAP glasses strap, rubber floating tube • GLASSES STRAP lacet lunettes tube silicone flottant 		-
AI0601/SE	36 pcs			5,00 cad



BH0933

DESIGN



St. Mrs

code	taille/size	descrizione/description/description	colour	euro
BH0933	80x30x15 cm	<ul style="list-style-type: none"> • BOA PIATTA BICAMERA OASI con camera di protezione esterna in pvc ad alta resistenza, asta 40 cm, bandiera 20x30 cm, tasca porta oggetti, elastici porta tutto, fondo a rete, 5x portafucili, porta aste, sagola 20 m • DOUBLE BLADDER FLAT OASI BUOY with external high resistance PVC protection, 40 cm flagstaff, 20x30 cm flag, multi purpose pocket, elastic holders, net bottom, 5x gun holders, shaft holder, 20 m line • BOUEE DOUBLE ENVELOPPE "OASI" avec chambre de protection extérieure en pvc haute résistance, manche de 40 cm, drapeau de 20x30 cm, poche de rangement, sangles élastiques polyvalentes, fond de filet, porte-arbalètes 5x, porte-canne, ligne de 20 m 		83,00



BH0850

DESIGN



code	taille/size	descrizione/description/description	colour	euro
BH0850	90x62x16 cm 2,5 kg	<ul style="list-style-type: none"> • PLANCETTA OKIPA 2 GONFIABILE camera di protezione esterna ad alta resistenza in PVC, 3 camere d'aria interne separate, asta 40 cm, bandiera 20x30 cm, elastici porta tutto, fondo PVC, 2 porta fucili con anello in silicone, 2 maniglie sulla prua, spallacci, tasca porta oggetti • INFLATABLE BOARD OKIPA 2 3 inner separated bladders with high resistance PVC protection, 40 cm flagstaff, 20x30 cm flag, fastening lanyards, PVC base, 2 gunholders with silicone rings, 2 handles on prow, shoulder straps, multi purpose pocket • PLANCHE OKIPA3 chambre de protection extérieure en PVC haute résistance, 3 chambres à air intérieures séparées, tige de 40 cm, drapeau de 20x30 cm, porte-tout élastique, fond en PVC, 2 porte-arbalètes avec anneau en silicone, 2 poignées sur l'arc, bretelles, poche de rangement 		154,50

DESIGN



DESIGN



code	taille/size	descrizione/description/description	colour	euro
BH086/SPL	-	• SPALLACCI per Okipa/Okipa2/Okipa3/Okipa light • SHOULDER STRAPS for Okipa/Okipa2/Okipa3/Okipa light • BRETELLES per Okipa/Okipa2/Okipa3/Okipa light		12,00
BH0100	4 pcs	• OR PER OKIPA silicone • OKIPA OR silicone • OKIPA OR silicone		16,00



BH0932



BH0934



AI0931



AI0932

DESIGN



St. Mrs

DESIGN



code	taille/size	descrizione/description/description	colour	euro
BH0932	-	<ul style="list-style-type: none"> • BOA MONSTER bicamera con camera di protezione esterna in PVC ARANCIO ad alta resistenza, asta 1,32 m, bandiera 30x25 cm, peso bilanciamento 293 gr, sagola 20 m • MONSTER BUOY double bladder buoy with external high resistance ORANGE PVC protection, flagstaff 1,32 m, flag 30x25 cm, 293 gr balancing weight, 20 m line • BOUÉE DOUBLE ENVELOPPE "MONSTER" chambre double avec chambre de protection extérieure en pvc ORANGE haute résistance, mât 1.32 m, drapeau 30x25 cm, poids de la balance 293 g, ligne 20 m 		82,50
BH0934	-	<ul style="list-style-type: none"> • BOA CLASSIC bicamera con camera di protezione esterna in PVC ARANCIO ad alta resistenza, asta 40 cm, bandiera 20x30 cm • CLASSIC BUOY double bladder buoy with external high resistance ORANGE PVC protection, bladder 40 cm flagstaff, flag 20x30 cm • BOUÉE DOUBLE ENVELOPPE à deux chambres avec chambre de protection extérieure en pvc ORANGE haute résistance, mât de 40 cm, drapeau de 20x30 cm 		43,00
AI0932	-	<ul style="list-style-type: none"> • BOA SILURO bandiera gonfiabile, sagola 20 m • LONG BUOY inflatable flag, 20 m line • BOUÉE LONGUE drapeau gonflable, fil 20 m 	 	30,50
AI0931	-	<ul style="list-style-type: none"> • BOA TONDA bandiera gonfiabile, sagola 20 m • ROUND BUOY inflatable flag, 20 m line • BOUÉE RONDE ø 38 cm, drapeau gonflable, fil 20 m 	 	



AI0925



AI0925/3



AI0924

code	taille/size	descrizione/description/description	colour	euro
AI0925	-	<ul style="list-style-type: none"> • INTERNO BOA PVC, per boa Classic, Monster • INNER BLADDER PVC, for Classic, Monster buoy • VESSIE INTERNE PVC, pour Classic, Monster bouée 	<input type="checkbox"/>	18,00
AI0925/3	2 pcs	<ul style="list-style-type: none"> • INTERNO BOA PVC, per boa Oasi • INNER BLADDER PVC, for Oasi buoy • VESSIE INTERNE PVC, pour Oasi bouée 	<input type="checkbox"/>	30,00
AI0924	3 pcs	<ul style="list-style-type: none"> • INTERNO BOA PVC, per boa Okipa • INNER BLADDER PVC, for Okipa buoy • VESSIE INTERNE PVC, pour Okipa bouée 	<input type="checkbox"/>	43,00



PS0100
PS0110



PS0120
PS0130



code	taille/size	descrizione/description/description	colour	euro
St. Mrs PS0100	30 kg		<input type="checkbox"/>	101,50
St. Mrs PS0110	50 kg	<ul style="list-style-type: none"> • PALLONE DI SOLLEVAMENTO PVC 640 gr/m², anelli INOX, versione 100/200 KG con valvola di scarico • LIFTING BAG PVC 640 gr/m², S.STEEL rings, 100/200 kg with exhaust valve 	<input type="checkbox"/>	117,50
PS0120	100 kg	<ul style="list-style-type: none"> • PARACHUTE DE LEVAGE PVC 640 gr/m², anneaux INOX, version 100/200 KG avec soupape de vidange 	<input type="checkbox"/>	238,00
PS0130	200 kg		<input type="checkbox"/>	258,50



BH094/FL



BH093/FL



AI0955

AI0945



AI0940

AI0950

code	taille/size	descrizione/description/description	colour	euro
BH094/FL	• asta • flagstaff • mat du drapeau 50 cm	• BANDIERA ALFA per Classic, Okipa, Oasi • ALFA FLAG for Okipa, Classic, Oasi buoy • DRAPEAU ALPHA pour Classic, Okipa, Oasi bouée		7,00
BH093/FL	• asta • flagstaff • mat du drapeau 50 cm	• BANDIERA SUB per Classic, Okipa, Oasi • DIVE FLAG for Okipa, Classic, Oasi buoy • DRAPEAU PLONGEE pour Classic, Okipa, Oasi bouée		
St. Mrs AI0955XL	40x55 cm XL	• BANDIERA ALFA BIANCO e BLU tessuto poliestere • ALFA FLAG WHITE and BLUE fabric flag • DRAPEAU ALFA BLANC et BLEU tissu en polyester bouée		17,50
St. Mrs AI0955	40x30 cm • grande • big • grande			17,00
St. Mrs AI0945	30x20 cm • piccola • small • petit			16,00
St. Mrs AI0950XL	40x55 cm XL	• BANDIERA SUB BIANCO e ROSSO tessuto poliestere • DIVE FLAG WHITE and RED fabric flag • DRAPEAU PLONGEE BLANC et ROUGE tissu en polyester bouée		17,50
St. Mrs AI0950	40x30 cm • grande • big • grande			17,00
St. Mrs AI0940	30x20 cm • piccola • small • petit			16,00



AI0940/ITA



AI0940/FRA



AI0940/SPA



AI0940/GER

code	taille/size	descrizione/description/description	colour	euro
AI0940/ITA	30x20 cm	• BANDIERE NAUTICHE tessuto poliestere • NAUTICAL FLAGS polyester • DRAPEAU NAUTIQUE tissu en polyester		16,00
AI0940/FRA				
AI0940/SPA				
AI0940/GER				

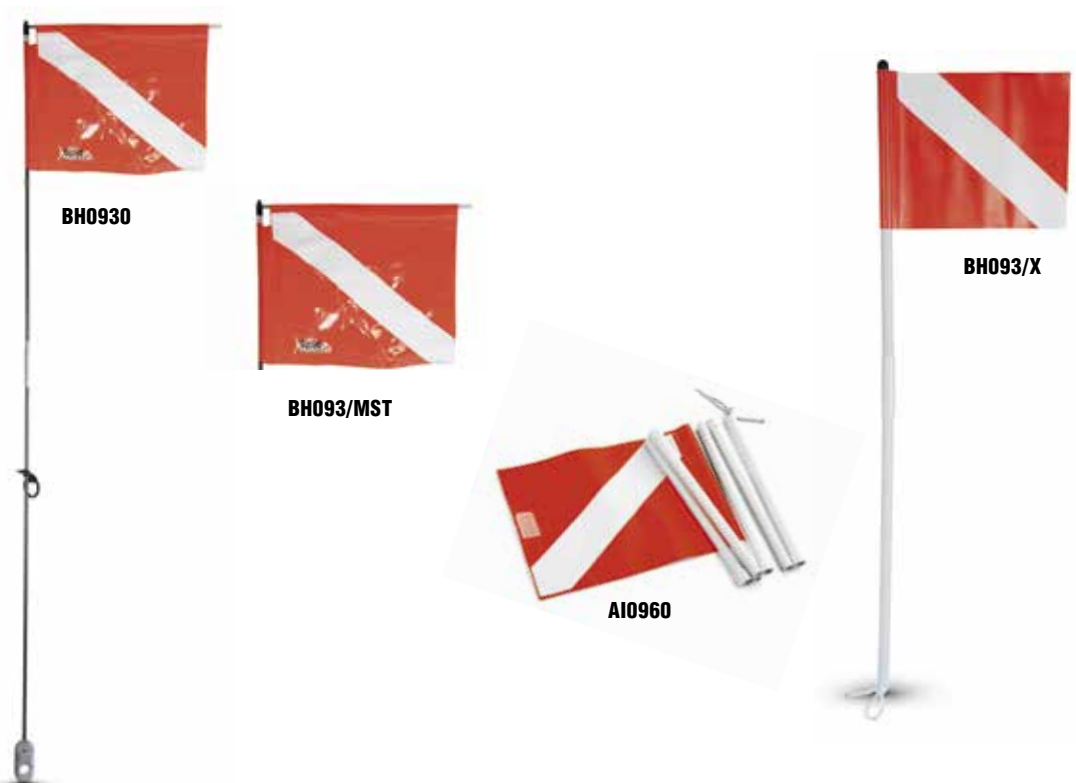

code	taille/size	descrizione/description/description	colour	euro
BH0930	30x25 cm	<ul style="list-style-type: none"> • KIT BANDIERA MONSTER asta 1,32 m peso bilanciamento 293 gr • MONSTER FLAG KIT flagstaff 1,32 m 293 gr balancing weight • KIT DRAPEAU COMPLET "MONSTER" tige 1,32 m poids de la balance 293 g 		60,00
BH093/MST	30x25 cm	<ul style="list-style-type: none"> • BANDIERA MONSTER ricambio solo bandiera • MONSTER FLAG spare part only flag • DRAPEAU MONSTER drapeau de remplacement uniquement 		12,50
AI0960	1,55 m	<ul style="list-style-type: none"> • BANDIERA SMONTABILE montata, segmenti in PVC, elastico interno, bandiera PVC • FOLD UP FLAGSTAFF mounted, PVC flagstaff, inner elastic line, PVC flag • DRAPEAU AVEC MAT PLIABLE monté, segments en PVC, élastique interne, drapeau en PVC 		22,00
BH093/X	-	<ul style="list-style-type: none"> • BANDIERA SMONTABILE 2 segmenti in pvc, elastico interno, asta PVC 80 cm • FOLD UP FLAGSTAFF 2 mounted PVC flagstaff segments, inner elastic line, PVC flagstaff 80 cm • DRAPEAU AVEC MAT PLIABLE 2 segments en pvc, élastique interne, tige en pvc 80 cm 		17,00



BH0092



BH0093



BH0094



SG0025

	code	taille/size	descrizione/description/description	colour	euro
St. Mrs	BH0092	33x12x2 cm	<ul style="list-style-type: none"> • AVVOLGISAGOLA MAXI senza sagola • LINE HOLDER MAXI without line • ENROULEUR DE LIGNE MAXI sans fil 		10,00
St. Mrs	BH0093	23x8x2 cm	<ul style="list-style-type: none"> • AVVOLGISAGOLA MINI senza sagola • LINE HOLDER MINI without line • ENROULEUR DE LIGNE MINI senza sagola 		8,50
St. Mrs	BH0094	23x8x2 cm sagola/line 20 m	<ul style="list-style-type: none"> • AVVOLGISAGOLA MINI • LINE HOLDER MINI • ENROULEUR DE LIGNE MINI 		17,50
	SG0025	Ø 2 mm, 20 m	<ul style="list-style-type: none"> • SAGOLA PER BOA segna sub • LINE FOR BUOYS diver marker line • BOBINE DE FIL pour bouée plongeur 		10,00



code	taille/size	descrizione/description/description	colour	euro
AI0730N	Ø 20x160 mm	<ul style="list-style-type: none"> • MARACHAS 95 avvisatore sonoro a scuotimento manuale, ALLUMINIO verniciato, lacciolo • MARACHAS 95 alarm horn, hand shaking, ALUMINIUM body, lanyard • MARACHAS 95 cornet à secousses à main, ALUMINIUM peint, lanière 	■	34,50
AI0730G			■	
AI0730NMD	Ø 20x160 mm	<ul style="list-style-type: none"> • MARACHAS 95 CON SUPPORTO MAGNETICO avvisatore sonoro a scuotimento manuale, ALLUMINIO verniciato, lacciolo, con magnete per aggancio frusta • MARACHAS 95 WITH MAGNET alarm horn, hand shaking, painted ALUMINIUM body, lanyard, magnetic hose holder • MARACHAS 95 AVEC CLIP MAGNETIQUE corne d'agitation à main, en ALUMINIUM peinte, avec aimant pour fixation du flexible 	■	44,00
AI0730GMD			■	
AI0729	Ø 20 mm	<ul style="list-style-type: none"> • SUPPORTO MAGNETICO aggancio per fruste per marachas • MAGNETIC HOLDER hose holder for marachas • CLIP MAGNETIQUE pour marachas 95 	■	11,50



code	taille/size	descrizione/description/description	colour	euro
AI0330	7,5x10,5 cm	<ul style="list-style-type: none"> • SPECCHIETTO infrangibile, rettangolare, con cordino • MIRROR unbreakable, rectangular, with cord • MIROIR uincassable, rectangulaire, avec lanyard 	■	9,50
AI0710	-	<ul style="list-style-type: none"> • FISCHIETTO segnalatore sonoro emergenza NYLON, ARANCIO • EMERGENCY WHISTLE emergency acoustic warning NYLON, ORANGE • SIFFLET balise d'urgence nylon, orange 	■	5,50
AI0110	-	<ul style="list-style-type: none"> • DIVERS SAFETY KIT kit emergenza: fischiotto, specchietto, mini flash ROSSA, boa leggera 13,5x250 cm • DIVERS SAFETY KIT safety kit: whistle, mirror, RED mini flash, light buoy 13,5x250 cm • KIT DE SÉCURITÉ PLONGEURS kit d'urgence: sifflet, miroir, mini flash rouge, bouée lumineuse 13,5x250 cm 	■	32,00
AI0910	13,5x250 cm	<ul style="list-style-type: none"> • BOA DECO LEGGERA • LIGHT DECO BUOY • PETIT PARACHUTE DE PALIER 	■	5,00



code	taille/size	descrizione/description/description	colour	euro
AI0733	8 cm, 120 decibel	<ul style="list-style-type: none"> • AMPHI HORN avvisatore sonoro, orientabile 180°, innesto jacket standard • AMPHI HORN alarm horn, 180° swiveling, standard BC connection • AMPHI HORN cornet, pivotant à 180°, connexion pour stab 	■	108,50
AI0720	-	<ul style="list-style-type: none"> • SCUBOING segnalatore sonoro da montare sulla bombola • SCUBOING acoustic warning, to be mounted on the tank • SCUBOING beeper à monter sur le cylindre 	■	11,00
APS030	-	<ul style="list-style-type: none"> • POCKET MASK maschera per la rianimazione artificiale • POCKET MASK artificial resuscitation mask • MASQUE DE POCHE masque pour la réanimation artificielle 	■	32,00



St. Mrs

St. Mrs

St. Mrs

code	taille/size	descrizione/description/description	colour	euro
CB0151		• TAPPO DIN CANDY BOX 10 ROSSI, 10 BLU, 10 NERI • DIN CAP CANDY BOX 10 RED, 10 BLUE, 10 BLACK • BOCAL DE BOUCHON DIN A VIS 10 ROUGE+10 NOIR+10 BLEU		-
AE0151B	• filetto • thread • filet DIN 200/300 BAR	• TAPPO DIN PRIMO STADIO in policarbonato, rotante • DIN BAR ROTATING CAP polycarbonate, rotating cap • BOUCHON DIN 1^{ER} ÉTAGE polycarbonate, rotatif		9,00
AE0151R				
AE0151N				



code	taille/size	descrizione/description/description	colour	euro
AE0150	• filetto • thread • filet DIN 200/300 BAR	• TAPPO DIN PRIMO STADIO NYLON con vano porta O-R • FIRST STAGE DIN CAP NYLON compartment with O-R • BOUCHON DIN NYLON avec compartiment joints		9,00
AE0160	• filetto • thread • filet DIN 300	• TAPPO DIN TECH OTTONE cromato, tappo HP pastiglia di tenuta filetto: impedisce la perdita di miscele in caso di apertura accidentale della bombola • DIN TECH CAP chrome plated BRASS, HP cap, sealing pads: prevents loss of gas mix in case of accidental opening of the tank • BOUCHON DIN TECH laiton chromé, joint de filetage du bouchon HP : empêche la fuite des mélanges en cas d'ouverture accidentelle de la bouteille		27,50
AB0430	• filetto • thread • filet DIN 200 BAR	• TAPPO DIN RUBINETTERIE NYLON • DIN TANK VALVE CAP NYLON • BOUCHON DIN POUR ROBINET NYLON		16,50
AE0152	• filetto • thread • filet DIN 200/300 BAR	• TAPPO DIN PRIMO STADIO NYLON • FIRST STAGE DIN CAP NYLON • BOUCHON DIN 1^{ER} ÉTAGE NYLON		9,00



St. Mrs

code	taille/size	descrizione/description/description	colour	euro
AB0420/2	Ø 8 mm 2 pcs	• ADATTATORE DIN/INT OTTONE cromato, per rubinetto bombola • DIN YOKE ADAPTER CHROME-PLATED BRASS for tank valve • ADAPTATEUR DIN/ÉTRIER laiton chromé pour robinet de bouteille		18,50
AE0285	-	• CAPPUCCIO per rubinetto, protezione in PVC • CAP PVC, protection for tank valve • BOUCHON pour robinet, protection en PVC		12,00
AE0110/5	5 pcs	• TAPPO METALLO per uscite 1° stadio LP 3/8" M • METAL CAP 1° stage plug LP 3/8" M • BOUCHON METAL pour les sorties du 1er étage, LP 3/8" M		14,50
AE0120/5	5 pcs	• TAPPO METALLO per uscite 1° stadio, HP 7/16" M • METAL CAP 1° stage plug HP 7/16" M • BOUCHON METAL pour les sorties du 1er étage, HP 7/16" M		
AE0140	1 pc	• SFERA GOMMA chiusura 1° stadio • RUBBER DUST PLUG 1 st stage yoke		6,00
AE0140/20	20 pcs	• BOUCHON PROTECTION CAOUTCHOUC fermeture 1er étage		-



AE0113



AE0114



AE0115



AE0292



code	taille/size	descrizione/description/description	colour	euro
AE0113	LP I° stadio/stage 3/8" M-3/8" F	<ul style="list-style-type: none"> • RACCORDO GIREVOLE OTTONE cromato • REVOLVING CONNECTOR chromed BRASS • CONNECTEUR ROTATIF laiton chromé 		42,50
AE0114	LP II° stadio/stage 110° 9/16" M-9/16" F			
AE0115	LP II° stadio/stage 90° 9/16" M-9/16" F			
AE0292	I° stadio/stage DIN 200 BAR	<ul style="list-style-type: none"> • STAFFA DIN/INT OTTONE cromato, per trasformazione attacchi • DIN YOKE CONVERTER chrome-plated BRASS, to convert adapters to yoke • CONVERTISSEUR DIN VERS ETRIER laiton chromé, pour la conversion des connexions 		57,00



AB0295



AE0280



AJ0116



AE0127
1/2" M 3/8" F



AE0126
3/8" M 1/2" F

code	taille/size	descrizione/description/description	colour	euro
AB0295	300 BAR	<ul style="list-style-type: none"> • ADATTATORE DIN/INT OTTONE cromato, per rubinetto bombola • DIN YOKE ADAPTER chromed BRASS, for tank valve • DIN/INT ADAPTATEUR laiton chromé, pour robinet à cylindre 		58,50
AE0280	360°	<ul style="list-style-type: none"> • SNODO OTTONE cromato • SWIVEL chromed BRASS • SVALVE DE SURPRESSION laiton chromé 		95,00
AJ0116		<ul style="list-style-type: none"> • SUPPORTO per maggiorazione frusta jacket/stagna • HOSE GRIP helps hose release • ACCROCHE TUYAU laiton chromé 		10,00
AE0126	3/8" M 1/2" F	<ul style="list-style-type: none"> • ADATTATORE LP OTTONE cromato • LP ADAPTER chromed BRASS • ADAPTATEUR laiton chromé 		15,50
AE0127	1/2" M 3/8" F			



AE0112



AE0119E



AE0119J





AE0132



code	taille/size	descrizione/description/description	colour	euro
AE0112	-	<ul style="list-style-type: none"> • ADATTATORE SONDA raccordo HP frusta/sonda • RANSLITTER ADAPTER chromed BRASstransilter adapter for HP hose • ADAPTATEUR POUR HP HOSE raccordement du tuyau HP/de la sonde 		12,00
AE0119E	-	<ul style="list-style-type: none"> • INTERRUTTORE ON/OFF per frusta erogatore • ON/OFF SWITCH for regulator hose • ON/OFF SWITCH pour tuyau detendeur 		44,50
AE0119J	-	<ul style="list-style-type: none"> • INTERRUTTORE ON/OFF per frusta jacket • ON/OFF SWITCH for BC hose • ON/OFF SWITCH pour stab 		70,50
AE0132	LP 3/8" 14 BAR	<ul style="list-style-type: none"> • VALVOLA sovrappressione • VALVE overpressure valve • VALVE surpression 		21,50



code	taille/size	descrizione/description/description	colour	euro
AB0309HD/G	10 L	<ul style="list-style-type: none"> • RETE BOMBOLA • TANK PROTECTIVE NET • FILET DE PROTECTION HD 		15,50
AB0310HD/G	12 L			16,00
AB0320HD/G	15 L			17,00
AB0330HD/G	18 L			18,50
AB0309HD/N	10 L	<ul style="list-style-type: none"> • RETE BOMBOLA • TANK PROTECTIVE NET • FILET DE PROTECTION HD 		15,50
St. Mrs AB0310HD/N	12 L			16,00
St. Mrs AB0320HD/N	15 L			17,00
AB0330HD/N	18 L			18,50



AB0440X



AB0440





AB0418

code	taille/size	descrizione/description/description	colour	euro
AB0440X	Ø 40 mm	<ul style="list-style-type: none"> • MANIGLIA MANGIACAREMELLA maniglia trasporto bombola universale con inserto filettato per il posizionamento di due adattatori DIN/INT • NYLON TANK HANDLE universal tank handle, threaded insert for two DIN/INT adapters • POIGNEE BOUTEILLE AVEC INSERT FILLETE poignée universelle de transport du bouteille avec insert fileté pour le positionnement de deux adaptateurs DIN/INT 		32,50
St. Mrs AB0440	Ø 40 mm	<ul style="list-style-type: none"> • MANIGLIA PER BOMBOLA per ogni tipo di bombola in acciaio, NERO, NYLON • NYLON TANK HANDLE for any type of S.STEEL tank, BLACK, NYLON • POIGNEE BOUTEILLE pour tous types de bouteille en acier, NOIR, NYLON 		25,00
AB0418	-	<ul style="list-style-type: none"> • INSERTO MANGIACAREMELLA filettato per maniglia, supporto in policarbonato, alta resistenza, filetti DIN, viti acciaio INOX • THREADED INSERT threaded for handle, high resistant polycarbonate holder DIN threads, S.STEEL screws • INSERT FILLETE POUR POIGNEE fileté pour poignée, support en polycarbonate, haute résistance, filetage DIN, vis en acier inoxydable 		9,50

AB0400



AB0340

code	taille/size	descrizione/description/description	colour	euro
AB0400	Ø 50x 480 mm	<ul style="list-style-type: none"> • PORTA BOMBOLA PER AUTO per il trasporto di due bombole, PVC antiurto • TANK CAR CARRIER for two tanks, anti-shock PVC • PORTE BOUTEILLE DE VOITURE pour le transport de deux bouteilles, PVC anti-chocs 		68,50
AB0340	nastro/band 50 mm	<ul style="list-style-type: none"> • PORTA BOMBOLA per bombole 10/15/18 L • NYLON TANK HOLDER for tanks 10/15/18 L • PORTE BOUTEILLE NYLON pour bouteilles 10/15/18 L 		26,50

AB0417/5



AB0417



AB0417S



code	taille/size	descrizione/description/description	colour	euro
St. Mrs AB0417/5	5/7 L fascia jacket/BC band	<ul style="list-style-type: none"> • SCHIENALINO con cinghie, fibbia NYLON, nastro 50 mm NERO, fibbie regolazione NYLON • TANK BACKPACK with shoulder straps, NYLON buckle, 50 mm BLACK band, NYLON adjustment buckles • BACKPACK BOUTEILLE avec sangles, boucles en NYLON, bande NOIR 50 mm, boucles de réglage NYLON 	■	65,00
St. Mrs AB0417	15 L fascia jacket/BC band	<ul style="list-style-type: none"> • SCHIENALINO con spallacci imbottiti, fibbia NYLON, nastro 50 mm NERO, fibbie regolazione NYLON • TANK BACKPACK with padded shoulder straps, NYLON buckle, 50 mm BLACK band, NYLON adjustment buckles • BACKPACK BOUTEILLE avec sangles rembourrée, boucles en NYLON, bande NOIR 50 mm, boucles de réglage NYLON 	■	69,00
AB0417S	15 L fascia jacket/BC band	<ul style="list-style-type: none"> • SCHIENALINO con spallacci imbottiti, fibbia NYLON, nastro 50 mm NERO, fibbie regolazione NYLON • TANK BACKPACK with padded shoulder straps, NYLON buckle, 50 mm BLACK band, NYLON adjustment buckles • BACKPACK BOUTEILLE avec sangles rembourrée, boucles en NYLON, bande NOIR 50 mm, boucles de réglage NYLON 	■	100,50



AB0415

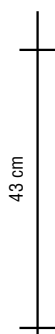

AB0410



AB0414



code	taille/size	descrizione/description/description	colour	euro
AB0415	15L fascia jacket/BC band	<ul style="list-style-type: none"> • SCHIENALINO con spallacci imbottiti, fibbia INOX, nastro 50 mm NERO, fibbie regolazione OTTONE • TANK BACKPACK with padded shoulder straps, INOX buckle, 50 mm BLACK band, BRASS adjustment buckles • BACKPACK BOUTEILLE avec sangles rembourrée, boucles en INOX, bande NOIR 50 mm, boucles de réglage LAITON 	■	109,50
AB0410	43x28 cm	<ul style="list-style-type: none"> • SCHIENALINO senza cinghie, NYLON, NERO • TANK BACK PLATE without shoulder straps, NYLON, BLACK • BACKPACK BOUTEILLE sans bretelles, NYLON, NOIR 	■	19,50
AB0414	5/7L fascia jacket/BC band	<ul style="list-style-type: none"> • SCHIENALINO con tasche con cinghie, fibbia INOX, nastro 50 mm NERO, spallacci imbottiti • TANK BACKPACK with pockets with shoulder straps, S.STEEL buckle, 50 mm BLACK band, padded shoulders • BACKPACK BOUTEILLE avec sangles boucle en acier inoxydable, sangle NOIRE de 50 mm, bretelles rembourrées 	■	121,50



AB0411



AJ0182



AJ0183

code	taille/size	descrizione/description/description	colour	euro
AB0411	31X 7 cm	<ul style="list-style-type: none"> • SPALLACCIO imbottito, per nastro 50 mm • SHOULDER padded, for 50 mm band • RENFORTS EPAULE POUR BACK PACK rembourré, pour bande de 50 mm 	■	34,50
AJ0182	S40	<ul style="list-style-type: none"> • FASCIA ELASTICA fascia elastica per bombola • ELASTIC BAND tank elastic band • SANGLE BOUTEILLE élastique pour bouteille 	■	19,50
AJ0183	S80		■	



AB0450



TK0115



AB0455
AB0456



code	taille/size	descrizione/description/description	colour	euro
AB0450	-	<ul style="list-style-type: none"> • IMBRAGO BOMBOLA DI FASE maniglia gomma, moschettone INOX DIR 98 mm, fascia NYLON con fibbia jacket • STAGE TANK HARNESS rubber handle, S.STEEL DIR carabiner, 98 mm, NYLON band with BC buckle • HARNAIS POUR BOUTEILLE SUP poignée en caoutchouc, mousqueton en acier inoxydable de 98 mm DIR, bande en NYLON avec boucle de stab 	■	53,00
TK0115	-	<ul style="list-style-type: none"> • SUPPORTO PONY TANK piastra acciaio INOX, fascette fissaggio INOX, fascia jacket • PONY TANK HOLDER S.STEEL plate, S.STEEL fixing clamps, BC band • SUPPORT POUR BOUTEILLE PONY plaque en acier inoxydable, colliers de serrage en acier inoxydable, bande d'enveloppe 	■	91,00
AB0455	band 40-160 mm	<ul style="list-style-type: none"> • IMBRAGO BOMBOLA DI FASE fascia INOX, maniglia gomma, moschettone INOX DIR 98 mm • STAGE TANK HARNESS S.STEEL band, rubber handle, S.STEEL DIR carabiner 98 mm • HARNAIS POUR BOUTEILLE TECH bande INOX, poignée caoutchouc, mousqueton INOX DIR 98 mm 	■	63,00
AB0456	band 160-180 mm		■	63,50

St. Mrs



code	taille/size	descrizione/description/description	colour	euro
TK0100	2,30 kg 39x27x3,5 cm	• BACK PLATE spessore 3 mm, INOX • BACK PLATE thickness 3 mm, S.STEEL • CONTREPLAQUE épaisseur 3 mm, INOX		183,00
TK0110	0,86 kg 39x8,5x2 cm	• ADATTATORE per mono bombola, INOX • SINGLE TANK ADAPTER for single tank, S.STEEL • ADAPTATEUR INOX POUR BOUTEILLE pour bouteille, INOX	■	76,50
TK0116	-	• SLITTA PONY TANK INOX • PONY TANK SLIDE S.STEEL • RAIL INOX POUR PONY INOX		156,00



code	taille/size	descrizione/description/description	colour	euro
AB0416	-	• CINGHIAGGIO BIBO con cinghie, fibbia INOX, nastro 50 mm, spallacci imbottiti • DOUBLE TANK SHOULDER STRAPS with shoulder straps, 50 mm band, S.STEEL buckle, padded shoulders • BOUCLES INOX POUR BI BOUTEILLE avec sangles, boucle en acier inoxydable, bande de 50 mm, bretelles rembourrées	■	100,50
AB0445	• coppia • couple	• COLLARI per imbrago bibombola • COLLARS for double tank • COLLIER pour harnais bi-bouteille		8,50



code	taille/size	descrizione/description/description	colour	euro
AB0132	7+7 L	• FONDELLO PER BIBO termogomma • DOUBLE TANK BOOT thermorubber		31,00
AB0135	10+10 L	• CULOT BI-BOUTEILLE caoutchouc thermique		37,00
AB0119	Ø 140 mm 5 L	• FONDELLO PER MONO termogomma • TANK BOOT thermorubber • CULOT BOUTEILLE caoutchouc thermique	■	14,50
AB0120	Ø 170 mm 10 L			18,00
AB0130	Ø 200 mm 15 L			19,00
AB0115	Ø 184 mm	• FONDELLO PER MONO termogomma, per bombola ALLUMINIO • TANK BOOT thermorubber, for ALUMINIUM tank • CULOT BOUTEILLE caoutchouc thermique, pour bouteille ALUMINIUM		29,00



code	taille/size	descrizione/description/description	colour	euro
JTS087	-	<ul style="list-style-type: none"> • COMANDO COMPLETO tubo corrugato, “collo d’anatra” superiore, comando meccanico • COMPLETE POWER INFLATOR corrugated pipe, mechanical operated inflator, upper exhaust valve • INFLATEUR COMPLET tube ondulé, “col canard” supérieur, contrôle mécanique 	■	129,00
JTS088	-	<ul style="list-style-type: none"> • COMANDO COMPLETO tubo corrugato con valvola superiore di scarico, comando standard, pneumatico • COMPLETE POWER INFLATOR corrugated pipe with upper exhaust valve, standard pneumatic control valve • INFLATEUR COMPLET tuyau ondulé avec vanne de sortie supérieure, contrôle standard, pneumatique 	■	123,50
AJ0110	-	<ul style="list-style-type: none"> • VALVOLA SCARICO per jacket • EXHAUST VALVE BCD quick exhaust valve • SOUPAPE DÉCHARGE pour stab 	■	13,50



code	taille/size	descrizione/description/description	colour	euro
JTS077	60 cm	<ul style="list-style-type: none"> • TUBO CORRUGATO Ø 22 interno • CORRUGATED PIPE Ø 22 internal • TUYAU ANNELE Ø 22 interne 	■	42,50
JTS077/1	50 cm			40,00
JTS078	40 cm			27,00



code	taille/size	descrizione/description/description	colour	euro
JTS076	-	<ul style="list-style-type: none"> • POWER INFLATOR X01 meccanico • POWER INFLATOR X01 mechanical control • DIRECT SYSTEM X01 mécanique 	■	84,00
AJ0150	-	<ul style="list-style-type: none"> • POWER INFLATOR V01 standard pneumatico • POWER INFLATOR V01 standard pneumatic • DIRECT SYSTEM V01 pneumatique standard 	■	53,50
AJ0120	-	<ul style="list-style-type: none"> • VALVOLA SCARICO comando superiore • EXHAUST VALVE upper exhaust valve • SOUPAPE HAUTE STAB commande supérieure 	■	40,00
AJ0030/5	5 pcs	<ul style="list-style-type: none"> • GUARNIZIONE SILICONE, per valvola • SEAL SILICONE, for exhaust valve • RONDELLE SILICONE POUR DS silicone, pour valve 	■	56,00
AJ0020/5	5 pcs	<ul style="list-style-type: none"> • INNESTO RAPIDO per frusta jacket • QUICK JOINT for BC hose • RACCORD RAPIDE pour tuyau stab 	■	28,50



code	taille/size	descrizione/description/description	colour	euro
AJ0176	65X68 mm	<ul style="list-style-type: none"> • FIBBIA MINI REBREATHER • MINI S.STEEL REB. BUCKLE • MINI BOUCLE INOX POUR REBREATHER 	■	24,00
AJ0175	85x68 mm	<ul style="list-style-type: none"> • FIBBIA JACKET inox • S.STEEL BC BUCKLE • BOUCLE STAB inoxydable 	■	24,00
JTS041	nastro/band 25 mm	<ul style="list-style-type: none"> • KIT INGUINALE clip maschio + femmina • CROTCH STRAP male + female clip • SANGLE SOUS CUTALE clips mâle + femelle 	■	11,00



AJ0170



AJ0171



AJ0172



AJ0173

code	taille/size	descrizione/description/description	colour	euro
AJ0170	95x66 mm	<ul style="list-style-type: none"> • FIBBIA NYLON JACKET • BC NYLON BUCKLE • BOUCLE NYLON POUR STAB 		10,00
AJ0171				
AJ0172				
AJ0173				

AJ0180/ZL
AJ0180
AJ0180/ZC



AJ0185/ZL
AJ0185



AJ0186



JTS067



code	taille/size	descrizione/description/description	colour	euro
AJ0180/ZL	double tank	<ul style="list-style-type: none"> • FASCIA JACKET FIBBIA NYLON per fissaggio jacket a mono e bibombola • BC BAND NYLON BUCKLE for mono and double tank fastening to BC • SANGLE NYLON pour bi-bouteille 		24,50
AJ0180	mono 12/15/18 l			23,50
AJ0180/ZC	mono 5/7/10 l			23,00
AJ0185/ZL	double tank	<ul style="list-style-type: none"> • FASCIA JACKET FIBBIA INOX per fissaggio jacket a mono e bibombola • BC BAND S.STEEL BUCKLE for mono and double tank fastening to BC • SANGLE NYLON pour fixer les stab sur les bouteilles simples et doubles 		39,00
AJ0185	mono 12/15/18 L			38,50
AJ0186	50X650 mm	<ul style="list-style-type: none"> • FASCIA NYLON PER REBREATHER mini fibbia inox • NYLON BAND FOR REBREATHER mini s.steel buckle • SANGLE NYLON POUR REBREATHER mini boucle inox 		28,50
JTS067	• coppia • couple	<ul style="list-style-type: none"> • FASCE ARGON per fissaggio bombola argon • ARGON BANDS to fix argon tank • ARGON BANDS pour fixer la bouteille d'argon 		29,50

ST0130



ST0150



ST0140



ST0160



code	taille/size	descrizione/description/description	colour	euro
ST0130ST	standard large	<ul style="list-style-type: none"> • COLLO LATTICE • LATEX NECK SEAL • MANCHON LATEX COU 		50,00
ST0130S	small			
ST0130M	medium			
ST0150	taglia unicaone size	<ul style="list-style-type: none"> • POLSO LATTICE CONICO • CONICAL LATEX CUFF • MANCHON CONIQUE POIGNET LATEX 		19,00
ST0140S	small	<ul style="list-style-type: none"> • POLSO LATTICE BOTTIGLIA • BOTTLE NECK LATEX CUFF • MANCHON LATEX FORME GOULOT 		13,00
ST0140M	medium			
ST0140L	large			
ST0160ST	standard	<ul style="list-style-type: none"> • CAVIGLIA LATTICE • LATEX ANKLE • MANCHON LATEX CHEVILLE 		16,00
ST0160S	small			

ST0170M
ST0170ST



ST0191



ST0190L



ST0180H
ST0180L

code	taille/size	descrizione/description/description	colour	euro
ST0170M	medium	• CAPPuccio LATTICE • LATEX HOOD • CAGOULE LATEX	■	85,50
ST0170ST	large			
ST0191	-	• SEDE VALVOLA carico/scarico, gomma • VALVE PORT inlet/outlet valve, rubber • PORT SOUPAPE chargement/déchargement, caoutchouc		17,00
ST0190L	standard	• VALVOLA DI SCARICO • EXHAUST VALVE • VALVE DÉCHARGEMENT		112,50
ST0180H	• high • button • haut	• VALVOLA DI CARICO • INFLATION VALVE • VALVE CHARGEMENT		137,00
ST0180L	• low • button • bas			117,00



SN2200MH



SN-CRI220



SN-C2200

code	taille/size	descrizione/description/description	colour	euro
SN2200MH	3 L	• VASCA LAVAGGIO ultrasuoni, INOX • ULTRASONIC CLEANING TANK S.STEEL, ultrasonic cleaner • CAISSON ULTRA SON INOX	■	1087,00
SN-CRI220	-	• CESTELLO in rete, INOX • TANK CLEANING BASKET net, S.STEEL • PANIER INOX		98,00
SN-C2200	-	• COPERCHIO INOX • CLEANING TANK LID S.STEEL • COUVERCLE INOX		60,00



SN-UG



SN-AC



SN-AF

code	taille/size	descrizione/description/description	colour	euro
SN-UG	1 kg	• SGRASSANTE concentrato • DEGREASER concentrated degreaser • LIQUIDE DEGRAISSANT concentr	-	34,50
SN-AC		• ANTIOSSIDO concentrato, piccole quantità • DEOXIDIZER concentrated deoxidizer, "small amounts" • LIQUIDE ANTI-ROULLE desoxidant, petites quantités		
SN-AF		• ANTIOSSIDO concentrato, grandi quantità • DEOXIDIZER concentrated deoxidizer, "big amounts" • LIQUIDE ANTI-ROULLE desoxidant, grandes quantités		



APN1000



APN1000N



code	taille/size	descrizione/description/description	colour	euro
St. Mrs APN1000	• peso massimo • max. weight • poids maximum	• COLLARE APNEA collare in Cordura® 4 scomparti: 2 fissi da 500 gr + 2 implementabili, regolabile taglia collo 38-44 • NECK WEIGHT Cordura® neck weight 4 compartments 2 fixed of 500 gr + 2 adaptable, adjustable collar size 38 to 44 • PLOMB DE COU RÉGLABLE poids de cou en Cordura® 4 compartiments 2 fixes de 500 gr + 2 adaptables, collier réglable taille 38 à 44		98,50
St. Mrs APN1000N	3 kg			



code	taille/size	descrizione/description/description	colour	euro
APN662/B	250 gr	• ZAVORRA PALLINI NICHELATI • NICKEL PLATED LEAD SHOTS • GRENAILLE PLOMB NICKELE		9,00
APN662/D	500 gr			14,00
APN0662	1 kg			24,00



APN100F

APN100BK

APN100S



SG0080
SG0085

APN350



code	taille/size	descrizione/description/description	colour	euro
St. Mrs APN100S	-	• STRINGINASO ALLUMINIO, regolabile • NOSE CLIP ALUMINIUM, adjustable • PINCE-NEZ ALUMINIUM, adjustable		41,00
St. Mrs APN100BK	-			
APN100F	-			
SG0080	Ø10-22 mm, 10 mm 50 m	• CAVO GUIDA polipropilene • APNEA ROPE polypropilene • LONGE APNEE polypropylène		115,50
SG0085	Ø10-22 mm, 12 mm 100 m			154,00
St. Mrs APN350	100 cm	• CAVO DI SICUREZZA APNEA con moschettone di rilascio • APNEA LAYNARD SECURITY with snap release • SANGLE DE SÉCURITÉ POUR L'APNEE avec mousqueton de déclenchement		86,00



A10446/ART1 6 anelli • ring • anneaux
A10443/ART1 3 anelli • ring • anneaux

St. Mrs



A10446/ART2 6 anelli • ring • anneaux
A10443/ART2 3 anelli • ring • anneaux



A10446/ART3 6 anelli • ring • anneaux
A10443/ART3 3 anelli • ring • anneaux



A10446/ART4 6 anelli • ring • anneaux
A10443/ART4 3 anelli • ring • anneaux



A10446/ART5 6 anelli • ring • anneaux
A10443/ART5 3 anelli • ring • anneaux



A10446/ART6 6 anelli • ring • anneaux
A10443/ART6 3 anelli • ring • anneaux



A10446/ART7 6 anelli • ring • anneaux
A10443/ART7 3 anelli • ring • anneaux



A10446/ART8 6 anelli • ring • anneaux
A10443/ART8 3 anelli • ring • anneaux



A10446/ART9 6 anelli • ring • anneaux
A10443/ART9 3 anelli • ring • anneaux



A10446/ART10 6 anelli • ring • anneaux
A10443/ART10 3 anelli • ring • anneaux



A10446/ART11 6 anelli • ring • anneaux
A10443/ART11 3 anelli • ring • anneaux



A10446/ART12 6 anelli • ring • anneaux
A10443/ART12 3 anelli • ring • anneaux



A10446/ART18 6 anelli • ring • anneaux
A10443/ART18 3 anelli • ring • anneaux

NEW



A10446/ART16 6 anelli • ring • anneaux
A10443/ART16 3 anelli • ring • anneaux



A10446/ART17 6 anelli • ring • anneaux
A10443/ART17 3 anelli • ring • anneaux



A10446/ART19 6 anelli • ring • anneaux
A10443/ART19 3 anelli • ring • anneaux

NEW



code	taille/size	descrizione/description/description	colour	euro
A10443/...	26x18x5 cm	<ul style="list-style-type: none"> • DIVE LOG ART 3 ANELLI porta penna, tasca porta documenti, porta brevetti (senza libretto immersioni) • DIVE LOG ART 3 RINGS pen holder, document pocket, diving licence pocket (dive pages not included) • CARNET DE PLONGEE 3 ANNEAUX porte-stylo, pochette à documents, support de brevet (sans livret de plongée) 		41,50
A10446/...		<ul style="list-style-type: none"> • DIVE LOG ART 6 ANELLI porta penna, tasca porta documenti, porta brevetti (senza libretto immersioni) • DIVE LOG ART 6 RINGS pen holder, document pocket, diving licence pocket (dive pages not included) • CARNET DE PLONGEE 6 ANNEAUX porte-stylo, pochette à documents, support de brevet (sans livret de plongée) 		



A10440/ART1
6 anelli • ring • anneaux



A10440/ART2
6 anelli • ring • anneaux



A10440/ART3
6 anelli • ring • anneaux



A10440/ART7
6 anelli • ring • anneaux



A10440/ART4
6 anelli • ring • anneaux



A10440/ART5
6 anelli • ring • anneaux



A10440/ART6
6 anelli • ring • anneaux



A10440/ART8
6 anelli • ring • anneaux



code	taille/size	descrizione/description/description	colour	euro
A10440/...	21x15x3,5 cm	<ul style="list-style-type: none"> • MINI DIVE LOG ART 6 ANELLI porta penna, tasca porta documenti, porta brevetti (senza libretto immersioni) • MINI DIVE LOG ART 6 RINGS pen holder, document pocket, diving licence pocket (dive pages not included) • CARNET DE PLONGEE MINI porte-stylo, pochette à documents, support de brevet (sans livret de plongée) 		39,50

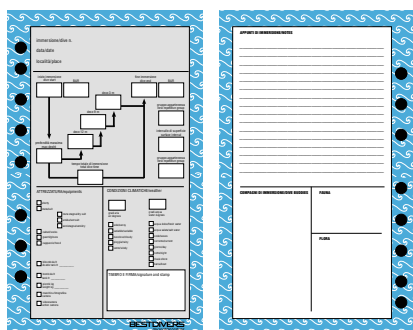

A10441U



A10441M



code	taille/size	descrizione/description/description	colour	euro
A10441U	-	<ul style="list-style-type: none"> • BLOCCHETTO 24 IMMERSIONI 3/6 fori italiano/inglese • NOTE BOOK 24 DIVES 3/6 hole Italian/english • CARNET 24 PLONGÉES 3/6 anneaux italien/anglais 		12,00
A10441M	-	<ul style="list-style-type: none"> • BLOCCHETTO MINI 24 IMMERSIONI 6 fori italiano/inglese • MINI NOTE BOOK 24 DIVES 6 hole Italian/english • CARNET 24 PLONGÉES 3/6 anneaux italien/anglais 		10,00



AI0445



AI0445/1



AI0444



code	taille/size	descrizione/description/description	colour	euro
AI0445	-	<ul style="list-style-type: none"> • WET NOTE STANDARD 45 pagine, copertina PVC, libretto appunti, fogli in carta impermeabile, matita • WET NOTE STANDARD PVC cover, 45 pages note pad, waterproof paper, pencil • CARNET RESISTANT A L'EAU STD 45 pages, couverture en pvc, carnet de notes, papier imperméable, crayon à papier 		36,50
AI0445/1	-	<ul style="list-style-type: none"> • INTERNO WET NOTE fogli in carta impermeabile, matita • WET NOTE SPARE PAGES waterproof paper, pencil • CARNET RECHARGE papier imperméable, crayon 		21,50
AI0444	-	<ul style="list-style-type: none"> • WET NOTE DELUXE 45 pagine, copertina PVC, libretto appunti, fogli in carta impermeabile, matita • WET NOTE DELUXE PVC cover, 45 pages note pad, waterproof paper, pencil • CARNET WET NOTE DE LUXE 45 pages, couverture en pvc, carnet de notes, papier imperméable, crayon à papier 		39,00



AI0446



AI0446/1



AI0431

code	taille/size	descrizione/description/description	colour	euro
AI0446	-	<ul style="list-style-type: none"> • WET NOTE TOP con tabelle, 45 pagine, copertina tessuto, libretto appunti, fogli in carta impermeabile, matita • WET NOTE TOP with tables, 45 pages, tissue cover, note pad, waterproof paper, pencil • WET NOTE TOP avec tableaux, 45 pages, couverture en toile, carnet de notes, feuilles de papier imperméable, crayon à papier 	-	65,50
AI0446/1	-	<ul style="list-style-type: none"> • INTERNO WET NOTE TOP con tabelle, fogli in carta impermeabile, matita, 45 pagine • WET NOTE TOP PAGES with tables, 45 pages, waterproof paper, pencil • PAGES DE RECHARGE POUR WET NOTE avec tableaux, feuilles de papier imperméable, crayon, 45 pages 	-	39,00
AI0431	-	<ul style="list-style-type: none"> • LIBRETTO STANDARD dive log standard, 40 immersioni, italiano • STANDARD PAGES standard dive log, 40 dives, italian • PAGES STANDARD carnet de plongée standard, 40 plongées, italien 	-	10,00



code	taille/size	descrizione/description/description	colour	euro
AI0430	8,5x13x1 cm 14 pcs	<ul style="list-style-type: none"> • DIVE LOG STANDARD copertina Best Divers in PVC con libretto 40 immersioni, italiano • STANDARD DIVE LOG Best Divers PVC cover with 40 dive pages included, Italian 		-
AI0430/S	8,5x13x1 cm 1 pc	<ul style="list-style-type: none"> • CARNET DE PLONGEE STANDARD couverture PVC Best Divers avec livret de 40 plongées, italien 		19,00



AI0401



AI0400

St. Mrs

code	taille/size	descrizione/description/description	colour	euro
AI0401	11x 10 cm	<ul style="list-style-type: none"> • LAVAGNA DA POLSO MULTIPLA 3 tabelle sovrapposte, apertura facilitata, fissaggio con elastico e velcro, matita, logo Best Divers • MULTI-PAGE WRIST SLATE 3 pages, with elastic and velcro fixing, easy opening, pencil, Best Divers logo • ARDOISE POIGNET MULTIPLE 3 volets, ouverture facile, fermeture élastique et velcro, crayon, logo Best Divers 	<input type="checkbox"/>	33,50
AI0400	10,5x 10 cm	<ul style="list-style-type: none"> • LAVAGNA DA POLSO MULTIPLA 3 tabelle sovrapposte, fissaggio con elastico e velcro, matita, logo Best Divers • MULTI-PAGE WRIST SLATE 3 pages, with elastic and velcro fixing, pencil, Best Divers logo • ARDOISE POIGNET MULTIPLE 3 tables superposées, fixation élastique et velcro, crayon, logo Best Divers 	<input type="checkbox"/>	



AI0427



AI0410/S



AI0420/S

St. Mrs

code	taille/size	descrizione/description/description	colour	euro
AI0427	15x20 cm	<ul style="list-style-type: none"> • LAVAGNA GRANDE matita, gomma, logo Best Divers • BIG SLATE pencil, rubber, Best Divers logo • GRANDE ARDOISE crayon, gomme, logo Best Divers 	<input type="checkbox"/>	18,50
AI0410/S	13x15 cm	<ul style="list-style-type: none"> • LAVAGNA BASIC QUICK clip fissaggio, matita, gomma, logo Best Divers • QUICK BASIC SLATE fixing clip, pencil, rubber, Best Divers logo • BASIQUE QUICK ARDOISE pince de fixation, crayon, gomme, logo Best Divers 	<input type="checkbox"/>	17,50
AI0420/S		<ul style="list-style-type: none"> • LAVAGNA BASIC matita, gomma, logo Best Divers • BASIC SLATE pencil, rubber, Best Divers logo • BASIQUE ARDOISE crayon, gomme, logo Best Divers 	<input type="checkbox"/>	15,00



AI0620
TARTARUGA
TURTLE
TORTUE



AI0622
RANA
FROG
GRENOUILLE



AI0616
PALOMBARO
DIVER
SCAPHANDRIER



AI0617
PINNE
FINS
PALMES



AI0618
ANCORA
ANCHOR
ANCRE



AI0633
DELFINO
DOLPHIN
DAUPHIN



AI0615
BARRACUDA
BARRACUDAS
BARRACUDAS



AI0628
SIRENA
MERMAID
SIRENE



AI0621
SUBACQUEO
DIVER
PLONGEUR



AI0632
BIBOMBOLA
DOUBLE TANK
BI-BOUILLE



AI0626
IPPOCAMPO
HIPPOCAMPUS
HIPPOCAMPE



AI0631
GRANCHIO
CRAB
CRABE



AI0627
PIRATA
PIRATE
PIRATE



AI0629
SQUALO
SHARK
REQUIN



AI0630
DANGEROUS
DIVERS
PLONGEUR
DANGEREUX



AI0619
SOTTOMARINO
SUBMARINE
SOUS MARIN



AI0625
CASCO
PALOMBARO
DIVER HELMET
CASQUE



AI0634
BOCCIA PESCI
FISH BOWL
POISSON



code	taille/size	descrizione/description/description	colour	euro
AI062...	-	<ul style="list-style-type: none"> • PORTACHIAVI portachiavi in gomma con anello INOX • KEYCHAINS rubber keychains with S:STEEL ring • PORTE CLE caoutchouc, avec anneau en acier inoxydable 		4,50



AI7000

AI7200

AI7100

code	taille/size	descrizione/description/description	colour	euro
AI7000		<ul style="list-style-type: none"> • BORRACCIA ALLUMINIO, squalo • SPORT WATER BOTTLE ALUMINIUM, shark • GOURDE DE SPORT ALUMINIUM, requin 		20,00
AI7200	Ø70 x 160 mm 500 ml	<ul style="list-style-type: none"> • BORRACCIA ALLUMINIO, cavalluccio • SPORT WATER BOTTLE ALUMINIUM, seahorse • GOURDE DE SPORT ALUMINIUM, hippocampe 		
AI7100		<ul style="list-style-type: none"> • BORRACCIA ALLUMINIO, tartaruga • SPORT WATER BOTTLE ALUMINIUM, turtle • GOURDE DE SPORT ALUMINIUM, tortue 		



AI6404



AI6411



AI6441



AI6402

code	taille/size	descrizione/description/description	colour	euro
AI6404		<ul style="list-style-type: none"> • MUG squalo • MUG shark • MUG requin 		11,50
AI6411	Ø80 x h 95 mm 0,33 cl	<ul style="list-style-type: none"> • MUG teschio messicano • MUG mexican skull • MUG crâne de mexicain 		
AI6441		<ul style="list-style-type: none"> • MUG texture pesci • MUG fish texture • MUG texture du poisson 		
AI6402		<ul style="list-style-type: none"> • MUG acquario • MUG acquariUS • MUG aquarium 		

**PERSONALIZZA CON IL TUO LOGO:
CUSTOMIZE WITH YOUR LOGO:
PERSONNALISER AVEC VOTRE LOGO:**



AR0934/P



AV0600P



code	taille/size	descrizione/description/description	colour	euro
AR0934/P	Ø 90x180 mm 30 pcs	<ul style="list-style-type: none"> • PORTA COMPUTER PERSONALIZZABILE imbottito • CUSTOMIZED COMPUTER BAG padded • POCHETTE MATELASSEE POUR ORDINATEUR PERSONNALISE rembourré 		22,50
AV0600P	88x58 cm 15 pcs	<ul style="list-style-type: none"> • BORSA MUTA PERSONALIZZABILE borsa NYLON per trasporto muta, utilizzabile anche come tappetino • CUSTOMIZED SUIT/MAT BAG NYLON bag for wetsuit, can be used as mat • TAPIS PERSONNALISE sac en NYLON pour le transport des combinaisons de plongée, peut également être utilisé comme tapis 		46,50



AR0844



AR0971



code	taille/size	descrizione/description/description	colour	euro
AR0844	42X42 cm 30 pcs	<ul style="list-style-type: none"> • SACCHETTO PORTA EROGATORE PERSONALIZZABILE poliestere BIANCO • REGULATOR BAG customized WHITE polyester • SAC DETENDEUR PERSONNALISE BLANC polyester 		19,00
AR0971	22x115 mm 30 pcs	<ul style="list-style-type: none"> • SACCA PORTA PINNE PERSONALIZZABILE POLY 600, 500 gr, con tracolla • CUSTOMIZED APNEA FIN BAG POLY 600, 500 gr BLACK with shoulder strap • SAC PALMES APNEE PERSONNALISEE POLY 600, 500 g, avec bandoulière 		46,50



code	taille/size	descrizione/description/description	colour	euro
AB0595P	100 pcs	<ul style="list-style-type: none"> • KIT OR CON SCATOLA PERSONALIZZABILE scatola NYLON, stampa 1 colore • CUSTOMIZED KIT OR WITH BOX NYLON box, 1 colour prin • KIT JOINTS BOITE PERSONNALISEE boîte en NYLON, en 1 couleur 		19,00

PERSONALIZZA CON IL TUO LOGO O LA TUA FOTOGRAFIA:
 CUSTOMIZE WITH YOUR LOGO OR PHOTO:
 PERSONNALISER AVEC VOTRE LOGO OU VOTRE PHOTO:



code	taille/size	descrizione/description/description	colour	euro
A10441/ P6S	26x18x5 cm 15 pcs	<ul style="list-style-type: none"> • DIVE LOG PERSONALIZZABILE 6 ANELLI, porta penna, tasca porta documenti, porta brevetti (senza libretto immersioni) • CUSTOMIZED DIVE LOG 6 RING, pen holder, document pocket, diving licence pocket (dive pages not included) • CARNET DE PLONGEE PERSONNALISE 6 ANNEAUX, porte-stylo, pochette à documents, support de brevet (sans livret de plongée) 		45,00
A10441/ P3S		<ul style="list-style-type: none"> • DIVE LOG PERSONALIZZABILE 3 ANELLI, porta penna, tasca porta documenti, porta brevetti (senza libretto immersioni) • CUSTOMIZED DIVE LOG 3 RING, pen holder, document pocket, diving licence pocket (dive pages not included) • CARNET DE PLONGEE PERSONNALISE 3 ANNEAUX, porte-stylo, pochette à documents, support de brevet (sans livret de plongée) 		

**PERSONALIZZA CON IL TUO LOGO O LA TUA FOTOGRAFIA:
CUSTOMIZE WITH YOUR LOGO OR PHOTO:
PERSONNALISER AVEC VOTRE LOGO OU VOTRE PHOTO:**



code	taille/size	descrizione/description/description	colour	euro
AR0954		<ul style="list-style-type: none"> • BORSELLO PERSONALIZZABILE RETTANGOLARE, polistere 600, coperchio COLORATO • REGULATOR BAG CUSTOMIZED RECTANGULAR, polyester 600, COLOURED bottom • SACOCHÉ PERSONNALISABLE RECTANGULAIRE polyester 600, fond de couleur 		36,00
AR0954B	34x25x12 cm 15 pcs	<ul style="list-style-type: none"> • BORSELLO PERSONALIZZABILE RETTANGOLARE, polistere 600, coperchio BIANCO • REGULATOR BAG CUSTOMIZED RECTANGULAR, polyester 600, WHITE bottom • SACOCHÉ PERSONNALISABLE RECTANGULAIRE polyester 600, fond blanc 		
AR0954/I		<ul style="list-style-type: none"> • BORSELLO PERSONALIZZABILE RETTANGOLARE, polistere 600, coperchio BIANCO, padded • REGULATOR BAG CUSTOMIZED RECTANGULAR, polyester 600, WHITE bottom, padded • SACOCHÉ PERSONNALISABLE RECTANGULAIRE polyester 600, fond blanc, rembourré 		50,50

**PERSONALIZZA CON IL TUO LOGO O LA TUA FOTOGRAFIA:
CUSTOMIZE WITH YOUR LOGO OR PHOTO:
PERSONNALISER AVEC VOTRE LOGO OU VOTRE PHOTO:**



code	taille/size	descrizione/description/description	colour	euro
AR0953		<ul style="list-style-type: none"> • BORSELLO PERSONALIZZABILE TONDO, polistere 600 fondo colorato • REGULATOR BAG CUSTOMIZED ROUND, polyester 600 coloured bottom • SACOCHÉ PERSONNALISABLE RONDE polyester 600, fond de couleur 		35,00
AR0953B	Ø 29x15 cm 15 pcs	<ul style="list-style-type: none"> • BORSELLO PERSONALIZZABILE TONDO, polistere 600 fondo BIANCO • REGULATOR BAG CUSTOMIZED ROUND, polyester 600 WHITE bottom • SACOCHÉ PERSONNALISABLE RONDE polyester 600, fond blanc 		
AR0953/I		<ul style="list-style-type: none"> • BORSELLO PERSONALIZZABILE TONDO, polistere 600 fondo BIANCO, imbottito • REGULATOR BAG CUSTOMIZED ROUND, polyester 600 WHITE bottom, padded • SACOCHÉ PERSONNALISABLE RONDE polyester 600, fond blanc, rembourré 		49,00

**PERSONALIZZA CON IL TUO LOGO O LA TUA FOTOGRAFIA:
CUSTOMIZE WITH YOUR LOGO OR PHOTO:
PERSONNALISER AVEC VOTRE LOGO OU VOTRE PHOTO:**





code	taille/size	descrizione/description/description	colour	euro
A16400	Ø80 x H 95 mm 0,33 cl, 11 OZ 12 pcs	<ul style="list-style-type: none"> • MUG PERSONALIZZABILE • CUSTOMIZED MUG • MUG PERSONNALISABLE 		11,50

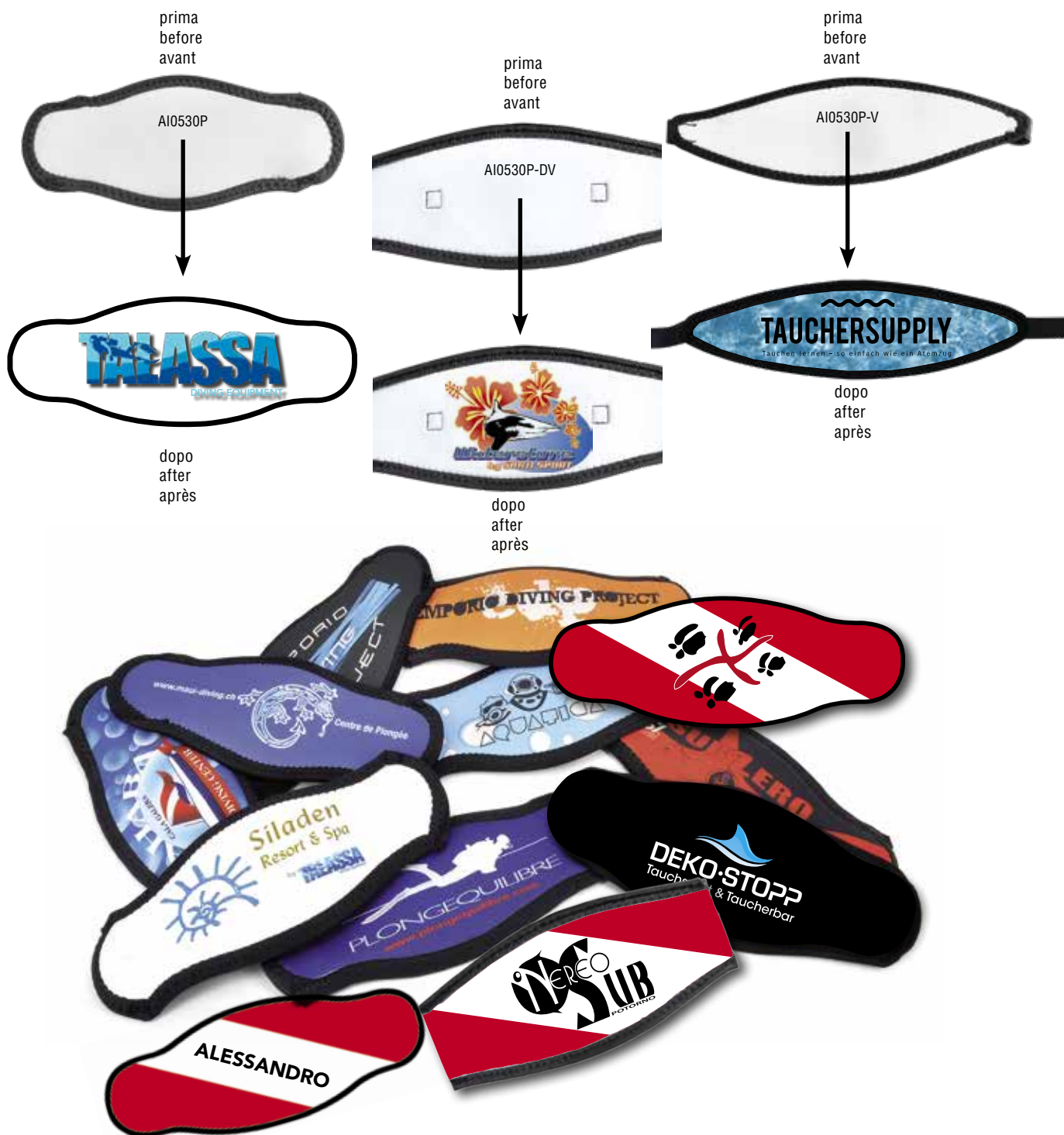

code	taille/size	descrizione/description/description	colour	euro
A17400P	Ø70 x 160 mm 500 ml 12 pcs	<ul style="list-style-type: none"> • BORRACCIA PERSONALIZZABILE ALLUMINIO • CUSTOMIZED SPORT WATER BOTTLE ALUMINIUM • GOURDE DE SPORT PERSONNALISABLE ALUMINIUM 		20,00

**PERSONALIZZA CON IL TUO LOGO O LA TUA FOTOGRAFIA:
CUSTOMIZE WITH YOUR LOGO OR PHOTO:
PERSONNALISER AVEC VOTRE LOGO OU VOTRE PHOTO:**



code	taille/size	descrizione/description/description	colour	euro
 AI0530P		• FASCE NEOPRENE PERSONALIZZABILI neoprene a doppio foglio • MASK STRAPS CUSTOMIZED neoprene double layer • SANGLES MASQUE PERSONNALISABLE neoprene double épaisseur		
 AI0530P-V	50 pcs	• FASCE NEOPRENE PERSONALIZZABILI neoprene con velcro • MASK STRAPS CUSTOMIZED neoprene with velcro • SANGLES MASQUE PERSONNALISABLE neoprene vec Velcro		14,50
 AI0530-DV		• FASCE NEOPRENE PERSONALIZZABILI neoprene con doppio velcro • MASK STRAPS CUSTOMIZED neoprene with double velcro • SANGLES MASQUE PERSONNALISABLE neoprene adouble velcro		

ENTRA NEL MONDO INCANTATO DI BEST DIVERS: **FACCIAMOCI ACCOMPAGNARE DAGLI AMICI**

ENTER THE MAGICAL WORLD OF BEST DIVERS:
LET US BE ACCOMPANIED BY FRIENDS
ENTREZ DANS LE MONDE MAGIQUE DE BEST DIVERS:
FAISONS-NOUS ACCOMPAGNER PAR DES AMIS



ULTRAMAX



UXDC16-AQ

UXDC16-RD

CARATTERISTICHE CUSTODIA • HOUSING FEATURES • CARACTÉRISTIQUES DES LOGEMENTS

- **MATERIALE** Policarbonato stabilizzato UV ad alto impatto • **MATERIAL** High impact UV stabilized Polycarbonate material
- **MATÉRIAU** Polycarbonate résistant aux chocs et stabilisé aux UV

- **PROFONDITA'** 60 m • **DEPTH** 60 m • **PROFONDITÉ** 60 m

- **LENTE** Lente in vetro temperato di 3,0 mm di spessore di tipo ottico • **LENS** Optical grade 3.0 mm thick tempered glass lens
- **LENTILLE** Lentille optique en verre trempé de 3,0 mm d'épaisseur

- **GUARNIZIONE** Doppie guarnizioni O-Ring in silicone • **SEAL** Double Silicone O-Ring seals
- **JOINTS** Double joint torique en silicone

- **LENSPORT** Filetto da 52 mm per lenti e filtri • **LENSPORT** 52 mm thread for lenses & filters
- **LENSPORT** Filetage de 52 mm pour objectifs et filtres

- **CINGHIOLO** Incluso • **STRAP** Included • **SANGLE** Inclus

- **SENSORE** 16MP CCD • **SENSOR** 16MP CCD • **SENSEUR** 16MP CCD

- **ZOOM** 5X

- **DISPLAY LCD** da 2,7" RIS. 230k

- **RISOLUZIONE REGISTRAZIONE HD** 720p 30 fps • **VIDEO RECORDING SOLUTION HD** 720p 30 fps HD 720p 30 fps
- **RESOLUTION D'ENREGISTREMENT HD** 720p 30 fps

- **BILANCIAMENTO DEL BIANCO** • **WHITE BALANCE SELECTION** • **BALANCE BLANCHE**

- **SCHEDA SD** • **SD CARD** • **CARTE SD**



- **BATTERIA** Ioni di litio 3.7v 700 mAh inclusa • **BATTERY** Lithium-ion battery 3.7v 700 mAh included
- **BATTERIE** Lithium-ion 3,7v 700 mAh incluse

- **CARICABATTERIE** Incluso • **CHARGING** Included • **CHARGEUR DE BATTERIES** inclus

- **CAVO USB** Incluso • **CABLE USB** Included • **CÂBLE USB** inclus

- **CUSTODIA** Incluso • **HOUSING** Included • **CASE** inclus

- **CAVO VIDEO** Incluso • **VIDEO CABLE** Included • **CÂBLE VIDÉO** inclus

code	taille/size	descrizione/description/description	colour	euro
UXDC16-AQ	16 MP 60 m	• ULTRAMAX DIGITAL CAMERA • APPAREIL PHOTO ULTRAMAX		364,00
UXDC16-RD				







UXMAGSP1



UXREDSP1



UXSPUV

code	taille/size	descrizione/description/description	colour	euro
UXSPAD16	Ø 52 mm	• ADATTATORE ULTRAMAX adattatore per filtri DC 16 • ADAPTER FILTER ULTRAMAX adapter for DC 16 filter • ADAPTATEUR ULTRAMAX pour les filtres DC 16		24,00
UXMAGSP1		• FILTRO MAGENTA per DC 16 ULTRAMAX • MAGENTA FILTER for DC 16 ULTRAMAX • FILTRE MAGENTA pour DC 16 ULTRAMAX		33,50
UXREDSP1		• FILTRO ROSSO per DC 16 ULTRAMAX • RED FILTER for DC 16 ULTRAMAX • FILTRE ROUGE pour DC 16 ULTRAMAX		33,50
UXSPUV		• FILTRO UV per DC 16 ULTRAMAX • UV FILTER for DC 16 ULTRAMAX • FILTRE UV pour DC 16 ULTRAMAX		13,50





UXSP1CUL



UXSPND2



UXSP006

code	taille/size	descrizione/description/description	colour	euro
UXSP1CUL	Ø 52 mm	• LENTE CLOSE UP per DC16 ULTRAMAX • CLOSE UP LENS for DC16 ULTRAMAX • LENTILLE DE FERMETURE pour DC16 ULTRAMAX		42,50
UXSPND2		• FILTRO NEUTRAL DENSITY per DC16 ULTRAMAX • NEUTRAL DENSITY FILTER for DC16 ULTRAMAX • FILTRE À DENSITÉ NEUTRE pour DC16 ULTRAMAX		21,00
UXSP006	5 pcs	• SILICA GEL sticker per DC16 ULTRAMAX • SILICA GEL sticker for DC16 ULTRAMAX • AUTOCOLLANT EN GEL DE SILICE pour DC16 ULTRAMAX	-	10,50

BECAM See...Shoot...Share... with BECAM you can.

ACTION CAMERA BECAM



Electronics Image Stabilizer

CARATTERISTICHE/FEATURES

• Colore • Colour • Couleur	• NERO OPACO • MATT • NOIR NERO MATT
• Sensore • Sensor • Capteur	1/3.2" 8.8MP Sony IMX179 CMOS
LCD:	2" LCD Display colours 320*240
• Risoluzione foto • Image resolution • Résolution des photos	20/16/12/8/5 Mega pixel
• Risoluzione video • Video resolution • Résolution vidéo	4K 3840*2160 @30 fps (no EIS) 4K 3200*1800 @25 fps (support EIS) 2.7K 2560*1440 @30 fps (support EIS) 1080P 1920x1080 @60/30 fps (support EIS) 720P 1080*720 @120/60 fps (support EIS)
• Formato video • Video format • Format vidéo	.MOV H264
• Formato immagine • Image format • Format de l'image	.JPG
• Grandangolo • Lens • Grand angle	170° HD wide-angle 6G+1/R glass optical
• WI-FI	• Sì • Yes • Oui
• Memoria • Memory • Mémoire	• Slot per • for Micro • Port pour SD • fino • up to • jusqu'à 32 GB
• Porta • Slot • Port	USB 2.0, HDMI
• Durata batteria • Battery life • Durée de vie de la batterie	120 • minuti • minutes • minutes (con wi-fi disattivato • when wi-fi OFF • avec le wi-fi désactivé)
• Batteria • Battery • Batterie	1x • ricaricabile • rechargeable • rechargeable 1200mAh
• Peso • Weight • Poids	44 g • senza batteria • without battery • sans batteries 58 g • con batteria • with battery • avec battery
• Dimensioni • Dimensions • Dimensions	25x60x41 mm
• Profondità • Depth • Profondeur	50 m
• Filtri • Filters • Filtres	• rosso per acqua blu • red for blue water • rouge pour l'eau bleue • magenta l'acqua verde • magenta for green water • magenta pour l'eau vert



code	taglia/size	descrizione/description/description	colour	euro
AC4500	25x60x41 mm	<ul style="list-style-type: none"> • ACTION CAMERA "BECAM EIS" contenuto: action camera 4K, scafandro 50 m, 1 batteria, filtro rosso, filtro magenta, custodia imbottita, cavo USB, adattatore trepiede • ACTION CAMERA "BECAM EIS" contents: action camera 4K, waterproof housing 50 m, 1 battery, red filter, magenta filter, padded shockproof case, USB cable, tripod adapter • ACTION CAMERA "BECAM EIS" contenu: action camera 4K, boitier 50 m, 1 batterie, filtre rouge, filtre magenta, cable USB, étui, adaptateur tripode 	■	191,50

St. Mrs



AC0400CST



AC0500HOU



AC0300E

code	taille/size	descrizione/description/description	colour	euro
AC0400CST	50 m	<ul style="list-style-type: none"> • CUSTODIA BECAM custodia subacquea • HOUSING BECAM waterproof housing • BOITIER BECAM boîtier sous-marin 	-	79,50
AC0500HOU	200 m	<ul style="list-style-type: none"> • CUSTODIA "BECAM DEEP" custodia subacquea • HOUSING "BECAM DEEP" waterproof housing • BOITIER "BECAM DEEP" boîtier sous-marin 	■	277,50
AC0300E	-	<ul style="list-style-type: none"> • CAMERA "BECAM EIS" solo camera 4K • INNER CAMERA "BECAM EIS" inner camera 4K • BOITIER BECAM EIS uniquement camera 4K 	■	156,00



AC026



AC027

code	taille/size	descrizione/description/description	colour	euro
AC026	60 m	<ul style="list-style-type: none"> • FILTRO ROSSO "ELITE" per acqua blu, frame in alluminio, per GoPro®3/4/5N • RED FILTER "ELITE" for blue water, aluminium frame, compatible with GoPro®3/4/5 • FILTRE ROUGE "ELITE" pour l'eau bleue, cadre en aluminium, pour GoPro®3/4/5N 	■	52,00
AC027	60 m	<ul style="list-style-type: none"> • FILTRO MAGENTA "ELITE" per acqua verde, frame in alluminio, per GoPro®3/4/5 • MAGENTA FILTER "ELITE" for green water, aluminium frame, compatible with GoPro®3/4/5 • FILTRE MAGENTA "ELITE" pour l'eau vert, cadre en aluminium, pour GoPro®3/4/5N 	■	





AC029M

code	taille/size	descrizione/description/description	colour	euro
AC029M	M 58 mm	<ul style="list-style-type: none"> • LENTE MACRO per riprese da 0-45 cm • MACRO LENS video recording up to 45 cm • LENTILLE MACRO pour les séquences de da 0-45 cm 	□	113,00



AC028

AC029

code	taille/size	descrizione/description/description	colour	euro
AC028	60 m	<ul style="list-style-type: none"> • FILTER SET filtri "ELITE" ROSSO + MAGENTA, frame in ALLUMINIO, adattabile per custodie GoPro® 3/4/5 • FILTER SET filters "ELITE" RED + MAGENTA, ALUMINIUM frame, compatible with GoPro® housing 3/4/5 • FILTRE SET filters "ELITE" ROUGE + MAGENTA, cadre en aluminium, pour GoPro® 3/4/5 		97,50
AC029	60 m	<ul style="list-style-type: none"> • FILTER SET filtro "ELITE" ROSSO + ghiera macro, frame in ALLUMINIO, adattabile per custodie GoPro® 3/4/5 • FILTER SET filter "ELITE" RED + MACRO ring ALUMINIUM frame, compatible with GoPro® housing 3/4/5 • FILTRE SET filtres "ELITE" ROUGE + MAGENTA, cadre en aluminium, pour GoPro® 3/4/5 		78,00





VD032



VD051



VD023

code	taille/size	descrizione/description/description	colour	euro
VD032	150 mm x Ø 38 mm	<ul style="list-style-type: none"> • IMPUGNATURA impugnatura NYLON, galleggiante • HAND GRIP NYLON floating hand grip • POIGNEE PLASTIQUE, flottante 		11,50
VD051	315 mm-1000 mm	<ul style="list-style-type: none"> • IMPUGNATURA ESTENSIBILE ALLUMINIO, vite INOX per fissaggio fotocamera o videocamera • EXTENSION POLE ALUMINIUM, S.STEEL screw, for camera or videocamera • POIGNEE aluminium, vis en acier inoxydable pour la fixation d'un appareil photo 		38,00
VD023	1/4"	<ul style="list-style-type: none"> • ADATTATORE TREPIEDE per action camera • TRIPOD ADPTER for action camera • ADAPTATEUR POUR TRÉPIED pour action camera 		4,00



F0964



F0963



F0962



F0967

code	taille/size	descrizione/description/description	colour	euro
F0964	Ø 34 mm, 24 cm	<ul style="list-style-type: none"> • BRACCIO SNODATO con imbottitura • FLEX ARM soft grip • BRAS FLEX avec joint de tête flash, avec mousse 	■	58,50
F0963	Ø 26 mm, 24 cm	<ul style="list-style-type: none"> • BRACCIO SNODATO universale • FLEX ARM universal • BRAS FLEX avec joint tete flash 		41,50
F0962	Ø 26 mm, 24 cm attacco/ thread 1/4"	<ul style="list-style-type: none"> • BRACCIO SNODATO • FLEX ARM • BRAS FLEX 		51,50
F0967	Ø 34 mm, 30 cm	<ul style="list-style-type: none"> • BRACCIO SNODATO universale • FLEX ARM universal • BRAS FLEX universelle 		45,50



F0974



F0970



F0969



F0971

code	taille/size	descrizione/description/description	colour	euro
F0974	6,5 cm	<ul style="list-style-type: none"> • BRACCIO FISSO alluminio anodizzato • BALL JOINT ARM anodized aluminum • BRAS aluminium anodisé 	■	18,50
F0969	15 cm			34,00
F0970	20 cm			41,50
F0971	30 cm			49,50



F0120



F0280

code	taille/size	descrizione/description/description	colour	euro
F0120	12 cm	<ul style="list-style-type: none"> • STAFFA alluminio anodizzato, per secondo flash • BRACKET anodized aluminium, for second flash • SUPPORT aluminium anodisé, pour le second flash 	■	24,50
F0280	28 cm	<ul style="list-style-type: none"> • STAFFA alluminio anodizzato, staffa principale flash con base e vite di fissaggio macchina fotografica • BRACKET anodized aluminium, flash mount bracket with base and camera mount screw • SUPPORT aluminium anodisé, support de flash principal avec base et vis de fixation à l'appareil photo 		58,50



VD580



VD581

code	taille/size	descrizione/description/description	colour	euro
VD580	155x105 mm	<ul style="list-style-type: none"> • STAFFA MINI ACTION CAMERA alluminio, con predisposizione per 2 bracci snodati • MINI ACTION CAMERA ARM aluminium, intended for 2 flex arms • SUPPORT MINI ACTION CAMERA en aluminium, avec possibilité de 2 bras articulés 	■	61,50
VD581	125x105 mm	<ul style="list-style-type: none"> • STAFFA MINI ACTION CAMERA alluminio, con predisposizione per 1 braccio snodato • MINI ACTION CAMERA ARM aluminium, intended for 1 flex arm • SUPPORT MINI ACTION CAMERA en aluminium, avec possibilité d'un bras articulé 		51,50



VD583



VD582

code	taille/size	descrizione/description/description	colour	euro
VD583	135-175x105 mm	<ul style="list-style-type: none"> • STAFFA ACTION CAMERA REGOLABILE alluminio, con predisposizione per 2 bracci snodati • ADJUSTABLE ACTION CAMERA ARM aluminium, intended for 2 flex arms • SUPPORT ACTION CAMERA AJUSTABLE en aluminium, avec possibilité de 2 bras articulés 	■	118,50
VD582	140-160x105 mm	<ul style="list-style-type: none"> • STAFFA ACTION CAMERA REGOLABILE alluminio, con predisposizione per 1 braccio snodato • ADJUSTABLE ACTION CAMERA ARM aluminium, intended for 1 flex arm • SUPPORT ACTION CAMERA AJUSTABLE en aluminium, avec possibilité d'un bras articulé 		83,50



code	taille/size	descrizione/description/description	colour	euro
F0972	Ø 2,5 mm	<ul style="list-style-type: none"> • CLAMP ALLUMINIO, chiusura a farfalla 2 fori • CLAMP ALUMINIUM, 2 section ball joint clamp • CLAMP 2 sections collier de serrage alu 	■	43,00
F0973	Ø 2,5 mm	<ul style="list-style-type: none"> • CLAMP ALLUMINIO, chiusura a farfalla 3 fori • CLAMP ALUMINIUM, 3 section ball joint clamp • CLAMP 3 sections collier de serrage alu 		76,00
F0092	filetto/ thread 1/4"	<ul style="list-style-type: none"> • ADATTATORE per braccio snodato • ADAPTER for flex arm • ADAPTATEUR pour flex bras 		67,00
F0977	-	<ul style="list-style-type: none"> • "C" CONNECTOR per bracci snodati • "C" CONNECTOR for flex arms • CONNECTEUR "C" for flex bras 		15,50



code	taille/size	descrizione/description/description	colour	euro
F0091	Ø 29 mm	<ul style="list-style-type: none"> • ADATTATORE PER TORCIA fisso per braccio flash • TORCH ADAPTER fixed for flash arm • TORCHE/FLASH ADAPTATEUR fixe 	■	63,50
F0010	-	<ul style="list-style-type: none"> • VOLANTINO ACCIAIO INOX vite per il fissaggio della testa flash o degli adattatori alle staffe • S.STEEL SCREW to fix flash head/adapters to adjustable mount bracket snodate • VIX INOX vis pour fixer la tête du flash ou les adaptateurs aux supports 		13,00
F0095	Ø 26-29 mm	<ul style="list-style-type: none"> • ADATTATORE PER TORCIA rotazione 360° per braccio flash • TORCH ADAPTER for arm/torch, rotation 360° • TORCH/FLASH ADAPTATEUR Rotation de 360° pour le bras du flash 		51,00
MD96/369	Ø 22 mm	<ul style="list-style-type: none"> • ADATTATORE PER TORCIA per braccio flash • TORCH ADAPTER flash arm adapter • ADATTATORE PER TORCIA pour bras de flash 		28,00



code	taille/size	descrizione/description/description	colour	euro
MD96/367	Ø 26 mm	<ul style="list-style-type: none"> • ADATTATORE PER TORCIA per braccio flash • ADAPTATEUR flash arm adapter • ADAPTATEUR flex bras/torche 	■	28,00
MD96/375	Ø 30 mm			
F0090	Ø 26-29 mm	<ul style="list-style-type: none"> • ADATTATORE PER TORCIA rotazione 360° per staffa videocamera/flash • TORCH ADAPTER flex adapter, for arm/torch, rotation 360° • ADAPTATEUR flex bras/torche 		51,00
F0975	-	<ul style="list-style-type: none"> • BASE PER BRACCETTO alluminio, braccio per staffa videocamera/flash • BASE FOR BALL JOINT ARM aluminium, ball joint arm for flash/camera brackets • ADAPTATEUR aluminium, bras de support de caméra/flash 		27,00
F0961	-	<ul style="list-style-type: none"> • MINI BRACCIO per testa flash o adattatori torcia, per staffa videocamera/flash • MINI ARM for flash head or torch adapter, for flash/camera brackets • ADAPTATEUR pour adaptateurs de tête de flash ou de torche, pour support de caméra/flash 	23,00	

VD014



VD015



code	taille/size	descrizione/description/description	colour	euro
VD014	-	<ul style="list-style-type: none"> • CINGHIOLO TESTA fascia elastica per fissaggio su testa • HEAD MOUNT adjustable head strap moun • SUPPORT TETE REGLABLE bandeau élastique 	■	13,00
VD015	-	<ul style="list-style-type: none"> • IMBRAGO PETTO fascia elastica per fissaggio su petto • CHEST STRAP adjustable chest strap for camera • SUPPORT POITRINE REGLABLE bandeau élastique 		16,50

VD550



code	taille/size	descrizione/description/description	colour	euro
VD550	360°	<ul style="list-style-type: none"> • GUANTO ACTION CAMERA rotazione 360° • ACTION CAMERA GLOVE rotating 360° • GANT AVEC SUPPORT TOTATIF rotation à 360° 	■	15,50

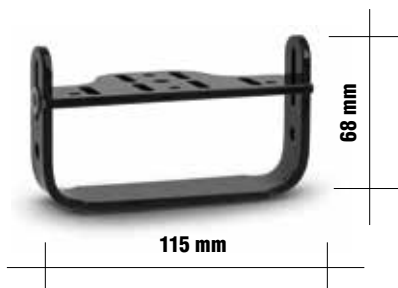

code	taille/size	descrizione/description/description	colour	euro
VD560	115x68 mm	<ul style="list-style-type: none"> • MANIGLIA GOODMAN ALLUMINIO anodizzato, regolabile per fissaggio torce, action camera, teste speleo • GOODMAN HANDLE anodized ALUMINIUM, adjustable, to fix torches, action cameras, speleo heads • POIGNÉE GOODMAN aluminium anodisé, réglable pour fixer des torches, des caméras d'action, des têtes de spéléologie 	■	67,00



BH620



BH614



VD450

code	taille/size	descrizione/description/description	colour	euro
BH620	15 mm, 2 pcs	<ul style="list-style-type: none"> • VITE "FOTOGRAFICA" volantino NYLON, vite lunga INOX 1/4 • PHOTOGRAPHIC SCREW for videocamera arms, S.STEEL 1/4 • VIS volant NYLON, vis longue INOX 1/4 	■	17,50
BH614	10 mm, 2 pcs	<ul style="list-style-type: none"> • VITE "FOTOGRAFICA" volantino NYLON, vite corta INOX 1/4 • PHOTOGRAPHIC SCREW or videocamera arms, S.STEEL 1/4 • VIS volant NYLON, vis court INOX 1/4 		15,50
VD450	-	<ul style="list-style-type: none"> • VITE "FOTOGRAFICA" INOX 1/4" rondella gomma • PHOTOGRAPHIC SCREW S.STEEL 1/4" rubber washer • VIS Rondelle en caoutchouc 1/4" INOX 		14,50

ENTRA NEL MONDO INCANTATO DI BEST DIVERS: **IL DUBBIO È L'INIZIO DELLA CONOSCENZA.**

ENTER THE MAGICAL WORLD OF BEST DIVERS:

DOUBT IS THE ORIGIN OF WISDOM

ENTREZ DANS LE MONDE MAGIQUE BEST DIVERS:

LE DOUTE EST LE COMMENCEMENT DE LA SAGESSE



ENTRA NEL MONDO INCANTATO BEST DIVERS
ENTER THE MAGICAL WORLD OF BEST DIVERS
ENTREZ DANS LE MONDE MAGIQUE DE BEST DIVERS

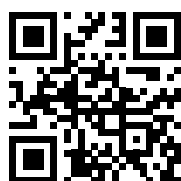

copertina catalogo
catalogue cover
couverture du catalogue
ANNA RIZZI ILLUSTRATRICE
art director Donatella Carretta
2024