

Specification Standard Sheet		
Shell Test Pressure	6.0	MPa
High Pressure Seal Test	4.4	
Low Pressure Seal Test	0.6	
Suitable Temperature	-10~400°C	
Suitable Medium	Water, Steam, Oil etc	

Size	Main Dimension(mm)									
DN	d	D	D1	D2	b	f	n- ϕ d	L	H	ϕ W
250	250	450	385	345	38	3	12- ϕ 33	730	790	450

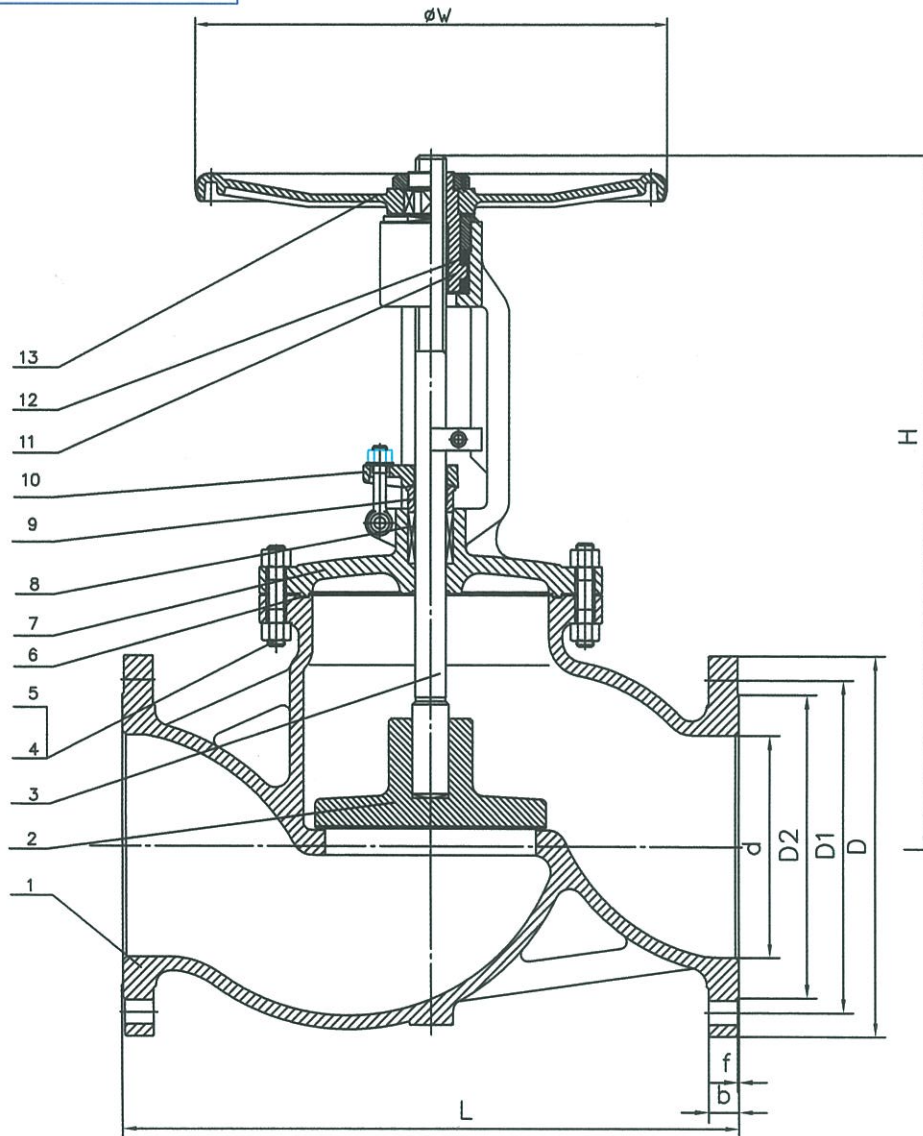

13	Hand Wheel	ASTM A536 60-40-18	
12	Plane Bearing	Commodity	
11	Stem Nut	Copper alloy	
10	Gland Flange	DIN 17245 GS-C25	
9	Gland	ASTM A276 410	
8	Stem Packing	Flexible Graphite	
7	Bonnet	DIN 17245 GS-C25	
6	Gasket	Graphite+SS304	
5	Bonnet Nut	ASTM A194 2H	
4	Bonnet Bolt	ASTM A193 B7	
3	Stem	ASTM A182 F6a	
2	Disc	DIN 17245 GS-C25+13Cr	
1	Body	DIN 17245 GS-C25+13Cr	

No	Parts Name	Parts Material	Remarks
GLOBE CHECK VALVE PN40 RF			
Design and Manufacture		BS EN 13709	
Face to Face Dimensions		DIN 3202-F1	
Flange Ends Dimensions		DIN EN 1092-1	
Inspection and Test		BS EN 12266	
MVS(EXPORT) LTD			