

1x1, 1x2, 2x2, with state monitor (MO Series)

Overview

The MO-series are opto-mechanical latching switches for the most demanding applications in fiber optic communication networks. The switch is available in 1x1, 2x1 and 2x2 variants and offers solid state reliability, accurate precision and fast response time. The switch mechanism has a very fast response time below 1 ms and below 0.9 dB insertion loss.

The small package withstands rugged environments and is well suited for direct mounting on printed circuit boards. The switch is qualified according to Telcordia GR 1221. The latching variant is available with an integrated state sensor which gives a read-out of the switch position for self test and monitoring.

Features

- reliable
- 1 ms speed
- latching
- capacitive state sensor
- 2x2, 2x1, 1x1 variants

Applications

- Protection Switching
- Reconfiguration
- WDM

Description

The Mems-Switches are powered by a 4.75 – 5.25 V voltage on the supply pin. To set the state of the switch TTL or CMOS logic levels are applied on the selector pins: When the logic level on bar selector pin 2 is set to high (5V) for at least 2 ms, the switch toggles into the bar state. To set the cross state a HIGH pulse is applied on pin 3. At rest pin 1 to 4 should be set to a defined potential.

A capacitive sensor allows to read out the switch position. The sensor's output is a pulled-up collector. The sensor output is LOW (0V) in cross and HIGH (5V) in bar state. During setting of the switch, i.e. when either pin 2 or 3 are high, the capacitive sensor is disabled and doesn't reflect the physical switch state. Technology by Sercalo.

BAR STATE (Sensor = 5 V)

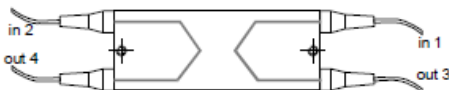

CROSS STATE (Sensor = 0 V)



1x1, 1x2, 2x2, with state monitor (MO Series)

Technical Specifications

	Unit	Min	Typ	Max
Optical Switch				
Wavelength Range	nm	1240		1640
Insertion Loss	dB		0,4	0,9 ¹
Crosstalk	dB		75	60
Back reflection	dB		55	50
Polarisation Dependent Loss	dB		0,03	0,07
Repeatability ²	dB			0,002
Switching Time	ms		0,5	1
Fiber Pigtail	µm		9/125/900	
Durability	cycles		no wear out	
Integrated Driver				
Supply Voltage Vcc	V	4,75	5	5,25
Current Consumption Icc	mA		2	10
Current sink Sensor Isensor	mA			10
Logic Level Low (BR and CR select)	V			0,5
Logic Level High (BR and CR select)	V	3		
Selection Pulse Width	ms	2		
Package				
Operation Temperature	°C	0		70
Storage Temperature	°C	-40		85
Size (L x W x H)	mm		43 x 16,5 x 9,5	

¹ value excluding connectors. Add 0.25 dB to account for temperature and wavelength dependent loss.

² value for constant temperature and polarisation

PIN Location and Outline

PIN Location and Outline (dimensions in mm)

- 1 5 V supply
- 2 bar select
- 3 cross select
- 4 ground 0 V
- 5 sensor output
- 6 sensor output

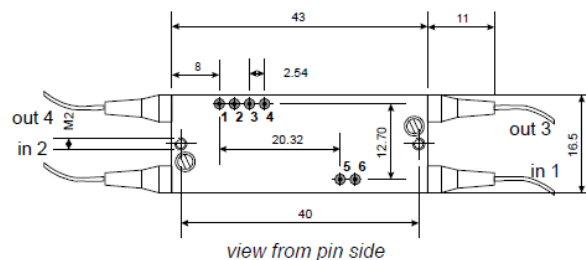

Electrical Schematic Diagram

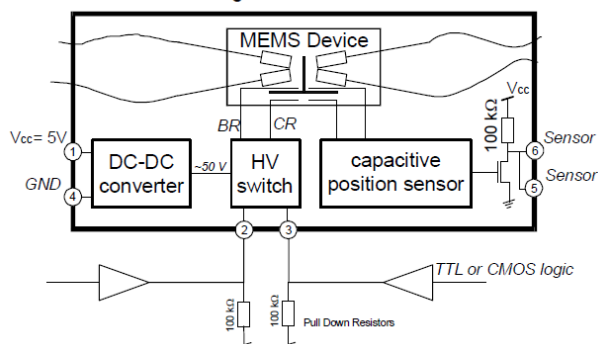

1x1, 1x2, 2x2, with state monitor (MO Series)

Ordering Information

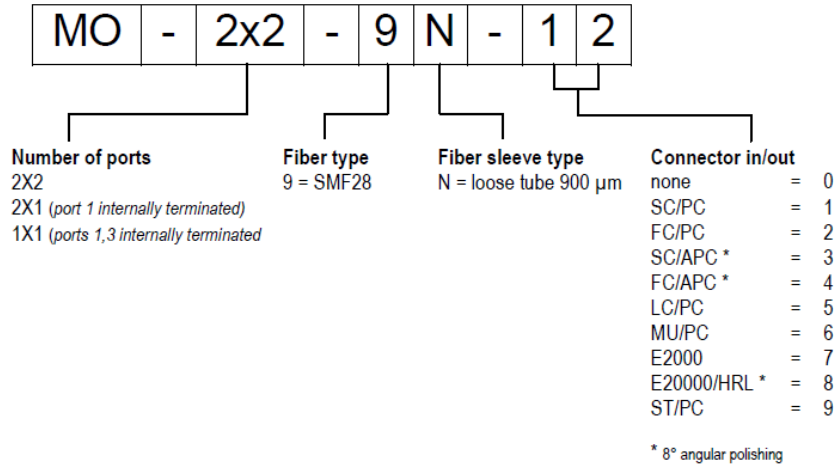

HUBER+SUHNER Cube Optics AG
 Eindhoven-Allee 3
 55129 Mainz, Germany

+49-6131-4995-100
 sales.cubo@hubersuhner.com

www.hubersuhner.com
 www.cubeoptics.com