

## 1x1, 1x2, 2x2, miniaturized (MI Series)

### Overview

The MI-series are miniature opto-mechanical switches for fiber optic communication systems and sub-modules. The switch is available in latching or non-latching variants, with 1x1, 2x1 or 2x2 architecture. The switch offers very small size, ease of integration and the established solid state reliability of MEMS components. The plastic package is one of the smallest in the industry. It is optimized for low cost production while maintaining highest reliability comparable to a solid state device. The component is designed to exceed Telcordia 1221 quality standards.

### Features

- 23 x 10 x 6 mm size
- Low Cost
- TTL or CMOS logic
- latching or non-latching
- 2x2, 2x1, 1x1 variants
- single or multimode

### Applications

- Protection Switching
- Reconfiguration
- Optical Subsystems
- Array integration

### Description

The Mems-Switches are composed of an optical subsystem and an electrical driver interface. The optical switching function is realized by a silicon MEMS chip, on which a mirror can be moved in and out of the optical path by electrostatic actuation. In the latching MI-L variants a bistable suspension mechanism keeps the last selected state in power off. In the non-latching MI-N variants the switch returns into the bar state when electrical power is removed.

To operate the switch 5V and 0V are applied on pins 1 and 2, which are used by the DC-DC converter of the internal driver to supply a high voltage for the actuator control. CMOS or TTL logic levels on pins 3-4 control the high voltage on the electrostatic actuator.

To set the switch state in the latching variant, pin 3 respectively pin 4 are set to logic high (5V) for 10 ms and the corresponding switch state is selected. At rest pins 3 and 4 should be pulled to 0 V and must not be floating.

In the non-latching variant only pin 3 is used to set the state of the switch. To set the cross state pin 3 must be at logic high. When pin 3 goes to logic low, or at power off, the switch returns into the bar state. Technology by Sercalo.

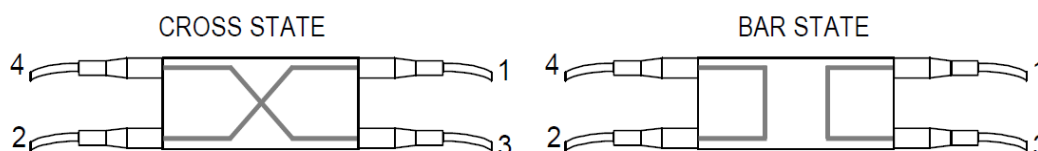

## 1x1, 1x2, 2x2, miniaturized (MI Series)

### Technical Specifications (for single mode fibres <sup>1</sup>)

	Unit	Min	Typ	Max
<b>Optical Switch</b>				
Wavelength Range	nm	1240		1640
Insertion Loss <sup>2</sup>	dB		0,4	0,9
Crosstalk	dB		75	60
Polarisation Dependent Loss	dB		0,03	0,07
Repeatability <sup>3</sup>	dB			0,002
Switching Time	ms		0,5	1
Durability	cycles		10 <sup>9</sup>	
<b>Integrated Driver</b>				
Supply Voltage Vcc (pin 1)	V	4,75	5	5,25
Current Consumption Icc (pin 1)	mA		1	10
Logic Level Low (pins 3, 4)	V			0,3
Logic Level High (pins 3, 4)	V	3		
Selection Pulse Width	ms	2	10	
<b>Package</b>				
Operation Temperature	°C	0		70
Storage Temperature	°C	-40		85
Size (L x W x H)	mm		23,2 x 10,1 x 5,9	

<sup>1</sup> for multimode: range: 600 – 1700 nm; IL @ 1300 nm: 1.2 dB max; CT max: 40 dB; RL max: 35 dB; Switching time: 5 ms.

<sup>2</sup> value @ 25 °C, without connectors

<sup>3</sup> for constant temperature and polarisation

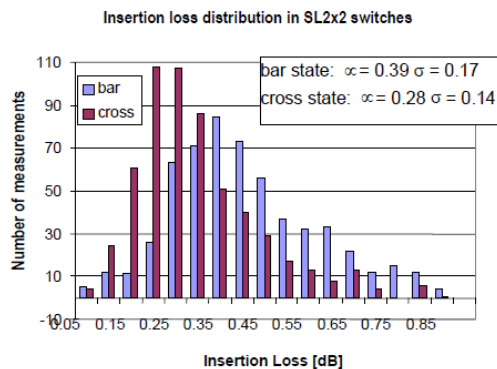

Figure 1: Insertion loss distribution

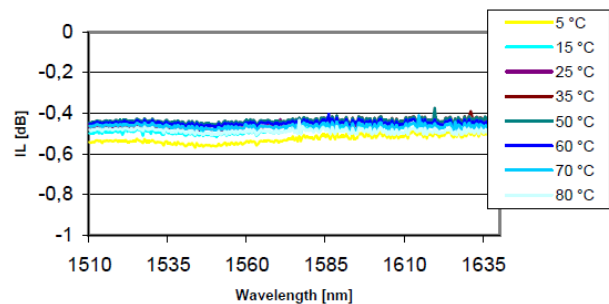

Figure 2: spectral response over temperature

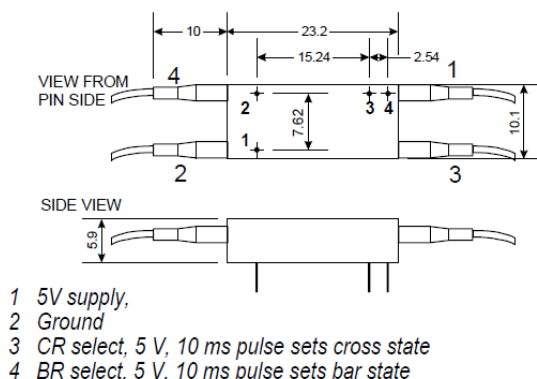

Figure 3: Pin layout MI-LT2x2 latching

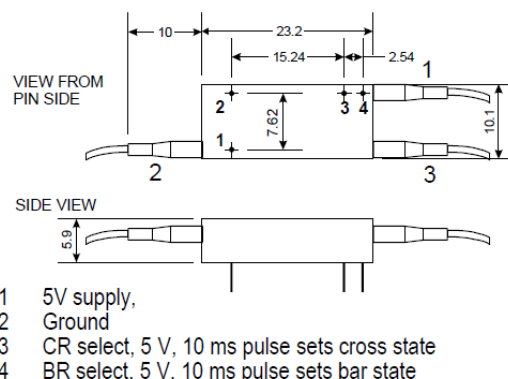

Figure 4: Pin layout MI-LT2x1 latching

# MEMS-SWITCH Cubes

## 1x1, 1x2, 2x2, miniaturized (MI Series)

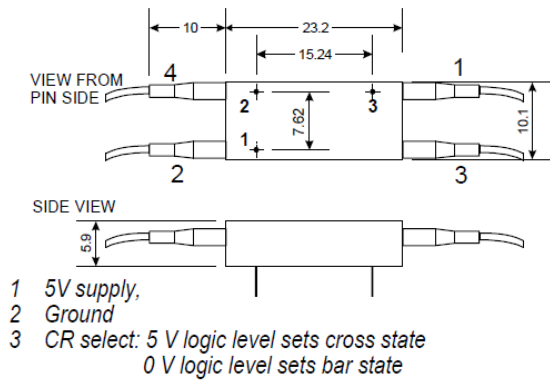

Figure 5: Pin layout MI-NT 2x2 non-latching

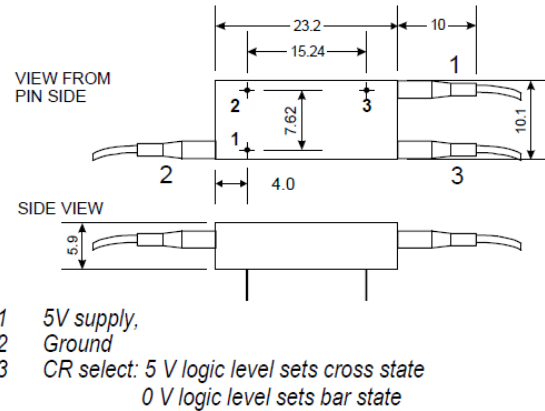

Figure 6: Pin layout MI\_NT 2x1 non-latching

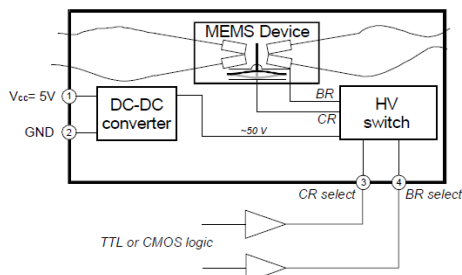
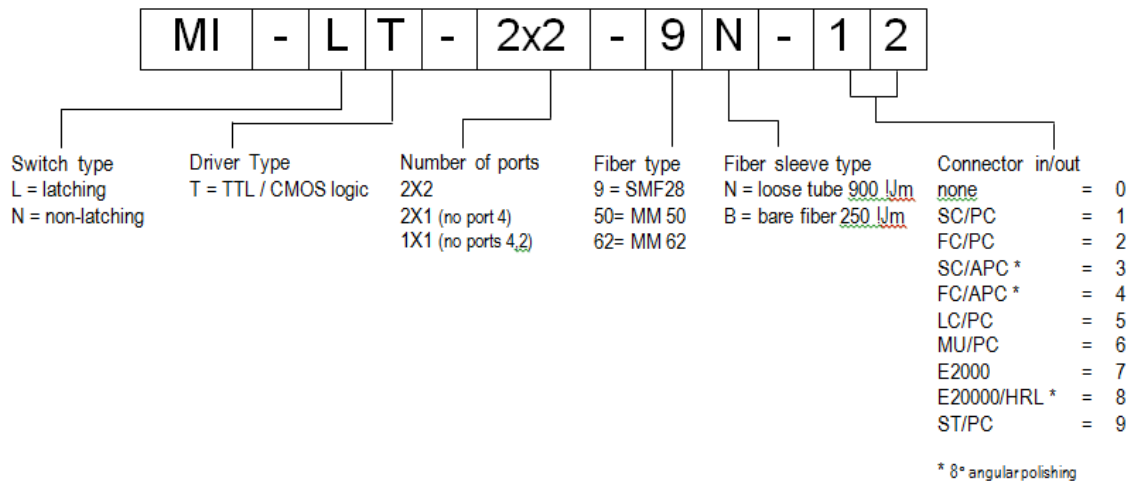

Figure 7: Electrical Schematic Diagram

## Ordering Information



HUBER+SUHNER Cube Optics AG  
Eindhoven-Allee 3  
55129 Mainz, Germany

+49-6131-4995-100  
sales.cubo@hubersuhner.com

www.hubersuhner.com  
www.cubeoptics.com