

17. Angkor Wat, Consciousness, and Universal Constants

by

Jeffrey S. Keen

BSc Hons ARCS MInstP CPhys

www.jeffreykeen.co.uk

Abstract

A study of the dowsable fields at the centre of Angkor Wat in Cambodia, (resulting from the analysis of scientific measurements that are independently reproducible), surprisingly results in the discovery of universal constants and precise relationships, that not only reinforces the validity of the dowsing research techniques being adopted, but also furthers the quest in understanding consciousness and the structure of the universe.

Angkor Wat - Introduction

Angkor Wat, in Cambodia, is part of a complex of constructions comprising numerous temples, with extensive irrigation canals, and lakes. The 'site' is about 40 miles wide and most of the temples are vast. The complex was built between 800AD – 1,300 AD, mainly in sand stone. Appropriate adjectives include Enormous, Impressive, Imposing, and Awesome. Unfortunately, centuries of neglect has resulted in nature taking over, with the majority of the site being over-run by the jungle, so that the trees merge with masonry. Fig 1 is an example of this, where the trees seem to be living off the displaced masonry giving a very eerie feeling.

The Jungle



Figure 1

Figure 2 represents only a small part of the overall complex, and gives the layout of some of the temples. The 2-mile scale at the bottom left gives an indication of the vast sizes involved. Angkor Wat, the main temple, and the subject of this article, is located at the bottom centre.



Figure 2

Dawn



Figure 3

Figure 3, is a photograph of the main entrance taken by the author at a 6 am sunrise whilst facing east, and illustrates the east-west orientation of the temple. Unlike most of the rest of the site, as Angkor Wat has been a continuously active Buddhist temple, the monks have kept the jungle out, and maintained the local site and buildings in an excellent state of preservation.

Dusk



Figure 4

Figure 4 is the same elevation at sun set, with the photographer again facing east in a similar location. The photograph was taken at about 6 pm, so it took the author about 12 hours to walk around just this one temple. This gives an indication of the vastness.

Figure 5 is a plan of the main temple, Angkor Wat, – the subject of this paper. As is apparent, the building is rectangular with an east - west main axis, and is surrounded by a large rectangular moat. The scale at the bottom left shows that the distance is about 1 mile from the main entrance on the left of Figure 5, to the east of the exit on the right of the moat. Along the east-west centre-line, there is a dowsable linear field along the whole of its length (over 1 mile long), together with a similar central north - south dowsable line. As we will see, the “earth energies” are particularly interesting where these two lines meet at the centre.

Of relevant general interest it is important to consider the local culture, and its connection to “earth energies”. Because of Cambodia’s geographical location it is influenced by both Indian and Chinese cultures. Angkor Wat has a strong Indian influence. Its builders wished to create an “open” design to encourage earth energies, which was the philosophy adopted in Indian architecture. Hence, there are many long dowsable lines, some greater than 1 mile. This contrasts to Chinese “closed”

architecture, where, for example, large thresholds are built at every internal and external door entrance, to prevent earth energies from leaving or entering each room or building. Anecdotal reasons are given that this Chinese philosophy keeps assets and money from escaping!

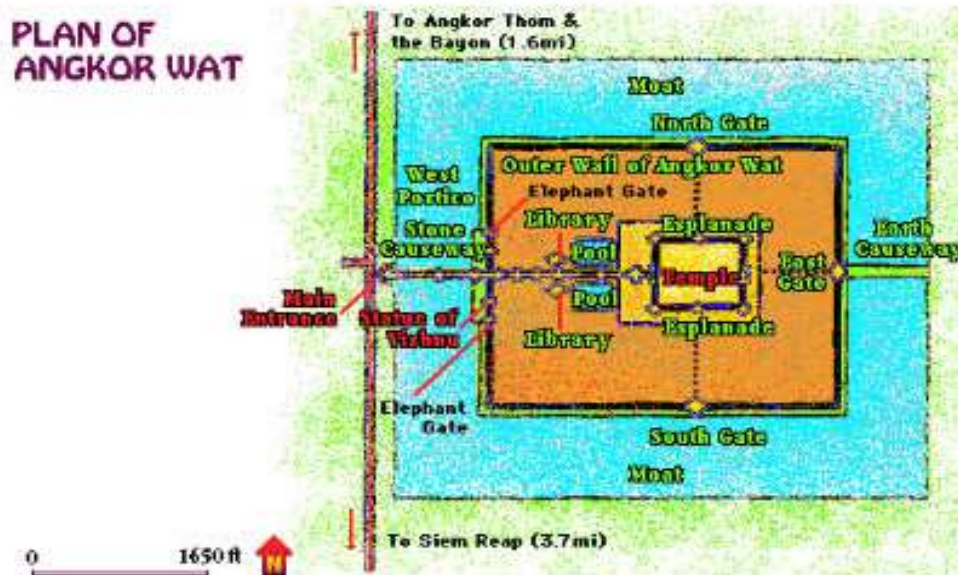

Figure 5

It is apparent that the builders felt and understood these earth energy fields. This view was reinforced by one of the local guides, who volunteered the information that his family had lived in the area for over 500 years, and that feeling these fields was normal. This is probably identical to European Stone Age man, who built their numerous megalithic structures that produced similar fields.

As mentioned above, the point at the centre of the temple has very strong and easily noticeable fields. Many people standing at this point are aware of strong sensations. Rods or pendulums are not required to feel them! This is just one of many dowsable fields, which we will now explore further.

The original builders of Angkor Wat must have known what dowsable fields they had created, and inserted this small rectangular marker tile at this centre point, where the east – west, and north – south lines mentioned earlier crossed. Figure 6 is a photograph of this centre marker. It may be significant that the author took about 200 photos of Angkor Wat, all of which were crisp. This photograph is blurred. Either there was camera shake from the effects of the field, or the fields were interfering with the digital camera. However, as will be shown, this is beneficial in proving the power of the technique adopted. As often in life, a negative can be turned in to a positive.

Photographs produce identical sensations, and can produce the same results, as dowsing on site. (see Reference 1 page 236). Orientation of the photograph makes no difference, nor does the fact that the photograph is blurred. In fact, this reinforces the power of this technique of dowsing photographs; once again demonstrating that a low

bit density of information is sufficient for success. As we will see, what we are utilising is a method of connecting the intent of the mind to the relevant part of the Information Field that is holding information regarding Angkor Wat.

The Centre Marker Stone



Figure 6

Possibly the reason for the fields feeling so powerful, is that six interwoven dowsable fields are present at this centre point, each with very different characteristics. This can be confirmed by dowsing Figure 6, which gives identical results, on a one-to one scale, as if the dowser was on-site. After asking “permission”, the intent is for the mind to go back in time when the photograph was taken (about 2pm 8th February 2005), and to transpose the location of the mind of the observer to the centre of Angkor Wat. The properties of each of these six fields are now discussed in turn.

1. Four lines N-S, E-W

The first of these 6 interwoven dowsable fields comprises the previously mentioned linear fields in a north - south, and east – west direction. These are Type 1 fields, which are usually associated with physical objects. In dowsing there are 4 types of fields, each with very different properties (see Reference 1 page 219). As we will see, the 6 fields at Angkor Wat comprise 3 out of these 4 types. As illustrated in Fig 7, there is an outward perceived flow from the centre. The length of these lines is about 250m, with a height of about 50 mm and a width of about 120 mm.

Four Lines N-S, E-W (Type 1)

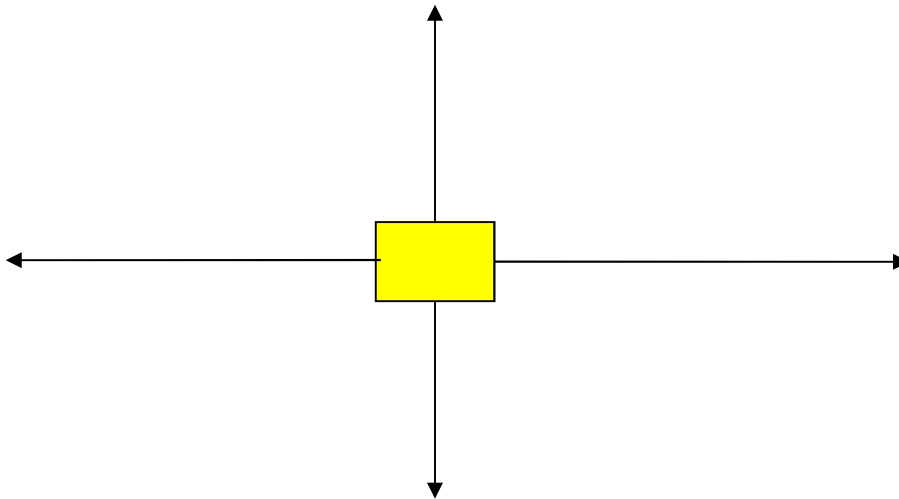

Figure 7

2. Four diagonal lines

The second field, perceived to be emanating from the corners of the rectangular centre tile are four diagonal lines, which also have an outward perceived flow, and are depicted in Figure 8. Unlike the previous lines, these are Type 4 fields, which are often associated with spiritual, prayer or mind generated actions (e.g. religious scrolls, church altars, worshiped Buddha's). (see Reference 1 page 229). These lines are also about 250m long, but have a height of about 10 mm. and a width of about 10 mm.

Four Diagonal Lines (Type 4)

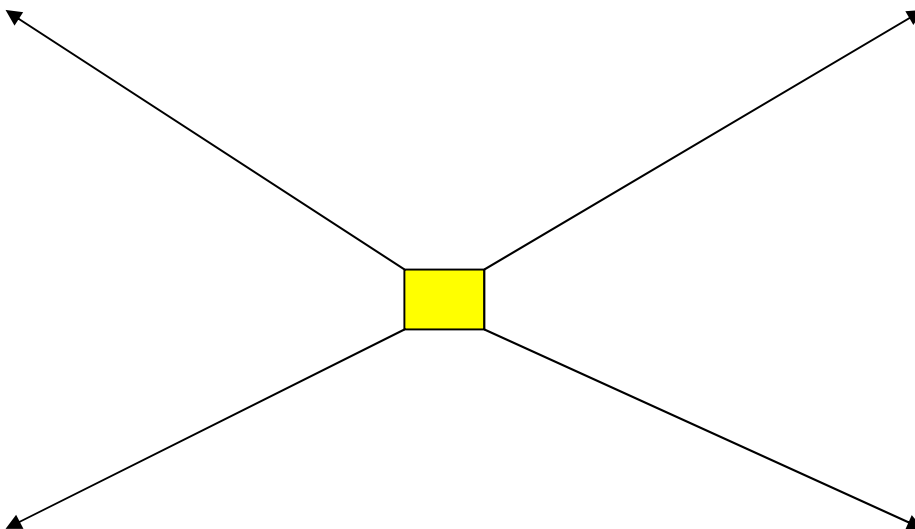

Figure 8

3. Conical Spiral - A

The third field, where the Type 1 lines in figure 7 intersect, appears as, a downward flowing anti-clockwise spiral as shown in Figure 9, which is a cross-sectional elevation through the main vertical axis. This is associated with the Type 1 lines. Detecting this spiral is facilitated if intent is focussed by approaching the centre whilst walking along any of the Type 1 lines. The spiral has an outer boundary of an inverted cone, with its apex at the centre of the marker, where the Type 1 lines intersect. This cone has a 19.5° half-angle, which is a very significant finding that will be discussed later. The cone is about 7 metres high with a 5 metres diameter base. The spiral is a Type 3 field. (see Reference 1 page 226).

Type 3 Conical Spiral (associated with Type 1 lines)

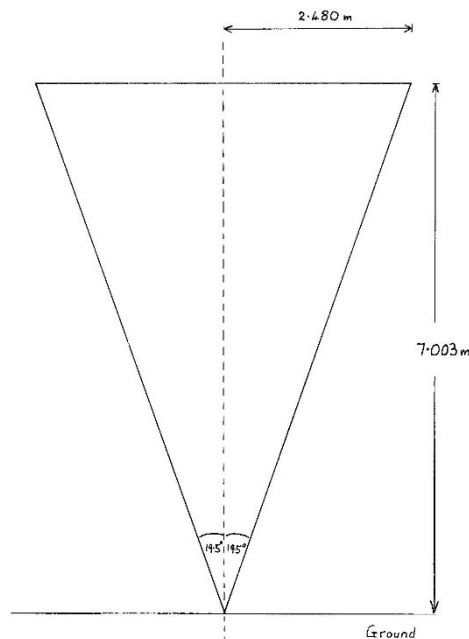

Figure 9

How does one obtain the above measurements? The angle of the cone is easily measured by dowsing the conical envelope with a pencil on a sheet of paper supported vertical on the axis of the spiral. One can then visualize the spiral from above, looking down. Using the power of dowsing, it is possible to project the 3 dimensional spiral onto a suitable flat surface, keeping the dimensions constant. As shown in Figure 10, as usual there are 3.5 turns. It is then possible to measure the separation distances between turns, and the diameter of the 2-D spiral on the ground. Trigonometry can then be used to derive the height.

Plan of the Anti-clockwise Spiral

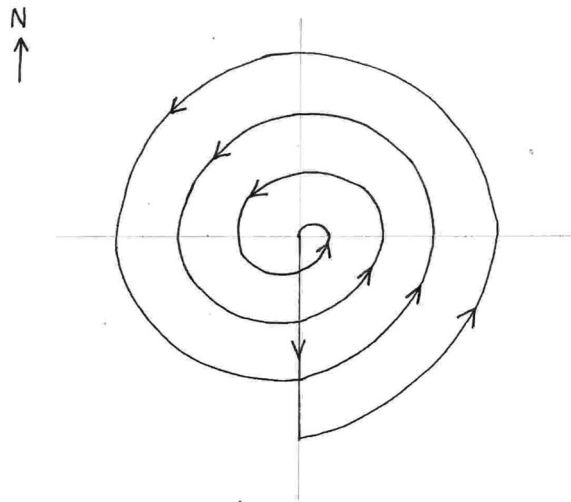

Figure 10

If we are being pedantic, this is not really a spiral, but more accurately a 3 – Dimensional, 3.5 turns, Conical Helix. The flow is downwards, with a vertical return, as shown in Figure 11.

Side Elevation View of an Anti-clockwise Spiral

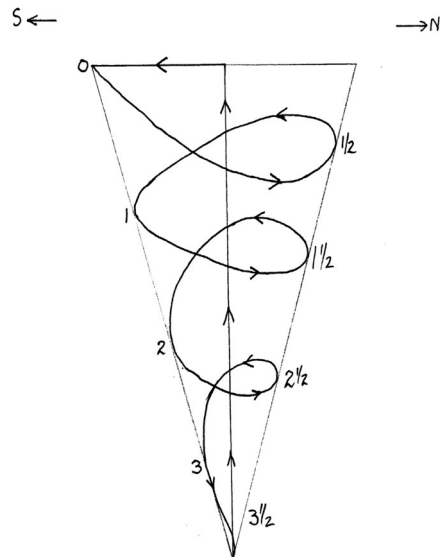

Figure 11

4. Conical Spiral - B

Figure 12 illustrates an upward flowing clockwise spiral, which is associated with the Type 4 lines discussed in section 2 above. To facilitate detection, intent can be focussed by approaching the centre marker along any of the Type 4 lines. Again, the envelope of the spiral is an inverted cone, which is concentric with the previous spiral, also having its apex at the centre of the rectangular marker where the Type 4 lines intersect. It too is a Type 3 spiral field. Significantly, there is an 11.5° half-angle, which will be discussed later. The cone is 5.775 metres in height, with a 2.350 metres base diameter. This spiral is smaller than the previous one, and sits inside the previous one.

Type 3 Conical Spiral (associated with Type 4 lines)

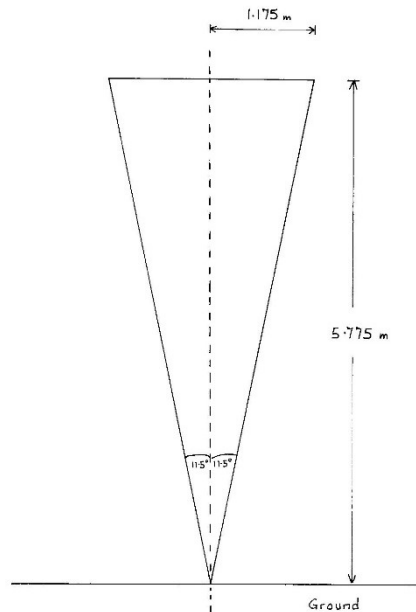

Figure 12

Turns of Spiral associated with Type 4 Lines

Turns n	Radius mm	(n+1)-n mm	(n+1)/n
0	0		
1	73	73	
2	154	81	2.11
3	225	71	1.46
4	357	132	1.59
5	552	195	1.55
6	875	323	1.59
7	1,192	317	1.36
Average Constant		170	1.61
Standard Deviation		111	0.26

Figure 13

Figure 13 is an analysis of the turns in this spiral. The separation distances between adjacent turns form a geometric series. (As is commonly found, a perturbation affects the first and last term of the series. This may form an interesting subject for future research).

5. Series of Spirals – A

Arithmetic Series of Spirals along Type 1 Lines

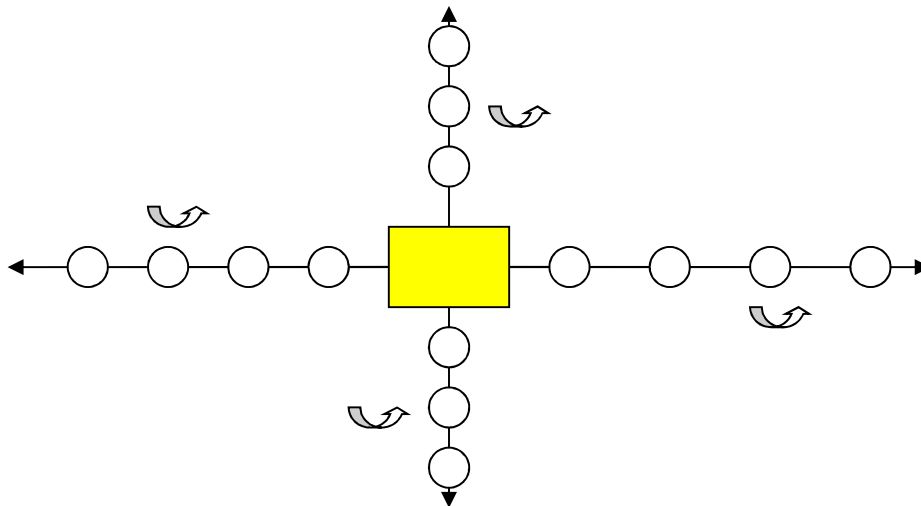

Figure 14

Separation distances of Spirals along Type 1 Lines

n	Separation mm	(n+1)-n mm	(n+1)/n
1	1,210		
2	2,675	1,465	2.21
3	4,385	1,710	1.64
4	6,020	1,635	1.37
5	7,530	1,510	1.25
6	9,140	1,610	1.21
7	10,800	1,660	1.18
8	12,610	1,810	1.17
Average Constant		1,629	1.43
Standard Deviation		117	0.38

Figure 15

As depicted in Figure 14, which is a plan of the pattern, there are a series of Type 3 spirals, which extend for about 250m along the entire length of each of the four Type 1 lines. These spirals all reflect the central spiral, with similar properties. Therefore, they are downward flowing anti-clockwise spirals with an inverted cone, all having the

same height, and having the same vertical cross-section as in Figure 9. It is the same pattern for all four Type 1 lines.

Figure 15 shows the separation distances between successive spirals. As is apparent, there is less of a preference for a geometric series, but a tendency for an arithmetic constant of approximately 1.6 metres. I.e. each spiral is approximately 1.6 metres from the previous spiral. The series of spirals have the same separation distances for all four Type 1 lines. This is an example of reflections, or self-replicating geometry. We will see later that this is a very important concept.

6. Series of Spirals - B

As illustrated in Figure 16, there exists a sixth field comprising a series of Type 3 spirals along the length of all four diagonal Type 4 lines. These spirals all reflect the central spiral associated with the Type 4 lines, each with similar properties. i.e. they are upward flowing clockwise spirals, with an inverted cone the apex of which touches the Type 4 line on the ground, with a vertical cross-section the same as Figure 9. As before, the spirals extend along the whole length of the line, which is about 250m. All four Type 4 lines produce the same separation distances between adjacent reflected spirals, which is summarised in Figure 17.

Geometric Series of Spirals along Type 4 Lines

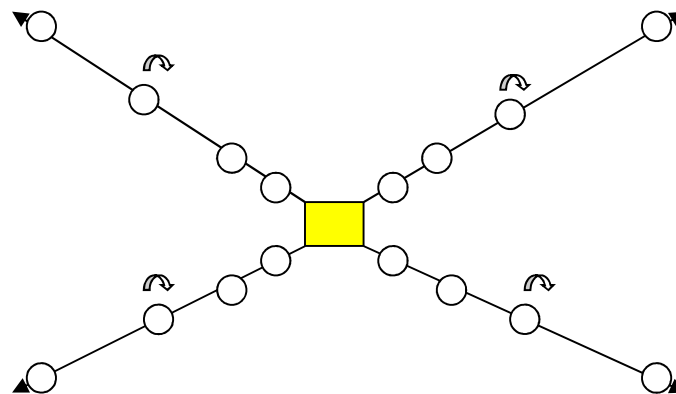

Figure 16

The measurements demonstrate that this series of spirals on the diagonal lines is different from the previous series of spirals. Unlike the spirals associated with the Type 1 lines, there is less of a preference for an arithmetic series, but a stronger tendency for a geometric constant of 1.281. i.e. adjacent spirals are approx 1.281 times the distance from the previous one. This is tantalising close to either $9/7$ which equals 1.2857 (the ratio of the number of aura reflections of Type 4 to Type 1 fields), or to $\sqrt{\phi}$ which equals 1.2720. Measurements that are more independent are obviously required to prove if one of these universal constants is indeed applicable, or if the result is merely a coincidence.

Separation distances of Spirals along Type 4 Lines

n	Separation m	(n+1)-n m	(n+1)/n
1	1.21		
2	2.28	1.07	1.89
3	3.02	0.74	1.32
4	3.96	0.95	1.31
5	5.85	1.89	1.48
6	7.14	1.29	1.22
7	8.36	1.22	1.17
8	9.63	1.26	1.15
9	10.81	1.18	1.12
10	12.42	1.62	1.15
11	14.27	1.85	1.15
12	16.71	2.44	1.17
13	20.61	3.90	1.23
14			
15			
Average Constant		1.62	1.281

Figure 17

Summary of Conclusions

Numerous conclusions can be drawn from the above observations. These are numbered for ease of reference.

1. Once again, there is confirmation of the power of using the technique of dowsing in the scientific study of consciousness, for establishing relationships, and in the search for universal constants.
2. The validity of dowsing relevant photographs is again well demonstrated. Even blurred photos, or ones with a low bit density, or black and white photographs, or digital photos with few pixels.
3. Spirals are very common in dowsing. They usually have a conical envelope and a vertical axis. The latter suggests that **gravity** is involved.
4. Although the configuration of dowsable fields found at Angkor Wat may be unique, scientific measurements show that the individual linear and spiral field components are very common, and are the same as can be found on most European ancient sites and substantial buildings.
5. The preference for arithmetic series in Type 1 fields (associated with physical bodies), and geometric series in Type 4 fields (associated with mind and vortex generated activities) is consistent with other reported general observations and laboratory experiments.
6. We have examples of self replicating geometry, repeating patterns, or reflections.

7. It cannot be co-incidence that key angles have been found, which as we will see have a more general universal significance. An introduction to the geometry of these angles is shown in Figures 18.

Universal Constants

Up to now, we have talked about Angkor Wat. It is about time we discussed the other subjects in the title of this article – consciousness, and universal constants. So let us start with the 19.5° half-angle. To a higher level of accuracy, this angle is 19.471° . Figure 18a shows how one may get this angle?

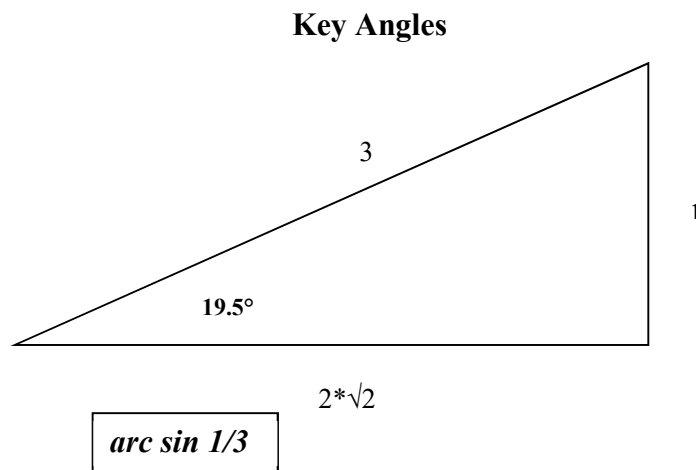

Figure 18a

Traditionally, if the reader prefers Geometry, then Pythagoras theorem applies to the angle 19.471° , which occurs in a basic right-angled triangle with sides:

$$1:3:2*\sqrt{2}.$$

Personally, the author cannot get too excited about $\sqrt{2}$, as this is an irrational number going to infinity and difficult to comprehend.

Alternatively, as we will discover, it is more useful if **Trigonometry** is preferred, as we are dealing with a real, small, and tangible number : 3. So, 19.471° is the angle that has a **sine** of $1/3$.

Let us now look at the next number, 11.5° . To a higher level of accuracy, this angle is 11.537° . How does one get this angle? Again, using Pythagoras theorem we have a right-angled triangle as in Figure 18b with sides:

$$1:5:2*\sqrt{2}*\sqrt{3}$$

However, we now have **two** irrational number to comprehend $\sqrt{2}$ and $\sqrt{3}$

But using **Trigonometry** we have a simple number: 5. So, 11.537° is the angle that has a **sine** of $1/5$.

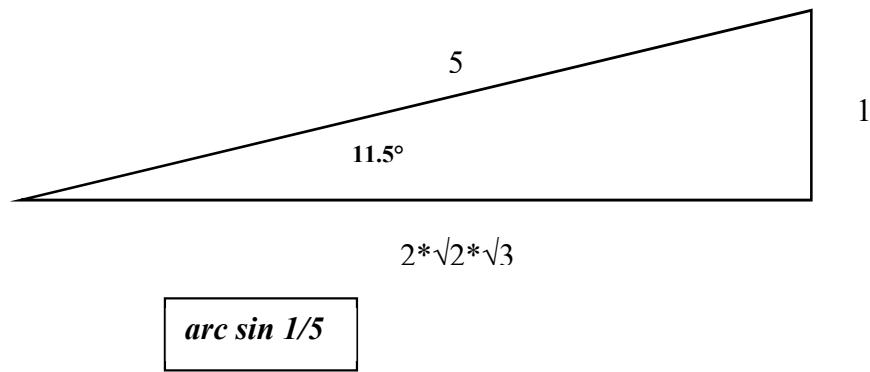

Figure 18b

In reality, there are more than 2 concentric conical spirals. One can dowse an ever decreasing set of smaller cones. The next angle is illustrated in Figure 18c, and has a sine of 1/7.

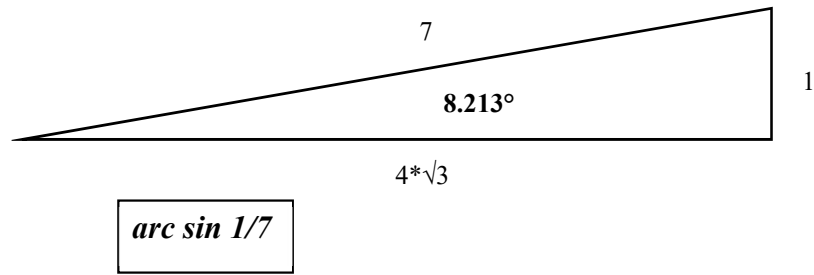

Figure 18c

There are 2 important points to remember here. There is a series of:

1. angles whose sine's are the reciprocal of the odd numbers 3, 5, 7, 9,.....
ie arc sine 1/3, 1/5, 1/7, 1/9, and so on.
2. cones, which are the third example in this article of reflections, or self-replicating, or fractal geometry.

More about both of these points later

Two other “universal angles” are:

$$54.735^\circ$$

$$35.264^\circ$$

These two angles are complementary as they add up to 90°. There is a relationship between these two angles and 19.471°, which is relevant to the wider scientific significance of these conclusions:

$$35.264^\circ = (90^\circ - 19.471^\circ)/2$$

$$54.735^\circ = (90^\circ + 19.471^\circ)/2$$

We now have four universal constants, 19.471°, 11.537°, 35.264°, and 54.735°. Even a cursory internet search of academic papers (eg using Google Scholar) gives numerous other examples where these angles occur. Diverse topics range from columnar vortices; cosmology; Ampere and dipole force laws and null-points; static and dynamic studies of polyhedral structures, vortices, and torroids; astronomical events on the surfaces of Jupiter and Saturn; flight dynamics; chemistry and molecular structures; fluid

dynamics, including bow waves and the Kelvin Wedge; climate studies; aging bone studies; cognitive behaviour; statistical analysis of the size of birds; quantum mechanics for spin $\frac{1}{2}$ particles in a magnetic field; etc.

The obvious conclusion is that dowsing is just as valid in broad scientific research, as any other discipline. We obtain the same universal constants.

Cause of Dowsable Fields

So what causes these observed dowsable fields at Angkor Wat? Often ancient sites are located over intersecting underground watercourses, which were the cause of spirals and other dowsable fields. These fields were perceived by the site's builders, as preferred locations for their constructions, which would become enhanced by the effects of these dowsable fields.

However, in this instance the reverse seems to apply. Although there is much water integral to the Angkor Wat complex, all the fields discussed in this paper were not present prior to the site's construction. A non-controversial reason, one of several that supports this statement, is that all the "energy lines" are straight. Natural "energy lines" meander. Additionally, dowsing the age of the spirals gives a date after the construction of Angkor Wat.

One thing is for sure, the builders of Angkor Wat would not have known the finer points of trigonometry and mathematical universal constants, nor did they set out to achieve the geometry and patterns discussed in this article. It is apparent though, that they knew, in common with numerous other civilisations in the ancient world, that certain buildings produce significant "sensations" and "energy lines" that could readily be felt by the populous. This would enhance the power and influence of the temples, rulers, and priests, over and above the impact of awesome monumental structures, without the dowsable fields.

So where do these dowsable fields come from? This research work supports the theory that these dowsable fields are a natural result of the interaction of the geometry of the architecture, and the physical presence of matter (such as sand-stone masonry and water lagoons) with a universal field. The latter concept has numerous names ranging from the Akashic Record from thousands of years ago, to the Zero Point Field, the Information Field, or more recently, the Cosmic Internet.

This paper therefore adds yet more evidence of the commonality between the structure of the universe, geometry in general and polyhedral and vortex structures in particular. Research also indicates that all of these concepts, link in with the latest findings in quantum theory, with universal connectivity, entanglement, and consciousness. This helps to explain local and remote dowsing, map dowsing, remote healing, telepathy, and other associated phenomena.

Holographic Universe

Let us drill down a bit deeper into the above concepts. General research by many people in different disciplines comes to the same conclusion that we live in an information orientated holographic Universe. The Information Field stores information similar to a

hologram. The most famous property of holograms is that any part of a hologram stores the entire image. A good demonstration illustrating that dowsing may be linked to holograms, is to slice off a small piece of the photograph of the centre marker. On dowsing the latter, one obtains exactly the same effect as the whole photograph, ie the same fields and measurements are obtained as in this article.

How does the Information Field form Conical Helices?

An obvious question to ask is how does the Information Field form conical helices? There are 2 considerations

1. Spirals
2. Cones

Let us look at each separately, but first we also need to consider a torus.

A Torus

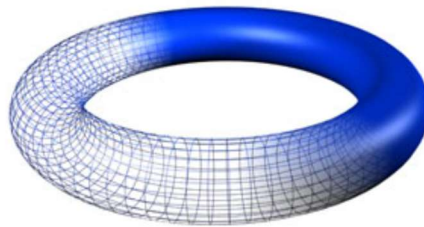

Figure 19

Figure 19 is a representation of a 3-D torus, or popularly known as a doughnut, or bagel shape. In the model about to be developed, let us assume that these infinitesimally small quantum tori are spinning like vortices to form the Information Field, analogous to a “quantum foam”.

A Torus can spin or rotate in 3 different ways:-

1. If, for example, it is flexible, or a fluid, or an energy field it can roll in and out on itself. Analogies of this could be smoke rings, vortices in a tornado, or water flowing down a plughole.
2. It can rotate about a vertical axis, so it appears to remain in the same place.
3. It can rotate about a horizontal axis like a paddle wheel.

Combining motions 1 and 2 above, and visualising a point on the surface, produces a circular spiral.

In order to illustrate how it is possible to produce a cone, let us consider a torus where the hole in the centre has the same diameter as the thickness of the torus. Figure 20 represents a cross-section through the centre of our special torus, where each component has a radius (a), and diameter ($2a$).

1 Torroid

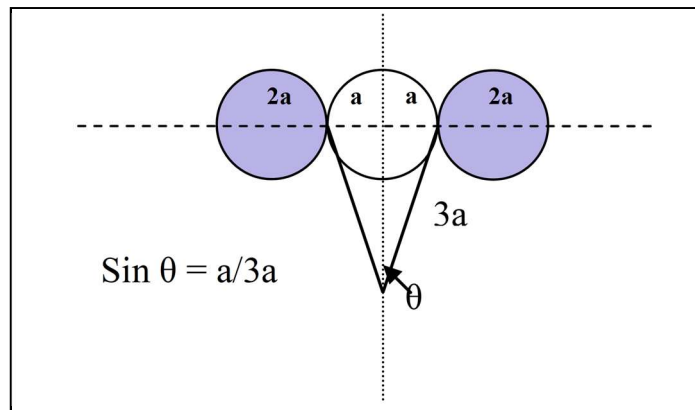

Figure 20

Consider a cone that

- has a slope length equal to the radius of the torus ($3a$)
- and just fits into the centre hole of the torus, so it has a base radius (a).

This cone has a half angle whose sine is $1/3$. This represents the first spiral of 19.5° .

2 Tori

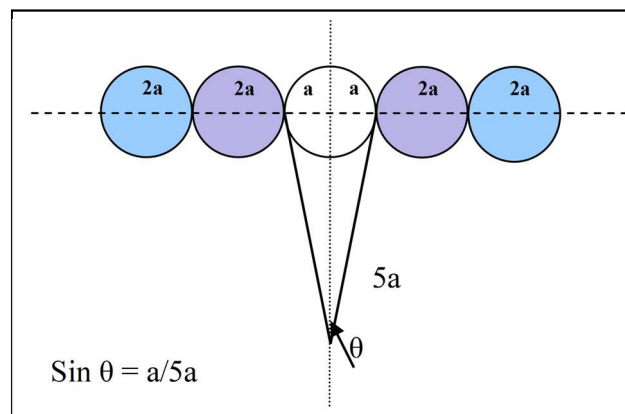

Figure 21

Let us now add another torus of the same thickness as the previous, but fits round the first torus. This is depicted in Figure 21. A cone that

- has a base equal to the diameter of the centre hole of the first torus, (i.e. it has a radius (a) as before.)
- and a slope length equal to the radius of the combined torus ($5a$).

This cone has a half angle whose sine is $1/5$, and represents the second spiral, of 11.5° .

Interestingly, if one torus is rotating in one direction the other rotates in the opposite direction. This may explain alternate spirals being clockwise and anti-clockwise.

3 Tori

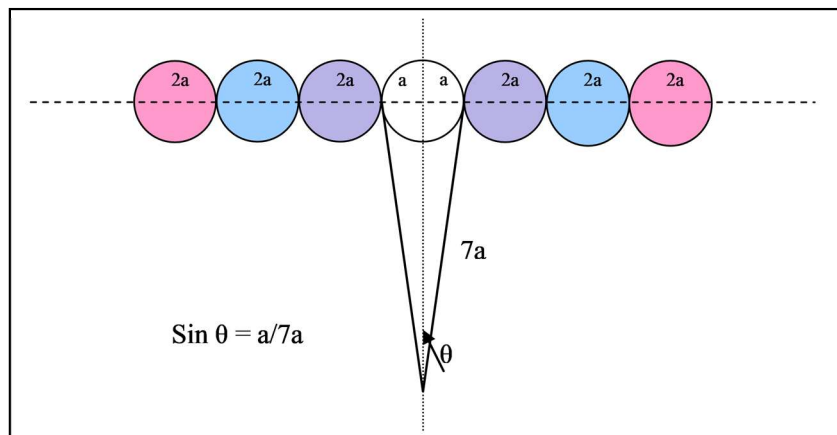

Figure 22

Let us introduce a third torus, that fits round the other 2, as illustrated in Figure 22. A cone that has a base equal to the centre hole of the original torus, and a slope length equal to the radius of the 3 combined tori, has a half angle whose sine is $1/7$. This represents the third spiral, of 8.2° .

As before, each torus is rotating in opposite directions, and as before, this could explain alternate spirals in the series being clockwise and anti-clockwise. This model of additional tori can obviously be extended to explain other cones in the series.

Although this is not a proof of the structure of the Information field, it may be a good analogy or hint that the Information Field comprises vortices and spinning tori. As gravity is involved, maybe part of the Information Field is appropriately aligned so that the vortices produce cones with vertical axes.

The next obvious question is why should cones at the quantum level appear 7 metres tall in our minds? The mechanism for this could be yet another example of fractal geometry, whereby phenomena at the micro and quantum level become reproduced at the macro level.

String Theory has long had problems in providing tangible scientific measurements, and explaining the structure of the universe. Instead of vibrating strings, it may well prove fruitful to further develop the “Spinning Bagel Theory”

In conclusion, there are two sobering thoughts.

1. It is not Angkor Wat that has produced these findings. The same conclusions could be derived from most dowsable sites, anywhere in the world.
2. With just a pair of bent coat hangers, a blurred photo of an old stone, and dowsing, we are working at the cutting edge of fundamental scientific research.

We are indeed living in exciting times.

Further Research

Set out below are suggested areas for further research.

1. There is the general motivation to hunt for other universal constants using the proven technique of dowsing to further the study of consciousness.
2. What causes the differences between the four field types, and what is their origin?
3. What is the nature of the linear and spiral fields that have a perceived “flow”?
4. Where does all the “flow” outwards from the centre come from and go to?
5. Is energy involved, or is a potential difference being detected?
6. When measuring the turns of spirals or their separation distances, what causes the perturbations to a simple mathematical progression?
7. What is the minimum number of pixels in a dowsable photograph?
8. What is the connection between vortices of tori, and the holographic storage of information in the Information Field?
9. Is mass required for the Information Field to store information?

As always, there are more queries than answers!

Acknowledgements

Acknowledgements are due to the Dowsing Research Group members who reviewed some of the observations and conclusions discussed in this article. In particular, Bob Sephton initially assisted the author in separating out the superimposed fields, and Jim Lyons, assisted in placing the findings of the key angles in the wider scientific context.

Bibliography

- 1 Jeffrey Keen; *Consciousness, Intent, and the Structure of the Universe*; Trafford; 2005; 1-4120-4512-6; www.trafford.com/robots/04-2320.html
- 2 Jude Curran; *The Wave*; O-Books; 2005; 1-905047-33-9
- 3 Dean Radin; *Entangled Minds*; Paraview; 2006; 1-4165-1677-8
- 4 Ervin Laszlo; *Science and the Akashic Field*; Inner Traditions; 2004; 1-59477-042-5

© 2006 by Jeffrey S Keen

All rights reserved. No part of this article may be reproduced, stored in a retrieval system, or transmitted or translated in machine language in any form or by any means, electronic, mechanical, photocopying, recording, or otherwise, without the prior written permission of the author.